

(No Model.)

2 Sheets—Sheet 1.

C. C. ONSGORD. BRAKE.

No. 528,019.

Patented Oct. 23, 1894.

FIG. 1.

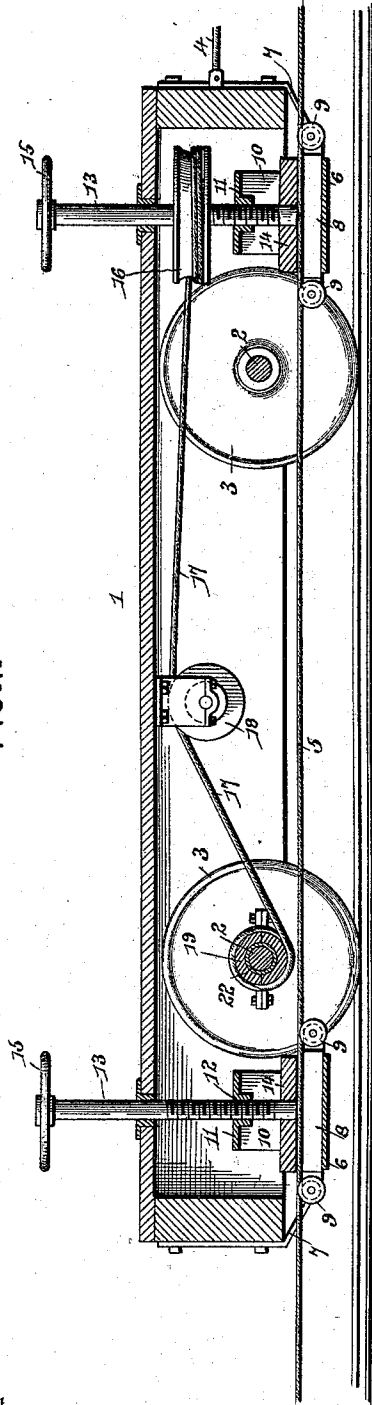
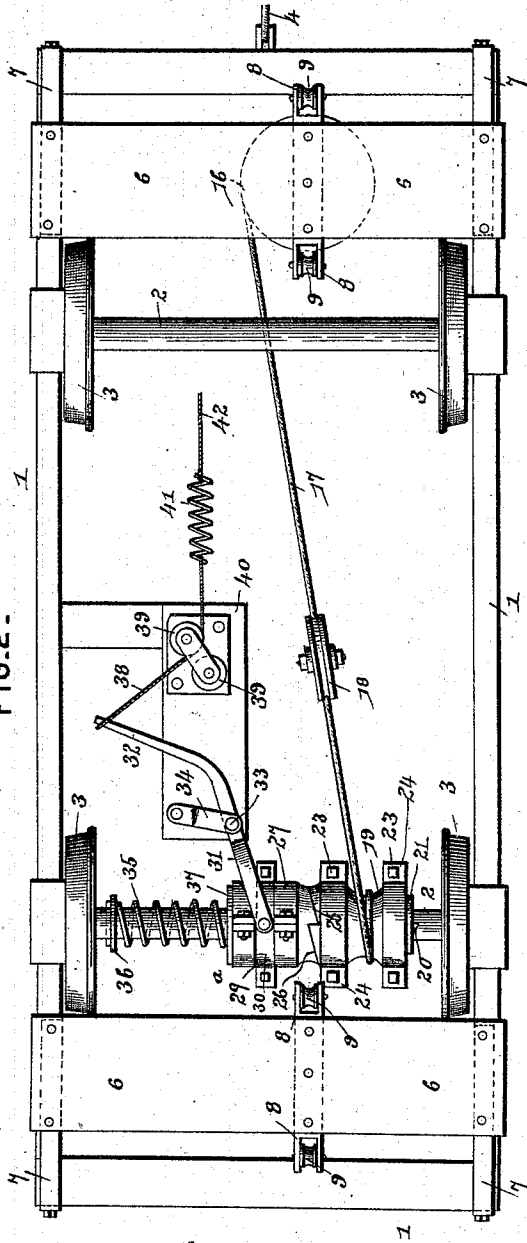

FIG. 2.



Inventor

Christen C. Onsgord

By *his* Attorneys.

Casey & Co.

Witnesses.

Jas. K. McArthur

J. B. Owens

(No Model.)

2 Sheets—Sheet 2.

C. C. ONSGORD. BRAKE.

No. 528,019.

Patented Oct. 23, 1894.

FIG. 3.

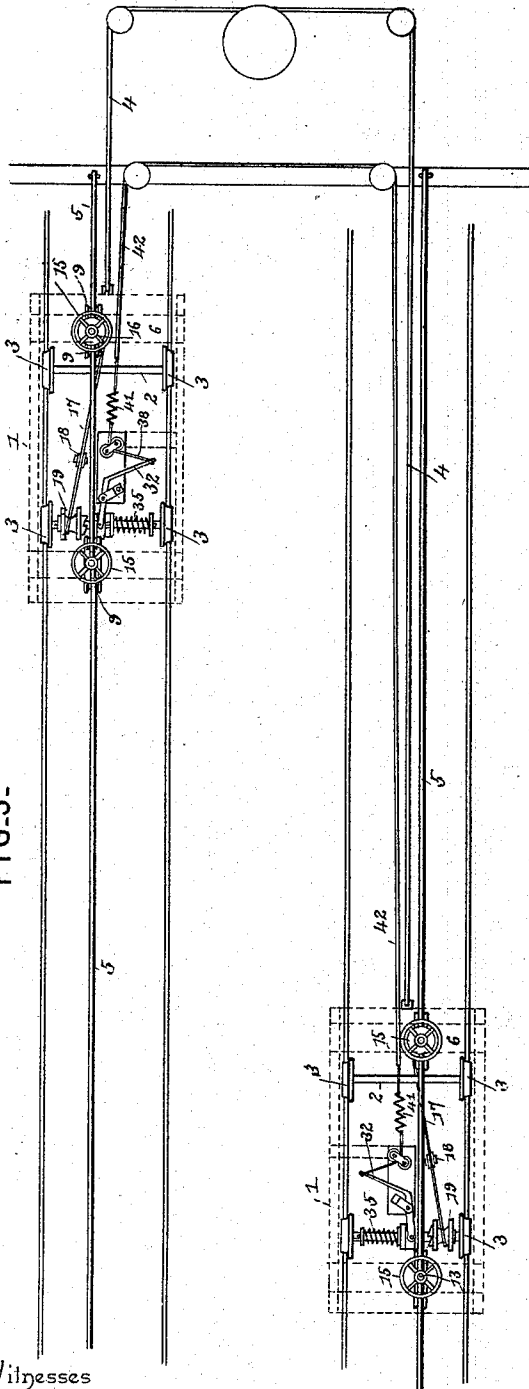

FIG. 5.

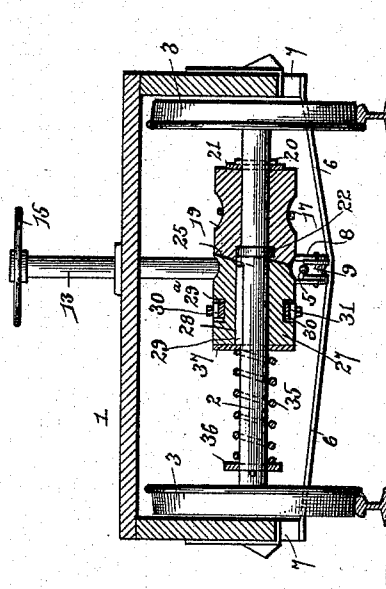
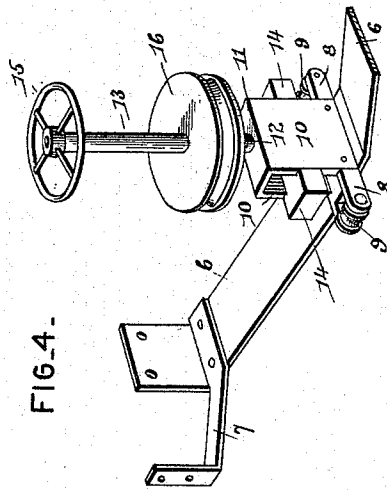

FIG. 4.



Inventor

Christen C. Onsgord

By *his* Attorneys.

C. Snow & Co

Witnesses

Jas. H. McLaughlin
J. P. Remond

UNITED STATES PATENT OFFICE.

CHRISTEN C. ONSGORD, OF WEST DULUTH, MINNESOTA.

BRAKE.

SPECIFICATION forming part of Letters Patent No. 528,019, dated October 23, 1894.

Application filed May 1, 1894. Serial No. 509,680. (No model.)

To all whom it may concern:

Be it known that I, CHRISTEN C. ONSGORD, a citizen of the United States, residing at West Duluth, in the county of St. Louis and State of Minnesota, have invented a new and useful Brake, of which the following is a specification.

My invention relates to an improvement in that class of railway brakes which are designed for use on inclined railway cars; and the object sought to be attained is to provide an appliance whereby the brake will be automatically applied as soon as the car or cars become in danger of "racing." This end I attain by providing brake mechanism which has a normal tendency to operate and which is held inactive by a cable arranged to be broken when the accident to the driving cable takes place.

In the accompanying drawings: Figure 1 represents a longitudinal section of a car supplied with my improvements; Fig. 2, a bottom plan; Fig. 3, a diagrammatical view illustrating the arrangement of cables and their relation to the brake; Fig. 4, a detail perspective of the rope-grip for the safety-rope; Fig. 5, a cross-section of the machine taken longitudinally with one of the axles.

The reference numeral 1 indicates the car, which may be of any preferred construction, and which is provided with the two revolving axles 2, to which the wheels 3 are rigidly secured.

4 indicates the drive-cable, which is secured to the end of the car and by which the car is driven. This cable 4 has its remaining end connected to a second car, as shown in Fig. 3, so that as the first car ascends the incline the second car will descend, and vice versa.

The cable 4 is connected at a point between its ends to a mechanism for applying power thereto, as will be understood and as indicated in Fig. 3.

5 indicates the safety-cable which is one for each track and which is securely fastened to some stationary object at each end. The purpose of this cable 5 is to furnish a means for arresting the "racing" of the cars when the cable 4 breaks, as such cable often does.

Secured to the under side of the car 1, and

at each end thereof, are the frames 6, which project downwardly and thence horizontally and are braced by the rods 7. Rigidly secured to the upper side of the horizontal portion of the frames 6, and at about the middle thereof, are the cable-grips 8, which consist of a base-plate having the rollers 9 at each end and the side plates 10 arising one from each side. The side-plates 10 are formed with an arch 11 at their upper ends, and these arches are formed with internally-threaded openings 12, through which the threaded shafts 13 extend.

The shafts 13 have their lower ends revolvably connected to the shoes 14, which are arranged between the side-plates 10, and movable vertically therein toward and from the base-plate. Over the base-plate and under the shoe 14, the rope 5 is adapted to pass, and when the shoes are raised the car will be allowed free movement on the cable. The shafts 13 extend vertically from the grips 8 and through the flooring of the car, and have their upper ends provided with the operating-wheels 15, by which they may be turned and the shoes made to engage the cable 5. This will result in a connection between the two parts and a consequent stopping of the car.

Rigidly secured to one of the shafts 13, at a point below the flooring of the car, is the pulley 16, which is grooved on its periphery and adapted for the passage of the rope 17. The rope 17 is wrapped around the pulley 16 twice, and is then passed over the idler 18 and around the drum 19, which is loosely mounted on one of the axles 2. The drum 19 is held incapable of lateral movement by means of the pin 20, and washer 21, and by means of the collar 22, formed integral with or rigidly secured to the axle. This drum is formed, by preference, of two sections bolted to each other by bolts 23, passing through the ears 24. The right-hand end of the drum 19 is formed with the ratchet face 25, which is adapted to match with the corresponding face 26 on the sliding clutch-section 27. The clutch 27 is also formed of two sections bolted together and has the longitudinal groove 28 formed on its interior. This groove is adapted to receive the longitudinal rib 29 of the axle upon which the clutch is mounted,

whereby the clutch is arranged so as to be capable of independent longitudinal movement on the shaft and incapable of independent rotary movement. Formed on the clutch 5 27 is the annular groove 29, which is adapted for the reception of the collar 30. The collar 30 is loosely mounted in place and is formed of two sections, as are the companion devices.

Rigidly secured to the collar 30 are the 10 forked arms 31 of the lever 32, which lever is fulcrumed to the pin 33, fixed, in turn, to the plate 34. The plate 34 is rigidly secured to the framework of the car, as shown in the drawings. Mounted on the axle having the 15 above-described clutch mechanism is the spiral spring 35, which is held against the clutch 27 by means of the pin and collar 36, and has a collar 37 at its remaining end. This latter collar is pressed against the clutch 20 27, thereby giving it a tendency toward the drum 19.

The lever 32 has its free end bent laterally and connected to the cable 38, which passes between the pulleys 39, of the beam 25 40, whereby upon pulling on the cable 38 the lever will be swung on its fulcrum so as to move the clutch 27 away from the drum 19, and thus keep the two disengaged. Upon releasing the pressure on the cable 38, the 30 clutch 27 will be allowed to engage the drum, thereby causing the drum to revolve with the axle. This will revolve the pulley of the shaft 13, and cause it to press the shoe 14 into engagement with the rope 5, for a purpose that will be more fully described hereinafter. Connected to the cable 38 is the re- 35 tractile spiral spring 41, and this has its remaining end connected to the small cable 42, which proceeds along parallel with the cable 40 4, and is connected at its remaining end to mechanism similar to that just described and arranged on the car to which the remaining end of the cable 4 is connected.

By reference to the drawings, particularly 45 Fig. 3, the operation of my invention may be traced as follows: Supposing that the cars are being propelled by the power in connection with the rope 4, and that the rope 4 breaks. This would release them and make 50 it possible for them to "race" down the incline. As soon as such movement is begun, however, the cable 42 will be subjected to undue strain, which will result in its fracture, and a consequent release of the lever 32, allowing the clutch 27 and drum 19 to engage. 55 This will cause the rope 17 to operate, and in so doing revolve the shaft 13, to which it is connected. As the shaft 13 revolves, the shoe 14 will be forced into engagement with the safety-rope 5, thereby stopping further 60 movement of the car. The shaft 13, which is not connected to the rope 17, may be used as a hand-brake, if so desired, or if necessary may be provided with a pulley and rope as 65 its companion, so that the brake will operate doubly.

By means of the idler 18 the rope 17 will

be kept taut, and consequently in engagement. The purpose of the spring 41 is to give the cable 42 a limited amount of elasticity, so that the usual jars and jerks attending the movement of the cars will not break it. 70

While I have described my invention as applied to a double-track system, it will be 75 seen that its use is not so limited, since it could be used with equal facility on a single track, by connecting the cable 42 to a drum winding in unison with the winding mechanism of the cable 4. 80

Having described my invention, what I claim is—

1. The combination of a car, a propelling cable connected thereto, a stationary cable by which the car passes, a grip on the car and 85 operating in connection with the stationary cable, said grip being connected with a drum mounted on the car-axle, a clutch for fixing the drum to the axle and having a normal tendency toward the drum, and a third cable 90 connected to the clutch and operating to hold it out of engagement with the drum, the last-named cable being adapted, upon the breaking of the propelling cable, to break and release the clutch, thereby operating the grip 95 to bind with the stationary cable and stop the car, substantially as described.

2. The combination of a car, a propelling cable connected thereto, a grip on the car, a stationary cable passing through the grip, a 100 drum mounted loosely on one of the car-axes, a clutch fixed to the axle and having a normal tendency to engage the drum, a bent lever connected to the clutch, a cable connected to the lever and adapted to hold the clutch 105 from engagement with the drum, and a belt connecting the drum and grip whereby when the last-named cable is broken, upon the breaking of the propelling cable, the clutch will engage the drum and cause the grip to 110 bind with the stationary rope and thus stop the car, substantially as described.

3. The combination of two cars adapted to move simultaneously in different directions on an inclined plane, a propelling rope connected to each at its ends, a grip on each car, a stationary rope for each grip, means for applying the grip, said means having a normal tendency to operate, and a third cable connected to each car and operating to hold said 120 means inactive, whereby upon the breaking of the propelling cable the third cable will break also and allow the grip to bind with the stationary cable, thereby stopping the car, substantially as described. 125

4. The combination of a car, a frame depending therefrom, a threaded shaft arranged above the frame, a grip-shoe on the shaft and adapted to bind against the frame, a stationary rope passing between the frame and the 130 shoe, a drum mounted loosely on the car-axle, a belt passing over the drum and shaft, whereby the shaft is operated, a clutch fixed to the shaft and having a normal tendency to en-

gage the drum, a cable connected to the clutch and operating to hold the same from engagement with the drum, a propelling cable connected to the car, whereby upon the breaking of the propelling cable the clutch-cable will break and allow the drum to operate the shoe, thus gripping the stationary cable and stopping the car, substantially as described.

In testimony that I claim the foregoing as my own I have hereto affixed my signature in the presence of two witnesses.

CHRISTEN C. ONSGORD.

Witnesses:

- HARVEY P. SMITH,
S. E. PETERSON.