

A. J. GLAS.
APPARATUS FOR DECORTICATING, SEPARATING, AND DRYING GRAIN.
No. 107,480. Patented Sept. 20, 1870.

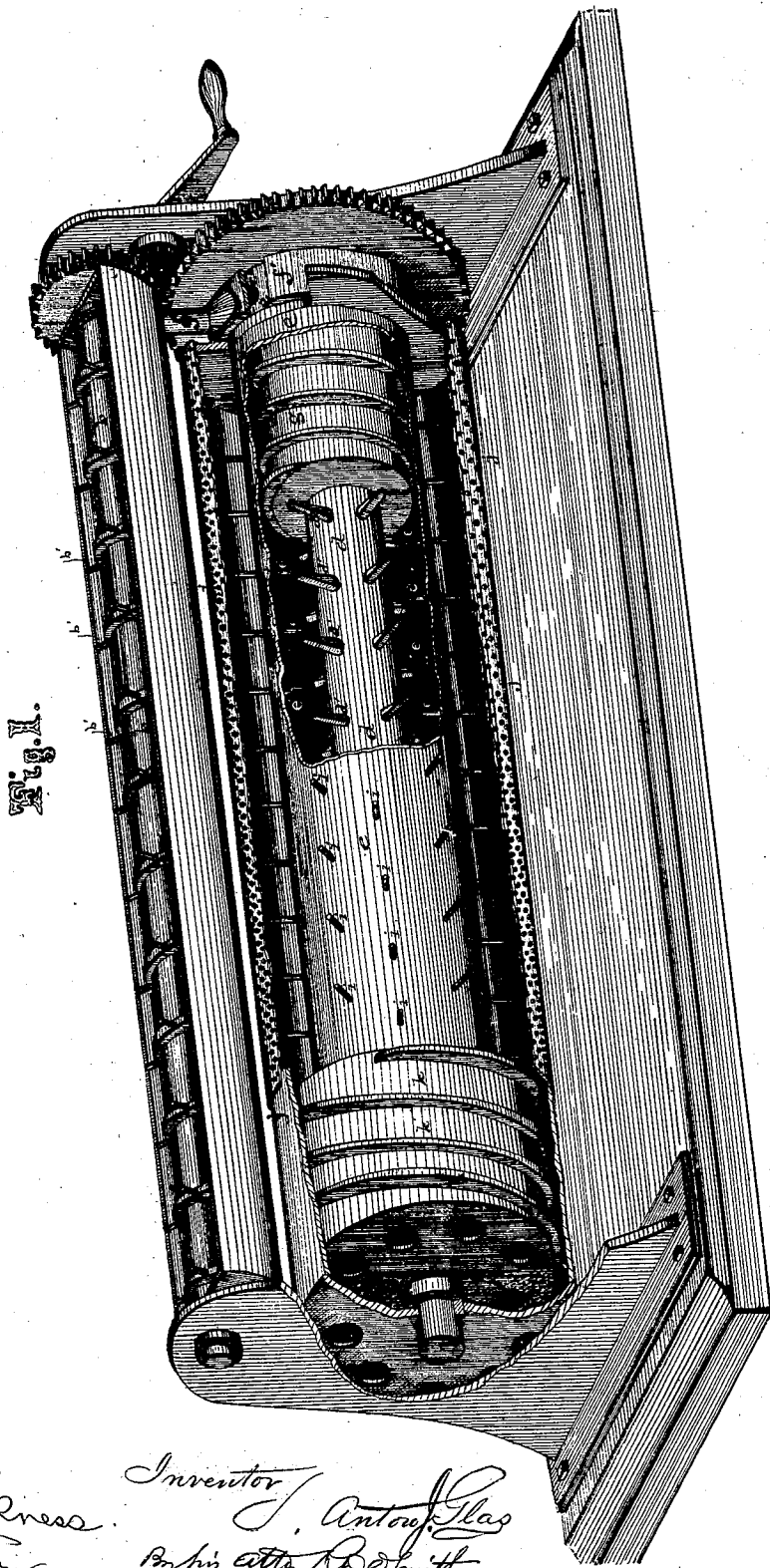

Fig. 1.

Witnesses
J. H. Kress
D. J. Brown

Inventor
A. J. Glas
By his atty R. D. Smith

A. J. GLAS.

APPARATUS FOR DECORTICATING, SEPARATING, AND DRYING GRAIN.

No. 107,480.

Patented Sept. 20, 1870.

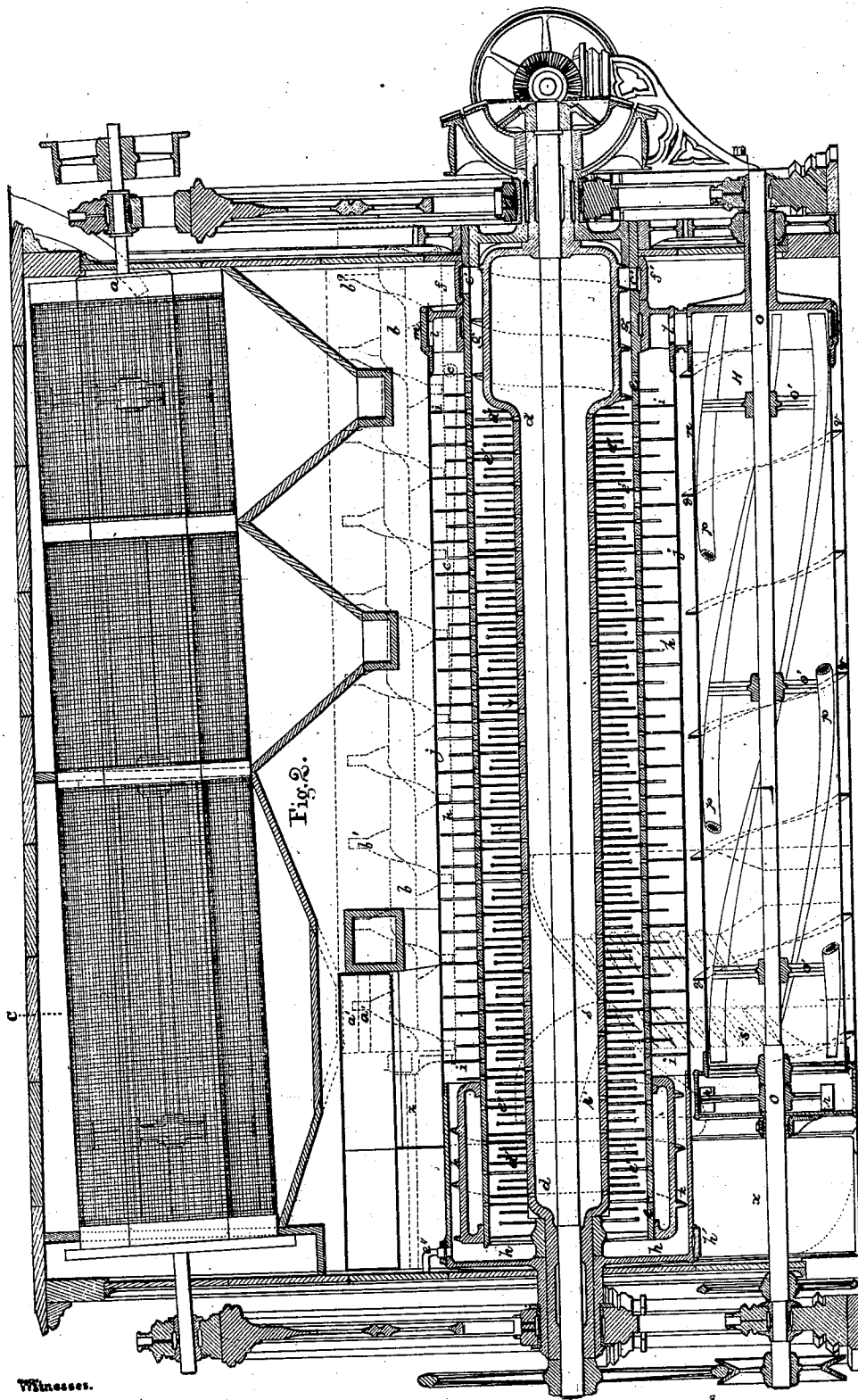
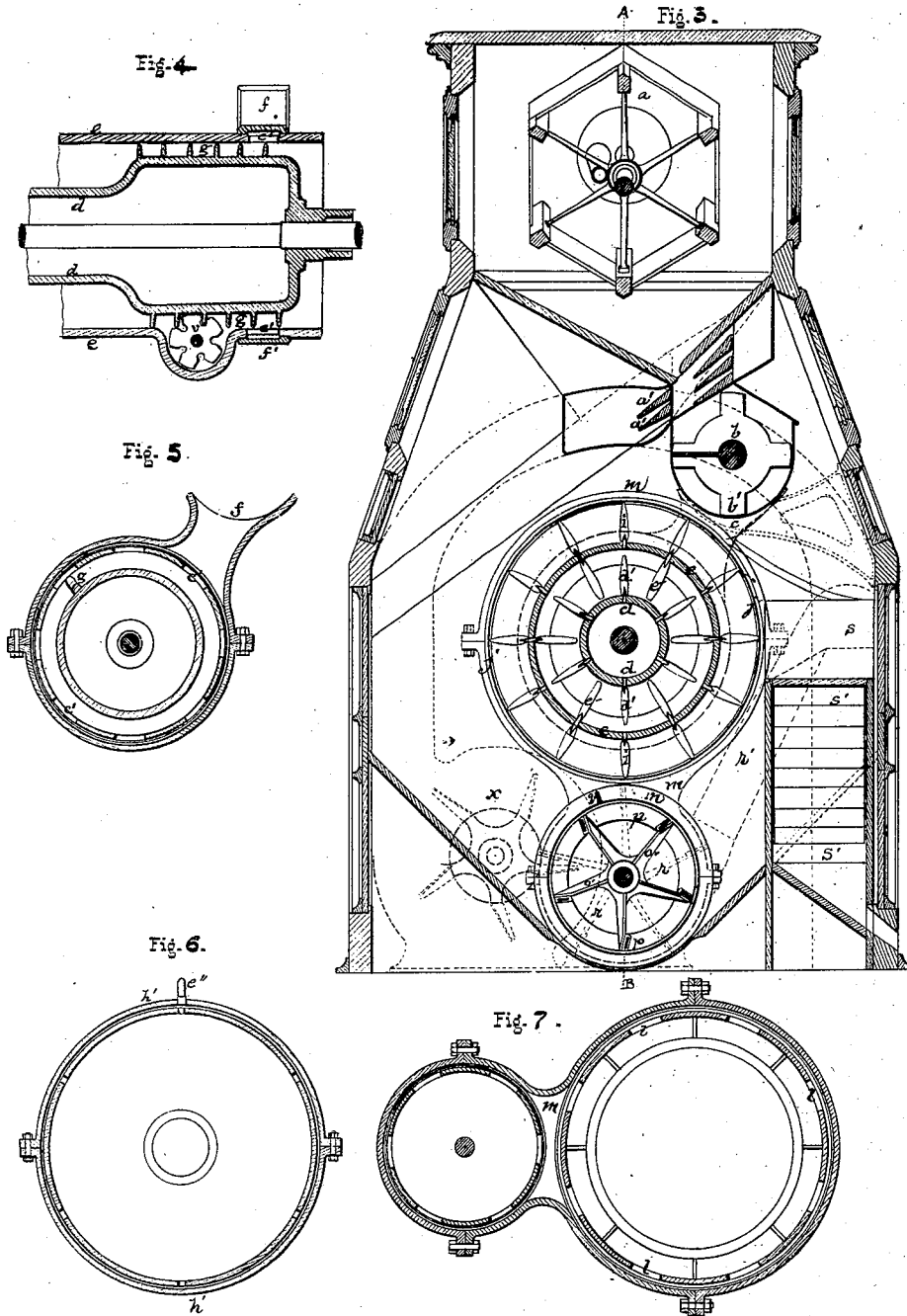

Fig. 2.

Witnesses.

Inventor. *A. J. Glas*
By *his atty R. D. Smith*

A. J. GLAS.
APPARATUS FOR DECORTICATING, SEPARATING, AND DRYING GRAIN.
No. 107,480. Patented Sept. 20, 1870.



Witnesses.

Inventor
A. J. Glas
By *attn. R. D. Smith*

United States Patent Office.

ANTON JOSEPH GLAS, OF LONDON, ENGLAND.

Letters Patent No. 107,480, dated September 20, 1870; patented in England, December 17, 1869.

IMPROVEMENT IN APPARATUS FOR DECORTICATING, SEPARATING, AND DRYING GRAIN, &c.

The Schedule referred to in these Letters Patent and making part of the same

I, ANTON JOSEPH GLAS, of Bedford street, Strand, London, in the county of Middlesex, Great Britain, a subject of the king of Bavaria, Germany, have invented a new Mode of and Apparatus for Decorticating, Separating the Germ, and Drying Wheat or other Grain, of which the following is a specification.

The nature of this invention relates to certain new methods of decorticating, separating the germ, and drying wheat or other grain, wherein the grain may be treated in either the dry or wet state, the latter being effected by an Archimedean screw combined with stirrers, so as to moisten it uniformly at all parts.

According to my arrangement of decorticating and separating the germ from wheat or other grain, a great rubbing friction is set up among the grain by the combined action of knives, and the pressure of an Archimedean screw, which are made to rotate slowly in the opposite direction to each other, so that the decortication, as well as the separation of the germ from wheat or other grain, is effected by the mere frictional contact among the particles themselves, without in the least degree injuring or cutting the inner kernel.

The grain, after being treated as above, is subjected to the action of the beaters. These beaters give a rapid whirling motion to the grain, which produces the final finish, at the same time, the husks and germs are, during this operation, thrown out through the perforated apparatus.

Next, I admit the grain into the fan-elevator, which throws it up into the hopper, where the grain is made to pass through currents of air, in order to separate from it all the husks or other extraneous matters, should any such still be mixed with the grain; also, to separate the grain into two or more different sorts, as may be desirable.

During these operations the drying of the grain is effected to the full extent without any other artificial means.

Description of the Accompanying Drawing.

Figure 1 is a sectional perspective of so much of my invention as is included in this patent.

Figure 2 is a longitudinal section, taken at A B.

Figure 3 is a cross-section, taken at C D.

Figure 4 is a section of another arrangement of feed apparatus.

Figure 5 is a section, taken at the collar of the feed apparatus.

Figure 6 is a section, taken at the collar *c*.

Figure 7 is a section, taken at the discharge-collar *m*.

This invention relates to certain new methods of decorticating, separating the germ, and drying wheat or other grain.

The grain may, according to these plans, be treated in either the dry or wet state, the latter being preferred.

In the first instance, I place the dry grain in a wire-gauze cylinder, *a*, of an improved construction, in order to separate from it the dust, stones, straws, or other foreign matters with which it may be mixed, and, after having passed it through this cylinder *a*, I subject the grain to the action of currents of air, *a'*, produced by the fan *x*, so as to separate all the lighter matters which are of the same size as the grain, and which cannot easily be separated from it by any other means.

Next, if the grain is to be moistened, I submit it to the wetting process, this being effected by admitting to the grain sufficient water, by the pipe *z*, to moisten it to the desired extent, and by subjecting it to the action of an Archimedean screw, *b*, combined with stirrers *b'*. By these means the grain is kept in motion, and is moistened uniformly at all parts, while the water which is not absorbed by it is allowed to escape through the perforated trough *c*, before the grain has passed completely through the moistening apparatus.

When the grain has gone through these operations, I deliver it to the decorticating apparatus, the construction of which may vary considerably in detail, so long as the mode of action, hereinafter described, is adhered to. For instance, one arrangement of this apparatus, which I propose, is shown in the accompanying drawing, where *d*, at figs. 1 and 2, is a horizontal hollow shaft, provided with knives *d'*, which are set round it at convenient intervals, and in a helical line, or nearly so. This shaft *d*, with its knives *d'*, is surrounded by a cylinder, *e*, which is provided with knives *e'*, projecting from its inner surface, so as to form a helical line, having a contrary pitch to that followed by the knives *d'* on the shaft first mentioned. This cylinder *e* is provided, at what I may call its hindmost end, with a feed-pipe, *f*, for supplying it with grain, this pipe *f* communicating with a collar, *f'*, which surrounds the cylinder *e*, and covers the holes *c* in the latter, through which the grain, previously moistened, as above described, is fed into the cylinder *e*, at a regulated rate, as it comes from the moistening apparatus.

The grain, on entering the cylinder *e*, is forced forward toward the knives *d'* and *e'* by means of a short Archimedean screw, *g*, at the hindmost end of the hollow shaft above mentioned. To this shaft, with the knives *d'* and Archimedean screw *g*, as well as to the cylinder *e* surrounding it, I give a slow rotative motion, the motion of the shaft *d* being in the opposite direction to that of the cylinder *e*. Thus, in this arrange-

ment, the grain is forced toward the knives by Archimedean screw *g*, and is then kept in motion by the knives *d* and *e*. The pressure upon the grain caused by the Archimedean screw, combined with the agitation produced by the knives, gives rise to great rubbing friction among the particles of the grain, and the decortication, as well as the separation of the germ, is thus effected by the frictional contact of the particles themselves, without in the least degree injuring or cutting the inner kernel. At the same time, through the combined action of the Archimedean screw and knives, the grain has a progressive motion imparted to it, which carries it toward the foremost end of the apparatus, where, according to the arrangement I am now describing, it is discharged into an annular space, *h*, surrounding the cylinder *e* already mentioned.

Here the method of treatment above explained is repeated, but with less stirring action, a fresh supply of water being added by the pipe *e'* fixed on the collar *k*, as shown at fig. 5, if necessary. Here the grain is acted upon only by the knives *i*, which project from the outer surface of the cylinder *e*, through which it was previously passed. This latter cylinder *e* is itself surrounded by a perforated sheet-iron cylinder, *j*, the annular space *h* between the two cylinders being that to which I have already referred. The outer cylinder *j* is closed at both ends, and is fixed at the foremost end on the shaft *d*, so that it revolves in the opposite direction to the inner cylinder *e*, which carries the knives *e* and *i*.

The grain discharged from the inner cylinder is, by means of a short Archimedean screw, *k*, fixed on the exterior of the cylinder *e*, forced into the annular space *h* between the two cylinders, and is made to traverse this space toward the hindmost end of the apparatus, being subjected on its way to the action of the knives *i* projecting from the exterior of the inner cylinder *e*. These knives give rise to great rubbing action between the particles, which completes the decortivating operation.

During the time the grain is traversing the annular space *h*, the husks will, to a great extent, be discharged through the perforations in the outer cylinder *j*. When the grain reaches the hindmost end of the annular space, it is discharged through holes *l* in the circumference of the outer cylinder *j* into another apparatus, *H*, which is connected by a collar, *m*, to that already described and shown at fig. 6. The apparatus *H*, which now receives the grain, consists of a perforated sheet-iron cylinder, *n*, set horizontally, this cylinder being traversed by a shaft, *o*, having arms *o'*, which support iron bars covered with India rubber, *p*, and bent into a helical line of that pitch

that each bar makes but one-half turn in the whole length of the cylinder. This shaft has a rapid rotatory motion imparted to it, while the cylinder *n* is also made to rotate slowly in the opposite direction, so that there is given to the grain a rapid whirling motion, which produces the final finish; at the same time, the action of the bars causes the grain to progress toward the discharging end of the apparatus, and the husks are, during this operation, nearly, if not all, thrown out through the perforated cylinder, and made to traverse, with those thrown out of the decorticator by the threads *q*, around the cylinder *n* to the hindmost end of the apparatus, while the drying of the grain is also effected during the time it passes these operations, without any other artificial means.

After the grain has passed through the operations above described, and is completely decorticated, as well as free from husks, I admit it into the fan-elevator *r*, which throws the grain up through the spout *r'* into the hopper *s*, where it is subjected to the action of a number of currents of air, *s'*, which are produced by the fan *x*, so as to separate the grain into two or more different sorts, as may be desirable, according to its qualities, and, at the same time, all the husks or other extraneous matters, should any such still be mixed with the grain, will be separated.

Fig. 4 shows, in section, another arrangement of feed apparatus, in which one or more disks are applied, as shown, to prevent the grain from moving round with the Archimedean screw *g*, when the resistance to the grain being forced forward is great. This apparatus will enable the decorticator to be fed under any desired head-pressure, and at any desired rate.

Having thus explained the nature of my invention, I do not claim the whole arrangement of this machine, as some parts are well known to the art.

I claim as my invention—

1. The combination of the cylinder *e* with the Archimedean screw *k* and its knives *e* and *i*.
2. The combination of the Archimedean screw *g* with the disk *v*, in the manner described.
3. In combination with the wetting stirrer *b b'*, the decortivating cylinders *d e*, substantially as set forth.
4. In combination with the cylinder *d*, provided with the screw *g* and knives *d*, the cylinder *e*, provided with knives *e* and the screw *k*, and the perforated jacket cylinder *j*.

ANTON JOSEPH GLAS.

Witnesses:

WILLIAM HENRY MAW.
JAMES DREDGE.