

*J. M. Randle,
Harvester Fork.*

No. 50,328

Patented Oct. 10, 1865.

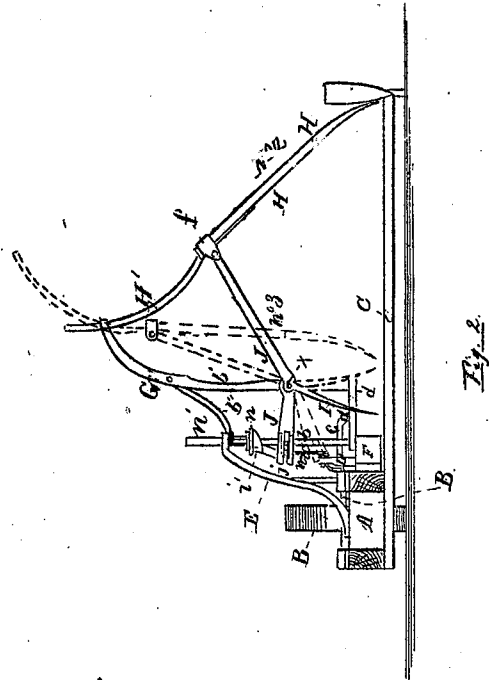

Fig. 2.

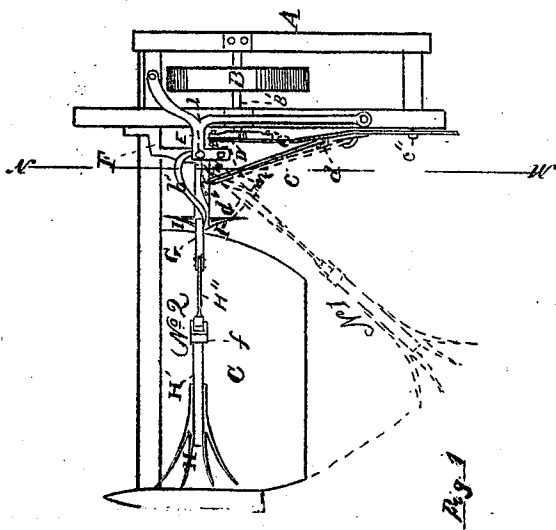

Fig. 1.

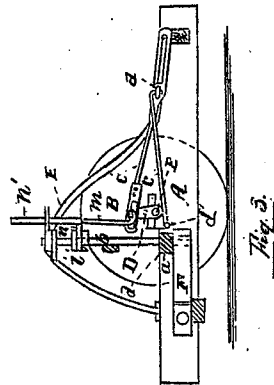

Fig. 3.

Witnesses:

George D. Wagner
A. Wagner.

Inventor:

J. M. Randle
per *Wm. R. Randle*
Att. atty.

UNITED STATES PATENT OFFICE.

JOHN M. RANDLE, OF BRIGHTON, ILLINOIS.

IMPROVEMENT IN HARVESTER-RAKES.

Specification forming part of Letters Patent No. 50,388, dated October 10, 1865.

To all whom it may concern:

Be it known that I, JOHN M. RANDLE, of Brighton, in the county of Macoupin and State of Illinois, have invented a new and Improved Self-Raker for Reaping-Machines; and I do hereby declare that the following is a full, clear, and exact description thereof, reference being had to the accompanying drawings, and to the letters of reference marked thereon, and made to form part of this specification.

Of the annexed drawings, Figure 1 is a plan of the improved rake-attachment fitted to an ordinary reaper, the rakes in said view being shown in two positions, designated as No. 1 and No. 2. Fig. 2 of the drawings represents a front elevation of the improvements in which the rakes are also shown in two positions, and which are designated as No. 2 and No. 3. Fig. 3 is a vertical transverse section of the machine, taken on the line M N in Fig. 1.

The nature of this invention consists in so arranging the rake that sweeps the cut grain from the platform upon which it is thrown after leaving the cutters that the ends of the rake-teeth will, while passing over said platform, describe a straight line parallel to the platform, the machinery for operating the rakes being simply a crank and pitman in connection with a turn-table, all pinions and cog-wheels being dispensed with.

To enable those skilled in the art to make and use my self-rake, I will proceed to describe its construction and operation.

A represents the frame which supports the driving-wheel B, and to which the platform C is attached.

Motion is transmitted to the rakes through the medium of the crank D, which is secured to the inner end of the shaft B' of the wheel B.

Upon the frame A is erected the iron frame E, which should be formed of two braces, and which will serve to support the upper end of the crane or derrick G, which is used for the manipulation of the rakes H I, the lower end of said derrick being erected upon the iron arm F, which is bolted to the inner side of the frame A.

The derrick G is formed of several pieces, as follows, viz: The sill-piece *a* rests on the iron arm F, and the lower end of the post *b* passes through the inner end of the sill and

forms a journal, which enters a suitable journal-box formed in the iron arm F. The upper end of the post *b* also terminates in a journal, which has its bearing in the iron frame E. On the outer end of the sill there is erected the post *b'*, the upper end of which is curved outward to receive the curved rake-rod H'', and this post is connected with the post *b* by means of the curved brace *b''*. The whole derrick thus constructed is made to swing backward and forward around the pivot-point, which is the vertical axis of the post *b*, the limit given to such motion being embraced within an angle of about ninety degrees, more or less. The derrick is made to perform one journey backward and forward at each revolution of the wheel B by being connected with the crank D by means of the connecting-rod *c* and pitman *c'*. The back end of the pitman has a slot which embraces the pin *c''*, so that at every revolution of the crank D the pitman will slide backward and forward on the pin *c''*. The connecting-rod *c* is coupled with the pitman at the ring *d*, and with the sill *a* at *d'*. When the crank D is thrown forward to its horizontal center it will of course cause the pitman and connecting-rod to follow it, and these in turn will push the derrick with its rakes forward until they will assume the position indicated in the drawings, as No. 2 in Fig. 1. When the crank D arrives at its horizontal rear center it will have moved the derrick back to the position indicated as No. 1 in Fig. 1.

The wrist of the crank D is not confined to a fixed position in its bearing in the pitman *c'*, but is permitted to work back and forth for about one-eighth of its revolution in a slot in the end of the said pitman, the detail of which is shown in Fig. 3. The object of this arrangement is to cause the derrick to remain stationary during the time that the rake H is sweeping the grain from the platform, and then when the wrist of the crank suddenly strikes the end of the slot it will cause the derrick to swing suddenly back into the position it is to assume at the moment of depositing the grain upon the field.

The bent lever J is pivoted to the post *b'* at the fulcrum *x*, and the outer end of it is hinged to the strap *f* on the upper end of the rake-rod H', while the other end of it passes a few

inches behind the post *b*, against which it rests, and then terminates in an open-forked end, *j*, which embraces the pin *i*, and by which it is moved up or down, as may be required, as hereinafter described. The pin *i* is secured to the lower end of the sliding head *i'*, which works up and down on the post *b*. A groove around the head *i'* receives the ring *n*, which is fastened to the lower end of the sliding guide *n'*, the upper end of which passes through the upper part of the frame *E*. The pitman *m* connects the sliding guide *n'* with the crank *D*, and thereby transmits a vertical motion to the head *i'*, the effect of which is to alternately raise and lower the forked end of the lever *J*, which, being about one-third of the length of the other end of said lever, will give a correspondingly increased vertical motion to the upper end of the lever *J* at the point where it is joined to the strap *f*.

The rake *H*, which sweeps the cut grain from the platform, is operated by the rake-rod *H'*, which is firmly fastened to the curved rod *H''*, which works up and down through a mortise in the upper end of the curved post *b'*.

The rake *I* is fastened to the lever *J* near its pivot *x*, and consequently has but a small motion laterally. The whole of the parts are united in such a manner that the pin *i* will begin its vertical descent the moment the rake *H* squarely covers the platform, as indicated by position No. 2 in Figs. 1 and 2. As soon as the pin *i* forces the short end of the lever down the other end will raise up the upper end of the rake-rod *H'* and the curved rod *H''* will slide up through the mortise in the end of the post *b'*, the effect of which arrangement will be to give a combined motion to the rake, one of which will be to draw it toward the derrick side of the platform and the other will be to raise the rake and its rods up so that the ends of the rake-teeth will move across the

platform in a straight line and not a curved one, as is the usual manner. The rake will consequently sweep the platform clean at every revolution, although the latter may be perfectly straight and level. The rake *I*, being fastened to the lever *J* near the fulcrum *x*, will at every revolution of the machine be thrown a short distance out toward the platform to meet the rake *H* as it approaches from the other side, and the two will grasp the grain between them as they arrive at that point indicated as No. 3 in Fig. 2. As soon as the rakes arrive at the last-indicated position the connecting-rod *c* will pull the derrick back, so that the rakes will swing clear of the platform, where they can deposit their burden. The next motion of the machine will cause the rake to open by the means already described, and the rake *H* will immediately reassume the position No. 1 in Fig. 1. As the machine revolves these operations will be repeated at every revolution of the wheel *B* and the platform be cleaned at regular intervals of the cut grain.

The advantages of this self-rake are briefly these: It can be applied to any reaping-machine now in use, a curved platform not being necessary. It can be put on and kept in repair by any farmer. Troublesome and expensive cog-wheels are entirely dispensed with. The motions are all simple, but arbitrary.

Having described my invention, what I claim is—

The derrick *G*, in combination with the pitman *c'* and connecting-rod *c*, the pitman *m* and sliding head *i'*, and guide *n'*, the bent lever *J*, and rake-rods *H'* and *H''*, when such parts are constructed and operated as described and set forth.

J. M. RANDLE.

Witnesses:

M. RANDOLPH,
A. WAGNER.