

No. 706,958.

Patented Aug. 12, 1902.

A. A. KELLOGG.
VEHICLE.

(Application filed May 3, 1902.)

(No Model.)

2 Sheets—Sheet 1.

Fig. 1.

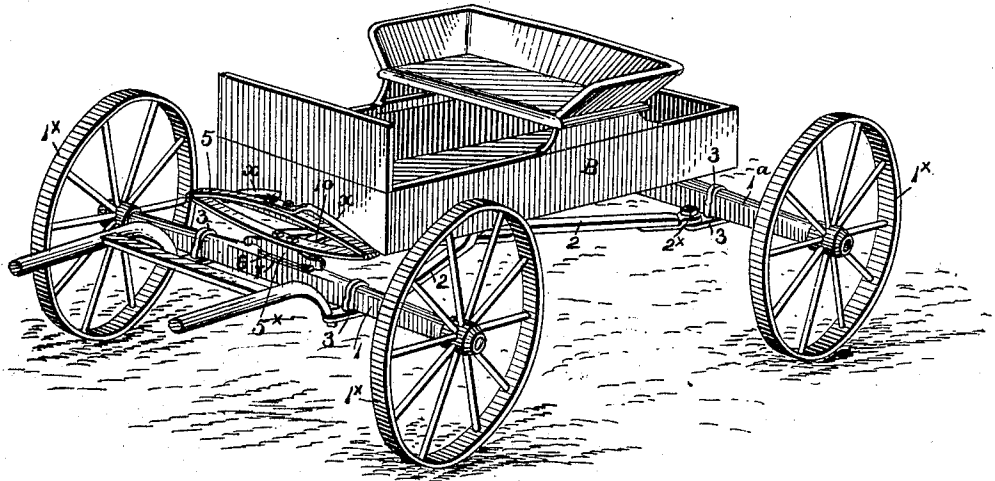
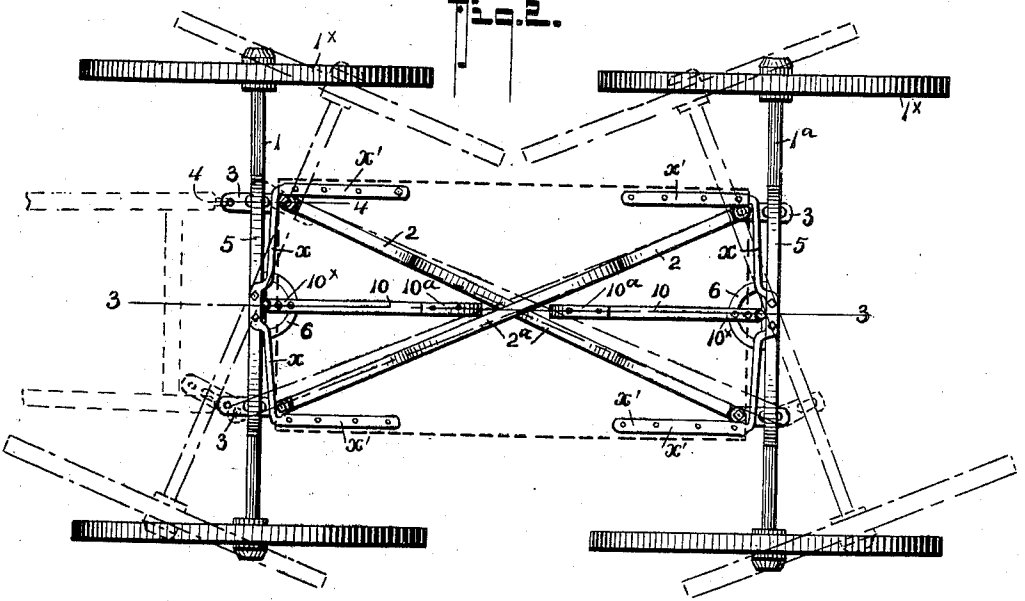

Fig. 2.



WITNESSES;
Louis Dieberich
Leo Kemmer

INVENTOR
A.A. Kellogg.
 BY
Fred G. Dieberich & Co.
 ATTORNEYS.

No. 706,958.

Patented Aug. 12, 1902.

A. A. KELLOGG.

VEHICLE.

(Application filed May 3, 1902.)

(No Model.)

2 Sheets—Sheet 2.

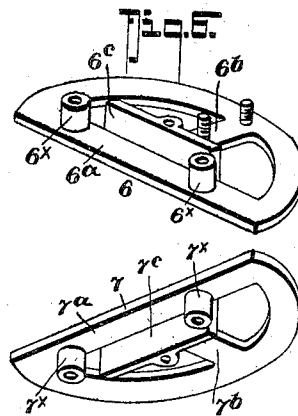
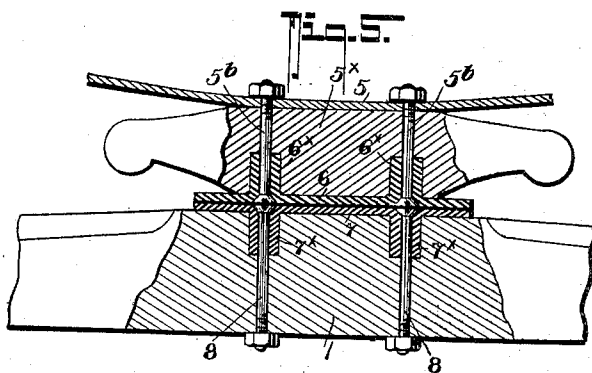
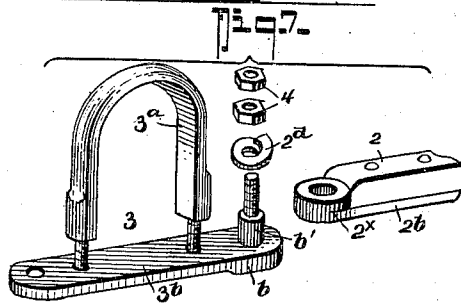
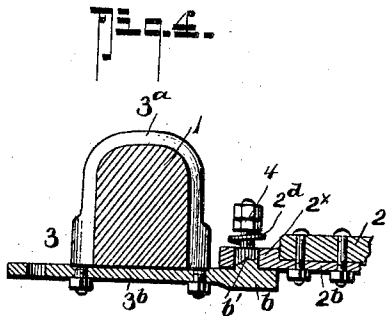
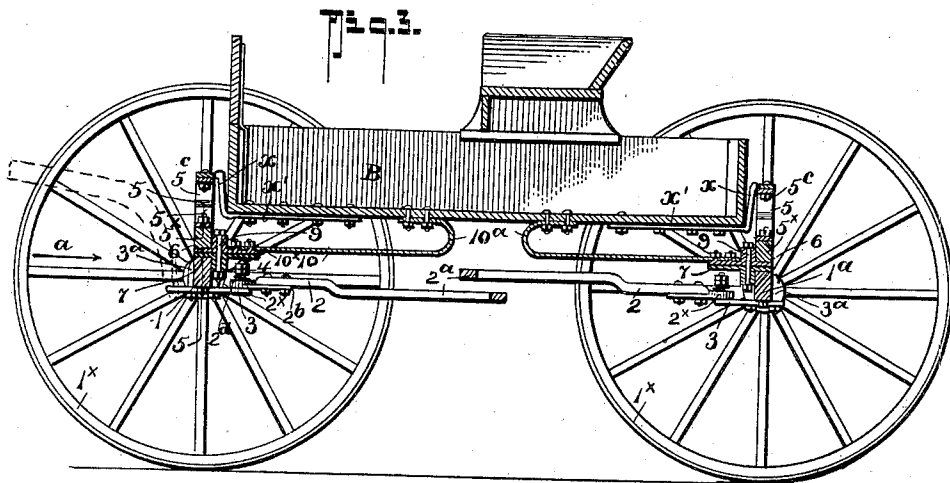

WITNESSES:
Louis Dietrich
Luis Kemou.

INVENTOR
A.A. Kellogg.
BY
Fred Dietrich & Co.
ATTORNEYS.

UNITED STATES PATENT OFFICE.

ALBERT A. KELLOGG, OF CLINTON, MISSOURI, ASSIGNOR OF ONE-THIRD TO
G. C. HAYSLER, OF CLINTON, MISSOURI.

VEHICLE.

SPECIFICATION forming part of Letters Patent No. 706,958, dated August 12, 1902.

Application filed May 3, 1902. Serial No. 105,767. (No model.)

To all whom it may concern:

Be it known that I, ALBERT A. KELLOGG, residing at Clinton, in the county of Henry and State of Missouri, have invented a certain new and useful Improvement in Vehicles, of which the following is a specification.

My invention in its general nature relates to improvements in vehicles, and more specifically to short-turn running-gear in which means are included for turning the front and rear axles simultaneously in opposite directions.

Primarily my invention seeks to provide certain improvements of a simple, economical, and stable character in the type of vehicles referred to whereby to permit of the vehicle turning shorter corners than is possible with the ordinary vehicle and to cause the hind wheels to run clear of obstructions which would not be encountered by the front wheels.

My invention also comprehends a novel correlative arrangement of crossed reach-bars, the wheel-axles, the body-supporting springs, fifth-wheel mechanism, and brace-bars having a special interdependent coaction whereby a simple and positively-operating means is provided for taking the strain off the body-springs when going up or down a hill, for holding the body from swinging forward and backward, and for maintaining the said body-springs in their proper vertical plane and preventing them from rocking laterally on the axles.

In its more subordinate features my invention consists in certain details of construction and peculiar combination of parts, all of which will hereinafter be fully described, and specifically pointed out in the appended claims, reference being had to the accompanying drawings, in which—

Figure 1 is a perspective view of my improved vehicle. Fig. 2 is a plan view thereof, the wagon-body being indicated in dotted lines and a possible position of the front and rear wheels being shown by broken lines. Fig. 3 is a vertical longitudinal section taken on the line 3 3 of Fig. 2. Fig. 4 is a transverse section of one of the reach-coupling members on the line 4 4 of Fig. 2. Fig. 5 is a transverse section taken on the line 5 5, Fig. 3, looking in the direction of the arrow

a. Fig. 6 is a detail perspective view of an upper and a lower fifth-wheel section separated. Fig. 7 is a similar view of one of the reach-coupling members.

In the drawings, in which like numerals and characters indicate like parts in all the figures, 1 1^a designate the front and the rear axles, equipped with the supporting-wheels 1^x 1^x, mounted thereon in the usual manner. These axles are coupled by a pair of crossed reaches 2 2, each of which at the crossing-point is bent, as at 2^a, to prevent binding or contact during the shifting movement thereof. At their ends the reaches are detachably secured to the axles by coupling devices 3, the peculiar construction of which forms one of the features of my invention. These devices, one of which is shown in detail in Figs. 4 and 7, each consist of a Ω -clip 3^a, the bolt ends of which engage the coupling-plate 3^b in the usual manner. At one end the plate 3^b has a lug or extension *b*, formed with an integral stud *b'*, adapted to receive the apertured boss 2^x, forming a part of the plate 2^b, made fast to the under side of the end of the reach 2, as shown, and to hold the boss 2^x from loose play or rattling a spring-washer 2^a is interposed between the upper end of the boss 2^x and the clamping-nut 4.

5 5 designate the body-supporting springs, supported on and in a plane with the longitudinal axis of the axles and mounted on turn-bars 5^x in the usual manner, they being secured to the bars 5^x by the bolts 5^b 5^b, that engage with the bottom members of the springs 5, and, as will be clearly understood by reference to Fig. 1, to the upper member 5^a of the springs 5 is secured the body-supporting straps *x x*, whose separated ends *x' x'* are made fast to the under side of the body B, near its edges, in any approved manner.

In order to prevent backward and forward oscillation of body-springs, it is required that a rigid fifth-wheel construction for each axle be provided which will tend to maintain the spring-holder members or bars in a proper vertical condition under all of the ordinary vibrations of the running-gear and vehicle-body.

By referring now more particularly to Figs. 3 and 6 it will be noticed my construction of

55

60

65

70

75

80

85

90

95

100

fifth-wheel embodies two opposing semicircular plates—an upper one, 6, and a lower one, 7—each having a transverse member 6^a 7^a and a brace 6^b 7^b, that joins the transverse member with the circular portion. The transverse members 6^a 7^a each have integral apertured studs 6^x 7^x, the ones 6^x of the plate 6 being provided to engage sockets in the under side of the body-spring-supporting bar, and the ones 7^x provided to engage sockets in the upper part of the axles, and through the latter the fastening-bolts 8 8 pass, which serve to secure the lower fifth-wheel member firmly to the axle. The upper fifth-wheel members are firmly secured to the under side of their respective spring-carrying bars by the bolts that secure the springs thereto, as shown. The fifth-wheel members 6 and 7 also have integral angle portions 6^c 7^c for engaging the inner face of the axle and the spring-holding bar to provide additional means for rigidly joining with said axle and bar, and each of the portions 6^c 7^c have vertical sockets that aline to receive the king-bolt 9. To further hold the body-springs from rocking laterally and to take off the strain from said springs when going up or down a hill, a brace-bar 10 is provided for each end of the wagon-body, which is in the nature of a spring member having a turned-back end 10^a, adapted to be secured to the under side of the wagon-body. The bars 10 10 are held centrally of the wagon-body and in longitudinal alinement, and the outer or free ends of said bars (designated by 10^x 10^x) are bolted to the brace member 6^a of the upper fifth-wheel sections 6. These brace-bars effectually maintain the wagon-body from swinging forward or backward, and in consequence not only take off undue lateral or crosswise strain on the body-springs, but relieve the bolts that fasten the springs to their supporting-bars, as also the king-bolt, from side strain.

It will be noticed that while the pivotal center of the axles relatively to the body-springs and their support is in a vertical plane with the longitudinal axis of the said body-springs the pivotal or turning fulcrum of said axles—that is, the king-bolt connection—relatively to the crossed reaches is at a point inside of the longitudinal axis of the supporting-springs. This coöperative arrangement of parts has its advantages in that it provides for a perfect coupling of the braces with the fifth-wheels and also for an increased sweep of the wheels in turning, for the reason that when the wagon or buggy stands in a position with the axles at right angles to the body and the distance between the center of the front and rear fifth-wheel to be five feet by turning the draft-pole until the wheels strike the side of the body the distance between the said points will be increased to five

feet two inches or more, according to the distance the crossed reaches are coupled to the axles from the center thereof.

From the foregoing description, taken in connection with the accompanying drawings, it is thought the advantages of my invention will readily appear. I am aware that running-gear including crossed reaches having independent pivotal couplings with the axles have heretofore been provided. My invention differentiates, so far as I know, from running-gear mechanism of the character hereinbefore referred to in the peculiar manner in which the crossed reaches are pivotally joined with the axles, the fifth-wheel arrangement, the longitudinal braces, and the detailed coöperation of the several parts specified, and while I prefer to construct the several devices constituting my invention as described it is apparent that the exact details of parts might be modified without departing from the scope of the appended claims.

Having thus described my invention, what I claim, and desire to secure by Letters Patent, is—

1. As an improvement in vehicles, the combination with the wagon-body, the body-springs, and the supporting-bar for each spring, said springs being connected to the wagon-body, and the front and rear axles; of a pair of crossed reach members, having their opposite ends pivotally joined with the front and rear axles, a fifth-wheel comprising an upper and a lower opposing plate, each plate having integral apertured lugs, adapted to engage sockets in their respective spring-bar, and axle-engaging members, and having integral angle members for engaging the inner sides of the spring-bar and the axle, said angle members having sockets, said sockets adapted to be in alinement and to receive the king-bolt, for the purposes specified.

2. As an improvement in vehicle running-gears, the combination with the axle, the crossed reaches pivotally connected at each end with the said axles, the body-springs, and the supports for the said springs; of the fifth-wheel connections, each comprising a pair of superimposed plates, one of which is rigidly secured to the axle, and the other is rigidly secured to the body-spring holder, each of said plates having sockets at a point inside of the said axle and holder members, to receive the king-bolt, and spring-metal braces rigidly connected to the upper one of said fifth-wheel members, said braces extending in a longitudinal plane of the wagon-body, and having their inner ends fixedly connected thereto, for the purposes specified.

ALBERT A. KELLOGG.

Witnesses:

CHAS. S. ROBINSON,
A. C. HAYSLEER.