

(19) World Intellectual Property Organization
International Bureau



(43) International Publication Date
20 November 2008 (20.11.2008)

PCT

(10) International Publication Number
WO 2008/139214 A1

(51) International Patent Classification:
B64C 1/12 (2006.01) *B64C 3/48* (2006.01)
B64C 3/26 (2006.01)

(74) Agent: BUTLER, Daniel; IP Dept, Building 09A, New Filton House, Filton, Bristol BS99 7AR (GB).

(21) International Application Number:
PCT/GB2008/050294

(81) Designated States (unless otherwise indicated, for every kind of national protection available): AE, AG, AL, AM, AO, AT, AU, AZ, BA, BB, BG, BH, BR, BW, BY, BZ, CA, CH, CN, CO, CR, CU, CZ, DE, DK, DM, DO, DZ, EC, EE, EG, ES, FI, GB, GD, GE, GH, GM, GT, HN, HR, HU, ID, IL, IN, IS, JP, KE, KG, KM, KN, KP, KR, KZ, LA, LC, LK, LR, LS, LT, LU, LY, MA, MD, ME, MG, MK, MN, MW, MX, MY, MZ, NA, NG, NI, NO, NZ, OM, PG, PH, PL, PT, RO, RS, RU, SC, SD, SE, SG, SK, SL, SM, SV, SY, TJ, TM, TN, TR, TT, TZ, UA, UG, US, UZ, VC, VN, ZA, ZM, ZW.

(22) International Filing Date: 24 April 2008 (24.04.2008)

(25) Filing Language: English

(26) Publication Language: English

(30) Priority Data:
0709118.4 14 May 2007 (14.05.2007) GB

(84) Designated States (unless otherwise indicated, for every kind of regional protection available): ARIPO (BW, GH, GM, KE, LS, MW, MZ, NA, SD, SL, SZ, TZ, UG, ZM, ZW), Eurasian (AM, AZ, BY, KG, KZ, MD, RU, TJ, TM), European (AT, BE, BG, CH, CY, CZ, DE, DK, EE, ES, FI, FR, GB, GR, HR, HU, IE, IS, IT, LT, LU, LV, MC, MT, NL, NO, PL, PT, RO, SE, SI, SK, TR), OAPI (BF, BJ, CF, CG, CI, CM, GA, GN, GQ, GW, ML, MR, NE, SN, TD, TG).

(71) Applicant (for all designated States except US): AIRBUS UK LIMITED [GB/GB]; New Filton House, Bristol BS99 7AR (GB).

(72) Inventor; and

(75) Inventor/Applicant (for US only): COSENTINO, Enzo [IT/GB]; c/o Airbus UK Limited, New Filton House, Filton, Bristol BS99 7AR (GB).

Published:
— with international search report

(54) Title: REINFORCED PANEL

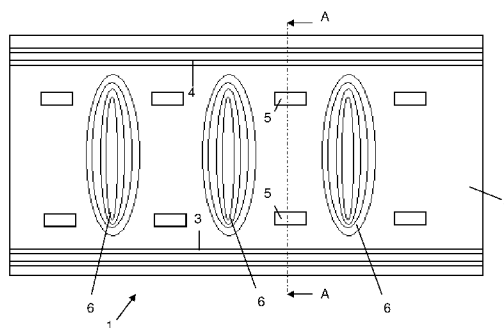

Figure 1

(57) Abstract: A reinforced panel (1) comprising: a compositeskin (2); a plurality of stringers (3, 4) bonded to the skin; and one or more strain actuators (5), each positioned between an adjacent pair of stringers. A load is applied to the panel in the plane of the skin, and a local strain is applied to the skin by the strain actuators when the compressive load exceeds a predetermined threshold. This causes the skin to buckle and reduce interface stresses between the skin and the stringers.

WO 2008/139214 A1

REINFORCED PANEL

FIELD OF THE INVENTION

The present invention relates to a reinforced panel comprising a composite skin; and a plurality of stringers bonded to the skin. The invention also relates to a method of buckling such a reinforced panel.

BACKGROUND OF THE INVENTION

Despite their high level of performance in specific areas, such as weight, durability and through-life costs, composites are not widely accepted in primary structures. This is mostly due to a reduced understanding of the failure mechanisms and of their behaviour when damaged. This widespread lack of knowledge and know-how often leads to over sized structures, which are in contrast with the lightweight philosophy characterizing all the new design solutions.

Buckling still represents one of the most controversial issues of reinforced panel design. It is well known that composite stiffened panels can carry in plane loads higher than the buckling load without any failure. Unfortunately, the complexity and expensiveness of tests to simulate such behaviours associated with the destructiveness of the structure failure, makes the retrieving of failure mechanisms from the debris very complex.

For metallic airframes, stress release and redistribution are intrinsically provided by local plastic deformations and failure occurs by yielding of the skin or by local/global stiffener buckling. Local plasticization happens very seldom in composites, so this method of stress release is generally not available.

SUMMARY OF THE INVENTION

A first aspect of the invention provides a reinforced panel comprising:

- 25 a composite skin;
- a plurality of stringers bonded to the skin; and

one or more strain actuators, each positioned between an adjacent pair of stringers and configured to apply a local strain to the skin which tends to induce buckling of the skin.

A second aspect of the invention provides a method of buckling a reinforced panel, the panel comprising a composite skin and a plurality of stringers bonded to the skin, 5 the method comprising:

applying a load to the panel in the plane of the skin; and

applying a local strain to the skin between an adjacent pair of stringers with one or more strain actuators when the load exceeds a predetermined threshold.

10 The invention recognises that the tension release similar to that which results from local plastic deformation of a metal structure can be achieved in a composite structure by inducing early buckling in the skin.

The load which is applied in the plane of the skin may be compressive load, shear load, or a combination of the two.

15 In one embodiment each strain actuator applies the local strain by changing its geometry between two stable states. In this case each strain actuator may change its geometry automatically without requiring a control system. In other embodiments a control system is provided to monitor strain of the skin and drive the strain actuators when the monitored strain exceeds a predetermined threshold. The strain actuators in 20 this case may for example be piezoelectric devices. The use of a control system for active control and monitoring can enhance the operating load range and provide information on actual structure configuration, behaviour and integrity.

An array of dedicated strain gauges may provide the necessary input to the control system. However more preferably the actuators provide the required sensing input - 25 that is, each actuator is configured to sense the strain of the skin and generate a sensing signal which is monitored by the control system. This reduces the number of control lines required, since each actuator can both transmit sensing signals to the control system and receive drive signals from the control system via a common two-way control line.

The stringers and skin may be bonded together by an adhesive, by co-curing, or by any other suitable bonding method.

The strain actuators may be at least partially embedded in the skin. This may remove the requirement of an adhesive for bonding the strain actuators to the skin.

- 5 In the embodiments described herein, the skin is formed from a composite material comprising a plurality of uni-axial carbon-fibres which are impregnated with epoxy resin. However the skin may be formed from any composite material, including for instance glass-reinforced fibre metal laminate (GLARE).

BRIEF DESCRIPTION OF THE DRAWINGS

- 10 Embodiments of the invention will now be described with reference to the accompanying drawings, in which:

Figure 1 is a plan view of a reinforced panel according to an embodiment of the invention;

Figure 2 is a cross-section taken along a line A-A in Figure 1;

- 15 Figure 3 is an enlarged cross-sectional view of part of the panel;

Figure 4 is a enlarged view of one of the actuators;

Figure 5 shows the electronic control system;

Figure 6 shows a partially embedded actuator;

Figure 7 shows a fully embedded actuator;

- 20 Figure 8 is a cross-section through a fibre carrying a control line;

Figure 9 is a plan view of a reinforced panel employing multi-stable actuators; and

Figure 10 is a graph of Typical Interface Variable versus load.

DETAILED DESCRIPTION OF EMBODIMENT(S)

A portion of a reinforced panel 1 is shown in Figures 1 and 2. The panel may form, for example, the skin of an aircraft wing or fuselage. The panel comprises a composite skin 2; a plurality of composite stringers 3,4 co-cured to the skin; and a two-dimensional array of piezoelectric strain actuators 5 positioned between the stringers. In the case of an aircraft wing, the stringers run in a span-wise direction from the root of the wing towards its tip.

Figure 1 shows only a small portion of the panel, which extends further in both the horizontal and vertical directions. As shown in Figure 2, each stringer comprises a web 3a,4a extending from the skin and a pair of flanges 3b,4b which are bonded to the skin 2.

Each strain actuator 5 is bonded to the skin 1 by an adhesive layer 5a shown in Figures 3 and 4. A pair of electrodes 10a and 10b are bonded to the upper and lower faces of the actuator. Each electrode is connected to a respective control line 11a,11b and the control lines are bundled together in a cable 12 which leads to a control system 13 shown in Figure 5.

The control system 13 drives the actuators by applying a voltage between the electrodes 10a,10b. This causes the actuator to either expand or contract at right angles to the electric field due to the piezoelectric effect. The sign of the voltage determines whether the actuator expands or contracts.

The strain actuators 5 also act as load sensors. When the panel deforms, this causes the strain actuators to expand or contract which, in turn, generates a voltage between the electrodes 10a,10b. This voltage provides a sensing signal which is monitored by the control system 13. The control system 13 generates a drive signal when the monitored voltage exceeds a predetermined threshold stored in a memory 14. This drive signal either increases or decreases the voltage between the electrodes which, in turn, causes the actuator to expand or contract. Note that the sensing signal from the actuators and the drive signal to the actuators may both be carried by the same control line. Deformation of the actuator applies a local strain to the skin which causes the skin to buckle between the stringers to form wrinkles 6 shown in Figures 1 and 2.

Currently, for the majority of aerospace structures, the requirement is that buckling is not allowed below the Design Limit Load. Figure 10 is a graph of Typical Interface

Variable (such as shear load, or out-of-lane displacement at the interface between the skin and the stringer) versus load. In the region between P1 and P2, the panel is pressurised by applying a pressure difference between the opposite faces of the panel. Such a pressure difference will exist in use due, for example, to the existence of pressurised fuel on one side of the skin. In the region between points P1 and P2 an in-plane compressive load is applied to the panel. At point P2 the panel buckles. Thus P2 represents the maximum allowed load, in the absence of strain actuators 5, and the sizing of structures is realized accordingly.

When a pre-pressurized panel reaches the buckling load, a significant change in transverse shape must occur. In fact, in the stable phase the deformed configuration (represented by one wrinkle only -due to the pressure) will turn into a series of wrinkles along the stiffeners' direction in the post-buckling regime. This will happen via a snap-through phenomenon, so an abrupt change of mechanical variables will characterize the transition from the stable regime to the unstable regime. Figure1 illustrates three of such multiple wrinkles 6.

If the external loading acts progressively, then the internal elastic energy instantly before and after the transition must remain the same. It is intuitive that if the same amount of elastic energy is distributed over one wrinkle only or spread over several wrinkles, in the latter case the maximum out of plane displacement characterizing each wrinkle must decrease, so each interface stress component will proportionally decrease. This means that buckling induces a stress release at the interface between the panel and the stringer.

By setting the threshold in the memory 14 below the buckling load P2 (for instance 60% or 80% of the buckling load P2) the actuators 5 enforce a further stress field that tends to induce the skin to buckle before the buckling load P2 is reached. This early buckling causes a subsequent stress release at the co-bonded skin/stiffener interface. The panel will then work in a post-stable regime, and the reduced interface stresses will reach their critical value at higher load levels. As a result the operating load capability will be enhanced and a significant increase in overall performance and weight saving can be achieved.

Figure 6 illustrates an alternative arrangement in which the actuator 5 is partially embedded in a recess in the surface of the skin 2. Figure 7 illustrates an alternative arrangement in which the actuator 5 is fully embedded inside the skin 2. Figure 8 is a schematic view of the fully embedded actuator 5.

5 The skin 2 and stringers 3,4 are each formed from a series of composite layers, each layer comprising a plurality of uni-axial hollow carbon-fibres which are impregnated with epoxy resin. In the partially or fully embedded arrangements shown in Figures 6 and 7, one or both of the control lines 11a,11b may run along the hollow core of a
10 respective carbon-fibre. This is shown in Figure 8, which is a cross section through a hollow carbon fibre 21 containing a control line 11b in its hollow core. The space between the conductive metal control line 11b and the conductive carbon fibre 21 is filled with resin 20 which acts as an insulator.

In an alternative embodiment of the invention shown in Figure 9, the piezoelectric strain actuators 5 are replaced by multi-stable actuators 30 which apply local strain to
15 the skin by changing their geometry between two or more stable states. An example of such a structure is an unsymmetrical laminate. Various unsymmetrical laminate structures are described in:

- "The application of residual stress tailoring of snap-through composites for variable sweep wings", 47th AIAA/ASME/ASCE/AHS/ASC Structures,
20 Structural Dynamics, and Materials Conference, 1 - 4 May 2006, Newport, Rhode Island; and
- Bi-stable composites with piezoelectric actuators for shape change, C.R.Bowen, A.I.T.Salo , R.Butler , E. Chang and H.A.Kim, *Key Engineering Materials Vols. 334-335 (2007) pp. 1109-1112*

25 The simplest example is a square plate with a stacking sequence of $[0^\circ/90^\circ]$. After cool down, the plate which is cured flat at high temperature, shows a cylindrical shape that can be easily snapped into a second cylindrical shape by the application of a force.

In this case no electrical control system or memory is required. Instead, the actuators
30 30 have an inherent material property which causes them to snap between stable states

when the load in the panel exceeds a required threshold, thus causing the skin to buckle early due to the local strain applied by the actuators 30.

Although the invention has been described above with reference to one or more preferred embodiments, it will be appreciated that various changes or modifications
5 may be made without departing from the scope of the invention as defined in the appended claims.

CLAIMS

1. A reinforced panel comprising:
 - a composite skin;
 - a plurality of stringers bonded to the skin; and
 - 5 one or more strain actuators, each positioned between an adjacent pair of stringers and configured to apply a local strain to the skin which tends to induce buckling of the skin.
2. The panel of claim 1 further comprising a control system configured to monitor strain of the skin and drive the strain actuators when the monitored strain exceeds a
10 predetermined threshold.
3. The panel of claim 2 wherein each actuator is configured to sense the strain of the skin and generate a sensing signal which is monitored by the control system.
4. The panel of claim 3 wherein each actuator transmits sensing signals to the control system and receives drive signals from the control system via a common two-way
15 control line.
5. The panel of claim 1 wherein each strain actuator applies the local strain by changing its geometry between two stable states.
6. The panel of any preceding claim wherein the stringers and skin are co-cured.
7. The panel of any preceding claim wherein each strain actuator is bonded to the skin by
20 an adhesive layer.
8. The panel of any preceding claim wherein each strain actuator is at least partially embedded in the skin.
9. The panel of any preceding claim wherein each strain actuator is a piezoelectric device.

10. The panel of any preceding claim wherein the skin is formed from a laminar composite material.
11. A method of buckling a reinforced panel, the panel comprising a composite skin and a plurality of stringers bonded to the skin, the method comprising:
- 5 applying a load to the panel in the plane of the skin; and
- applying a local strain to the skin between an adjacent pair of stringers with one or more strain actuators when the load exceeds a predetermined threshold.
12. The method of claim 11 further comprising monitoring the strain of the skin, and
- 10 driving the strain actuators when the monitored strain exceeds the predetermined threshold.

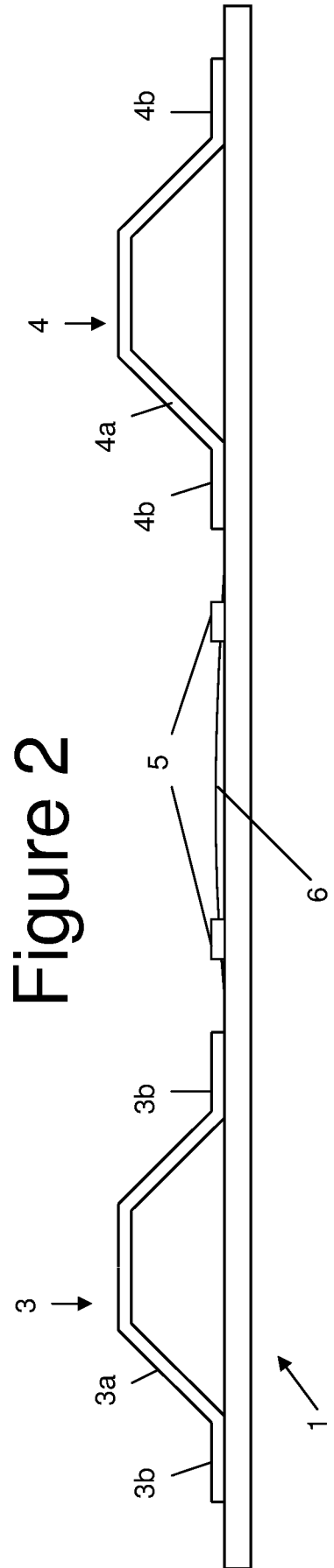
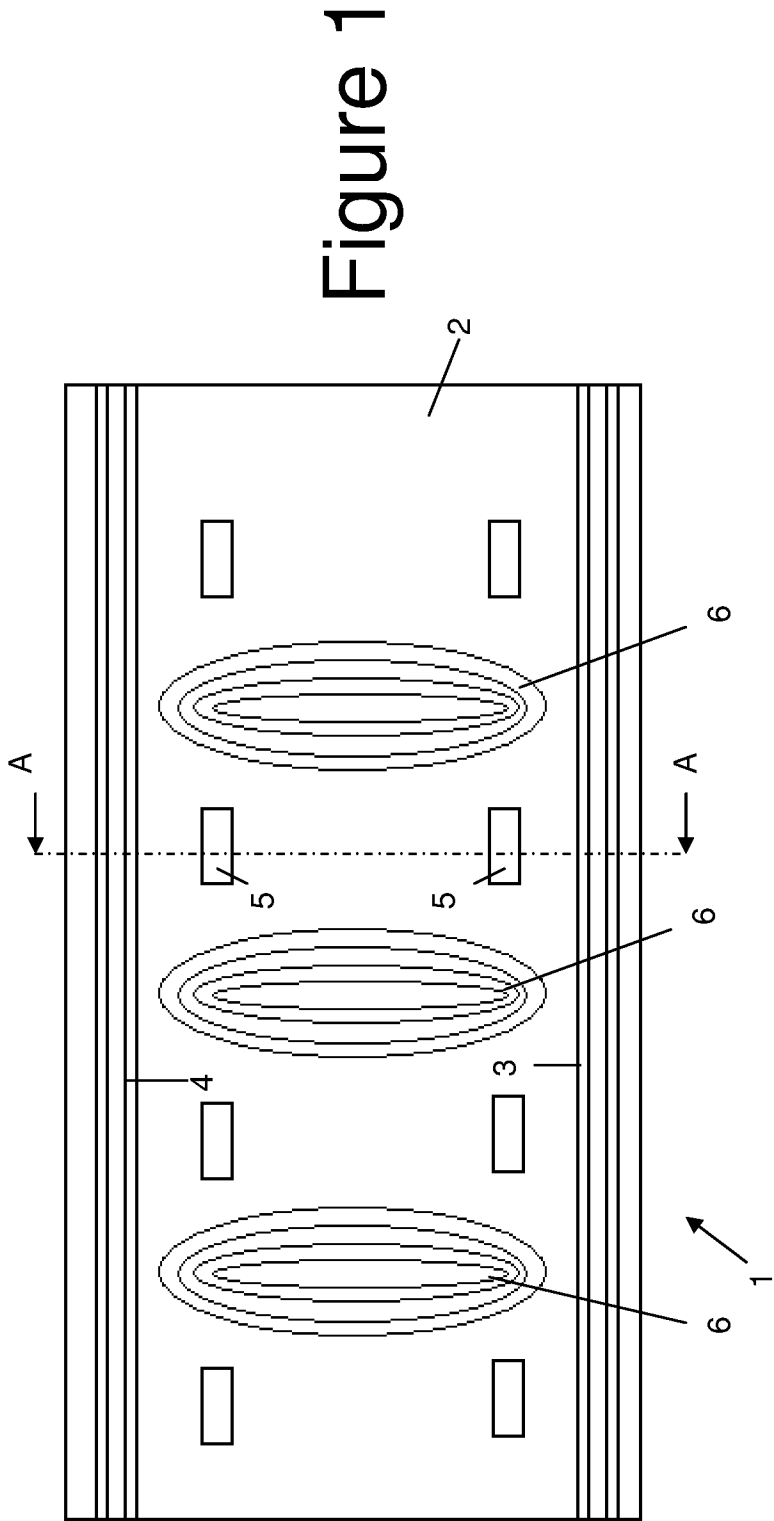

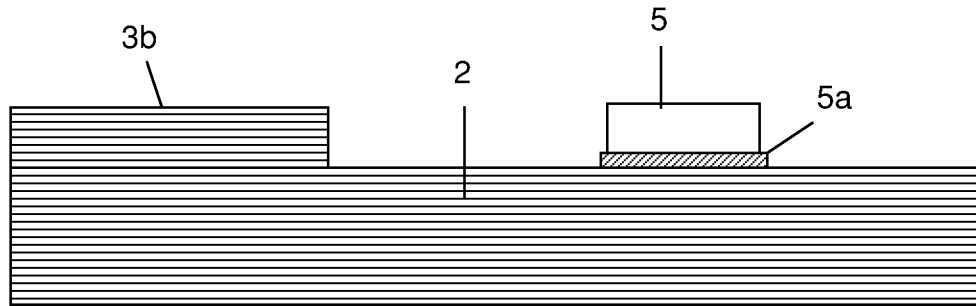

Figure 3

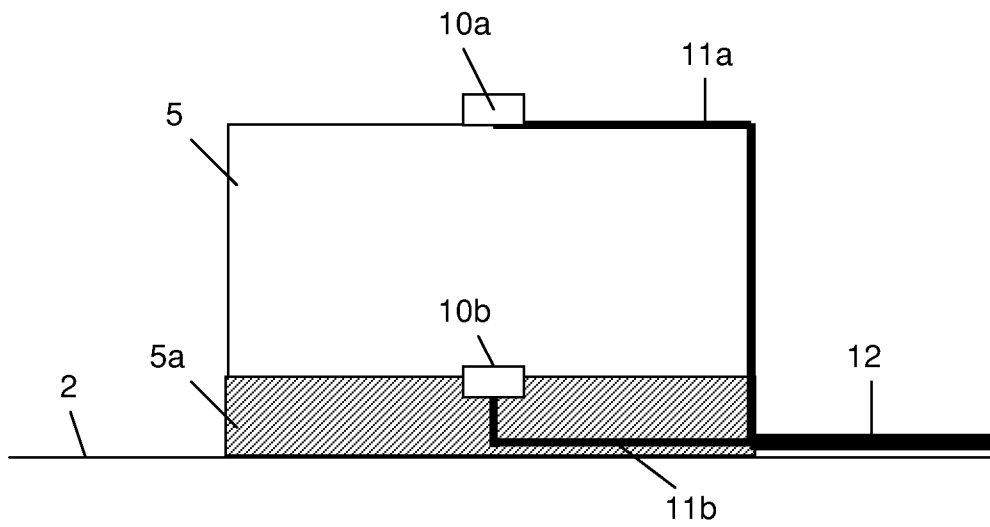

Figure 4

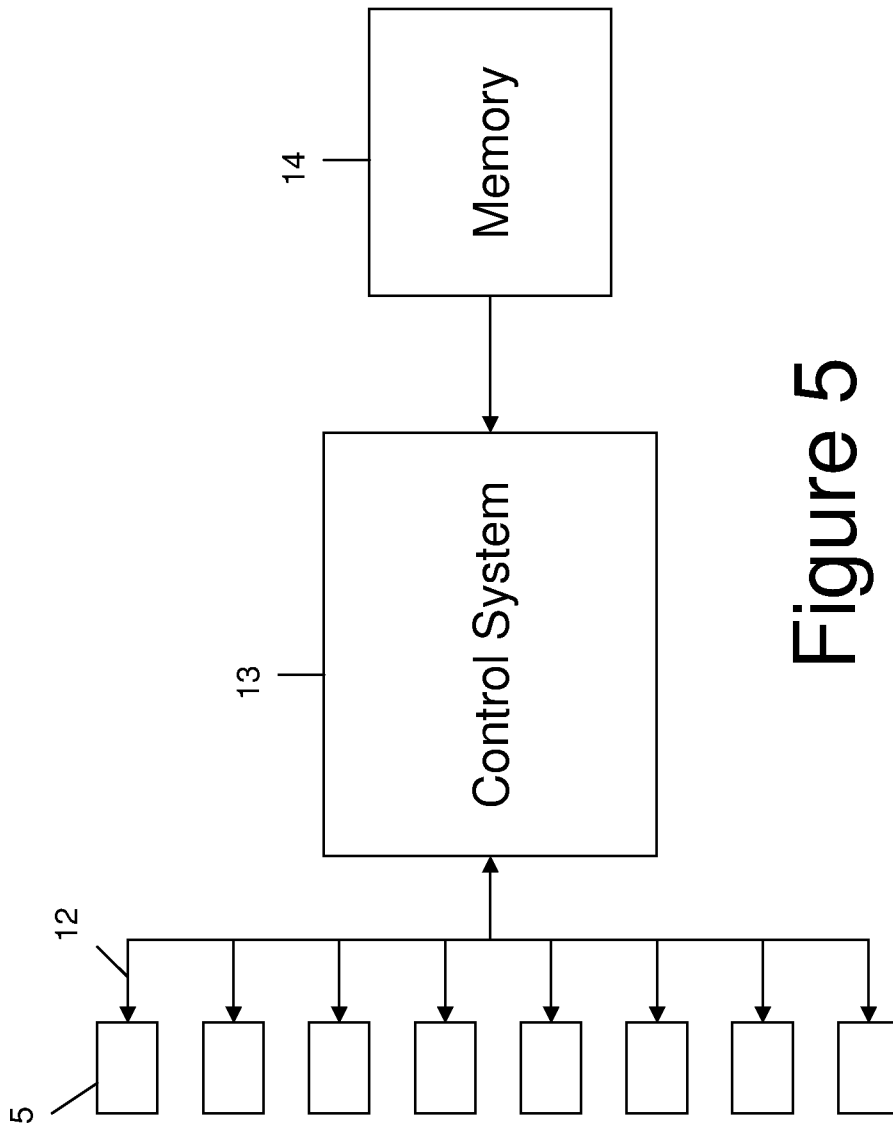

Figure 5

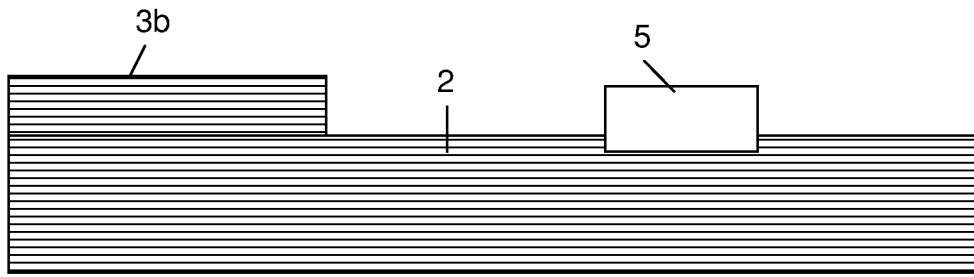

Figure 6

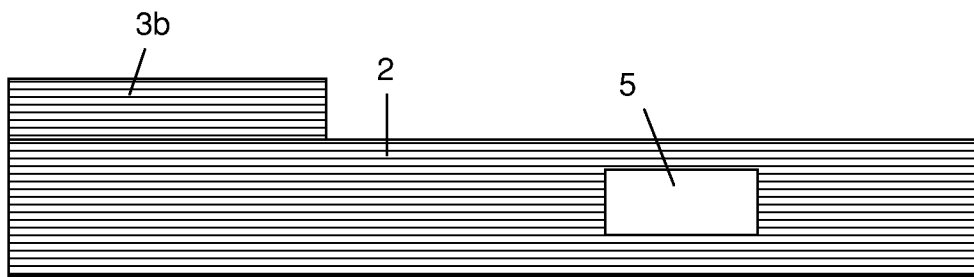

Figure 7

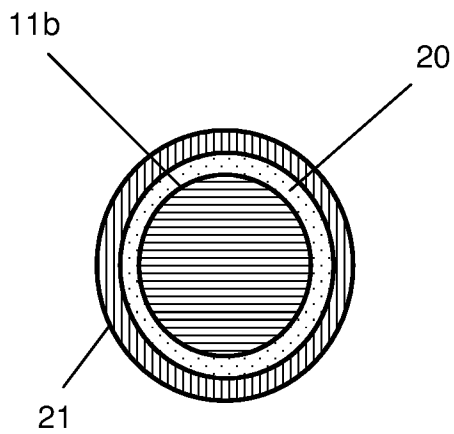

Figure 8

Figure 9

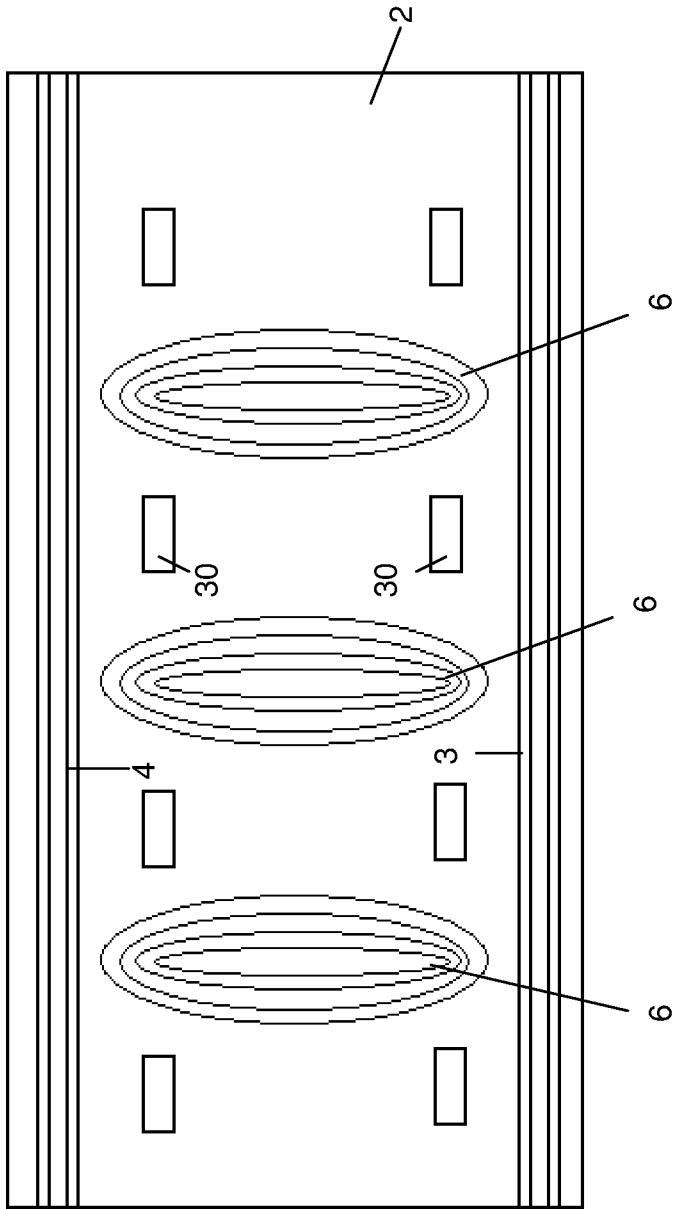
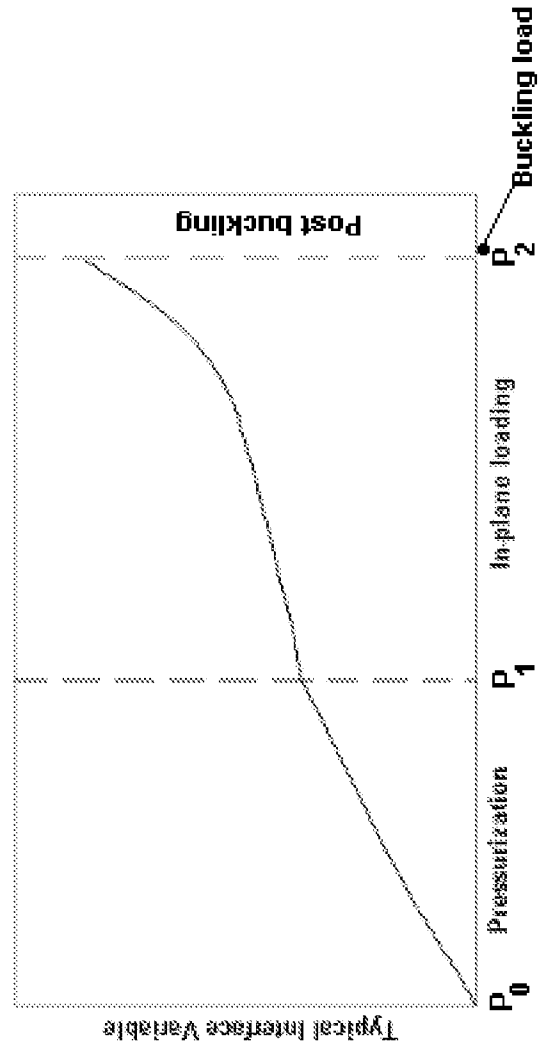

Figure 10



INTERNATIONAL SEARCH REPORT

International application No
PCT/GB2008/050294

A. CLASSIFICATION OF SUBJECT MATTER
INV. B64C1/12 B64C3/26 B64C3/48

According to International Patent Classification (IPC) or to both national classification and IPC

B. FIELDS SEARCHED

Minimum documentation searched (classification system followed by classification symbols)
B64C

Documentation searched other than minimum documentation to the extent that such documents are included in the fields searched

Electronic data base consulted during the international search (name of data base and, where practical, search terms used)

EPO-Internal, WPI Data

C. DOCUMENTS CONSIDERED TO BE RELEVANT

Category*	Citation of document, with indication, where appropriate, of the relevant passages	Relevant to claim No.
X	US 6 010 098 A (CAMPANILE LUCIO FLAVIO [DE] ET AL) 4 January 2000 (2000-01-04) column 1, line 52 - line 62	1,5-11
A	column 3, line 5 - line 9 column 3, line 46 - line 53 column 6, line 22 - line 23 column 6, line 52 - line 64; figure 10	2,12
X	WO 2004/108525 A (FLEXSYS INC [US]; KOTA SRIDHAR [US]; HETRICK JOEL A [US]) 16 December 2004 (2004-12-16) abstract; figures 1a,1b,5a,5b	1,6,10, 11
X	US 6 375 127 B1 (APPA KARI [US]) 23 April 2002 (2002-04-23) abstract; figures 4,8	1,9,11
	----- -/--	

Further documents are listed in the continuation of Box C.

See patent family annex.

* Special categories of cited documents:

- *A* document defining the general state of the art which is not considered to be of particular relevance
- *E* earlier document but published on or after the international filing date
- *L* document which may throw doubts on priority claim(s) or which is cited to establish the publication date of another citation or other special reason (as specified)
- *O* document referring to an oral disclosure, use, exhibition or other means
- *P* document published prior to the international filing date but later than the priority date claimed

- *T* later document published after the international filing date or priority date and not in conflict with the application but cited to understand the principle or theory underlying the invention
- *X* document of particular relevance; the claimed invention cannot be considered novel or cannot be considered to involve an inventive step when the document is taken alone
- *Y* document of particular relevance; the claimed invention cannot be considered to involve an inventive step when the document is combined with one or more other such documents, such combination being obvious to a person skilled in the art.
- *G* document member of the same patent family

Date of the actual completion of the international search

26 June 2008

Date of mailing of the international search report

04/07/2008

Name and mailing address of the ISA/
European Patent Office, P.B. 5818 Patentlaan 2
NL - 2280 HV Rijswijk
Tel. (+31-70) 340-2040, Tx. 31 651 epo nl,
Fax: (+31-70) 340-3016

Authorized officer

Kaysan, Rainer

INTERNATIONAL SEARCH REPORT

International application No
PCT/GB2008/050294

C(Continuation). DOCUMENTS CONSIDERED TO BE RELEVANT

Category*	Citation of document, with indication, where appropriate, of the relevant passages	Relevant to claim No.
A	US 6 152 405 A (MUELLER DIETMAR [DE]) 28 November 2000 (2000-11-28) column 4, line 28 - line 29 column 6, line 25 - line 37; figure 1 -----	1,11
A	EP 1 714 866 A (DEUTSCH ZENTR LUFT & RAUMFAHRT [DE]) 25 October 2006 (2006-10-25) paragraphs [0007], [0011], [0013] - [0016]; figure 1 -----	1,11

INTERNATIONAL SEARCH REPORT

Information on patent family members

International application No

PCT/GB2008/050294

Patent document cited in search report	Publication date	Patent family member(s)	Publication date	
US 6010098	A	04-01-2000	DE 19707392 A1 EP 0860355 A1 ES 2203839 T3	27-08-1998 26-08-1998 16-04-2004
WO 2004108525	A	16-12-2004	BR PI0408101 A CA 2518080 A1 EP 1603798 A1	23-05-2006 16-12-2004 14-12-2005
US 6375127	B1	23-04-2002	NONE	
US 6152405	A	28-11-2000	DE 19643222 A1 EP 0836988 A1	23-04-1998 22-04-1998
EP 1714866	A	25-10-2006	DE 102005018428 A1	26-10-2006