

(No Model.)

C. S. TALLMADGE.
PAINTER'S BURNING LAMP.

No. 251,075.

Patented Dec. 20, 1881.

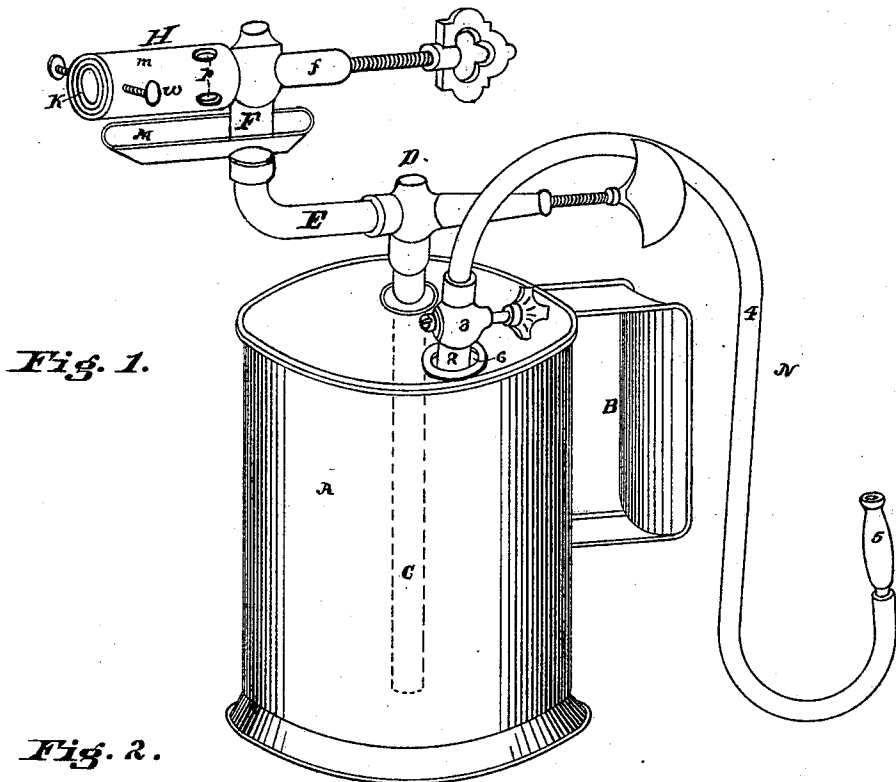

Fig. 1.

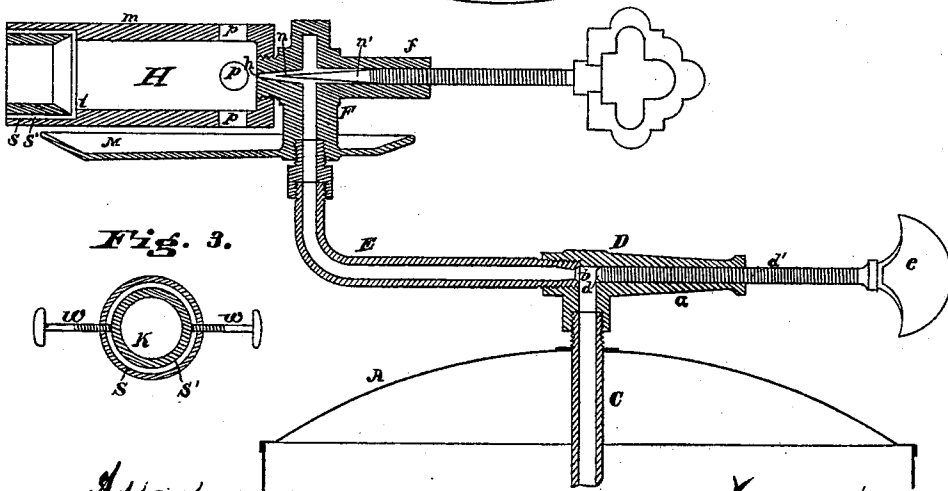

Fig. 2.

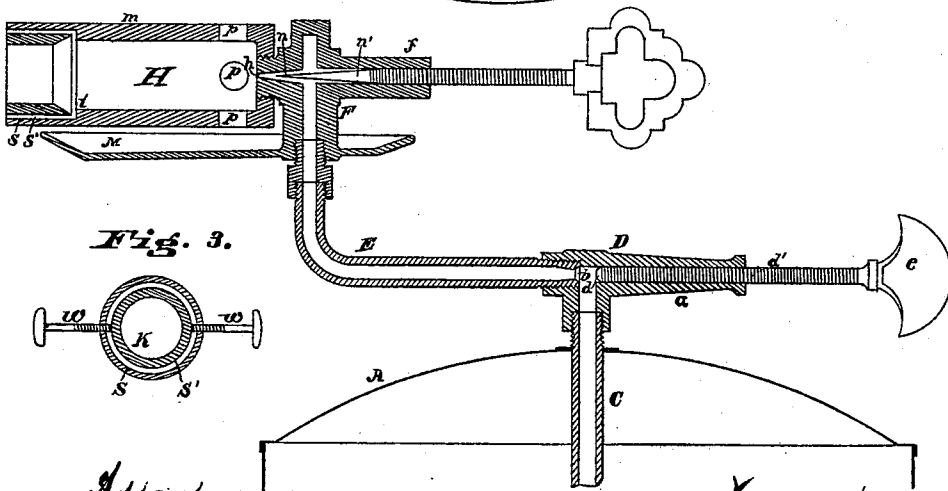

Fig. 3.

Attest

E. Hill
J. M. Stahl

Inventor

Charles S. Tallmadge
By Wm. Hubbell Fisher
Att'y.

UNITED STATES PATENT OFFICE.

CHARLES S. TALLMADGE, OF CINCINNATI, OHIO.

PAINTER'S BURNING-LAMP.

SPECIFICATION forming part of Letters Patent No. 251,075, dated December 20, 1881.

Application filed July 30, 1881. (No model.)

To all whom it may concern:

Be it known that I, CHARLES S. TALLMADGE, of Cincinnati, Hamilton county, State of Ohio, have invented certain new and useful Improvements in Painters' Burning-Lamps, of which the following is a specification.

My invention relates to that class of lamps employed by painters in the removal of paint from wood or other material, the flame of the lamp being directed against and caused to burn the paint. This operation of burning the paint renders the latter soft and loosens its hold on the wood-work or other material to which it was originally applied, and enables it to be readily and easily removed by scraping, &c.

My invention contemplates the use of naphtha or gasoline as the fuel for generating and feeding combustion.

The object of my invention is to provide a cheap, economical lamp, easily operated and applied, and effective in use.

The various features of my invention will become apparent from the following description.

In the accompanying drawings, Figure 1 is a view in perspective of a lamp illustrating my invention. Fig. 2 is a vertical central section of said lamp, taken in a plane passing through the longitudinal center of the burner; and Fig. 3 is a transverse section of the burner.

A designates the can or body of the lamp, which contains the gasoline. The can is preferably provided with the handle B. A tube, C, located within the can and open at its lower end, extends from the top of the can to within a short distance of the bottom of the latter. At the top of the can this tube is connected by a screw-thread, as shown, or in any other suitable manner, to a suitable stop-cock, D, preferably of the kind known as "needle-valve," and shown in the drawings, where *a* is the shell of the valve-seat *b*, inclosing an aperture leading into the pipe or tube E, and *d* a valve whose stem *d'* is provided with a screw engaging a female screw in the stem and operated by a finger or thumb piece, *e*. The valve D is connected to the tube E by a screw-thread, or in any other suitable manner, and this tube is connected in any desired manner, preferably by a screw-thread, as shown, to the tubular

stem F, which is connected to the rear portion or forms a part of stem *f* of the burner H. The tube E is filled with packing, preferably of cotton.

The burner H consists of the usual rear portion, *f*, attached to stem F, and provided with a conduit or opening connected to the opening in stem F, and in its horizontal portion gradually tapering forward to an exceedingly fine orifice at the point *h*, where it enters the cavity of the cylinder *m* of the burner. The tapering shape of the hole affords a proper seat for the valve *n*, which is projected against said seat or retracted therefrom by any suitable means. In the present instance the means consists of a screw-thread on the valve-stem *n'*, which engages a female screw-thread on the interior of portion *f*; and the said valve-stem *n'* is further provided with a thumb or finger piece for rotating it, and thus screwing it forward or backward. The cylinder *m* is screwed, as shown, or otherwise suitably attached, to the portion *f*, and is provided at rear with the usual inlet draft-holes, *p*.

Near or at its mouth or front end the burner *m* is constructed in a novel manner, so as to crowd or force a portion of the flame and burning gases (which would all otherwise issue from the cylinder) back against the rear portion of the cylinder, in order to heat said rear portion, including the valve portion *f*, very hot, and keep the latter at a high degree of temperature. This may be accomplished in various ways—as, for example, by slitting longitudinally the end of the cylinder at several equidistant points on its periphery and bending the slit parts so as to come quite closely together; but the preferable method of construction is that shown in the drawings, and is as follows: The front portion of the cylinder *m* is internally cut away, making an annular recess, S, and a shoulder, *t*. Within this annular recess is placed an annular piece, K, whose outer or peripheral circumference is somewhat less than the diameter of the space inclosed by the cylinder at said annular recess, and the annular piece K is so secured as to be everywhere equally distant from the wall of the annular recess S, and thus an annular space, S', will be everywhere present around the annular piece, and between

that and the wall of the annular recess. In the present instance the means for securing the annular piece K in position consists of two set-screws, *w*, one located on and passing through one side of the cylinder and the other located on and passing through the opposite side of the latter. Each screw engages a female screw in the cylinder and impinges against and is preferably stepped into a step or recess in the adjacent side of the annular piece K. (See Fig. 3.) These set-screws enable the piece K to be easily and quickly removed from the cylinder *m* for the purposes of cleaning or repairing the cylinder *m*, or cleaning or repairing the piece K, and can be as easily and quickly replaced in the cylinder. The inner edge of the rear end of the annular piece K is preferably beveled off, as shown, to deflect the flame and burning gases forward and toward the center of the cylinder, and is placed so that the outer edge of said rear end shall be quite near the shoulder *t*, and yet far enough distant to allow of the passage of a portion of the flame and burning gases between the annular piece K and the wall of the recess S. The annular piece K is preferably made quite thick, and so that the surface-lines of that portion of the cylinder which is behind the recess would, if projected forward, pass through the center of the edge of the annular piece. The object of making the annular piece thick is to present a greater barrier to the outward progress of the flame, &c., and cause a greater portion of the latter to be deflected toward the center of the burner.

A novel and very convenient means for heating the cylinder *m*, valve *n*, stem *n'*, and portions *f* and F consists of the elongated cup basin-shaped receptacle M, located beneath said cylinder, valve, stem, and portions *f* and F, and suitably secured to the portion F. It is preferably cast with the portion F, thus forming an inseparable portion thereof.

The lamp, in order to be properly effective, must have some means whereby the gasoline may be rapidly forced from the car or body A up through the tubes C and E to portion F, and there be rapidly converted into gas and caused to rapidly issue at orifice *h* into the cylinder, thence kindled into flame, and be rapidly forced out through, and to some distance beyond, the mouth of the burner H. Such means is provided in the tube N, consisting preferably of a stiff portion, 2, attached to and opening into the can A, and having a stop-cock, 3, and a flexible portion, 4, provided at its free end with a mouth-piece, 5. The other end of this flexible portion is preferably so made that it can be readily removed from or attached to the end of the stiff portion 2. The free end of the flexible tube may serve as a mouth-piece, when desired, without the addition of mouth-piece 5.

The mode in which the afore-described lamp is operated is as follows: The can is first filled by unscrewing stiff portion 2 of tube N from

the can A, and pouring the gasoline through the orifice 6 thus opened. The stiff portion 2 is then reattached to the can by being screwed into said orifice 6. The valve *d* is closed. The valve 3 is now opened and the painter, applying his mouth to the mouth-piece 5, blows through tube N, and continues so to do until he has condensed the air within the can as far as he is able conveniently to do by blowing with force. He then closes tube N by turning stop-cock 3 and opens valves *d* and *n*. The pressure of the condensed air within the can will force the gasoline into the burner, which gasoline will flow into and fill the basin M. This gasoline is then set on fire and permitted to burn until the cylinder *m* and the valve *n* and portions *f* and F are heated sufficiently hot to cause any gasoline present in said valve and portions *f* and F to be converted into gas. The gasoline thus expanding into gas issues with great force from the orifice *h* of valve *n* and passes into the cylinder *m*, where it is lighted, and the greater portion of it passes out through the cylinder and extends in an almost straight jet of flame some six inches beyond the front of said cylinder *m*, and in a line parallel to the length of the latter. Another portion of the flame passes into the annular space S' and assists in the combustion, causing a blue flame. Another portion of the gas, in consequence of being deflected toward the center of the cylinder, crowds or reflects back a part of the flame and burning gases and forces them against the rear end of the cylinder and the face of portion *f*, thereby keeping the cylinder and portions *f* and F continually hot, and causing these to generate gas from the gasoline passing up from the can.

The lamp is used by applying the flame to the paint to be removed. When the painter no longer needs to use the lamp he turns the valve D and cuts off the supply of gasoline to the burner and the flame is extinguished.

Those features of my invention which consist of the device for deflecting back the flame, &c., and the basin M, and that feature of my invention which consists in an apparatus for enabling the painter to condense the air in the can, as well as to rapidly force the gasoline through the tubes, while preferably used together, may be employed either in connection with one another or separately, as desired; or any two thereof can be used together, as desired. If preferred, any other mode of condensing the air in the can or forcing the gasoline through the tubes may be employed—as, for example, an air-pump may be used; but I do not regard such as convenient or as useful as my device for the same purpose.

Any or all of the various features of my invention can be advantageously used for purposes other than those herein set forth. For example, they can be employed in gas-fitters' lamps, &c.

What I claim as new and of my invention, and desire to secure by Letters Patent, is—

1. In a vapor-burner, the cylinder *m*, provided with the annular piece *K*, located within said cylinder and near the open end of same, substantially as and for the purposes specified.
- 5 2. In a vapor-burner, the cylinder *m*, having an annular recess, *S*, in combination with the annular piece *K*, substantially as and for the purposes specified.
- 10 3. In a vapor-burner, the combination of cylinder *m*, provided with the annular piece *K*, located within the cylinder and near its open end, and appropriate means for securing piece *K* in position within the cylinder, substantially as and for the purposes specified.
- 15 4. In a vapor-burner, the combination of cylinder *m* and annular piece *K*, located within the cylinder and near its open end, and the set-screws *W*, substantially as and for the purposes specified.
- 20 5. The burner consisting of cylinder *m*, needle-valve at rear end, and annular piece *K*, located within the cylinder and at or near its open end, substantially as and for the purposes specified.
- 25 6. The can provided with tube *C*, burner *H*, valve *D*, and valve *n* and connecting-tubes, and the tube *N*, provided with flexible portion 4, stop-cock 3, and mouth-piece 5, substantially as and for the purposes specified.
7. The can provided with tube *C*, burner *H*, 30 valve *D*, and valve *n* and connecting-tubes, and the tube *N*, provided with flexible portion 4, stop-cock 3, and mouth-piece 5, and the handle *B*, substantially as and for the purposes specified.
- 35 8. The can *A*, combined with the burner *H* and valve *D*, and connecting tubes, connected to and supported at the top of the can, and tube *N*, provided with flexible tube 4, substantially as and for the purposes specified.
- 40 9. The can *A*, combined with the burner *H* and valve *D*, and connecting-tubes, connected to and supported at the top of the can, and tube *N*, provided with flexible tube 4, and the handle *B*, substantially as and for the purposes 45 specified.
10. The combination of the burner *H*, basin *M*, valves *n* *D*, tubes *C* *E*, can *A*, tube *N*, and stop-cock 3, substantially as and for the purposes specified.
- 50 11. The combination of the burner *H*, basin *M*, valves *n* *D*, tubes *C* *E*, can *A*, tube *N*, and stop-cock 3, and handle *B*, substantially as and for the purposes specified.

CHARLES S. TALLMADGE.

Witnesses:

WM. E. JONES,

E. R. HILL.