



INTERNATIONAL APPLICATION PUBLISHED UNDER THE PATENT COOPERATION TREATY (PCT)

<p>(51) International Patent Classification ⁶ : H02H 1/04, 3/20, 3/22, 7/00, 9/00, 9/04, H01R 3/00, 25/00, 27/02, 31/00, 33/88, 33/90, 33/92, 33/94</p>	<p>A1</p>	<p>(11) International Publication Number: WO 97/41628 (43) International Publication Date: 6 November 1997 (06.11.97)</p>
<p>(21) International Application Number: PCT/US97/06663 (22) International Filing Date: 18 April 1997 (18.04.97) (30) Priority Data: 08/639,541 29 April 1996 (29.04.96) US (71) Applicant: PARADYNE CORPORATION [US/US]; 8545 126th Avenue North, P.O. Box 2826, Largo, FL 33773 (US). (72) Inventors: BEDINGFIELD, John; 1122 18th SW, Largo, FL 34640 (US). HICKS, Michael, A.; 4100 46th Street N., St. Petersburg, FL 33714 (US). (74) Agent: HORSTEMEYER, Scott, A.; Thomas, Kayden, Horste- meyer & Risley, L.L.P., Suite 1500, 100 Galleria Parkway N.W., Atlanta, GA 30339 (US).</p>	<p>(81) Designated States: BR, CA, CN, JP, KR, MX, RU, European patent (AT, BE, CH, DE, DK, ES, FI, FR, GB, GR, IE, IT, LU, MC, NL, PT, SE). Published <i>With international search report.</i></p>	

(54) Title: METHOD FOR INTERFACING TO A POWERED BUS

(57) Abstract

A circuit card (10) is interfaced to a powered electrical bus by applying power to the circuit card before it interfaces to the electrical bus or by removing power from the circuit card after it has been removed from the bus. This is accomplished using a power cord (20) that connects the equipment's power supply (14) to a mating connector (26) on the card to be inserted or removed. Attaching the power cord (20) to the mating connector (26) of the card (10) disables the output drivers that provide output signals to the equipment's communication bus and places the card in a reset state. This prevents introducing error signals onto the communications bus. Additionally, the contacts on the edge connector are sequenced to prevent applying power to the circuit card before a ground is available. Additionally, the power cord (20) and circuit card (10) are keyed to prevent improper insertion and the power cord includes an inductor (28) to provide surge protection.

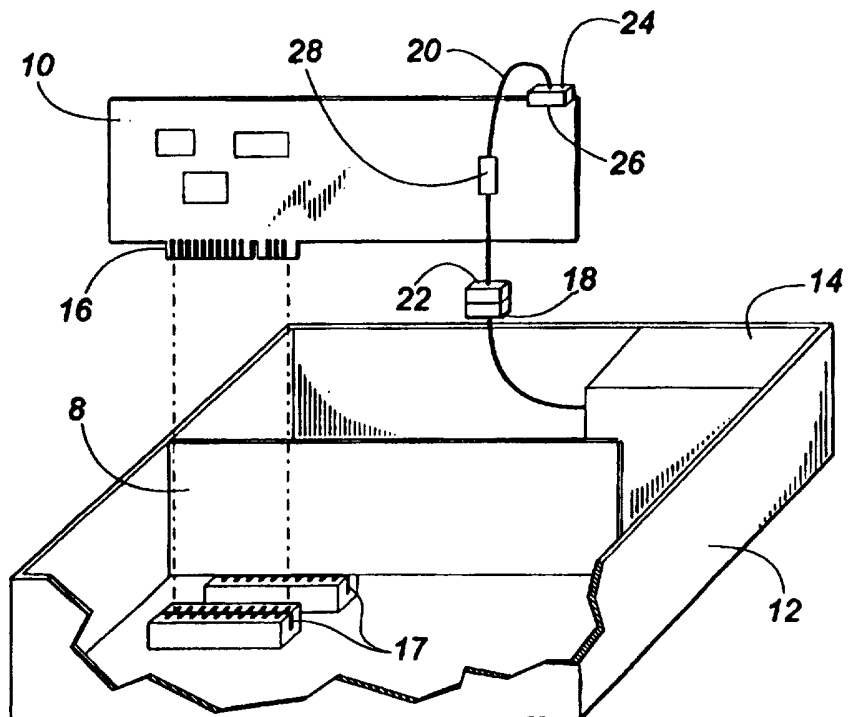

FOR THE PURPOSES OF INFORMATION ONLY

Codes used to identify States party to the PCT on the front pages of pamphlets publishing international applications under the PCT.

AL	Albania	ES	Spain	LS	Lesotho	SI	Slovenia
AM	Armenia	FI	Finland	LT	Lithuania	SK	Slovakia
AT	Austria	FR	France	LU	Luxembourg	SN	Senegal
AU	Australia	GA	Gabon	LV	Latvia	SZ	Swaziland
AZ	Azerbaijan	GB	United Kingdom	MC	Monaco	TD	Chad
BA	Bosnia and Herzegovina	GE	Georgia	MD	Republic of Moldova	TG	Togo
BB	Barbados	GH	Ghana	MG	Madagascar	TJ	Tajikistan
BE	Belgium	GN	Guinea	MK	The former Yugoslav Republic of Macedonia	TM	Turkmenistan
BF	Burkina Faso	GR	Greece			TR	Turkey
BG	Bulgaria	HU	Hungary	ML	Mali	TT	Trinidad and Tobago
BJ	Benin	IE	Ireland	MN	Mongolia	UA	Ukraine
BR	Brazil	IL	Israel	MR	Mauritania	UG	Uganda
BY	Belarus	IS	Iceland	MW	Malawi	US	United States of America
CA	Canada	IT	Italy	MX	Mexico	UZ	Uzbekistan
CF	Central African Republic	JP	Japan	NE	Niger	VN	Viet Nam
CG	Congo	KE	Kenya	NL	Netherlands	YU	Yugoslavia
CH	Switzerland	KG	Kyrgyzstan	NO	Norway	ZW	Zimbabwe
CI	Côte d'Ivoire	KP	Democratic People's Republic of Korea	NZ	New Zealand		
CM	Cameroon	KR	Republic of Korea	PL	Poland		
CN	China	KZ	Kazakstan	PT	Portugal		
CU	Cuba	LC	Saint Lucia	RO	Romania		
CZ	Czech Republic	LI	Liechtenstein	RU	Russian Federation		
DE	Germany	LK	Sri Lanka	SD	Sudan		
DK	Denmark	LR	Liberia	SE	Sweden		
EE	Estonia			SG	Singapore		

METHOD FOR INTERFACING TO A POWERED BUS

Background of the Invention

(1) Field of the Invention:

The present invention relates to electrical equipment; more specifically,
5 interfacing to a bus interface without removing power from that electrical interface.

(2) Description of the Related Art:

In many applications using electrical equipment, it is desirable to provide an uninterrupted service. For example, a computer acting as a server for a local area network should be very reliable because any downtime on the server
10 interferes with many users. In an effort to reduce downtime, electrical equipment typically includes a large amount of redundancy, i.e., several circuit cards performing the same function. This enables the computer or electrical equipment to use one of the redundant electrical cards if a failure occurs in a card presently being used. This permits the equipment to continue operating without producing
15 "downtime". The failed circuit cards should be replaced so as to maintain a high level of redundancy if there are any other additional failures. In the past, replacing circuit cards in equipment not specifically designed for "Hot" insertion, involved powering down or turning off the equipment in which the card is located. This results in an interruption of service to users dependent on the piece of equipment.
20 As a result, it is desirable to replace circuit cards without turning power off to the equipment in which the card is located. When replacing a circuit card without turning power off, there is a danger of applying signals to an unpowered device or introducing unwanted transient conditions onto a communication bus and thereby interfering with the operation of the electrical equipment or possibly causing a
25 failure.

Summary of the Invention

A circuit card is interfaced to a powered electrical bus by applying power to the circuit card before it interfaces to the electrical bus or by removing power from the circuit card after it has been removed from the bus. This is
30 accomplished using a power cord that connects the equipment's power supply to a mating edge connector on the card to be inserted or removed. Attaching the power cord to the mating edge connector of the card disables the output drivers that provide output signals to the equipment's communication bus. This prevents introducing error signals onto the communication bus. Additionally, the contacts on the edge

connector are sequenced to prevent applying power to the circuit card before a ground is available. Additionally, the power cord and circuit card are keyed to prevent improper insertion, and an inductor is included in the power cord to prevent surge currents.

5 **Brief Description of the Drawings**

FIG. 1 illustrates the insertion/removal of a circuit card using a power cord;

FIG. 2 illustrates the circuit card of FIG. 1 and its keyed edge connectors; and

10 FIG. 3 illustrates the upper edge connector of the circuit card of FIG. 2.

Detailed Description of the Invention

FIG. 1 illustrates the insertion/removal of circuit card 10 from personal computer 12. Personal computer 12 includes power supply 14. Signals including power, data and control signals are distributed throughout computer 12 by an electrical bus such as an ISA bus. Other types of standard and nonstandard buses may be used. Edge connector 16 of circuit card, 8 and 10 interface with one of connectors 17 which are in electrical contact with the computer's electrical bus. Typically, in a computer system, power supply 14 includes a unused power connector such as power connector 18. Power connector 18 is connected to power cord 20. Power cord 20 includes connector 22 which mates with connector 18 of power supply 14. At the other end of power cord 20 is connector 24 which mates with edge connector 26 of circuit card 10. It should be noted that other types of mating connectors with sequenced power and ground contacts may be used in place of connectors 24 and 26. Power cord 20 should also include surge filter 28. Surge filter 28 may be a commercially-available surge filter or a simple inductor.

When circuit card 10 is to be inserted into personal computer 12 without turning off power supply 14, power cord 20 is used. Initially, connector 22 of power cord 20 is mated with connector 18 of power supply 14. Next, connector 24 of power cord 20 is mated with edge connector 26 of circuit card 10. Edge connector 26 and connector 24 are keyed so that they only mate in one way and therefore cannot be accidentally reversed. When connector 24 is mated with connector 26, the contacts on edge connector 26 are sequenced so that ground contact is made before power contact is made. Additionally, connector 24 shorts together some contacts on edge connector 26 so that the circuitry on circuit card 10 is put in a benign state. Alternatively, connector 24 may apply ground or power to one or more contacts of

connector 26 to place the circuit card in a benign state. For example, a benign state is a state where driver circuitry that electrically interfaces to computer 12's bus through edge connector 16 is disabled and the circuitry on circuit card 10 is put in a reset, known or predetermined state so that incorrect signals are not put on to the bus
5 when the drivers are enabled.

After connectors 24 and 26 are mated, circuit card 10 is inserted into computer 12 so that edge connector 16 mates with connector 17 of computer 12's electrical bus. As was with edge connector 26, edge connector 16 is keyed to prevent improper mating between edge connector 16 and connector 17. After edge
10 connector 16 is mated with the connector of the electrical bus, power cord 20 is disconnected by disconnecting connectors 24 and 26, and optionally disconnecting connectors 22 and 18. Circuit card 10 has now been mated with computer 12's bus without powering down power supply 14 while preventing incorrect signaling on the bus.

15 Circuit card 10 can be removed from computer 12 without powering down power supply 14 by first connecting connector 22 to connector 18 and then connector 24 to connector 26. After power cord 20 has been installed, circuit card 10 may be removed by disengaging connector 16 from connector 17. After connector 16 has been disengaged, connectors 24 and 26 may be disengaged to remove the
20 card.

FIG. 2 illustrates circuit card 10. Circuit card 10 includes edge connector 16 and edge connector 26. It also includes electrical components such as electrical components 30. Edge connector 26 has keyway 32 which mates with a corresponding key of connector 24. Electrical contacts 38 of edge connector 26 mate
25 with electrical contacts within connector 24. Similarly, edge connector 16 has keyway 40 which mates with a corresponding key of connector 17. Connector 17 is electrically connected to computer 12's bus. Electrical contacts 42 of connection 16 mate with electrical contacts within connector 17.

FIG. 3 is an enlargement of edge connector 26. Keyway 32 is visible. It
30 should be noted that contacts 38 are sequenced. For example, contacts 50, 52, 54, 56 and 64 are connected to ground conductor of circuit card 10 and contacts 58, 60, and 62 are connected to the power conductors of circuit card 10. Since the ground connection contacts are closer to the edge of edge connector 26, they will make contact with their corresponding contacts of connector 24 before contact is made
35 between power contacts 58, 60 and 62, and their corresponding contacts of connector 24. This provides a sequenced connection where ground contact is made before power contact is made. Additionally, reset contact 65 is shorted to ground 64 when

connector 24 is attached. This sets circuit board 10 into a benign or reset state so that when the board is eventually enabled onto computer 12's bus, the circuit board is enabled from a known state and thereby prevents sending incorrect signaling over the bus.

The invention claimed is:

- 1 1. A method for interfacing a circuit card to a powered electrical bus,
2 comprising the steps of:
3 applying a current to the circuit card using a power conductor and a
4 return conductor that interface between a power source and a first electrical interface
5 on the circuit card; and
6 interfacing the circuit card to the powered electrical bus by mating a
7 second electrical interface on the circuit card to the powered electrical bus.

- 1 2. The method of claim 1, wherein the step of applying a current
2 comprises surge filtering the current provided to the circuit card.

- 1 3. The method of claim 1, wherein the step of applying a current
2 comprises electrically interfacing the return conductor to a return contact of the first
3 electrical interface before electrically interfacing the power conductor to a power
4 contact of the first electrical interface.

- 1 4. The method of claim 1, wherein the step of applying a current
2 comprises disabling a driver circuit that electrically interfaces to the powered
3 electrical bus, the driver circuit being located on the circuit card.

- 1 5. The method of claim 4, further comprising the step of enabling the
2 driver circuit after the second electrical interface is mated to the powered electrical
3 bus.

- 1 6. The method of claim 1, wherein the step of applying a current
2 comprises placing a circuit located on the circuit card into a predetermined state.

- 1 7. A method for interfacing a circuit card to a powered electrical bus,
2 comprising the steps of:
3 applying a current to the circuit card using a power conductor and a
4 return conductor that interface between a power source and a first electrical interface
5 on the circuit card, the return conductor being electrically interfaced to a return
6 contact of the first electrical interface before electrically interfacing the power
7 conductor to a power contact of the first electrical interface;

- 8 surge filtering the current provided to the circuit card;
- 9 disabling a driver circuit that electrically interfaces to the powered
- 10 electrical bus, the driver circuit being located on the circuit card;
- 11 interfacing the circuit card to the powered electrical bus by mating a
- 12 second electrical interface on the circuit card to an electrical interface of the powered
- 13 electrical bus; and
- 14 enabling the driver circuit after the second electrical interface is mated
- 15 to the electrical interface of the powered electrical bus.

INTERNATIONAL SEARCH REPORT

International application No.
PCT/US97/06663

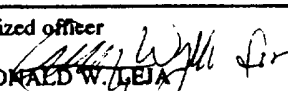
A. CLASSIFICATION OF SUBJECT MATTER IPC(6) :Please See Extra Sheet. US CL :Please See Extra Sheet. According to International Patent Classification (IPC) or to both national classification and IPC		
B. FIELDS SEARCHED		
Minimum documentation searched (classification system followed by classification symbols) U.S. : 361/18, 56, 58, 91, 110, 111; 323/908; 439/163, 640, 924.1, 928.1, 945, 946, 947, 952		
Documentation searched other than minimum documentation to the extent that such documents are included in the fields searched NONE		
Electronic data base consulted during the international search (name of data base and, where practicable, search terms used) NONE		
C. DOCUMENTS CONSIDERED TO BE RELEVANT		
Category*	Citation of document, with indication, where appropriate, of the relevant passages	Relevant to claim No.
X	US 4,510,553 A (FAULTERSACK) 09 APRIL 1985, Figures 1, 2A-D & 5, col. 5, lines 14-52.	1-7
X	US 5,268,592 A (BELLAMY et al.) 07 December 1993, Figure 1, col. 3, line 45 through col. 4, line 47.	1-7
<input type="checkbox"/> Further documents are listed in the continuation of Box C. <input type="checkbox"/> See patent family annex.		
* Special categories of cited documents:		*T later document published after the international filing date or priority date and not in conflict with the application but cited to understand the principle or theory underlying the invention
*A document defining the general state of the art which is not considered to be of particular relevance		*X document of particular relevance; the claimed invention cannot be considered novel or cannot be considered to involve an inventive step when the document is taken alone
*E earlier document published on or after the international filing date		*Y document of particular relevance; the claimed invention cannot be considered to involve an inventive step when the document is combined with one or more other such documents, such combination being obvious to a person skilled in the art
*L document which may throw doubts on priority claim(s) or which is cited to establish the publication date of another citation or other special reason (as specified)		*Z document member of the same patent family
*O document referring to an oral disclosure, use, exhibition or other means		
*P document published prior to the international filing date but later than the priority date claimed		
Date of the actual completion of the international search 06 JUNE 1997	Date of mailing of the international search report 09 JUL 1997	
Name and mailing address of the ISA/US Commissioner of Patents and Trademarks Box PCT Washington, D.C. 20231 Facsimile No. (703) 305-3230	Authorized officer  RONALD W. LEJA Telephone No. (703) 308-2008	

INTERNATIONAL SEARCH REPORT

International application No.
PCT/US97/06663

A. CLASSIFICATION OF SUBJECT MATTER:

IPC (6):

H02H 1/04, 3/20, 3/22, 7/00, 9/00, 9/04; H01R 3/00, 25/00, 27/02, 31/00, 33/88, 33/90, 33/92, 33/94

A. CLASSIFICATION OF SUBJECT MATTER:

US CL :

361/18, 56, 58, 91, 110, 111; 323/908; 439/163, 640, 924.1, 928.1, 945, 946, 947, 952