

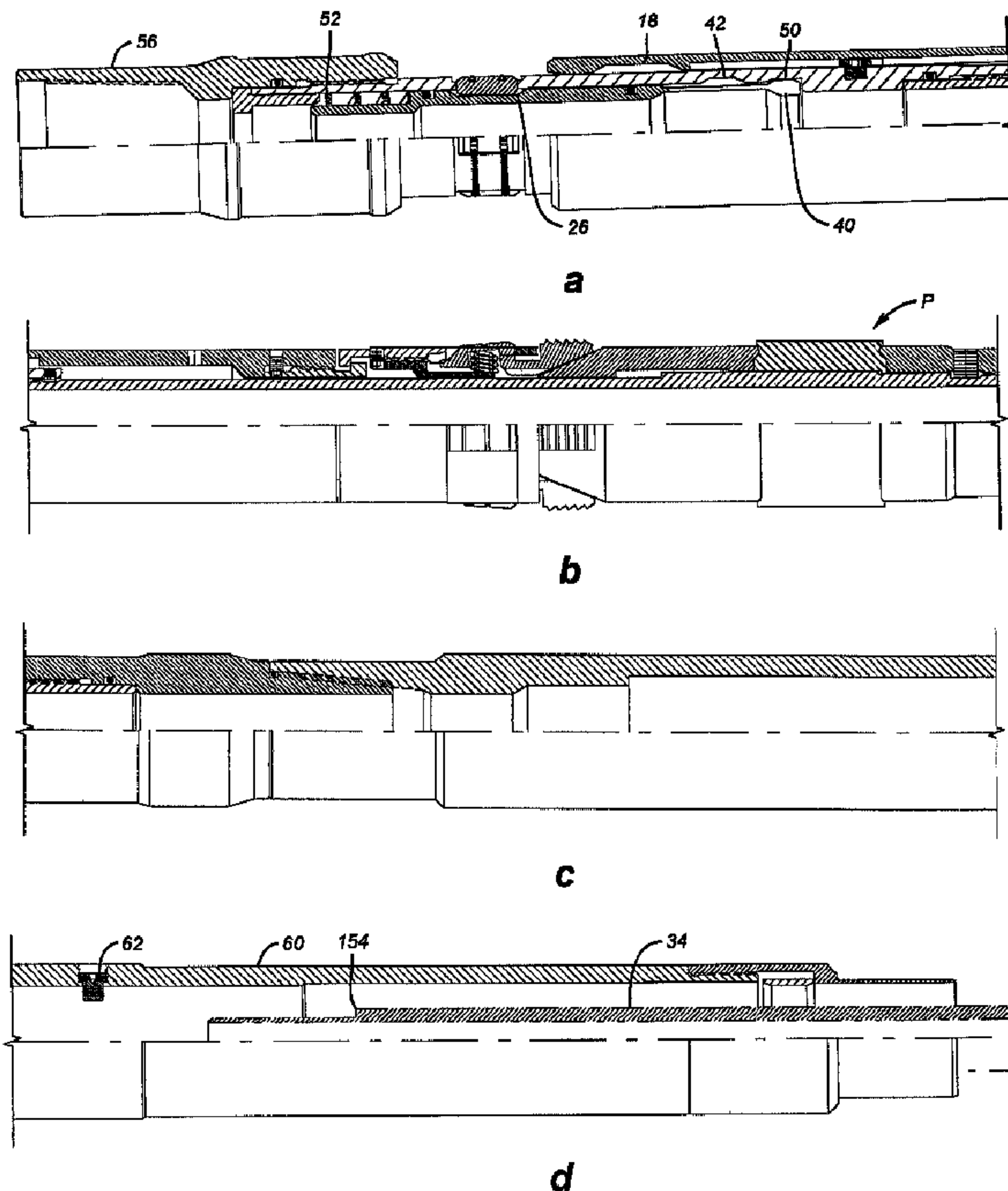

(22) Date de dépôt/Filing Date: 1999/06/09
 (41) Mise à la disp. pub./Open to Public Insp.: 1999/12/10
 (45) Date de délivrance/Issue Date: 2007/12/04
 (62) Demande originale/Original Application: 2 274 203
 (30) Priorité/Priority: 1998/06/10 (US09/095,507)

(51) Cl.Int./Int.Cl. *E21B 23/08* (2006.01)
 (72) Inventeurs/Inventors:
 HENLEY, DAVID A., US;
 MCMAHAN, MICHAEL E., US
 (73) Propriétaire/Owner:
 BAKER HUGHES INCORPORATED, US
 (74) Agent: SIM & MCBURNEY

(54) Titre : METHODE ET APPAREIL POUR LE POSITIONNEMENT ET REPOSITIONNEMENT SANS TOURNOIEMENT
 D'UNE PLURALITE D'OUTILS DANS UN FORAGE
 (54) Title: METHOD AND APPARATUS FOR POSITIONING AND REPOSITIONING A PLURALITY OF SERVICE TOOLS
 DOWNHOLE WITHOUT ROTATION



(57) **Abrégé/Abstract:**

A method and apparatus is disclosed for downhole remediation. In the preferred embodiment, a bridge plug and service packer can be run into a well on coiled or rigid tubing. The assembly is capable of being set without rotation. The service packer is locked

(57) **Abrégé(suite)/Abstract(continued):**

against setting until it is separated from the bridge plug. Setting of the bridge plug closes a passage within it that had been open to facilitate circulation during run-in. The service packer is set with longitudinal movements using an indexing mechanism. At the conclusion of the procedure, the service packer is released and lowered to recapture the bridge plug. The bridge plug is equalized and released to allow the assembly to be repositioned elsewhere in the wellbore or retrieved. The spacing between the packer and bridge plug can be varied as desired.

ABSTRACT OF THE INVENTION

A method and apparatus is disclosed for downhole remediation. In the preferred embodiment, a bridge plug and service packer can be run into a well on coiled or rigid tubing. The assembly is capable of being set without rotation. The service packer is locked against setting until it is separated from the bridge plug. Setting of the bridge plug closes a passage within it that had been open to facilitate circulation during run-in. The service packer is set with longitudinal movements using an indexing mechanism. At the conclusion of the procedure, the service packer is released and lowered to recapture the bridge plug. The bridge plug is equalized and released to allow the assembly to be repositioned elsewhere in the wellbore or retrieved. The spacing between the packer and bridge plug can be varied as desired.

**TITLE: METHOD AND APPARATUS FOR POSITIONING
AND REPOSITIONING A PLURALITY OF SERVICE
TOOLS DOWNHOLE WITHOUT ROTATION**

5 **INVENTOR(S): DAVID A. HENLEY and MICHAEL E. McMAHAN**

FIELD OF THE INVENTION

10 The field of this invention relates to methods and equipment to allow running of a plurality of service tools downhole together and to deploy them where desired and redeploy them in the well, all preferably without rotation of at least one of the tools from the surface.

BACKGROUND OF THE INVENTION

15 As techniques have become more sophisticated for locating subterranean reservoirs, wellbores have become more deviated in an effort to extract the hydrocarbons from below the surface. Coiled tubing has become more prevalent in running tools downhole. Even if rigid tubing is used in a deviated wellbore, actuation of downhole tools using rotation becomes difficult. With
20 the downhole tools supported on coiled tubing, rotation is not possible as part of a technique to set or release downhole tools.

25 Many reservoir treatment procedures require isolation of a specific zone in the wellbore and the application of fluids to the formation in the isolated zone. In order to accomplish this, the zone is generally isolated between a bridge plug located below and a service packer above. A work string is connected to the service packer for access between the two isolation devices so that, for example, the formation can be acidized between the bridge plug and the service packer above. In many situations, the process must be

repeated at multiple locations. One technique that has been used in the past where multiple locations need to be isolated is that the lowermost location has an expendable bridge plug set below it and the service packer is run on a work string to define the first zone to be treated. When the next zone needs to be treated, the service packer is removed from the wellbore and another expendable bridge plug is inserted to define the lower portion of the next zone to be isolated. The service packer is then run in the hole again and the next zone is isolated. This process is repeated until all zones to be treated have been isolated in a similar fashion. At the conclusion of the treatment or procedure, the service packer is removed and all the bridge plugs which have been placed in the wellbore are milled out. There are distinct disadvantages in this procedure in that it requires multiple trips in and out of the well with the service packer so that subsequent bridge plugs can be deployed. Each of the bridge plugs must be separately run in the well and ultimately milled out. Thus, improvements to this technique have generally involved reducing the mill-out time for all the bridge plugs that are in the wellbore. One way this has been accomplished is to make the bridge plugs of generally soft, nonmetallic components so that they can be drilled quickly. Typical of such plugs which are designed to be easily drilled out are U.S. Patents 5,224,540 and 5,271,468 issued to Halliburton.

Another way to accomplish the goal of servicing discrete portions of a wellbore in one trip is to use a straddle tool which has a pair of packers which can be set and unset as desired. One of the disadvantages of this type of a tool is that the distance between the packing elements on the tool is defined at the surface when the bottomhole assembly is put together. These tools,

typically referred to as "wash tools," are illustrated in U.S. patents 4,815,538; 4,279,306; 4,794,989; 5,267,617; 4,962,815; 4,569,396; and 5,456,322.

Another method of isolating and treating zones is accomplished by running a retrievable bridge plug below a service packer. The coupled system is run just below the zone of interest, the bridge plug is set and uncoupled from the service marker. The service packer is then moved up the hole just above the zone and set by rotation and weight to complete the zone isolation. When treatment is complete, the service packer is unset, moved downhole to recouple with the bridge plug, then unset and moved up the hole to repeat the operation.

Service packers and bridge plug systems that individually set with rotation and setdown force are known. These packer/bridge plug combinations have been used in the procedure described above involving one trip to accomplish straddles of different zones. Typical of such packers are the Retrievamatic® and model G retrievable bridge plug offered by Baker Oil Tools and the RTTS service packer and 3L bridge plug offered by Halliburton. Tension-set packers, involving a rotation and pickup force, are also known. Typical of these are the Baker Oil Tools Model C "Full Bore" service packer and the Model C cup-type bridge plug.

What is desirable and is an object of the present invention is to provide an apparatus and method to allow isolation of zones of various lengths in a wellbore by allowing deployment of isolation devices where desired where the isolation devices are actuated without rotation. Another objective of the present invention is to allow redeployment of the isolation devices in different locations in the wellbore without a trip out of the well. More particularly, where

rotation is not possible, the objective is to allow for the deployment and rede-
ployment and separation downhole between the isolation devices, using fluid
pressure and/or longitudinal movements only. Yet another objective of the
present, when used with a bridge plug and a service packer, is to keep the
5 service packer locked against setting while the bridge plug is being set.
Thereafter, when the service packer is separated from the set bridge plug, the
act of separation unlocks the service packer, allowing it to be subsequently
set on further manipulations when it reaches its desired location in the well-
bore. Yet another objective is to allow the bottomhole assembly to be open
10 to circulation during run-in and closed off when the bridge plug is set. The
bridge plug can be equalized by reopening a passage therethrough prior to
release of the bridge plug. These and other objectives of the present inven-
tion will be more apparent to those of skill in the art from a review of the
preferred embodiment described below.

15

SUMMARY OF THE INVENTION

A method and apparatus is disclosed for downhole remediation. In the
preferred embodiment, a bridge plug and service packer can be run into a well
on coiled or rigid tubing. The assembly is capable of being set without rota-
20 tion. The service packer is locked against setting until it is separated from the
bridge plug. Setting of the bridge plug closes a passage within it that had
been open to facilitate circulation during run-in. The service packer is set
with longitudinal movements using an indexing mechanism. At the conclusion
of the procedure, the service packer is released and lowered to recapture the
25 bridge plug. The bridge plug is equalized and released to allow the assembly

to be repositioned elsewhere in the wellbore or retrieved. The spacing between the packer and bridge plug can be varied as desired.

Accordingly, in one aspect of the present invention there is provided a method of setting a sealing device downhole, comprising:

- 5 flowing fluid through a body;
- creating pressure in said body, said pressure causing slips on said body to move to an engaged condition;
- applying a force to said body so that said body engages a sealing element; and
- 10 closing a valve in a bore of said body using said applied force.

According to another aspect of the present invention there is provided a retrievable sealing device for downhole use, comprising:

- a body having a bore along a longitudinal axis, said bore comprising a valve; and
- 15 slips and a sealing element on said body, said slips being movable by backpressure created by flow through said bore to an engaged condition, said sealing element being actuable by a force in the direction of said longitudinal axis of said body with said slips in said engaged condition, said valve closing as a result of said force.

BRIEF DESCRIPTION OF THE DRAWING

Figures 1a-f are a sectional elevational view of the bridge plug and packer in the run-in position.

5 Figures 2a-d illustrate the bridge plug in the set position with the packer pulled away.

Figures 3a-d illustrate the packer in a set position after being pulled away from the bridge plug.

10 Figures 4a-e illustrate the packer released and the bridge plug recaptured prior to the release of the bridge plug.

Figure 5 illustrates the position of the pin in a J-slot mechanism for the packer in the run-in position.

15 Figure 6 illustrates the position of the pin in a J-slot for the bridge plug in the bridge plug set position just before release of the service packer from the bridge plug.

Figure 7 is the view of Figure 5, showing the movement of the pin in the J-slot as the packer is set in tension.

Figure 8 is the view of Figure 7, with the pin in the J-slot position for recapture of the bridge plug.

20 Figure 9 is the view of Figure 6, with the pin in the position where the bridge plug has been captured and released.

DETAILED DESCRIPTION OF THE PREFERRED EMBODIMENT

In the preferred embodiment, a packer **P** and a bridge plug **BP** are connected together for run-in to a wellbore (not shown) on coiled tubing or threaded tubing or drill pipe (not shown) which is secured to the assembly at thread **10**. In the run-in position, relative movement between the cone **12** and the slips **14** is not possible. The reason for this is that the slips **14** are connected through a series of components to ratchet housing **16**. Ratchet housing **16** has a groove **18**. A series of segmented locking dogs **20**, held together by garter springs **22**, are locked into groove **18** by virtue of lock collet member **24**. Lock collet member **24** has a groove **26** which, when aligned with dogs **20**, allows them to exit from groove **18**. The slips **14** are pivotally mounted to swivel retainer **28** and are biased outwardly by concentric springs **30**. By design, surface **32** is intended to rub on the tubing or casing (not shown) to provide temporary support for the packer **P** in the setting operation as will be described below. When the bridge plug **BP** and the packer **P** are connected together for run-in, an elongated tubular stinger **34** extends into bore **36** of the packer **P**. Stinger **34** has a surface **38** which supports collet heads **40** in groove **42** of the upper body **44**. Upper body **44** also has a pin **46** which extends into an indexing assembly **48** located on ratchet housing **16** (see Figures 1a and 5). Upper body **44** also has a groove **50** whose purpose will be explained below with the operation of the assembly. A spring **52**, shown in the compressed state in Figure 1a, biases lock collet member **24** downward when the collet heads **40** are liberated due to their movement away from surface **38**. In essence, when the collet heads **40** become liberated, the spring **52** pushes them into groove **50**, which puts groove **26** opposite dogs

20, thus allowing them to come out of groove 18 under the power of garter springs 22. This, in turn, allows operation of the pin 46 in the J-slot mechanism 48 to accomplish the setting of the packer P, as will be explained below.

5 Packer P also has a sealing element 54 which is ultimately set by an upward pull on top sub 56, which in turn brings the upper cone 12 under the slips 14 and thereafter pulls bottom sub 58 upwardly, bringing it closer to cone 12 and squeezing element 54 in the process. In this particular design, the set of the packer P is held by retaining an upward tensile force on top sub 56.

10 Extending from bottom sub 58 is J-pin retainer 60. Retainer 60 holds pin 62, which is operable in a series of slots 64 (see Figure 5). Slots 64 are part of J-pin latch adapter 66. Latch adapter 66 has a plurality of collet fingers 68 which terminate in collet heads 70, which during run-in are in groove 72 of ball housing 74. Ball housing 74 has an opening 76 through which extends index tab 78. Index tab 78 is a part of J-pin latch adapter 66.
15 Index tab 78 extends into groove 80 of ball shifting sleeve 82. Groove 80 is longer than index tab 78, as shown in Figure 1d. Sleeve 82 is operably connected to ball 84, shown in the open position for run-in, with its openings 86 aligned with central bore 88, which allows flow through the assembled packer P and bridge plug BP. This flow to create circulation assists in running
20 the assembly of the bridge plug BP and the packer P into the hole. At the bottom end of the assembly is choke 89 which, when flow is increased to a predetermined amount, creates backpressure in bore 88. Other devices that create backpressure in bore 88 can be used.

25 Also connected at the lower end of J-pin retainer 60 is a release probe 90. Release probe 90 has an internal shoulder 92 which retains snap latch

94. Snap latch **94** is an annular ring that rides over snap latch collet **96**. Snap latch collet **96** has an external shoulder **98** which retains snap latch **94** in view of the fact that the collet heads **100** are in contact with lower end **102** of ball housing **74**. Lower body **104** is secured to ball housing **74** at thread **106**.
5 Lower body **104** has an external shoulder **108** which defines a travel limit for snap latch collet **96**. It should be noted that the space between the lower end **102** of ball housing **74** and external shoulder **108** on lower body **104** is greater than the length of snap latch collet **96** for reasons which will be explained below.

10 Ball housing **74** has a groove **110** adjacent to groove **72** to retain collet heads **70** after the bridge plug **BP** is set, as shown in Figure 2b, for reasons which will be explained below.

The bridge plug **BP** is set by initially pressurizing bore **88** through an increase of flow through choke **89**. Pressure build-up in bore **88** results in a
15 build-up of pressure in chamber **112**, which in turn drives slip extension piston **114** under slip fingers **116**. Movement of piston **114** compresses spring **118** as the slip fingers are pushed out for initial bite into the tubing or casing (not shown). An upward pull on the lower body **104** brings up guide **120** to compress the elements **122**, as well as bringing up lower cone **124** so that its
20 taper **126** cams the slip fingers **116** outwardly against the tubing or casing (not shown).

Body lock segments **128** are held to lower body **104** by garter springs **130**. Segments **128** have a tooth profile **132** which rides on tooth profile **134** of lower body **104**, thus the segments **128** help to retain the set of the bridge

plug **BP** after a sufficient pick-up force on lower body **104** is applied with the slips **116** engaged due to pressurization in chamber **112**.

The major components of the assembly of the bridge plug **BP** and the service packer **P** now having been described, the operation will be reviewed in more detail.

In order to operate the assembly previously described, coiled or threaded tubing or drillpipe is connected to threads **10** and the bridge plug **BP** and packer **P** are lowered to the initial depth for setting of the bridge plug. While the assembly is being lowered, circulation can occur through bore **36** which is connected to bore **88**, with the openings **86** in ball **84** aligned with bore **88**. Circulation can proceed through choke **89**. When the desired depth is reached, the circulation rate is increased to increase the backpressure in bore **88**. This, in turn, drives piston **114**, which in turn wedges the slips **116** outwardly against the casing or tubing (not shown). When this occurs, an upward force is applied to lower body **104** through the coiled tubing from the surface. The applied pickup force moves taper **126** under slips **116** to further drive them into the casing or tubing (not shown). Additionally, since the slips **116** are now fixed against the casing or tubing (not shown), upward force applied to the lower body **104** brings guide **120** upwardly, compressing the sealing elements **122** against lower cone **124**. At the same time, tooth profile **134** is ratcheting past tooth profile **132** on body lock segments **128**. As a result of the upward force applied to lower body **104**, the bridge plug **BP** is set, with slips **116** firmly biting the casing or tubing (not shown) and the sealing elements **122** fully compressed.

A further upward pull forces snap latch **94** over heads **100** which are retained by ball housing **74**. It should be noted that once the bridge plug **BP** is set, an upward pull on top sub **56** is transmitted through upper body **44** through mandrel **136** to bottom sub **58**, which is in turn connected to J-pin retainer **60** and finally to release probe **90**. Shoulder **92** pushes the snap latch **94** such that it is radially expanded in order to clear the heads **100**. While a pickup force is being applied to top sub **56**, J-pin retainer **60** is also moving up so that pin **62** winds up in position **138** shown in Figure 6. When this occurs, upward movement of J-pin retainer **60** takes with it J-pin latch adapter **66** and moves tab **78** to shoulder **140** of ball shifting sleeve **82**. Further upward movement of top sub **56** will shift up ball shifting sleeve **82** so that ball **84** rotates 90° to the position shown in Figure 2b, where the openings **86** are misaligned with bore **88**. This effectively closes off bore **88** with the bridge plug **BP** in the set position.

To facilitate retaining the ball shifting sleeve **82** in the position with bore **88** closed, the collet heads **70** shift from groove **72** to groove **110**, thus, due to their inward bias, effectively holding tab **78** against shoulder **140**, as shown in Figure 2b. As shown in Figure 2c, as a result of lifting snap latch **94** over heads **100**, snap latch collet **96** has fallen down against shoulder **108** such that heads **100** are no longer supported by lower end **102**. The significance of this will be explained at the retrieval portion of the description of the preferred embodiment. The bridge plug **BP** has now been fully set and the ball **84** moved to the closed position. A setdown force is now applied to top sub **56**, which advances pin **62** to position **143**, shown in Figure 6, which upward movement then allows pin **62** to move out of the slots **64** at **142**. Further

upward movement of top sub 56 will eventually allow the collet heads 40 to be pulled away from surface 38 of stinger 34. Stinger 34 which is affixed to the bridge plug BP stays put as top sub 56 continues to move up. It should be noted that as long as the collet heads 40 are locked to groove 42 by virtue of surface 38, the packer P cannot be set. Upward movement of the packer P relative to the set bridge plug BP frees up the packer P so that it can be set at a desired location. Thus, when collet heads 40 are clear of surface 38, spring 52 pushes lock collet member 24 downwardly until groove 26 is aligned with dogs 20, thus undermining support for dogs 20. The garter springs 22 move the dogs 20 radially inwardly, thus releasing ratchet housing 16 from upper body 44. The packer P is brought to its desired location and surfaces 32, which act as drag blocks under the force of springs 30, temporarily support the packer P to facilitate its setting. Thus, when the proper depth is reached for setting of packer P, a setdown force is applied, moving the pin 46 to position 145, shown in Figure 5. A pickup force is then applied, moving pin 46 along groove marked 146 in Figure 5. Since groove 146 is longer than adjacent groove 148, the mandrel 136 can come up, taking with it bottom sub 58 as well as cone 12. Taper 150 on cone 12 catches taper 152 on slips 14 to force them outwardly against the casing or tubing (not shown). Once that occurs, further upward pickup force on top sub 56 brings bottom sub 58 against the sealing element 54 to compress it against the tubing or casing (not shown). This occurs because the bottom sub 58 moves closer to cone 12, which becomes immobile when it pushes slips 14 against the casing or tubing (not shown). This final position with the packer P in the set position is illustrated in Figures 3a-d. Figure 7 shows the position of pin 46 in groove 146

while tension is held on the packer **P** to hold its set. While Figure 3d shows the J-pin retainer **60** still over the stinger **34**, those skilled in the art will appreciate that the packer **P** can be set anywhere once the pin **62** is allowed to exit the slot assembly **64** through position **142**. If rigid tubing is used, the packer **P** can also be of the type that sets or releases with rotation when used in conjunction with a bridge plug **BP** which is set without rotation. Alternatively, the packer **P** and bridge plug **BP** can both be set with some rotation.

Those skilled in the art will now appreciate some of the benefits of the assembly described. In more general terms, a bridge plug **BP** and a packer **P** can be run in the hole, particularly on coiled tubing, and set without rotation. Thus, in deviated wellbores or even horizontal wellbores where coiled tubing use is prevalent, the assembly described above can be used to isolate a zone of any predetermined length. The separation between the bridge plug **BP** and the packer **P** occurs downhole. The packer **P** is locked against setting until after the packer **P** is released from the bridge plug **BP**, with the bridge plug **BP** already in a set position. The assembly facilitates circulation during run-in by leaving bore **88** open through positioning of ball **84**. The setting of the bridge plug **BP** incorporates in it the closure of bore **88** through the 90° rotation of ball **84**. Thus, when the packer **P** is disconnected from the bridge plug **BP**, the bridge plug **BP** is set in the casing or tubing (not shown) in a sealing manner, with the internal passage **88** closed off by virtue of ball **84**. The packer **P** can then be set in any desired position and will not set until it is separated from the stinger **34**, raised to its proper position, lowered and raised again so that it can be held in the set position shown in Figure 3 under an applied tensile load. Those skilled in the art will appreciate that although the

packer **P** has been shown to be a tension-set packer, it can also be compression-set or hydraulically set as an inflatable. The bridge plug **BP** has been illustrated as being set by a combination of fluid pressure and a longitudinal force. However, other types of bridge plugs are within the scope of the invention, particularly when they can be set without rotation. Other types of tools can also be used instead of a packer **P** or bridge plug **BP**. Anchors, which don't seal, or a whipstock are just a few examples.

As previously stated, the assembly of the bridge plug **BP** and the packer **P** can be redeployed without tripping out of the wellbore. Leading up to redeployment is the procedure to release the packer **P** and reconnect it to the bridge plug **BP** just before releasing the bridge plug **BP**. When all that occurs, the run-in position of Figure 1 is reobtained and the whole process can be repeated as many times as necessary. Accordingly, when the formation treatment through the coiled tubing (not shown) between the elements **54** and **122** is completed, it is desirable to release the set of the packer **54**. A setdown force is applied to top sub **56**, moving the pin **46** to the position **144** shown in Figure 8. As the packer **P** is lowered to contact the bridge plug **BP**, shoulder **154** on stinger **34** eventually contacts the collet heads **40** (see Figure 3d). Shoulder **154** pushes the collet heads **40**, which are at this time located in groove **50**, against the force of spring **52**. Previously, spring **52** had been holding groove **26** adjacent the dogs **20** so that they can stay in the retracted position illustrated in Figure 3a. However, when the shoulder **154** on the stinger **34** pushes the collet heads **40** into groove **42**, the top sub **56** has landed on ratchet housing **16**, putting groove **18** opposite dogs **20**. Therefore, as the collet heads **40** are displaced by shoulder **154**, groove **26** forces dogs

20 outwardly into groove 18, such that the position shown in Figure 4a is assumed.

At this time, further setdown force on top sub 56 brings the BP pin 62 into position 142 of the ratchet shown in Figure 5. At this time the snap latch
5 collet 96 is against shoulder 108, allowing the heads 100 to flex radially inwardly into recess 156 as the snap latch 94 is pushed over the collet heads 100. The packer P is now secured to the bridge plug BP. While this is happening, the J-pin latch adapter 66 is pushed downwardly, pushing tab 78 away from shoulder 140 in groove 80. As this occurs, the collet heads 70 are
10 forced from groove 110 into groove 72 (see Figure 4d). The downward shifting of tab 78 moves ball shifting sleeve 82 downwardly to rotate ball 84 into the open position shown in Figure 4d. At this time the bridge plug BP is still set but differential pressure has now been equalized through the rotation of ball 84. At this time a pickup force is applied which advances pin 62 to
15 position 160 shown in Figure 9. The snap latch 94 shoulders against the collet heads 100. The bridge plug BP can then be released by a setdown force on top sub 56 which moves the pin 62 to position 158 shown in Figure 9. The lower end 160 of the release probe 90 (see Figure 4d) gets under body lock segments 128 and pushes them upwardly so as to disengage tooth
20 profiles 132 and 134. A further downward force pulls out the lower cone 124 from under the slips 116 while extending the sealing elements 122. The bridge plug BP is now released, and the spring 118 pushes the slips 116 upwardly so that they can retract to the position shown in Figure 1e. A pickup force will reposition the pin 62 at position 156 which, in turn, brings the snap
25 latch 94 against the collet heads 100. In essence, the position of Figure 1 is

resumed, allowing the assembly to be repositioned in the wellbore for a repetition of the procedure at a different location.

5 The foregoing disclosure and description of the invention are illustrative and explanatory thereof, and various changes in the size, shape and materials, as well as in the details of the illustrated construction, may be made without departing from the spirit of the invention.

10

baker\patents\552 m&a for positioning with rotation.wpd ss

What is claimed is:

1. A method of setting a sealing device downhole, comprising:
flowing fluid through a body;
5 creating pressure in said body, said pressure causing slips
on said body to move to an engaged condition;
applying a force to said body so that said body engages a
sealing element; and
closing a valve in a bore of said body using said applied
10 force.
2. The method of claim 1, further comprising:
providing a restriction in said bore of said body to create
backpressure due to flow through said body and said valve in said body
15 when said valve is in an open position; and
moving a piston against said slips with said backpressure.
3. The method of claim 2, further comprising:
providing a latch connection between a running tool and
20 said body;
operatively connecting said running tool to said valve; and
separating said running tool from said body with a
longitudinal force which overcomes said latch connection while at the
same time closing said valve.
25
4. The method of claim 3, further comprising:
locking said sealing element in the engaged position with a
releasable lock;

setting down the running tool to reengage said latch connection to capture said body; and
opening said valve prior to release of one of said sealing element and said slips.

5

5. The method of claim 4, further comprising:
using at least a portion of said latch connection to release said slips; and
disengaging said sealing element.

10

6. A retrievable sealing device for downhole use, comprising:
a body having a bore along a longitudinal axis, said bore comprising a valve; and
slips and a sealing element on said body, said slips being
movable by backpressure created by flow through said bore to an
engaged condition, said sealing element being actuable by a force in
the direction of said longitudinal axis of said body with said slips in said
engaged condition, said valve closing as a result of said force.

15

20 7. The device of claim 6, wherein:
said bore comprises a restrictor to create backpressure;
said body comprises a latch to releasably secure said body to a running tool;
said valve being actuable by movement of a sliding sleeve
25 in said bore which is operably connected to the running tool;
said latch releasing the running tool with said sealing element actuated while said sleeve is shifted due to a longitudinal separation force on the running tool.

8. The device of claim 7, wherein:
said running tool relatches to said body with said slips set
and opens said valve when set down on said body.

5

9. The device of claim 8, wherein:
said body comprises a releasable locking member to hold
the position of said actuated sealing element;
said running tool overcoming said releasable locking
10 member after said body is relatched and said valve is opened.

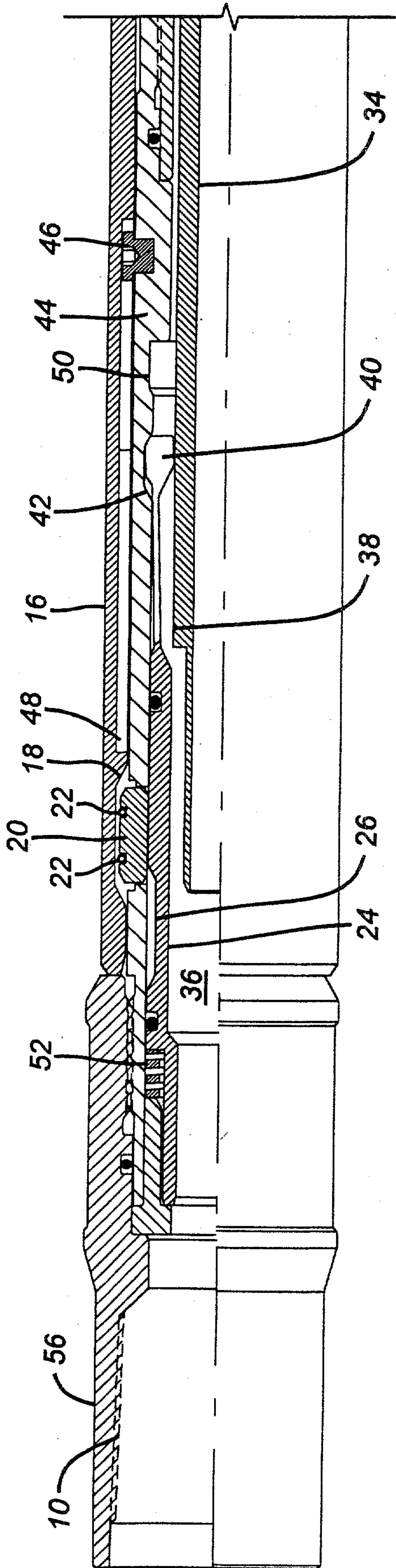

FIG. 1a

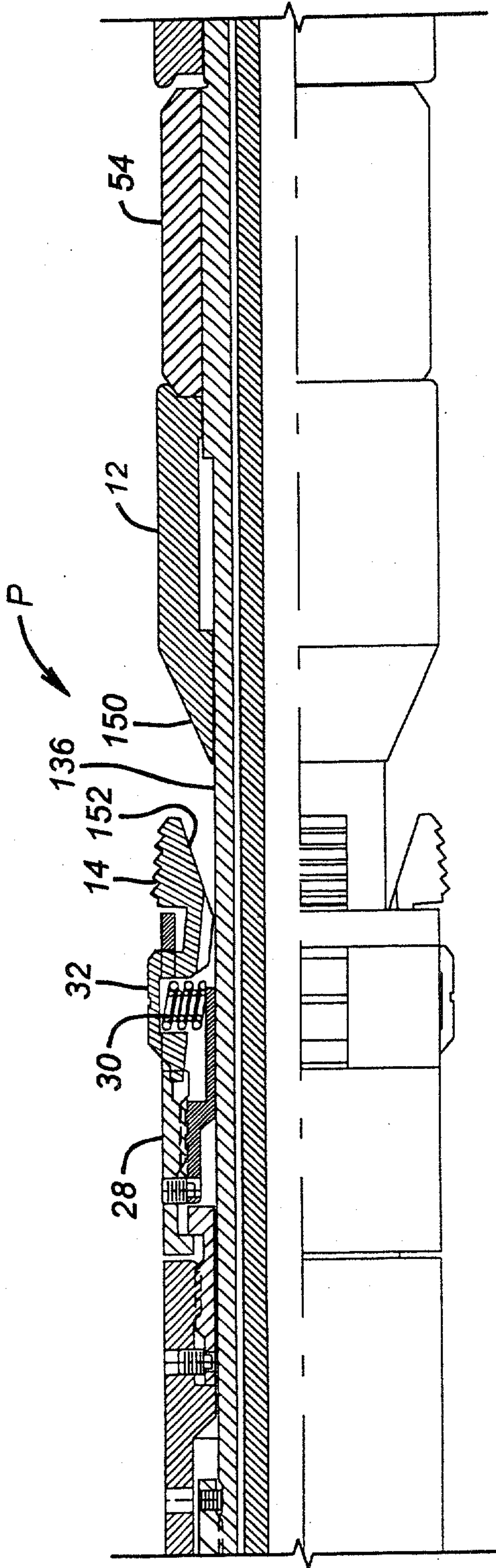

FIG. 1b

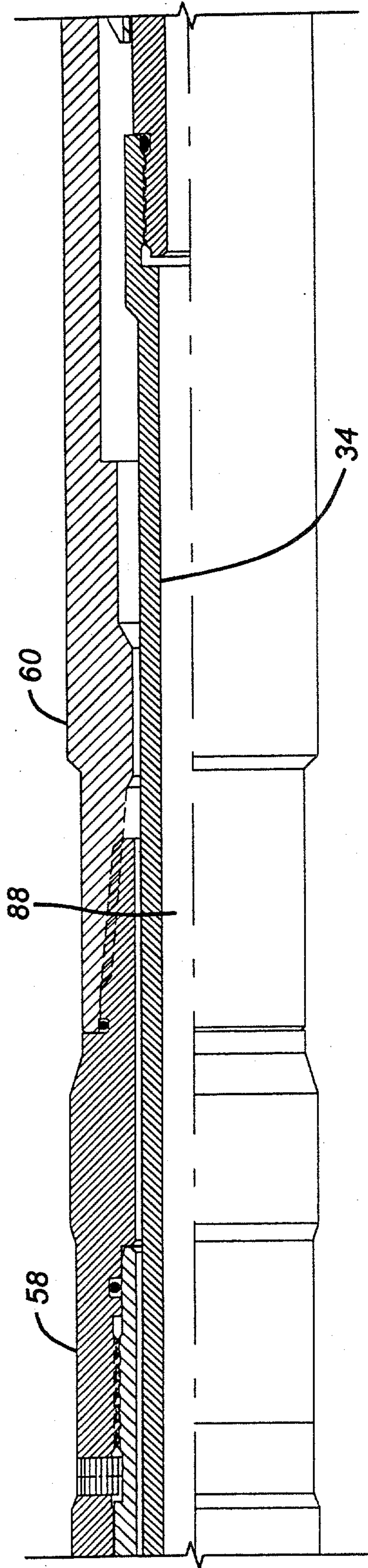

FIG. 1c

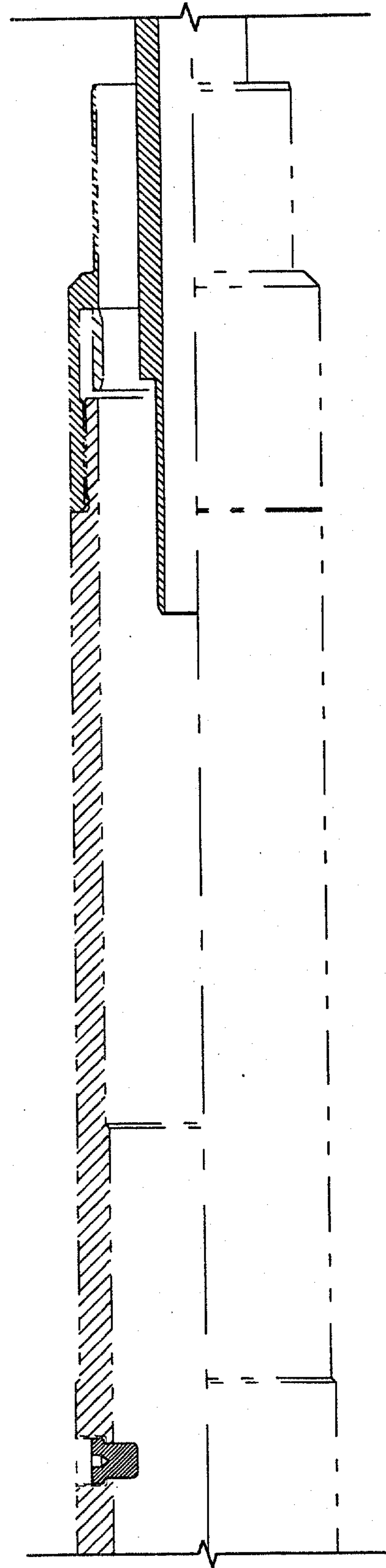

FIG. 2a

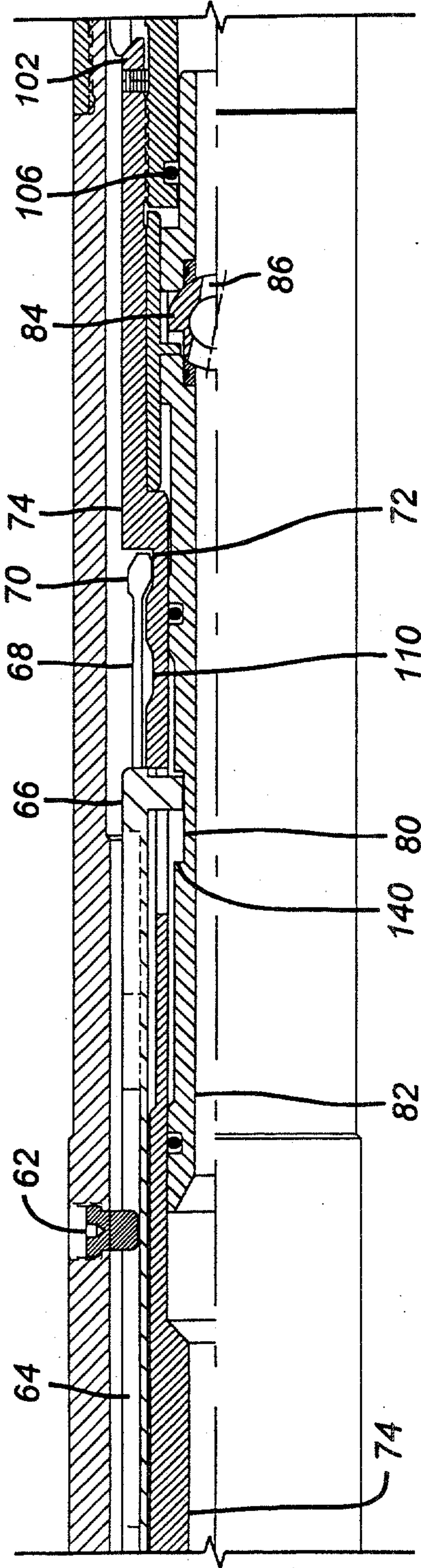

FIG. 1d

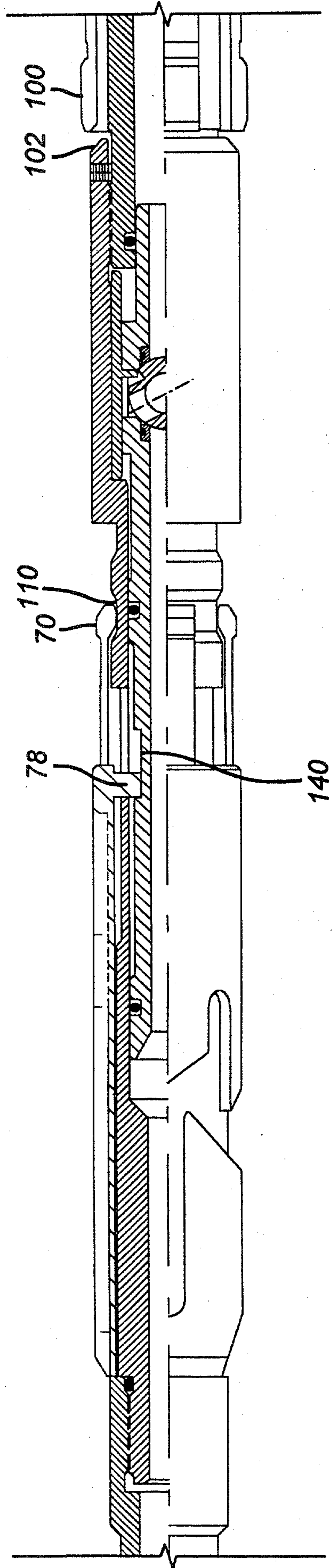

FIG. 2b

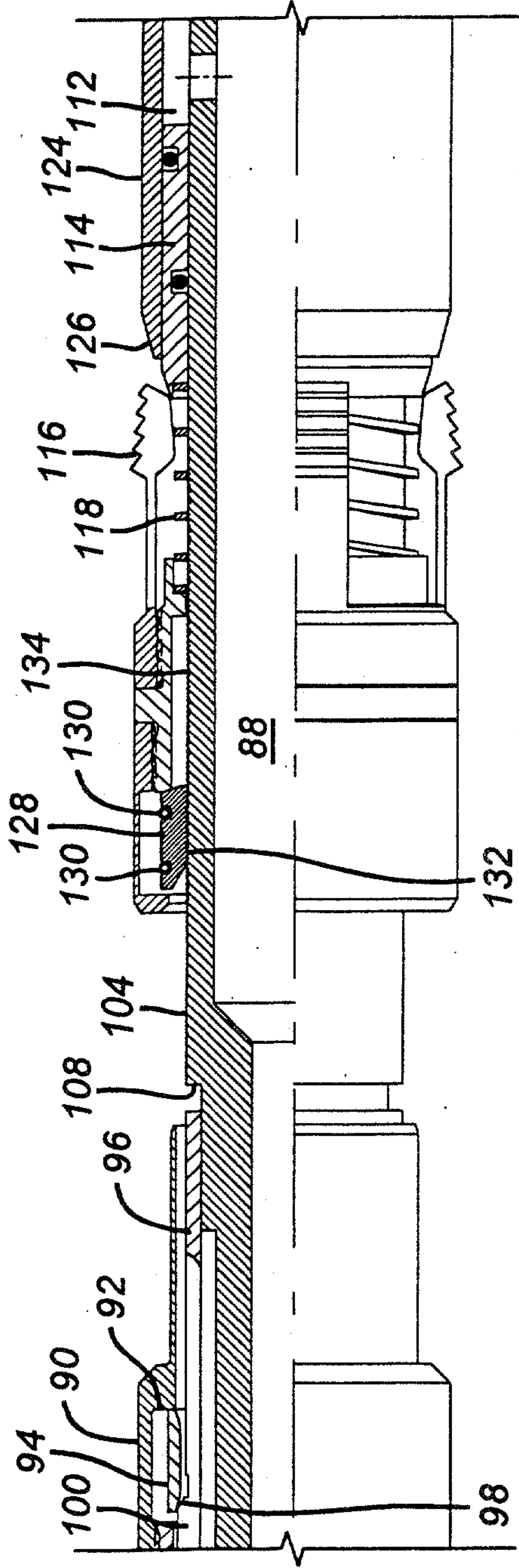

FIG. 1e

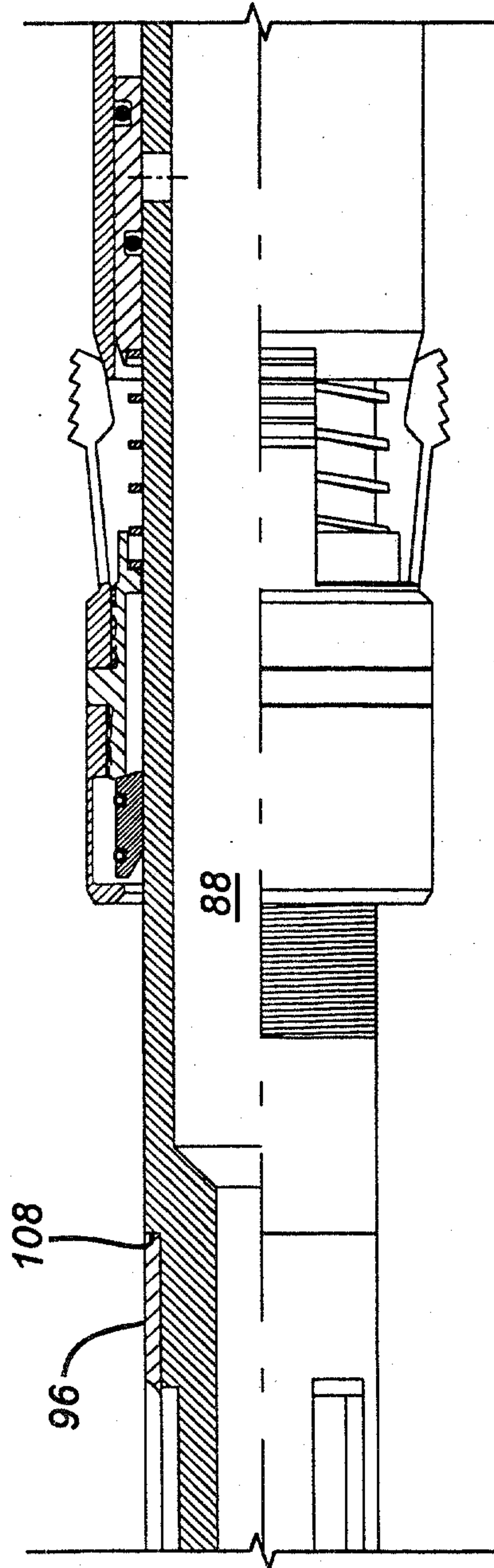

FIG. 2c

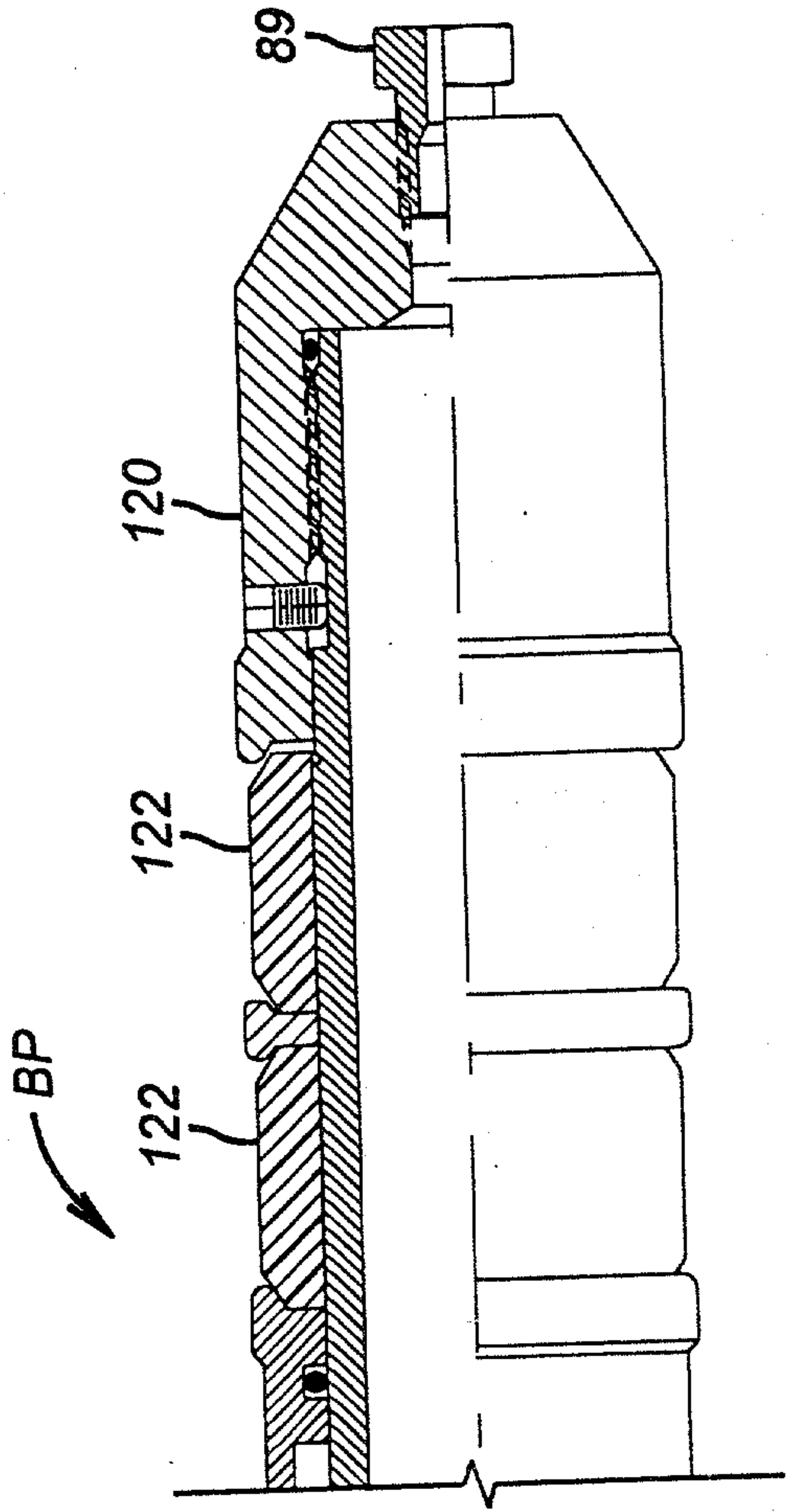

FIG. 1f

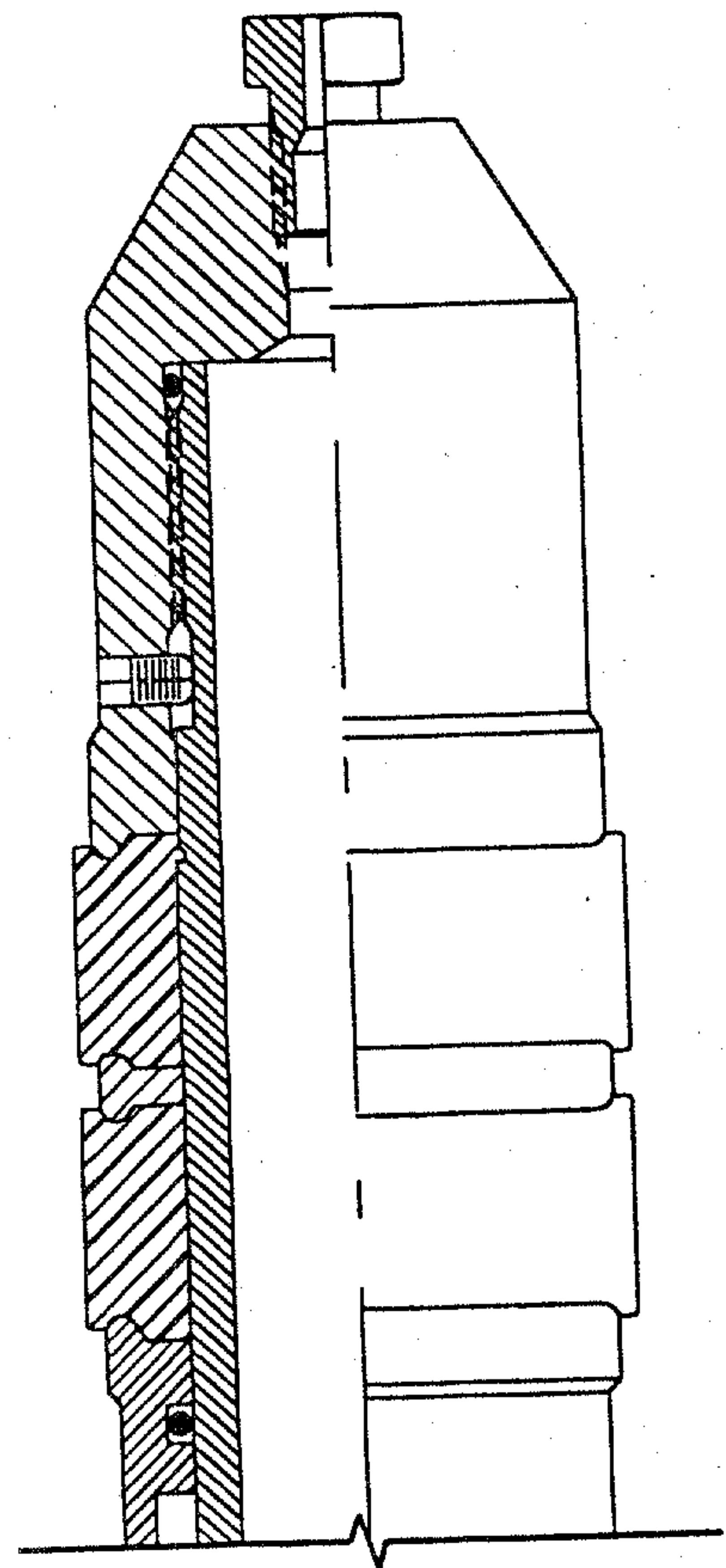

FIG. 2d

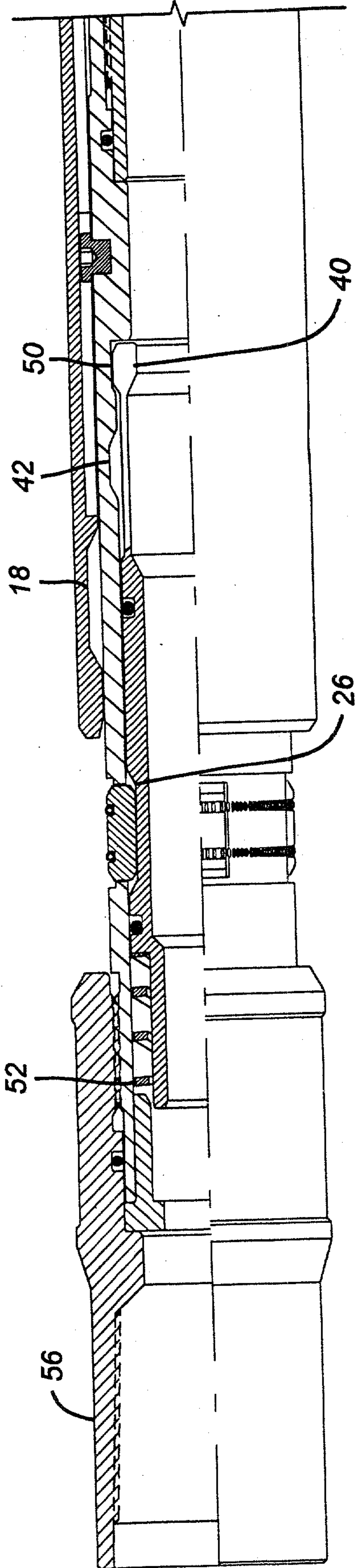

FIG. 3a

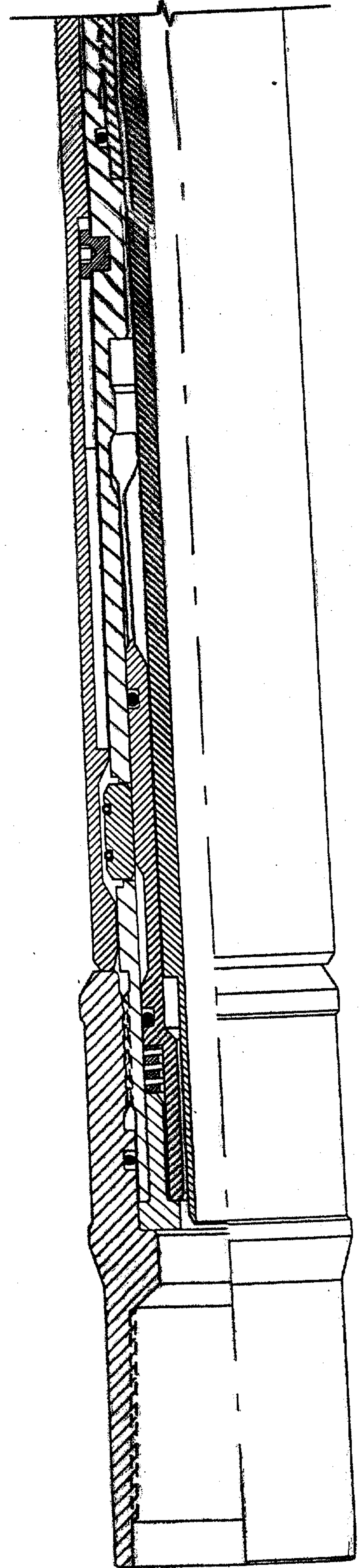

FIG. 4a

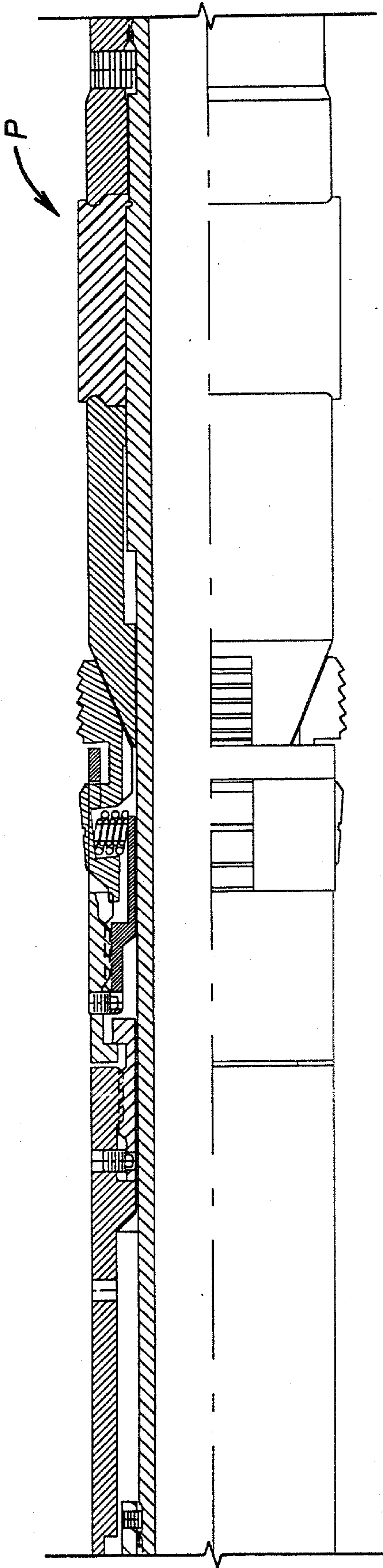

FIG. 3b

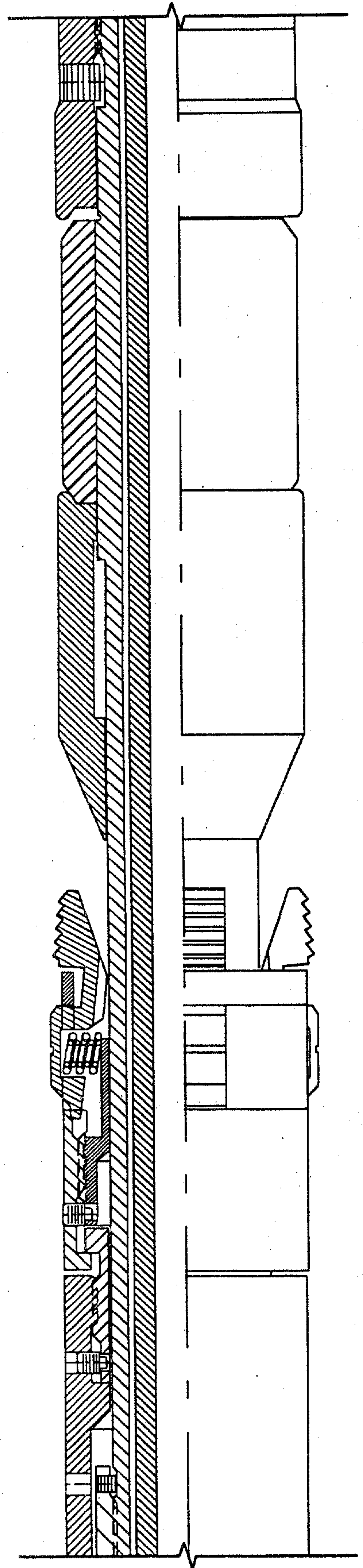

FIG. 4b

9/13

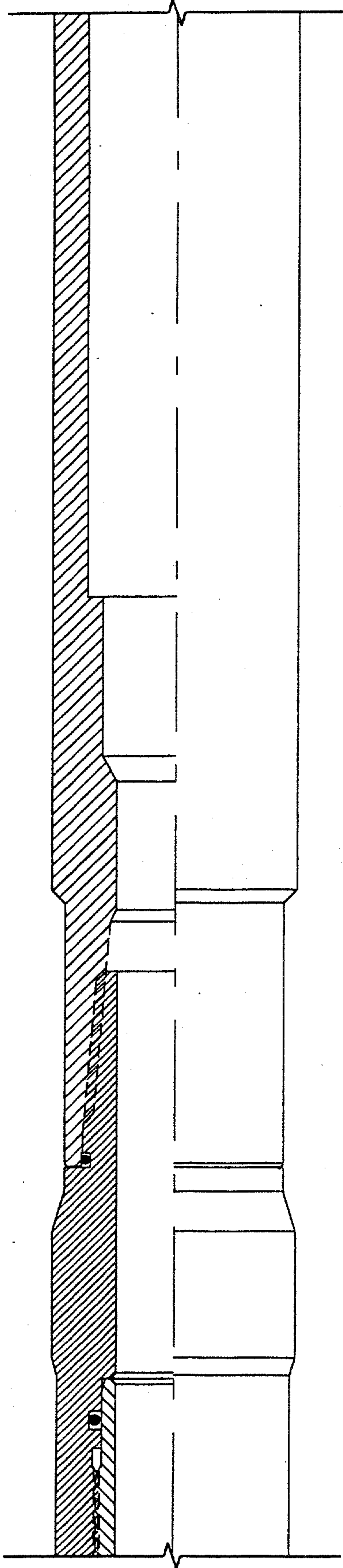

FIG. 3C

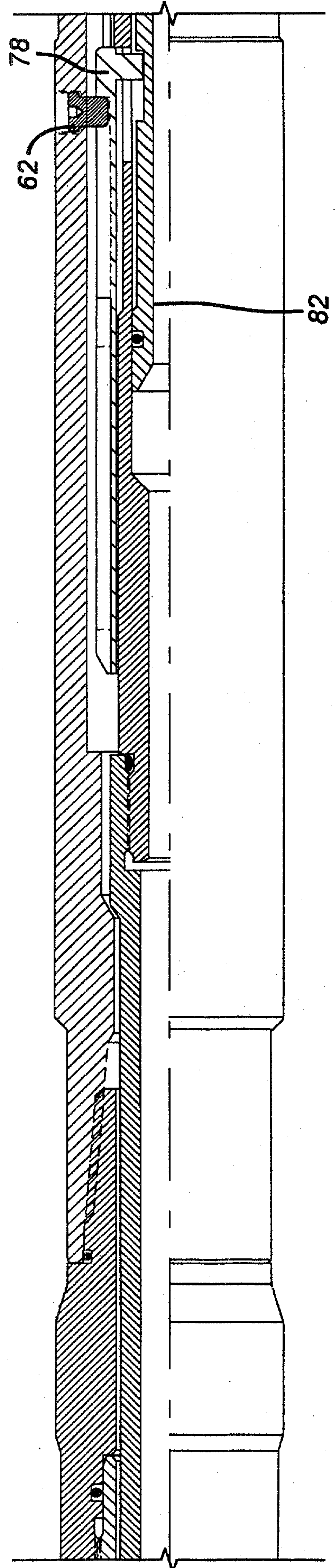

FIG. 4C

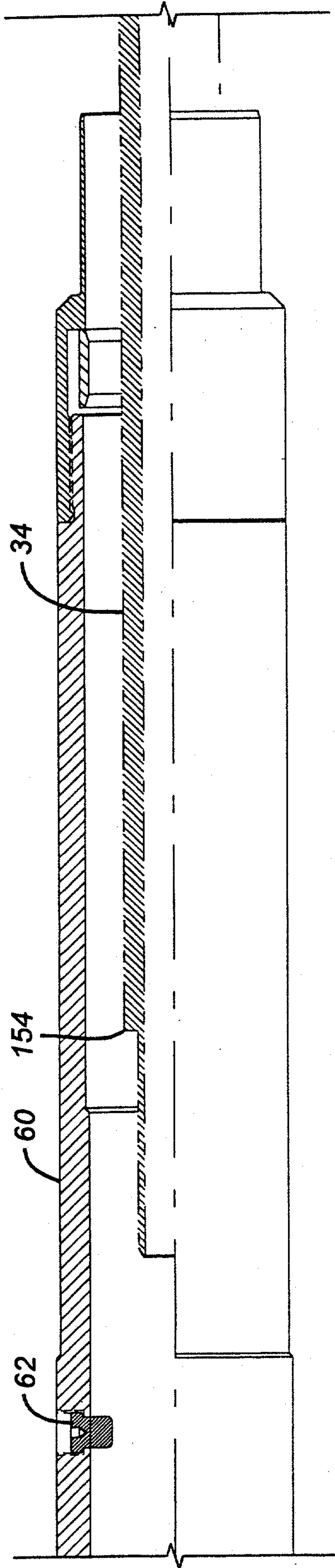

FIG. 3d

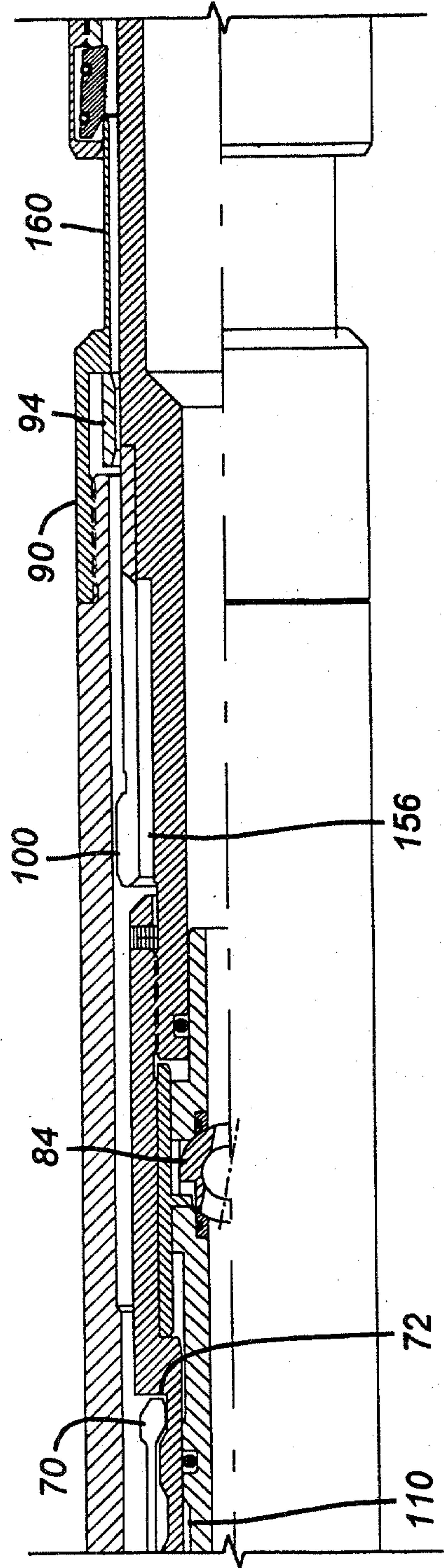

FIG. 4d

11/13

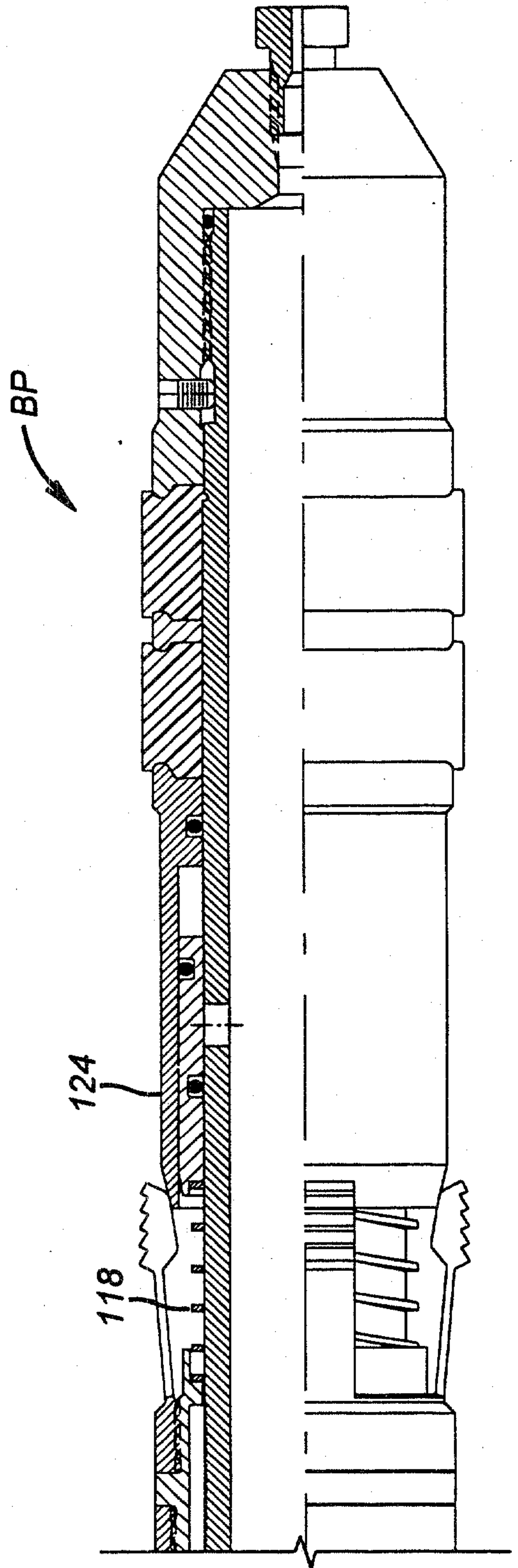

FIG. 4e

12/13

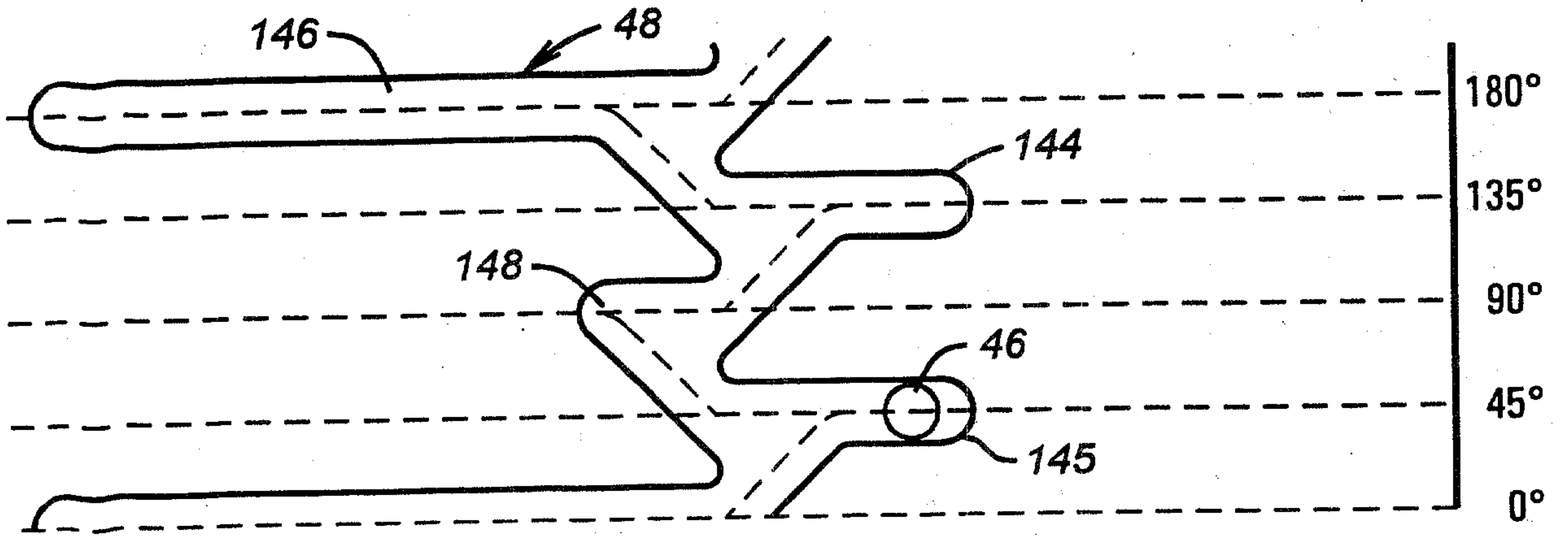

FIG. 5

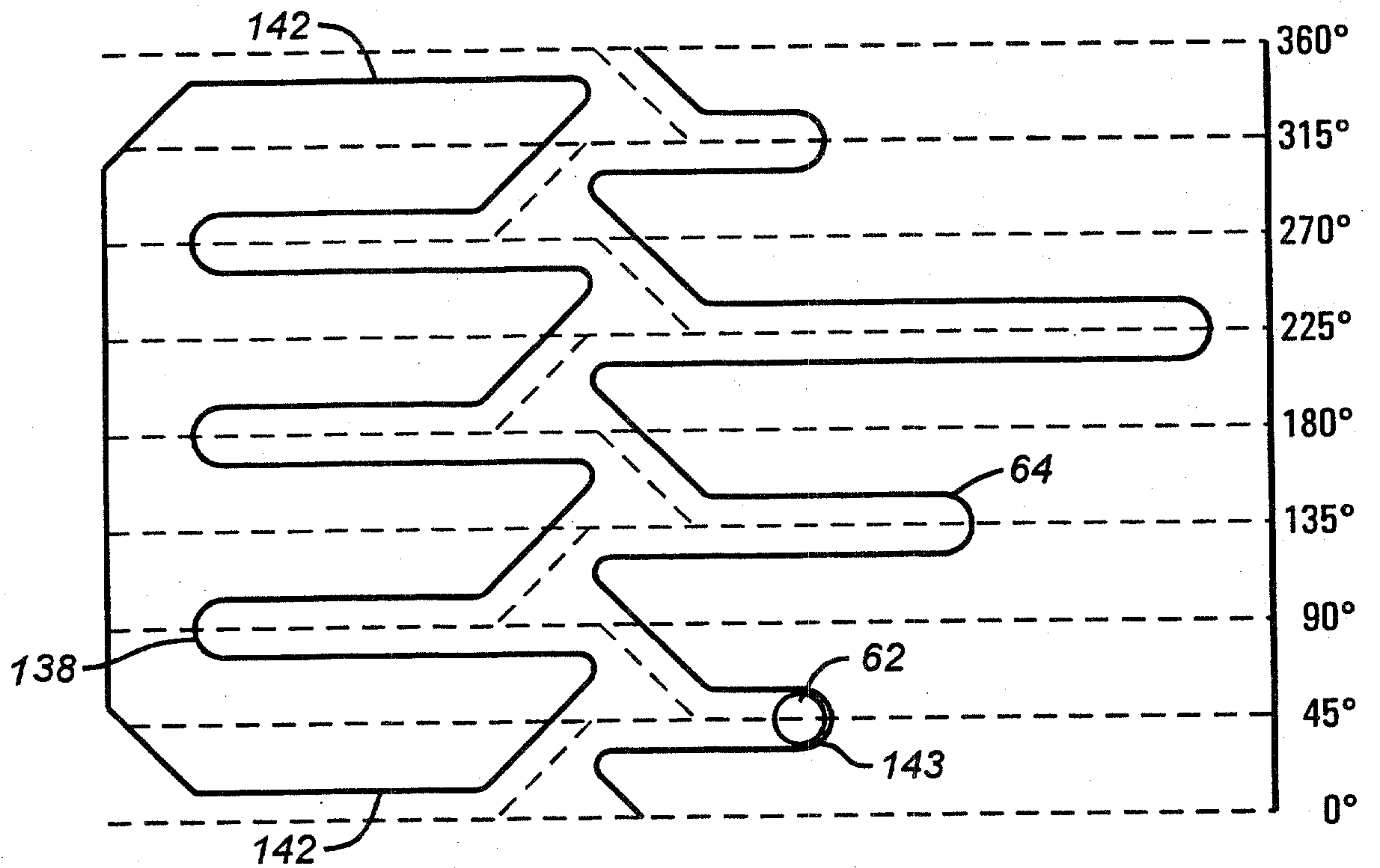

FIG. 6

13/13

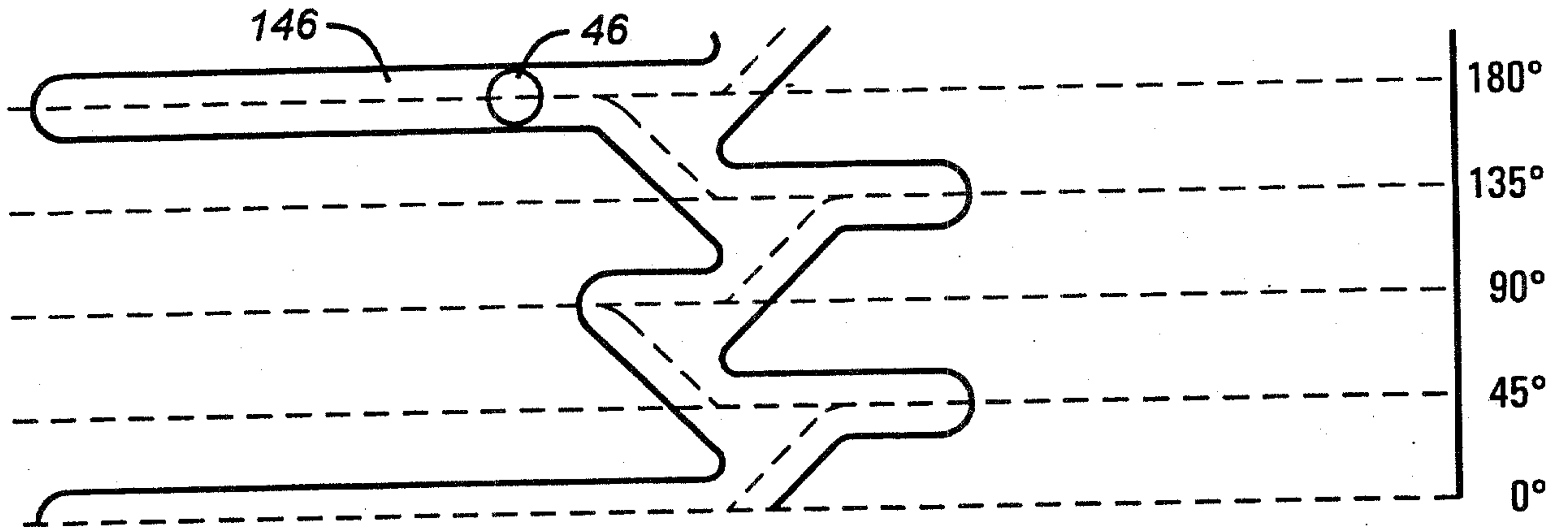

FIG. 7

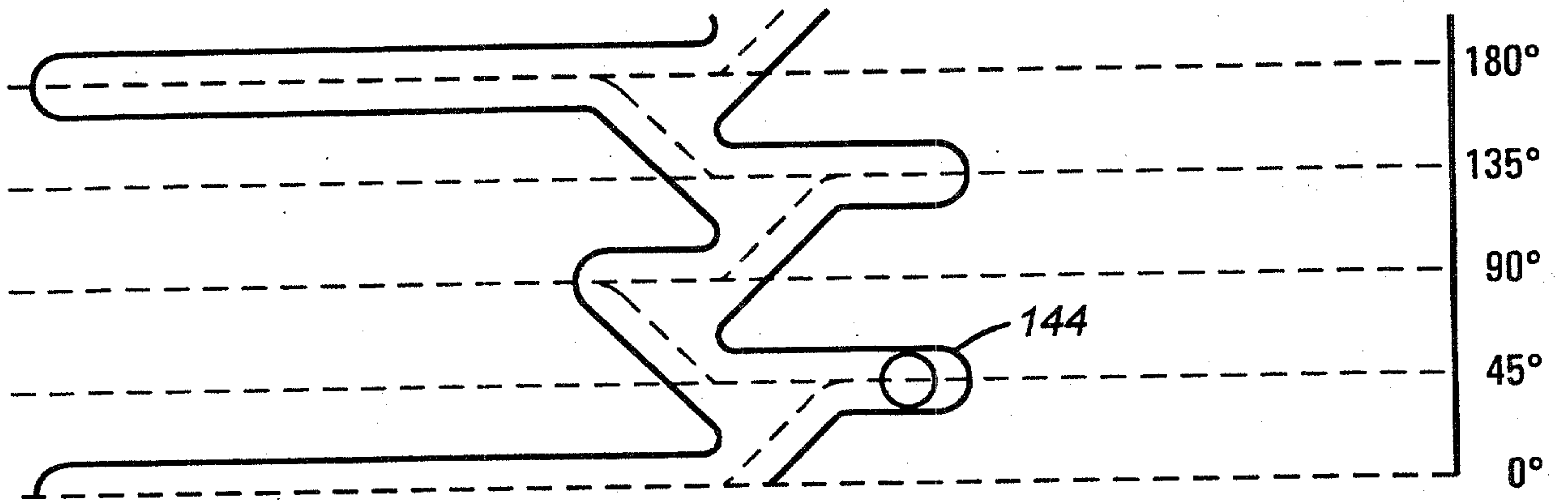

FIG. 8

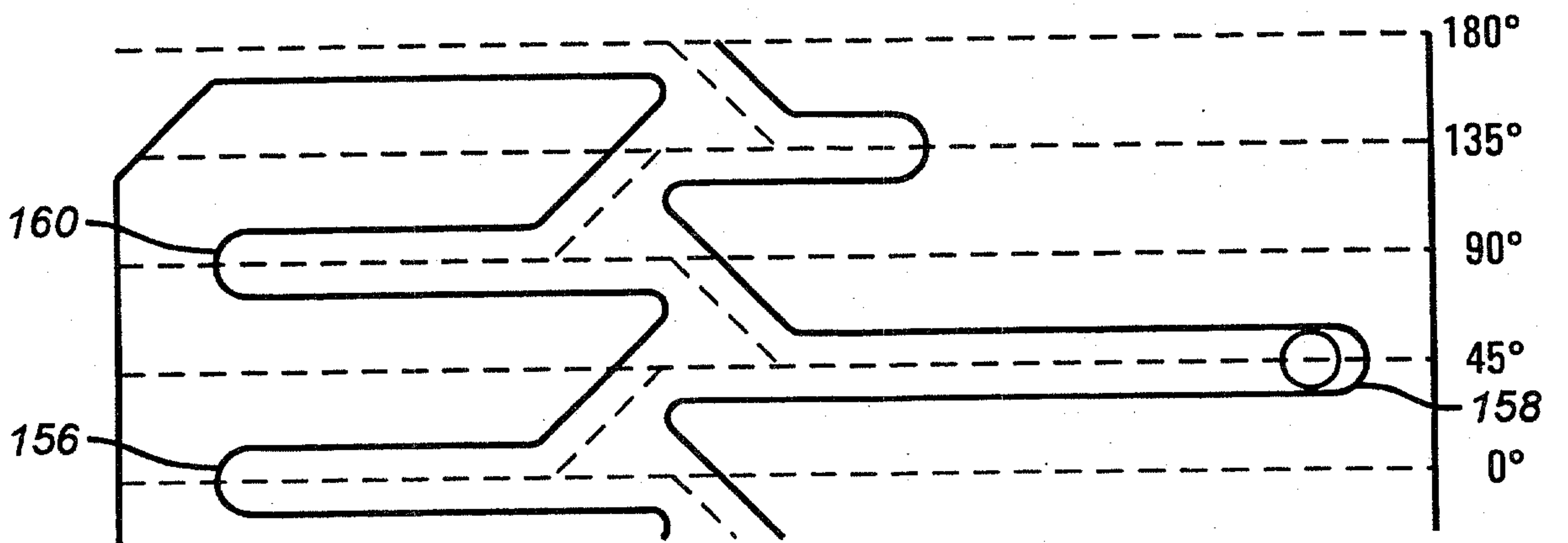
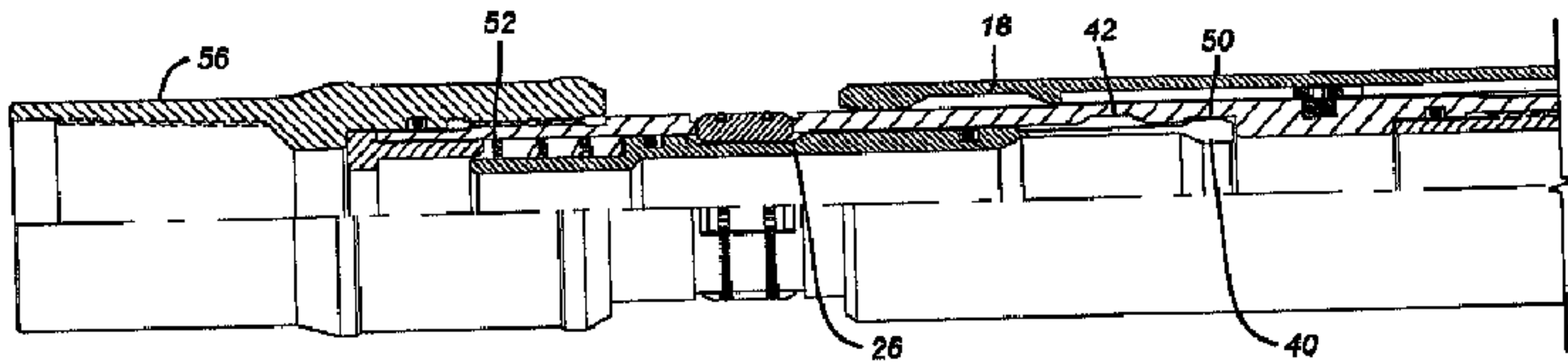
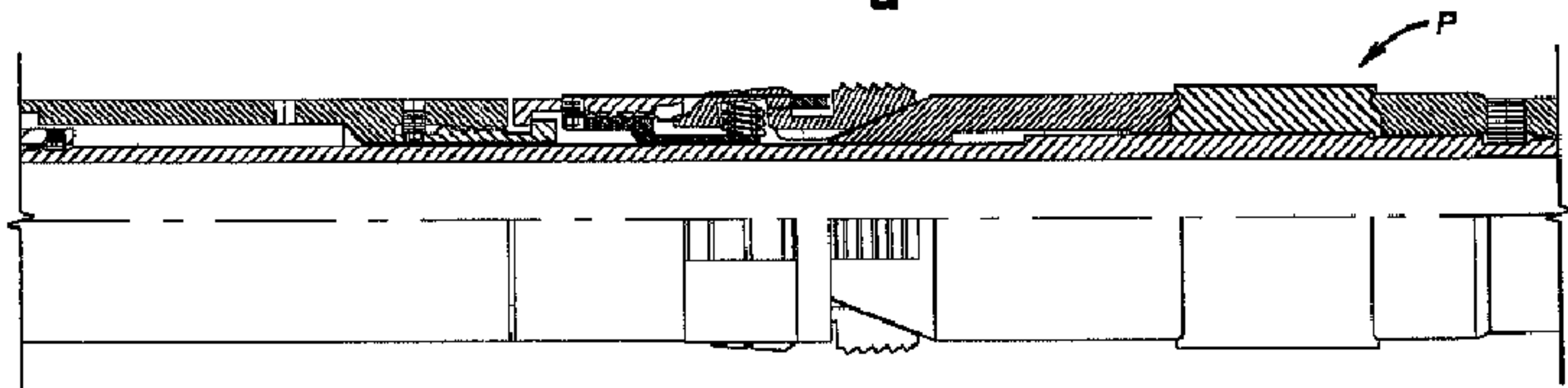

FIG. 9



a



b

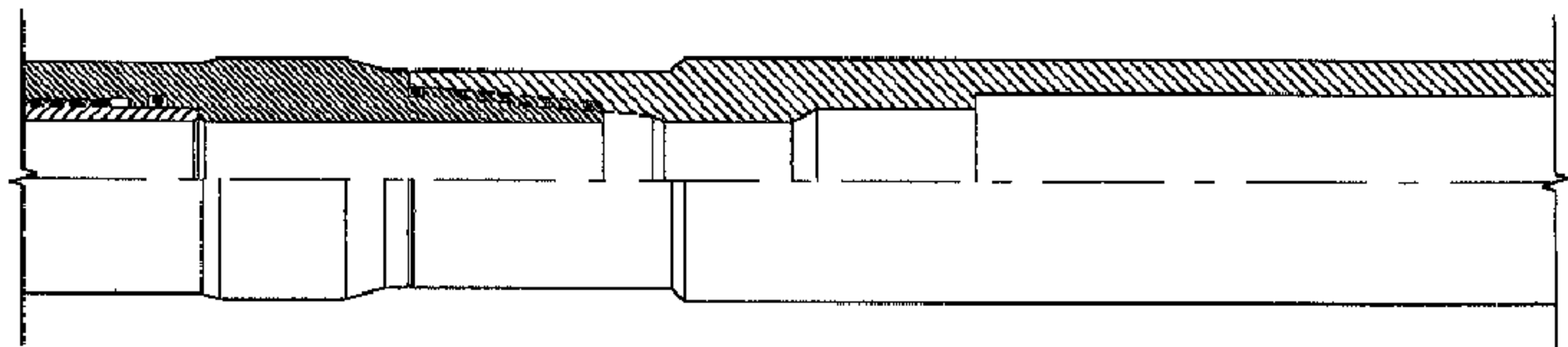

c

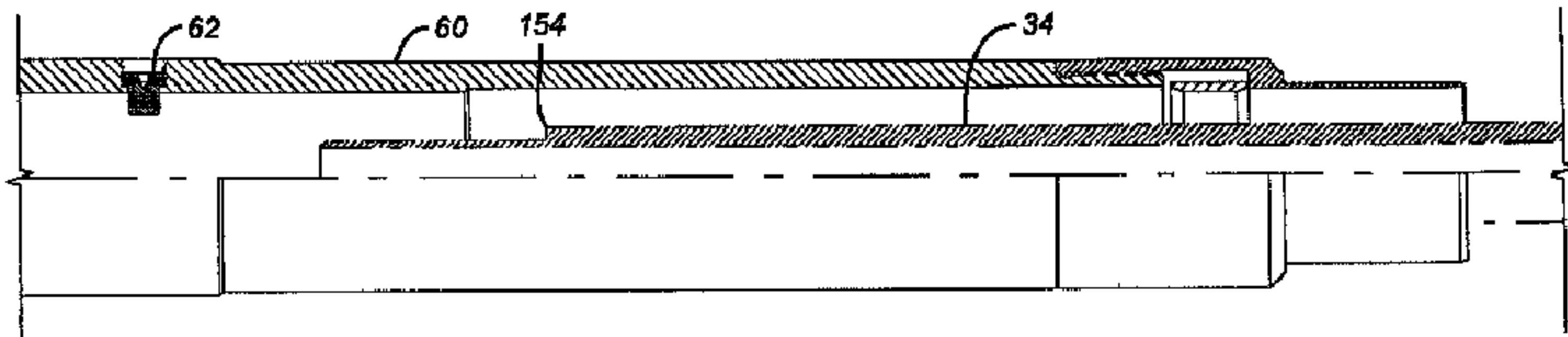

d