

3

(dazzle)

WO 97/15254, US - 5,315,099

EP - 0 550 384

1 (, LC -)

가

(viewing w

indow)

0 90 °

(nematic)

(Freedericksz)

2

1 가

1 %

0 32 Hz /

가

가 , 가

2

EN 166, EN 167, EN 169

EN 379

(T)

EN 169

가

$$N = 1 - (7/3)\log T \quad (1)$$

가

EN 379

$$I^* = (1/) (I_{1R} - I_{2R}) / I_{1L} \quad (2)$$

1R - 2R

(),

1L ().

: , LC - (spacers), LC - (scratches), 가 /

가 ; 가

(flank)

0.01 1 Hz

가

EN 169

LCD

가

(2) (1R)가 (1L)

(1R)가 ($T = 10^{(3/7)(1-N)}$)

10 50

(2R)

1 ;

2 가 ;

3 ;

4 .

가, I^* 1 . 3
 () , $1L$ 가 U , $1R$ $1L$ $1R$
 $(I^*(U))$
 $(U = U_{LC})$

- a) ;
- b) (I^*) .

(U_{LC}) . a) $U -$, (U_{LC}) $(I^*(U))$ 3 () (U_{LC})
 I^* 가 .

가

가 .

(57)

1.

(1)

(1)

(1) 2

2.

1

$(t_{s1} \ t_{s2})$

$10^3 \ 10^7$

(t_+, t_-)

3.

1

2

$(f) \ 0.01 \ 1 \text{ Hz}$ 가

4.

1

3

(1)

(1)

(U_{LC})

가 ,

(U_{LC})

(1)

$(1R)$

5.

4 ,

(U_{LC}) (1)

6.

(2) 1 (1), 1 (1) (2),
 (5) (4), (2) 1 (1)
 1 5

TN , STN , LCD

7.

6 (2) ,

(S₁) (1)가 (2).

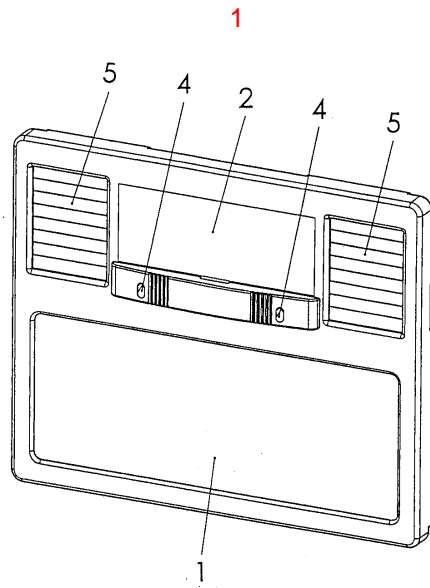

2

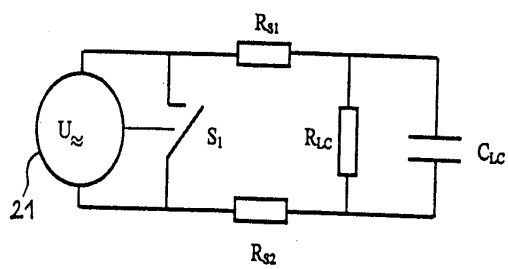

3

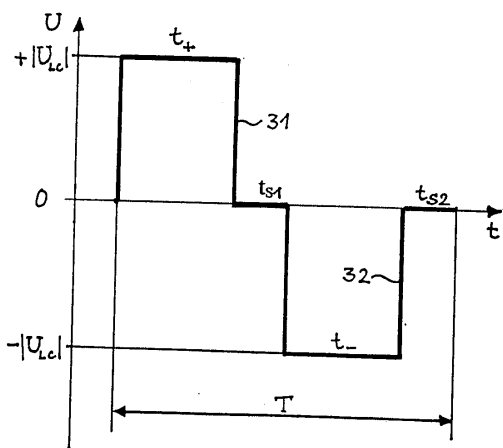

4

