

(No Model.)

A. GEIGER.
OSCILLATING PUMP.

No. 526,127.

Patented Sept. 18, 1894.

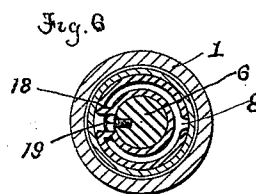
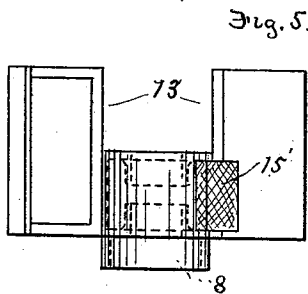
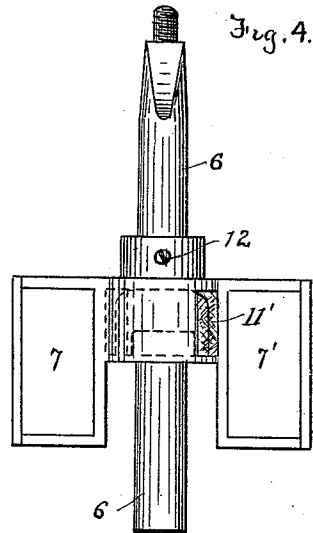
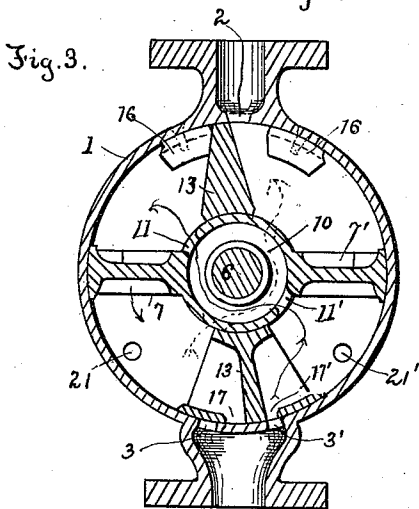
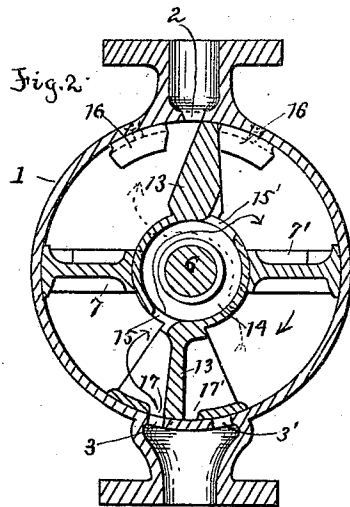
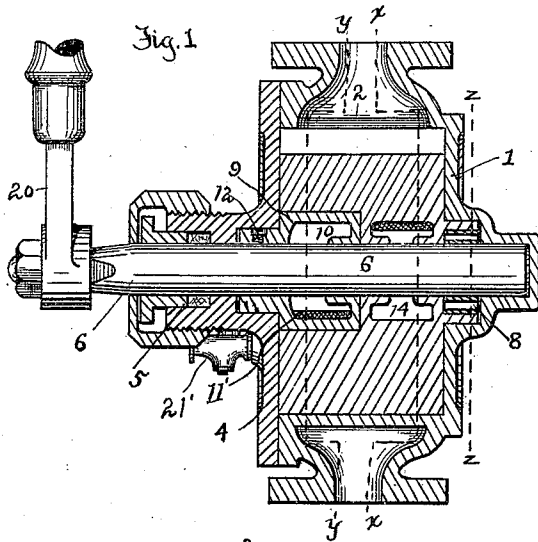

Witnesses
H. E. Bates.
Thomas Durant

Inventor
Adolph Geiger
by Churchill
his Attorney

UNITED STATES PATENT OFFICE.

ADOLPH GEIGER, OF ROCHESTER, NEW YORK.

OSCILLATING PUMP.

SPECIFICATION forming part of Letters Patent No. 526,127, dated September 18, 1894.

Application filed February 7, 1894. Serial No. 499,379. (No model.)

To all whom it may concern:

Be it known that I, ADOLPH GEIGER, of Rochester, in the county of Monroe and State of New York, have invented certain new and useful Improvements in Oscillating Pumps; and I do hereby declare the following to be a full, clear, and exact description of the same, reference being had to the accompanying drawings, forming a part of this specification, and to the reference-numerals marked thereon.

My present invention has for its object to provide an improved pump, which is simple in construction and effective in operation, requiring but few parts, and to these and other ends, it consists in certain improvements in construction and combinations of parts, all as will be hereinafter fully described and the novel features pointed out particularly in the claims at the end of this specification.

In the drawings: Figure 1 is a vertical section of a pump constructed in accordance with my invention; Fig. 2, a section of the same on the line $x-x$ of Fig. 1; Fig. 3, a similar view on the line $y-y$ showing the piston moving in the opposite direction; Fig. 4, a view of the operating piston detached; Fig. 5, a view of the valve-abutment or septum; Fig. 6, a section of the line $z-z$ of Fig. 1.

Similar reference numerals in the several figures indicate similar parts.

The casing or support of my improved pump is preferably constructed of a casting 1 having the central annular chamber, on one side of which is located a port or passage 2 communicating with the discharge, and nearly opposite, two inlet ports 3, 3', with which the supply pipe to the pump communicates; suitable flanges being formed on the ends of the casing for the attachment of the supply and discharge pipes, as will be understood. One face of the annular chamber is covered by a cover-plate 4 having a suitable stuffing box and gland 5 through which passes the operating-oscillating shaft or spindle 6 carrying the piston. Secured to the spindle 6 is the piston consisting, in the present instance, and preferably, of two wings or blades 7, 7', and a connecting hub 9 provided with an interior chamber 10, which communicates with opposite sides of the blades or wings of the piston by means of the passages 11, 11'. The pis-

ton is secured to the spindle by a screw 12, or other suitable connecting means and the hub is preferably of about half the width of the wings, as shown particularly in Fig. 4. Mounted loosely upon the spindle is an oscillatory abutment or septum 13 having an annular chamber 14 in the hub, provided with openings 15, 15', arranged on opposite sides and opposite the openings 11, 11', formed in the hub of the piston. The wings of the piston extend over the recessed hub of the abutment and are fitted thereon by a practically water-tight joint and also the ends of the piston wings are fitted by a ground or packed joint with the walls of the casing and the wings of the abutment fit in a corresponding manner upon the recessed hub of the piston forming a practically water-tight joint; the upper end of the septum or abutment being adapted to engage with suitable stops 16, as shown in Fig. 2, to limit the motion thereof, while the lower end is provided with a segmental surface corresponding to the interior of the chamber or casing having two ports 17, 17', therein co-operating with the ports 3, or 3' respectively in the casing. In order that the valve which in the present instance is constructed integral with the septum or abutment, may be shifted when the piston begins its oscillation, I extend the hub of said abutment, forming the annular chamber 8 in which operates a suitable spring 18 mounted upon the spindle 6 and prevented from independent rotation by means of a screw 19 or similar device, as shown in Fig. 6, said spring being slightly compressed when it is inserted so as to exert friction on the septum and cause it to move in the direction in which the spindle is moved, though permitting the independent motion of the said spindle after the valve or septum has been actuated a suitable distance and arrested.

A suitable handle 20 being applied to the end of the spindle 6 and the lower end of the casing connected to a suitable water supply or reservoir, the operation will be as follows: As soon as the piston is started in the direction indicated by the arrow Fig. 2, the friction spring 18 between the spindle and the valve-abutment causes the latter to be shifted to the position shown in Fig. 2, opening the port 3 and causing the water from the supply

pipe to be drawn into and fill the chamber to the left below the wing 7, the downward movement of the other piston wing 7' also causing the water to pass into the annular chamber 14 and into the chamber above the piston 7' on the right side. At the same time the water remaining below said last mentioned piston 7' will be forced through the passage 11' into the annular chamber 10 and out above the piston wing 7 on the left, thence through the exit passage 2 to the discharge of the pump. As soon as the oscillation of the piston is arrested by the stop 16 or otherwise, and the motion of the spindle reversed, the friction spring 18 will cause the valve septum 13 to first move over to the position shown in Fig. 3 thereby opening the port 3' in the casing through the port 17' causing the water to enter the chamber below the piston 7' at the right and pass thence into the upper chamber at the left, filling said two chambers and forcing the water in the lower chamber on the left through the passages 15 and chamber 14 in the septum-hub and also the water in the chamber above the piston 7' out through the exit passage 2 which is now opened. These operations being repeated as often as the piston is oscillated, filling and discharging the chambers on opposite sides of the piston at each oscillation of the latter, and shifting the valve to cause the movement of the water in the proper direction each time the movement of the piston is reversed. This construction will cause a practically continuous flow of a stream from the discharge end of the pump if the piston be oscillated rapidly and the means provided for positively operating the valve at each reversal of the movement of the piston obviates the objection heretofore existing of opening a flap or check-valve against the pressure of the column of water above the pump, thereby requiring less power. As the joints between the relatively movable parts are ground and are found in practice to be sufficiently tight, the necessity of employing packing, which cannot well be used when pumping hot liquids, is avoided.

In order to prevent the freezing of the liquid contained in the pump and pipes, I provide on opposite sides of the septum or abutment small relief pet-cocks 21, 21', the one permitting the exit of the liquid above the pump, and the other admitting air to the column of water below it, to allow the latter to return to the reservoir or source of supply depending on the position of the septum. It will be understood that when the pump is in operation, these pet-cocks are kept closed. The valves being actuated by the piston and the draining pet-cocks arranged on opposite sides of the latter, it is not necessary to manipulate any valves to free the pump and pipes of liquid, as would be the case if check-valves of ordinary construction were employed.

Instead of locating the spring or friction

device in the chamber at the end of the valve and employing the form of spring shown, the construction of these parts could be easily modified without departing from the spirit of my invention.

While it is preferable to make the valve and septum between the opposite sides of the piston integral, as shown, and I prefer this construction, for obvious reasons it is not absolutely necessary.

I claim as my invention—

1. In an oscillating pump, the combination with a casing having inlet and discharge ports and valves controlling them, of an oscillatory piston, and frictional connections between it and both the inlet and outlet valves for operating them by the movement of the piston, substantially as described.

2. In an oscillating pump, the combination with a casing having inlet and discharge ports, and valves for controlling said ports, a septum or abutment, and passages connecting opposite sides thereof, of an oscillatory piston having two wings and a passage connecting opposite sides of said wings, and connections between the piston and valves for operating the latter directly by the movement of the former, substantially as described.

3. In an oscillating pump, the combination with the casing having inlet and discharge ports, and valves for controlling said ports, of an oscillating piston and a friction spring interposed between it and the valves, whereby both of the latter are operated directly by the movement of the piston, substantially as described.

4. In an oscillating pump, the combination with the casing having inlet and discharge ports, and valves for controlling said ports, and a septum or abutment, and passages connecting opposite sides thereof, of an oscillatory piston having wings on opposite sides of the septum, a passage connecting opposite sides of the wings, and frictional connections between the piston and the valves for causing the operation of the latter, substantially as described.

5. In an oscillating pump, the combination with the casing provided with inlet and discharge ports, a movable septum or abutment having valves at its ends controlling the ports, and a passage connecting opposite sides thereof, of an oscillatory piston having wings on opposite sides of the septum, and a passage connecting the sides of said wings arranged opposite to the passage in the septum, and frictional connections between the piston and septum for causing the movement of the latter from the former, substantially as described.

6. In an oscillating pump, the combination with the casing having inlet and outlet ports, of the oscillatory piston, and its spindle, the movable septum mounted on the spindle with its ends cooperating with said inlet and outlet ports, and the friction spring arranged between the spindle and septum, substantially as described.

7. In an oscillating pump, the combination with the casing having the inlet and discharge ports, the spindle, the piston on the spindle having the wings, and a passage connecting opposite sides of the opposite wings, of the septum or abutment loosely mounted on the spindle, the ends cooperating with the ports in the casing and having the passage connecting opposite sides of the opposite ends of said septum, and the friction spring between the spindle and said septum, substantially as described.

8. In an oscillating pump, the combination with the casing having inlet and discharge ports, the spindle, the piston thereon having the broad wings and narrow hub, and the passage connecting opposite sides of the two wings, of the movable abutment controlling the ports in the casing having the narrow hub and the broad ends, and the passage extending from one side to the other, said septum being mounted on the spindle, and the friction

spring arranged between the septum and spindle, substantially as described.

9. In an oscillating pump, the combination with an oscillating piston, of an oscillating valve controlling the entrance and exit of fluid to and from the piston, and a frictional connection between said valve and piston for causing the operation of the former by the movement of the latter, substantially as described.

10. In an oscillating pump, the combination of a casing having inlet and discharge ports, the valves for controlling said ports, of a double balanced oscillatory piston, and frictional connections between it and the valve for operating the latter by the movement of the piston, substantially as described.

ADOLPH GEIGER.

Witnesses:

FRED F. CHURCH,
G. A. RODA.