

(19) World Intellectual Property Organization
International Bureau



(43) International Publication Date
28 January 2010 (28.01.2010)

(10) International Publication Number
WO 2010/011379 A1

(51) International Patent Classification:
F21V 15/00 (2006.01)

(21) International Application Number:
PCT/US2009/041124

(22) International Filing Date:
20 April 2009 (20.04.2009)

(25) Filing Language: English

(26) Publication Language: English

(30) Priority Data:
12/148,593 21 April 2008 (21.04.2008) US

(71) Applicant (for all designated States except US): **MULTI-SORB TECHNOLOGIES, INC.**; 325 Harlem Road, Buffalo, NY 14224 (US).

(72) Inventors; and

(75) Inventors/Applicants (for US only): **INCORVIA, Samuel, A.** [US/US]; 3655 Julie Court, North Tonawan-

da, NY 14120 (US). **POWERS, Thomas** [US/US]; 7210 Hannum Road, Mayville, NY 14757 (US). **SOLOVYOV, Stanislav, E.** [RU/US]; 12 Southwedge Drive, Getzville, NY 14068 (US).

(74) Agent: **ATKINSON, Robert, C.**; Simpson & Simpson, PLLC, 5555 Main Street, Williamsville, NY 14221 (US).

(81) Designated States (unless otherwise indicated, for every kind of national protection available): AE, AG, AL, AM, AO, AT, AU, AZ, BA, BB, BG, BH, BR, BW, BY, BZ, CA, CH, CN, CO, CR, CU, CZ, DE, DK, DM, DO, DZ, EC, EE, EG, ES, FI, GB, GD, GE, GH, GM, GT, HN, HR, HU, ID, IL, IN, IS, JP, KE, KG, KM, KN, KP, KR, KZ, LA, LC, LK, LR, LS, LT, LU, LY, MA, MD, ME, MG, MK, MN, MW, MX, MY, MZ, NA, NG, NI, NO, NZ, OM, PG, PH, PL, PT, RO, RS, RU, SC, SD, SE, SG, SK, SL, SM, ST, SV, SY, TJ, TM, TN, TR, TT, TZ, UA, UG, US, UZ, VC, VN, ZA, ZM, ZW.

[Continued on next page]

(54) Title: LAMP ASSEMBLY

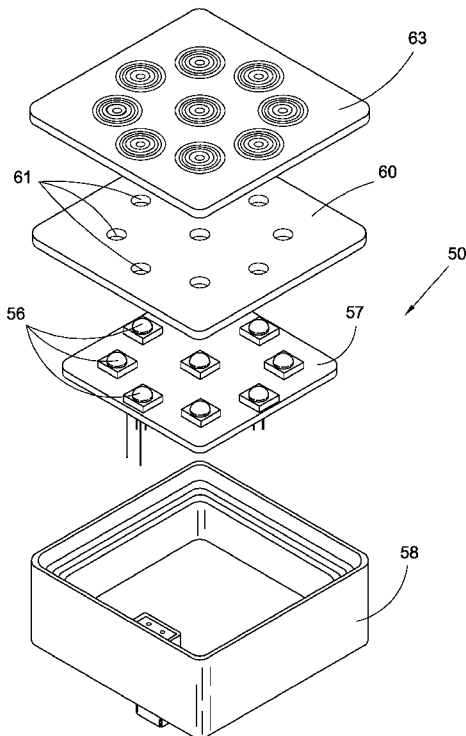

(57) Abstract: A lamp assembly including at least one light source, a housing formed from a first moisture barrier composition and a sealing cap formed from a second moisture barrier composition, wherein the at least one light source is arranged within the housing and the sealing cap is hermetically bonded to the housing and the at least one light source, and the sealing cap is arranged to enclose the at least one light source within a volume formed by the housing and the sealing cap.

Fig. 12

WO 2010/011379 A1

- (84) Designated States** (*unless otherwise indicated, for every kind of regional protection available*): ARIPO (BW, GH, GM, KE, LS, MW, MZ, NA, SD, SL, SZ, TZ, UG, ZM, ZW), Eurasian (AM, AZ, BY, KG, KZ, MD, RU, TJ, TM), European (AT, BE, BG, CH, CY, CZ, DE, DK, EE, ES, FI, FR, GB, GR, HR, HU, IE, IS, IT, LT, LU, LV, MC, MK, MT, NL, NO, PL, PT, RO, SE, SI, SK, TR), OAPI (BF, BJ, CF, CG, CI, CM, GA, GN, GQ, GW, ML, MR, NE, SN, TD, TG).
- Published:**
- *with international search report (Art. 21(3))*
 - *before the expiration of the time limit for amending the claims and to be republished in the event of receipt of amendments (Rule 48.2(h))*

LAMP ASSEMBLY

FIELD OF THE INVENTION

[0001] The present invention relates generally to articles protected by sorbents, and more particularly, to improved injection molding compositions and articles of manufacture fabricated therefrom comprising adsorbing additives in a resinous base, and even more particularly, to a lamp assembly having a moisture barrier enclosure comprising resin bonded sorbent material.

BACKGROUND OF THE INVENTION

[0002] Incorporation of sorbents, *e.g.*, desiccants, into resin matrices has been revealed in several contexts. Formation of these resins into structural or functional shapes by various processes has been described in certain applications. Similarly, fillers have been added to structural molding resins. Low cost mineral or other fillers have been added to resin-containing compositions to extend the resin and reduce costs, while maintaining strength sufficient for the intended end-use application of the molded article. It is also a frequent practice to add reinforcing materials, such as glass fibers or beads to enhance mechanical properties of molding resins, *e.g.*, hardness, tensile displacement, and so on. With reinforcing additives, just as with fillers, it has been found there are ranges within which the desired effects of extending the resin or reinforcing the molded article are accomplished while maintaining satisfactory injection molding and mechanical properties.

[0003] Nevertheless, molding compositions comprising reinforcing additives have not been entirely satisfactory for a number of end-use applications. For example, a molding composition having relatively high loading levels of reinforcing additives, such as glass fibers and glass beads have the affect of limiting the loading factor of sorbent additives which may be introduced into such molding compositions for optimal adsorption performance. However, with a corresponding reduction in the loading of reinforcing additives and an increase in the loading of sorbent additives, there was also a potential for a reduction in desirable mechanical properties, such as hardness, tensile strength, and other mechanical properties.

[0004] Thus, existing resin/sorbent matrices suffer from several drawbacks. The materials are often brittle and insufficient to survive standard drop testing. Additionally, particulate material may be released from the matrices thereby degrading part performance and/or device functionality. Due to the structure of these matrices, water may be adsorbed or

absorbed at a faster rate, which in fact may be too fast for common manufacturing procedures. In other words, the ability for a part to adsorb water may be exhausted prior to its assembly in a device because environmental conditions are not controlled in the manufacturing area. Existing resin/sorbent matrices are often quite expensive to manufacture and use due to the use of exotic resin, additional processing steps and the use of multi-resin materials having phase boundaries. Additionally, existing resin/sorbent matrices may pose compatibility issues due to materials typically used as binders.

[0005] It is well known that lamp assemblies, in particular, lamp assemblies used in the automotive and marine industries, are exposed to aggressive environments under a variety of conditions. For example, tractor trailers typically include a plurality of lamps about the base of the trailer as well as about the tractor portion. As tractor trailers carry goods in a variety of environments, *e.g.*, from the cold winters of high latitude regions to the humid summer heat of equatorial regions, lamp assemblies experience a wide range of temperature as well as ambient relative humidity. While in marine applications, *e.g.*, runner and indicator lamps, lamp assemblies may be exposed to fluids such as salt water.

[0006] In addition to the environmental factors, lamp assemblies are exposed to harsh cleaning solutions. For example, tractors are cleaned with a variety of solutions, while trailers may be cleaned with even more aggressive solutions as the trailers may be used to carry items which are difficult to remove. Similarly, it is common to use acidic solutions such as a 50/50 blend of muratic acid and water to clean boat hulls, thereby exposing the lamp assemblies to extremely aggressive solutions.

[0007] In view of the foregoing, it should be appreciated that internal electronic components of lamp assemblies are exposed to a variety of environmental conditions which degrade their performance and useful life. For example, lamp assemblies commonly include light emitting diodes (LEDs) as light sources, and these LEDs require driving circuitry and electrical connections in order to function properly. The above described environmental conditions, in particular elevated relative humidity levels, have detrimental effects on the electronics of the lamp assemblies due to moisture ingress through the thermoplastic housing, the lens covers, and wiring harnesses and connector entry points. Compounding the problem is that the thermoplastic or thermoset polymers most commonly used for these types of applications are extremely poor moisture barriers and are primarily selected for these types of applications because of their dimensional stability or ability to be bonded together to form the assemblies. Heretofore, the ingress of contaminates have been slowed through the use of

epoxy fillers, potting materials, and designed in gaskets or seals. Thus, preventing the exposure of the electronics to humidity is important, although heretofore has required expensive and labor intensive solutions.

[0008] For example, United States Patent No. 5,632,551 entitled "LED Vehicle Lamp Assembly" teaches hermetically sealing a lamp assembly by introducing an epoxy resin over the entire circuit board thereby protecting the LEDs and circuit board from vibration, fatigue, moisture and the like. Arrangements of this type are expensive to manufacture, time consuming, labor intensive and use materials that are not environmentally friendly, and in some instance may require the use of special protective equipment, *e.g.*, ventilator systems.

[0009] As can be derived from the variety of devices and methods directed at providing a hermetically sealed lamp assembly, many means have been contemplated to accomplish the desired end, *i.e.*, prevention of the ingress of moisture within the lamp assembly. Heretofore, tradeoffs between performance and cost were required. Thus, there is a long-felt need for a hermetically sealed lamp assembly which prevents the ingress of moisture therein and is cost effective and easy to manufacture.

BRIEF SUMMARY OF THE INVENTION

[0010] It is therefore a principal object of the invention to provide an improved lamp assembly which forms a moisture barrier about internally disposed electronic circuitry. It should be appreciated that the foregoing lamp assembly is advantageously formed from the resin bonded sorbent material described herein.

[0011] It has been discovered that certain sorbents, in certain resins, properly processed, have the beneficial effect of reinforcing the resin while retaining the adsorptive capacity and as a result the moisture barrier properties of the resin are enhanced. It has also been found that within limits these resins can be processed and formed by modern high-speed injection molding processes into fully functional component parts for various applications. It has been further found that the sorbent material by way of its adsorptive capacity prevents ingress of moisture into the resin and enhances the barrier properties of selective thermoplastic and thermoset polymers. Additionally, the enhanced physical and mechanical properties resulting from the sorbent material allows for the use of low cost thermoplastic and thermoset polymers that do not exhibit good molding characteristics in raw form. Moreover, the adsorptive capacity keeps the resin dry and thus enhances molding properties while eliminating the need for drying just prior to use in the injection molding process, thereby reducing processing time and cost.

[0012] At the same time it is a common and frequent practice to add reinforcing materials such as glass fibers to resins to enhance mechanical properties. With reinforcing additives just as with fillers it is found that there are ranges within which the desired effects of extending or reinforcing the resin are accomplished while maintaining satisfactory injection molding and mechanical properties. It is an object of this invention to add sorbent particles in such a way that mechanical properties such as tensile modulus and flex modulus are increased as they are with common reinforcing additives.

[0013] Certain resins are commonly considered less desirable for injection molding, olefins in particular, due to excessive shrinkage resulting in distortion of shapes and poor dimensional stability. It has been found that when certain sorbents are properly compounded so that particles are substantially fully dispersed so that substantially all particles are isolated from each other, the shrinkage of olefins is reduced to a range equivalent to resins considered good for molding such as polyamides. It is a further object of this invention to describe sorbent/polymer compounding techniques

[0014] With these things in mind, the properties of sorbents added at various proportions to molding resins were investigated.

[0015] The present invention broadly comprises a lamp assembly including at least one light source, a housing formed from a first moisture barrier composition and a sealing cap formed from a second moisture barrier composition, wherein the at least one light source is arranged within the housing and the sealing cap is hermetically bonded to the housing and the at least one light source, and the sealing cap is arranged to enclose the at least one light source within a volume formed by the housing and the sealing cap. In some embodiments, the first moisture barrier composition includes a blend of a first resin and a first sorbent and the second moisture barrier composition includes a blend of a second resin and a second sorbent. In some of these embodiments, the first resin and/or the second resin is a thermoplastic resin, while in others of these embodiments, the first resin and/or second resin are selected from the group consisting of polyamide, polyolefin, styrenic polymer, polyester and homogeneous mixtures thereof, and in some of these embodiments, the polyolefin is selected from the group consisting of high density polyethylene, low density polyethylene and polypropylene. In some embodiments, the first sorbent and/or the second sorbent are selected from the group consisting of a molecular sieve, a silica gel, an ion exchange resin, an activated alumina, a clay, a salt, a zeolite and mixtures thereof. In other embodiments, the sealing cap is hermetically bonded to the housing and the at least one light source with

welding, while in yet other embodiments, the sealing cap is hermetically bonded to the housing and the at least one light source with an adhesive or an epoxy. In some of these embodiments, the welding technique is selected from the group consisting of: sonic welding, ultrasonic welding, spin welding, hot plate welding and vibration welding. In still yet other embodiments, the sealing cap is hermetically bonded to the housing and the at least one light source by molding the sealing cap over the housing.

[0016] In yet other embodiments, the at least one light source includes at least two electrical connections and the housing includes at least two openings arranged to receive the at least two electrical connections therethrough, and wherein the at least two electrical connections and the at least two openings are hermetically encapsulated by a third moisture barrier composition. In some embodiments, the third moisture barrier composition includes a blend of a third resin and a third sorbent. In some of these embodiments, the third resin is a thermoplastic resin, while in others of these embodiments, the third resin is selected from the group consisting of polyamide, polyolefin, styrenic polymer, polyester and homogeneous mixtures thereof, and in some of these embodiments, the polyolefin is selected from the group consisting of high density polyethylene, low density polyethylene and polypropylene. In other embodiments, the third sorbent is selected from the group consisting of a molecular sieve, a silica gel, an ion exchange resin, an activated alumina, a clay, a salt, a zeolite and mixtures thereof. In still yet other embodiments, the at least two electrical connections and the at least two openings are hermetically encapsulated by the third moisture barrier composition with welding, while in other embodiments, the at least two electrical connections and the at least two openings are hermetically encapsulated by the third moisture barrier composition with an adhesive or an epoxy. In some of these embodiments, the welding technique is selected from the group consisting of: sonic welding, ultrasonic welding, spin welding, hot plate welding and vibration welding. In still yet further embodiments, the at least two electrical connections and the at least two openings are hermetically encapsulated by the third moisture barrier composition by molding the third moisture barrier composition over the at least two electrical connections and the at least two openings.

[0017] It is an object of the invention to provide a lower cost and easily produced lamp assembly by incorporating a sorbent into an injection molding resin according to the disclosure herein which maintains its adsorptive function, maintains the molding properties of the resin, enhances the mechanical properties and enhances the barrier properties to provide extended service life without elaborate seals, gaskets, fillers and potting compounds.

[0018] For purposes of this invention the expression “resin bonded sorbent”, as appearing in the specification and claims, is intended to mean a surface compatibility occurring between the sorbent and the resin through a loss of crystallinity of the resin, whereby the sorbent becomes wetted and miscible with the resin due to a reduction in surface tension. The expression “resin bonded sorbent” is intended to include binding between the resin and sorbent, which can occur, for example, through heating the sorbent with the resin, or which can be bound through suitable, non-contaminating coupling, surfactant or compatibilizing agents, discussed in greater detail below. Additionally, the term “resin” as used in blends of resin/sorbent material means the resin in the matrix, whereas “sorbent” means the material actually adsorbing or absorbing contaminants which may itself be a polymeric or resinous material.

BRIEF DESCRIPTION OF THE DRAWINGS

[0019] The features of the invention believed to be novel and the elements characteristic of the invention are set forth with particularity in the appended claims. The figures are for illustration purposes only and are not necessarily drawn to scale. The invention itself, however, both as to organization and method of operation, may best be understood by reference to the detailed description which follows taken in conjunction with the accompanying drawings in which:

Figure 1 is an end view of an accumulator in accordance with the present invention;

Figure 2 is a partial cross sectional side view of an accumulator in accordance with the present invention;

Figure 3 is an exploded view of a filter/desiccant bag/aluminum fitting component of a refrigeration system in accordance with the prior art;

Figure 4 is a side view of the component of Figure 3;

Figure 5 is a one-piece filter/fitting made in accordance with the composition of the present invention;

Figure 6 is an illustration of the use of the device shown in Figure 5 along with a desiccant bag;

Figure 7 shows a cross sectional view of an embodiment of the part shown in Figure 5 in use atop a condenser;

Figure 8 illustrates a mobile refrigeration accumulator baffle portion of a refrigerant vapor/liquid separator, such as is used in the receive of an automobile air conditioning system, made in accordance with the present invention;

Figure 9 illustrates a cap portion for the separator of Figure 8;

Figure 10 shows a cross sectional view of an embodiment of the present invention;

Figure 11 is a perspective view of an embodiment of a present invention lamp assembly;

Figure 12 is an exploded view of the lamp assembly of Figure 11;

Figure 13 is a cross sectional view of the lamp assembly of Figure 11 taken generally along line **13-13** of Figure 11;

Figure 14 is a cross sectional view of the lamp assembly of Figure 11 taken generally along line **14-14** of Figure 11;

Figure 15 is a cross sectional view of another embodiment of a present invention lamp assembly; and,

Figure 16 is a perspective view of yet another embodiment of a present invention lamp assembly.

DETAILED DESCRIPTION OF THE INVENTION

[0020] As one of ordinary skill in the art appreciates, the term “fluid” is defined as an aggregate of matter in which the molecules are able to flow past each other without limit and without fracture planes forming. “Fluid” can be used to describe, for example, liquids, gases and vapors. Additionally, a salt of a CO₂ releasing anion as used herein refers to any salt that will release CO₂ vapor upon contact with an acid stronger than carbonic acid, *e.g.*, carbonates and bicarbonates. The permeability of water vapor through high density polyvinylidene chloride is herein defined as impermeable, while the permeability of water vapor through water swellable water insoluble hydroxycellulose is herein defined as substantially permeable. Water swellable water insoluble hydroxycellulose as used herein is intended to mean cellulose with sufficient hydroxy substitution to be water swellable to an extent of fifteen percent (15%), but insufficient to cause water solubility. “Vapor permeability” as used herein refers to the rate of permeability as described above, independent of the actual permeability of any vapor or gas, except water, through high density polyvinylidene chloride or water swellable water insoluble hydroxycellulose. When the term “permeable” or “impermeable” is used herein, it is intended to refer to transfer of fluid through a material either through pores therein or at a molecular level.

[0021] It would be desirable for reasons of cost and productivity to incorporate a sorbent into a resin, and in particular one suitable for injection molding, in such a way that its adsorptive properties are preserved and the molding properties of the resin are maintained

without degrading mechanical properties. Surprisingly, the novel molding compositions of the invention and parts fabricated therewith are multi-functional, beneficially combining structural, mechanical and adsorptive capabilities without requiring the usual reinforcing additives. Consequently, with the omission of reinforcing additives the novel molding compositions of the invention are further characterized by higher moisture adsorptive capacities by allowing for higher sorbent loading factors than prior adsorbent-containing molding compositions.

[0022] Serendipitously, it was discovered as a part of the present invention, that sorbents of the “resin bonded sorbent” molding compositions have the beneficial effect of imparting reinforcement to the molding compositions of the invention while retaining their moisture adsorptive capacity, but without requiring the usual and customary strengthening additives, such as glass beads, glass fiber, and the like. This allows for higher loading factors of sorbent additives for maximizing adsorptive properties of the molding composition without trade-offs occurring in terms of significantly altered mechanical properties of the molding composition.

[0023] While the present invention relates principally to the discovery that the mechanical properties of molding resins comprising sorbent additives are capable of eliminating the usual requirement specifically for reinforcement additives, such as glass beads and glass fibers, the invention also contemplates multifunctional sorbent-resin molding compositions comprising moisture adsorbing-mechanical property enhancing amounts of adsorbent in combination with reinforcing additives and resin, wherein reduced amounts of reinforcing additives can be employed than otherwise normally required for enhanced mechanical properties. That is, the invention also provides desiccant-containing molding compositions, but with reduced quantities of strength enhancing additives, such as glass fibers and glass beads. This will enhance the mechanical properties of the molding composition without the potential for degrading the strength characteristics of the molded article. More specifically, proportional ranges of sorbent, reinforcing additives and resin can be from about 5 to about 50 Wt% sorbent; from about 0 to about 15 wt% reinforcing additive and from about 45 to about 95 wt% resin. Additionally, it has been found that a resin/sorbent matrix having a blowing agent incorporated therein maintains its structural integrity while reducing material density by about 30%.

[0024] It has also been found as a part of the present invention that, within limits, the resins can be processed and formed by several techniques, including modern high-speed

injection molding processes into fully functional component parts, including parts for various sealed systems and assemblies. In these later applications, the structural and functional features of the inventive concepts are served while ambient and ingressed moisture are adsorbed to protect sensitive materials or components of systems or assemblies from degradation by moisture; *e.g.* hydrolysis or corrosion.

[0025] In accordance with the above, the present invention comprises reinforced structural resin compositions suitable for injection molding with improved mechanical properties, satisfactory melt handling properties, and substantial moisture adsorption properties. Most thermoplastic resins are suitable for use in the resin bonded adsorbent compositions of the invention, and include homopolymers and copolymers comprising two or more monomers. Representative examples include the polyamides, such as Nylon 6; Nylon 6,6; Nylon 610, and so on. Other representative examples include the polyolefins, such as high and low density polyethylenes, polypropylene; copolymers of ethylene-vinyl acetate; polystyrene; polyesters, *e.g.*, PET, to name but a few.

[0026] As previously discussed, according to one aspect of the invention, compositions of the present invention may comprise from about 5 to about 55 wt% sorbent and the balance resin, and more specifically, from about 25 to about 45 wt% sorbent with the balance resin. More preferred compositions may comprise from about 35 to about 42 wt% sorbent, such as a molecular sieve, and the balance resin. A most preferred resin bonded sorbent composition may comprise from about 60% nylon molding resin, such as Zytel® 101, commercially available from E.I. duPont, compounded with 40% molecular sieve, such as W. R. Grace 4A molecular sieve powder. The molecular sieves of the invention can have a nominal pore size of 4Å, and a particle size range of about 0.4 to about 32µ. It is to be noted, however, that other molecular sieve pore-sizes can be used as well, such as 3Å, 5Å, or 10Å, for example.

[0027] Generally, sorbents which are useful and functional in this invention are those which bond mechanically to the resin without special additives, such as molecular sieve, as previously discussed. Still others, according to the instant invention, can be induced to bond to the resin through use of a suitable additive, *i.e.*, bind with the aid of a coupling or compatibilizing agent. In addition to molecular sieve, other representative sorbents that are useful in the compositions of the invention include silica gel, activated carbon, activated alumina, clay, other natural zeolites, and combinations thereof. Those sorbents found to

perform with coupling or compatibilizing agents include such members as activated carbon and alumina.

[0028] The additives which perform as compatibilizers fall into either of two categories, namely those which bond with the resin or the sorbent, and those having some affinity with both resin and sorbent, and act as solid state surfactants. Reactive coupling agents include such classes as maleates, epoxies and silanes. More specifically, reactive coupling agents include such representative examples as maleic anhydride grafted polymers used in amounts ranging from about 2 to about 5 Wt%. In particular, they can include such representative examples as maleic anhydride grafted to polypropylene or ABS resins, the latter being useful as coupling agents with styrenic polymers. Similarly, silanes with various functional groups attached may be used.

[0029] The present invention also contemplates the use of so called non-reactive type compatibilizing agents in binding sorbent and resin. This comprises such representative examples as metals (e.g., zinc or sodium), acrylates, stearates and block copolymers, e.g., zinc stearate, sodium stearate in a range from about 0.01 to about 0.02 wt% based of the sorbent. The actual level is driven by the surface area, which is in-turn proportional to the particle size. For a molecular sieve with mean particle size of 10 μ , 100 ppm of aluminum stearate would be a typical starting level for compatibilization with a polyamide resin. With both reactive and non-reactive coupling/compatibilizing agents, their incorporation within the resin matrix does not create phase boundaries.

[0030] The resin bonded sorbent compositions may be prepared in accordance with the present invention using plastic compounding techniques generally familiar among ordinary skilled artisans. Molecular sieve, a preferred sorbent, may be incorporated into the resin, e.g., polyamide, polyolefin, or the like, by feeding the sorbent in powdered format along with beads of the chosen resin to a plastics extruder with good mixing characteristics. Although single-screw extruders may be used to compound a resin and sorbent, a resin and sorbent blend normally needs to be double-compounded in order to produce a suitable resin bonded sorbent material. Even after double compounding, phase separation sometimes occurs. It has been found that resin bonded sorbent materials compounded with twin-screw extrusion equipment with extensive back mixing is needed to attain nearly complete dispersion of the sorbent and develop the superior mechanical and physical characteristics which are an object of this invention. In other words, resin bonded sorbent materials formed via a twin-screw extruder show little or no migration of sorbent within the resin matrix and

thus these resin bonded sorbent materials maintain a homogeneous appearance. Therefore, twin-screw extruder compounding is typically used to form resin bonded sorbent materials of the present invention, as the resin is melted and the sorbent mixed throughout. It is a necessary condition that the melt blend be heated above the melt point of the resin as determined by DSC (differential scanning calorimetry). That is, in preparing the resin bonded sorbents of the invention, the temperature should be raised to the point where all crystallinity is lost in order to achieve complete miscibility of the sorbent in the resin melt. For example, DuPont's Zytel® 101 polyamide resin would be heated above 262°C. The extruded resin is cooled and then cut or crushed into pellets or granules. Because compounding is performed at elevated temperatures, the sorbent tends not to adsorb moisture during this processing period, but retains its adsorption capacity when molded into a component part and installed in a working environment.

[0031] One further advantage realized with the resin bonded sorbent system of the present invention, wherein the resin and sorbent are intimately bonded, is that gram for gram it is more effective than adsorbent systems employing a bagged adsorbent, *i.e.*, adsorbent capacity per unit volume. According to earlier methods wherein bags were used for containerizing sorbent, the sorbent required beading to prevent it from entering the refrigerant stream, for example. This required the sorbent to be bonded within a binder resin, typically 15 wt% binder, such as in the form of a powder. Thus, when 40 grams of a commercially prepared sorbent was placed into a bag, in reality only 34 grams of sorbent were introduced into the system (with 6 grams of binder). In contradistinction, the resin bonded sorbents of the present invention require no additional binder resin because the sorbent is placed directly into the molding resin from which the components are fabricated. Advantageously, with the immediate invention, no intermediary binder resin is required, allowing for higher sorbent loading factors than otherwise achieved with the usual bagged sorbents.

[0032] The compounded resin blend of the invention, previously discussed, can then be extruded into a sheet or film, or injection molded in the form of a part. An exemplary part is a refrigerant vapor liquid separator, such as is used in the receiver of an automotive air conditioning system. The strength of the silicate-reinforced resin results in a structurally sound molded part. As such, it is self-supporting and suitable for mounting in the same ways that metal or plastic refrigeration components are presently mounted. See, for example, Figs. 1 and 2, which show an end and partial cross sectional side view, respectively, of a U-Tube assembly **100**. This embodiment, which uses the composition of the present invention to

form a liner or sleeve **110** out of the resin bonded sorbent of the present invention, contains a U-tube **120** within accumulator canister **130**. This design provides a means of drying against an exposed inner surface of liner **110**. This embodiment is an alternative to a “baffle” type accumulator of the prior art (not shown).

[0033] Alternatively, the resin formed in accordance with the present invention, instead of being melted and injection molded into a functional sorbent part, may be milled or otherwise formed or pelletized into pieces which are then sintered into parts, such as a flow-through monolith structure, or a flow-through dryer component, *e.g.*, electronics filtration for a hard drive. In this case, the part is not injection molded, but is molded from the compounded sorbent-loaded resin into a functional part having sufficient porosity for its intended application, such as for use in a receiver dryer assembly.

[0034] Parts fabricated from the resin bonded sorbents of the present invention are particularly well suited to replace multiple-component parts of the prior art. For example, in the past many specialized structures have been developed to fit and secure a desiccant material (which was loose) in various parts of a refrigeration system. Welded or sewn bags containing beaded or granular molecular sieve or aluminum oxide would be disposed within a flow path. Additionally, and specifically with respect to stationary refrigeration applications, beads or granules of desiccant were bonded together in a heated mold with a suitable heat-cured resin or ceramic binder to produce a rigid shape which would serve as a drying block or partial filter. Such a structure would be built into a housing. These solutions, however, involved complicated multiple part pieces. The present invention, however, joins the performance of the desiccant with the structural purpose of a part such that a one-piece device serves both functions simultaneously.

[0035] For example, the present invention is contemplated for use with an Integrated Receiver Dehydrator Condenser, such as those which are starting to find their way into a growing number of vehicles. Such mobile refrigeration cycle components basically combine the drying function with the condenser for a number of reasons. It reduces the number of system components, therefore making better use of under-hood space, and concomitantly reduces the number of fittings and connections minimizing the potential for system leaks. It also has some performance gains relative to cooling efficiencies. The current technology is illustrated in Figs. 3 and 4 which show aluminum threaded plug **300** with O-rings **305** and **306**, an injection molded filter **310**, and desiccant bag **320**. By converting this system to a one-piece injection molded plug/filter assembly, such as that shown in Fig. 5, a one piece

plug **500** with O-ring **510** can be utilized. In such a case, plug **500** could be assembled with desiccant bag **600** as shown in Fig. 6. Fig. 7 illustrates a partial cross section of the device assembled.

[0036] More specifically, Fig. 7 shows the device **700** disposed adjacent condenser **710**. Device **700** is comprised of desiccant bag **720** disposed within receiver dryer tube **730**. On the end of device **700** is filter tube **740** housing integral threaded plug and filter **750**. O-rings **705** are also shown. Desiccant bag **720** is connected to integral threaded plug and filter **750** at interface **760**. This design would eliminate all the separate assembly steps and create a part with fewer separate pieces, as compared to the aluminum threaded plug described above.

[0037] Still another embodiment incorporating the present invention is shown in Fig. 8, which illustrates a mobile refrigeration accumulator upper portion **800** of a refrigerant vapor/liquid separator, such as is used in the receiver of an automobile air conditioning system. As can be seen in Fig. 8, accumulator upper portion **800** contains J-Tube **810** which is mounted within it. In this case, one or both of these pieces are molded from the resin bonded sorbent composition of the present invention. Fig. 9 illustrates cap **900** which would be placed over top accumulator upper portion **800**. In a preferred embodiment of such an accumulator apparatus, both upper portion **800** and cap **900** would be injection molded and then welded, or possibly injection blow-molded in halves. Completing the device would be a lower portion (not shown) which could also be molded from the resin bonded sorbent composition of the present invention.

[0038] In order to demonstrate the benefits of the resin bonded sorbents of the present invention, the following experiments were performed:

EXAMPLE 1

[0039] Test samples of resin bonded sorbents were prepared according to the claimed invention employing the following protocols. The resins are procured from a supplier in pellet form (most common is cylindrical (.03-.12 inch diameter x .06-.25 inch long), other forms included tear drop format (.06-.19 inch). The ratio of molecular sieve to the resin is determined by weight of the components. The resin was premixed in a poly bag by hand (5-15 min). The pre-blend was emptied into the hopper of a Brabender single screw extruder. Action from the screw further blends and melts the resin and molecular sieve as it travels through the extruder barrel. The resin bonded sorbent then exits through the single strand die (1 circular hole) at the end of the extruder forming one strand of molten material. The nylon based resin was heated above 262°C. The strand was then cooled by air. The strands were

broken into pieces. The pieces were placed in a hopper of an injection molding machine and parts molded. The parts were broken into pieces and re-introduced back into the injection molding machine where the tensile specimens (dog bones) were injection molded for testing. Although a single screw extruder was used in this example, as described *supra*, a twin-screw extruder may also be used to compound a resin and sorbent, and such variations are within the spirit and scope of the claimed invention.

[0040] The resin chosen was one known to be compatible with refrigerants used in modern air conditioning systems, specifically R-134a and R-152a. The resin was also compatible with compressor lubricants entrained in the refrigerant stream. The desiccant was the same as that most commonly used in conventional systems, namely a 3A or 4A molecular sieve.

[0041] For comparison, a commonly used reinforcing glass bead was compounded at about the same loading. Glass beads are added to a polymer melt to control shrinkage and to uniformly enhance mechanical properties. Glass beads were effective in this application because they bonded mechanically to the resin, so that after molding an isotropic structure resulted.

[0042] The compounded resin mechanical properties are compared with the pure polymer and with glass reinforced polymer in Table I.

Table I: Properties of Reinforced Nylon				
Property:	Material:	Nylon Neat	Molecular Sieve Reinforced Nylon	Glass Bead Reinforced Nylon
Loading (%)		0	36.6	38.2
Hardness – Shore D (ASTM D 2440)		81.4	93	86.6
Tensile Modulus (psi) (ASTM D 638)		203779	307252	361470
Tensile Displacement @ Max Load (in.) (ASTM D 638)		0.62	0.144	0.132
Tensile Stress @ Max. Load (psi) (ASTM D 638)		10907	10519	10412
Flex Modulus (psi) (ASTM D 790)		336577	439087	506988
Flex Displacement @ Yield (in.) (ASTM D 790)		0.531	0.142	0.156
Flex Stress @ Yield (psi) (ASTM D 790)		17114	16662	15132
Heat Deflection Temp. (°F) (ASTM D 648)		111.7	144.5	131.8

[0043] When the resin was reinforced, the hardness increased and with it the tensile displacement and flex displacement decreased dramatically as the material became more metal-like. Accordingly, the tensile and flex modulus were increased significantly. With glass and sorbent reinforced nylon (without glass reinforcement), the tensile and flex stress was substantially maintained. The important feature and the significance of this finding was that the properties of the sorbent reinforced nylon vary from pure nylon in the same way as

does glass reinforced nylon, both in direction and magnitude. In addition, the heat deflection temperature was increased. Heat deflection temperature is a measure of heat resistance. This term is known among those skilled in the art. It is an indicator of the ability of the material to withstand deformation from heat over time. A further implication of the increased heat deflection temperature was an increase in the service temperature of a part molded from the sorbent reinforced resin.

[0044] It was also found that structures molded from sorbent reinforced nylon resin (without glass reinforcement) are isotropic as evidenced by the fact that tensile and flex modulus were substantially the same in one direction as another. As further evidence, shrinkage out of a mold is minimal and symmetrical.

EXAMPLE 2

[0045] Further experiments were performed using compositions comprising polypropylene, namely Huntsman Polypropylene 6106. This resin was also compatible with refrigerants, as well as with compressor lubricant. It was compounded in a similar fashion as nylon in Example 1, namely: 60% polypropylene resin and 40% molecular sieve Type 4A. The resin was heated above 174°C. The compounded resin had similar advantageous mechanical properties compared to the pure resin, and performs, structurally, close to that of a glass reinforced resin. Its properties are summarized in Table II. The values were determined by the same ASTM standards as provided in Table I.

Table II: Properties of Reinforced Polypropylene					
Property:	Material :	PP Neat	Molecular Sieve Reinforced Polypropylene	Glass Bead Reinforced Polypropylene	Glass Fiber Reinforced Polypropylene
Loading (%)		0	37.5	41.9	39.4
Hardness – Shore D		66.8	74.6	65.6	75.4
Tensile Modulus (psi)		131242	228023	159321	342977
Tensile Displacement @ Max Load (in.)		0.330	0.137	0.274	0.222
Tensile Stress @ Max. Load (psi)		3583	3169	2188	15996
Flex Modulus (psi)		113251	219377	158136	737113
Flex Displacement @ Yield (in.)		0.597	0.356	0.468	0.176
Flex Stress @ Yield (psi)		14.368	14.298	9.781	60.7
Heat Deflection Temp. (°F)		121.3	145.1	128.8	n/a

[0046] Reinforcement of polypropylene resulted in increased hardness and increases in tensile and flex modulus. For each of these properties the sorbent alone demonstrated even greater reinforcement effect than glass bead reinforcement. Accordingly, tensile displacement and flex displacement were reduced as the material became more rigid. Again, the effect of the sorbent was directionally the same as, but greater than glass bead reinforcement. Tensile and flex stress were reduced only slightly with sorbent reinforcement. However, the reduction was greater with glass reinforcement. With polypropylene, the reinforcement with sorbent was generally more effective than with glass bead reinforcement. The heat deflection temperature was increased. Here again, a further implication of the increased heat deflection temperature was an increase in the service temperature of a part molded from the sorbent reinforced resin.

[0047] Similarly, it was further found that structures molded from sorbent reinforced polypropylene resin were isotropic as evidenced by the fact that tensile and flex modulus

were substantially the same in one direction, as another. As further evidence, shrinkage out of a mold was minimal and symmetrical.

EXAMPLE 3

[0048] As may be seen in Table III, melt flow was reduced with sorbent reinforced nylon compared with nylon neat (pure polymer) or glass bead reinforced nylon. Nevertheless it was in a workable range and was higher than polypropylene. Melt flow of sorbent reinforced polypropylene was improved relative to polypropylene neat or glass reinforced polypropylene.

Table III: Melt Flow Properties of Sorbent Reinforced Polymers			
Melt Flow Index (g/10 min) (ASTM D 1238)	Neat	Molecular Sieve Reinforced	Glass Bead Reinforced
Nylon	56.3	14.7	55.5
Polypropylene	5.3	7.3	2.1

EXAMPLE 4

[0049] Moisture adsorption as a percentage of part weight is significant. This may be seen in Table IV. In practice, molecular sieve will adsorb about 25% of its own weight. It is reasonable then to expect a 40% loaded polymer to adsorb 10% of its own weight. In the case of nylon, however, adsorption reaches 13% in a 90% relative humidity (RH) environment, while the capacity is closer to 10% in an 80% RH environment. This was presumably the result of the action of the sorbent coupled with adsorption of some water by the nylon itself. The fact that the body as a whole adsorbs in excess of 10% indicates that the sorbent in addition to reinforcing the nylon was fully functional as a sorbent even though dispersed in the polymer. There was, in effect, a synergistic effect, or a double duty by the sorbent. Table IV shows results of adsorption at 36 - 38% molecular sieve loading.

Table IV: Adsorption Properties of Sorbent Reinforced Polymers				
Moisture Adsorption @ 29°C, 90% r.h.	2 Days	10 days	23 days	38 Days
Molecular Sieve Reinforced Nylon	5.4%	12.4%	13%	13%
Molecular Sieve Reinforced Polypropylene	1.1%	2.8%	4.4%	5.7%

[0050] Polypropylene is hydrophobic and is thus much slower to adsorb moisture. But it is fully functional as a sorbent while being fully functional as a molding resin.

[0051] Additional applications of this invention are numerous. Such applications would include any resin bonded component or structure used in an air conditioning or refrigeration system. As discussed above, examples include J-tubes that are injection molded in halves and welded or possibly injection blow-molded, sleeve liners, coatings for an interior part or shell, co-injection molded composite structures, and insert molded filter-dryer assemblies. Diagnostic applications would include test strip substrates, case or supports for E-trans cases, containers or components of containers for diagnostic products. Pharmaceutical applications would include parts of a tablet container, such as a base, or closure, or the body of the container itself, an insert into a tablet container such as a bottom support or a neck insert to aid in dispensing, a thermoformed sheet or as a layer of a multilayer thermoformable sheet suitable for one-at-a-time or two-at-a-time dose dispensing from a blister or other compartmented package. Monolithic cylindrical canisters for use in pharmaceutical bottles may also be formed from resin bonded sorbent materials, thereby providing a drop-in replacement for hollow canisters filled with particulate sorbent material. Electronics and electro-optical device applications would include complete breather filter bodies, inserts for night vision sensor units, or inserts for rear view camera bodies.

[0052] It will be appreciated that there are many other potential applications for a sorbent loaded injection moldable resin in closed systems and sealed packaging applications. It must also be appreciated that a sorbent loaded injection molding resin can also be extruded

into a rod or channel or any other shape with a uniform cross-section because extrusion is a less demanding process than injection molding.

[0053] The resin bonded sorbents described above and herebelow overcome the drawbacks of the prior art materials. Specifically, the instant invention is less brittle, *e.g.*, parts formed from the resin bonded sorbents are capable of passing drop tests without part failure, the parts adsorb fluid at slower rates thereby extending their useful life and minimizing the effects of manufacturing environments, they can be regenerated slowly and by combining sorbent properties with structural characteristics, the number of parts within an assembly may be reduced, *i.e.*, a cost reduction as one part will serve two purposes. The instant invention resin/sorbent matrices are less expensive to manufacture and use due to the use of conventional resin, reduced processing steps and the use of multi-resin materials which do not create phase boundaries. Additionally, older metal housings can be replaced with resin bonded sorbent housings thereby providing an active barrier against moisture or other fluid ingress, providing far greater design flexibility, weight reduction and cost savings as previously mentioned.

[0054] When a circuit board is heated to melt and reflow the solder to secure electrical connections, the board may be subject to damage due to moisture adsorbed within the board material. Thus, in one embodiment, resin bonded sorbents may be used to form a circuit board. A circuit board having a sorbent entrained in the board material will remain dry and greatly reduce or eliminate damage during solder reflow. In a sealed electronic device housing having a circuit board formed from a resin bonded sorbent, other components within the sealed housing will be protected over the service life of the device.

[0055] In another embodiment, resin bonded sorbents may be used to form overmolded pressed multiforms. First, a sorbent is formed by pressing, sintering or molding a resin bonded sorbent material. Pressing and molding can be accomplished with heat and/or pressure. Subsequently, the sorbent is overmolded with a structural, protective resin, which at least partially encloses the sorbent. The overmold may include tabs or other features suitable for mounting within or attaching to a sealed electronic or data storage device. As with the examples described above, the sorbent may be any of the desiccant class or volatile adsorbent class chosen to adsorb moisture or other fluids which could damage or limit the service life of the protected device. In this embodiment, the overmolding resin may be any suitable thermoplastic or thermoset resin which has the required properties and is otherwise compatible with the sealed electronic or data storage device being protected.

[0056] In yet another embodiment, resin bonded sorbents may be used to form structural components of optical and electro-optical devices. For example, a lens, lens mount, lens retaining ring, aperture, housing, etc. may be formed from a resin bonded sorbent material and thereafter incorporated within an assembly as the pre-existing part was incorporated. Thus, in this embodiment, the resin bonded sorbent will prevent condensation within the assembly which would typically cloud lenses or other optical surfaces thereby degrading of image quality. Furthermore, if the sorbent material is of the indicating type, *e.g.*, color change above a specific moisture content, the condition of the part will be readily apparent in so far as whether the part is still capable of adsorbing. When using indicating sorbent material, the devices which incorporate such material may include a window to allow a user to see, for example, the color change which communicates the need to change the part to the user.

[0057] In still another embodiment, resin bonded sorbents may be used to form components that merely fill available empty space while providing sorbent capabilities. Thus, no additional enclosure space is required to include a sorbent in a pre-existing assembly. For example, a hard drive typically has very little space available within its housing, however sorbent capacity is still required to provide a suitable environment for prolonged life of the drive. According to this embodiment, multifunctional sorbents may be incorporated into the interior drive components or provided as an overmolded multiform, as described *supra*. As with other embodiments, the sorbents may include desiccants, volatile organic adsorbers, volatile acid adsorbers or oxygen adsorbers.

[0058] Some electronic devices may be used in exceedingly aggressive environments, *e.g.*, aerospace and aviation applications. Electronic devices are used extensively in avionics and communications systems in aircraft and aerospace applications. Moisture and other volatiles may adversely affect the service life of such devices. Devices such as sensors, transmitters, antennae, radar units, etc. which are externally mounted are particularly at risk from moisture ingress due to temperature and pressure changes leading to evaporation and recondensation of moisture within the housings of such devices. Moreover, internally mounted devices are vulnerable due to variations in temperature as service conditions vary. Thus, resin bonded sorbent articles are quite beneficial when included in these types of devices.

[0059] Similarly, automotive electronics are used in environments which may vary in type from a desert to a mountain top to a tundra. These devices may include, for example,

backup and night vision cameras and sensing and control circuitry mounted in the exterior, or under the hood of an automobile or truck. By using resin bonded sorbent material to form a housing or internal part, moisture ingress may be prevented or its effects mitigated. Additionally, electronically controlled braking systems can be protected from moisture ingress, as these systems are subject to conditions at extreme temperatures. For example, brake fluid, which is hygroscopic and in contact with several electronic controls, may change from an ambient winter temperature of zero degrees centigrade (0°C) to three hundred fifty degrees centigrade (350°C) in a very short period of time under high braking condition, *e.g.*, going down a large hill. Preventing moisture ingress into the brake fluid not only prolongs electronic component service life, but also maintains safer conditions, *i.e.*, as water content increases in brake fluid, its boiling point lowers so that under normal operating conditions the liquid becomes a vapor and braking power is essentially lost. In like fashion, gauges and electronic displays for boats, RVs, ATVs and military rough terrain vehicles are also exposed to aggressive environments where the incorporation of the instant invention would be quite beneficial. In particular, marine and submersible applications expose electronics to electrolyte solutions where corrosion is accelerated. In like fashion, automotive and marine devices benefit by incorporating resin bonded sorbent articles within the device.

[0060] Surveillance and security devices, *e.g.*, light/motion/heat sensors and security cameras, must operate reliably in a wide range of temperature and humidity. For example, an external security camera mounted on a bank in Buffalo, New York can see temperatures as high as thirty seven degrees centigrade (37°C) and as low as minus twenty three degrees centigrade (-23°C), while experiencing relative humidity levels from ninety five percent (95%) down to twenty percent (20%). Thus, using the instant invention resin bonded sorbents to form a device housing or internal component is particularly advantageous for extending service life of such devices.

[0061] Another aggressive environment where electronic devices are prevalent is in hazardous chemical production and use. Sensors, controls and switch gear must operate in these environments while being protected from hazardous and/or corrosive vapors. Thus, using an appropriate sorbent, *e.g.*, desiccant, activated carbon, zeolites, clays and organic sorbents, in a resin bonded sorbent housing or internal component of such devices will prolong its service life. Similarly, industrial use personal computers (PCs) and programmable logic controllers (PLCs) must operate in harsh industrial environments, *e.g.*,

high humidity. Hence, forming a housing or internal component of these devices from the instant invention resin bonded sorbents will prolong the service life of these PCs and PLCs.

[0062] Yet another aggressive environment where electronic devices are becoming more prevalent is inside the human body, *i.e.*, implantable and/or attachable electronic medical devices. These types of devices must function continuously and reliably in a moist, saline environment, or in other words, an environment where corrosion conditions are optimal. An appropriate resin bonded sorbent housing, or internal resin bonded sorbent part, can maintain dryness and enhance longevity and reliability of these devices. In addition to the implantable and attachable medical devices, medical diagnostic equipment must also be maintained in reliable working condition, *i.e.*, dry electronics. Thus, using the instant invention to form a housing or internal component is particularly advantageous.

[0063] Mobile and stationary telecommunication devices are also exposed to adverse and aggressive environments. Terminals and switch gear would have longer service life and lower maintenance if the interior of their housings were kept dry. Thus, a housing or internal part formed from the instant invention would keep the device dry, thereby minimizing current leakage and shorts, inhibiting dendrite formation and electrolytic/chemical corrosion. In addition to moisture adsorption, suitable sorbents may be included to address other volatiles present within the housing.

[0064] Other electronic devices, *e.g.*, solar panels or day/night sensors, present other problems to overcome. Commercial photovoltaic devices consist of flat, nearly all glass panels which are coated with a moisture sensitive photoactive substance. The panels are sealed to each other in the manner of a thermo-pane window. Sealants may be used around the perimeter, or the panels may be mounted in a frame. Additionally, ports and openings into the panel for electrical connections must be sealed. Frame materials or fitments for electrical connections may be made from resin bonded sorbent which can simultaneously provide the mechanical strength and sorbent properties required to contain and protect moisture sensitive, fragile solar panels.

[0065] Radio frequency identification (RFID) devices are made from semiconductor chips and associated circuitry. Circuit boards may be used, however imprinted circuitry is more prevalent. RFID devices, and in particular organic RFID devices, are often used in adverse environments where they may degrade due to moisture, oxygen or volatile chemicals. Thus, RFID devices may be improved by manufacturing support structures or housings from

polymeric resins with properties enhanced by sorbent additives capable of extending the life of RFID devices, *e.g.*, desiccants or oxygen adsorbents.

[0066] Light emitting diodes (LEDs) and liquid crystal diodes (LCDs) are made from materials which are moisture sensitive. In particular, organic LEDs and LCDs are highly moisture sensitive. Sorbent materials are added to displays to improve and extend service life, usually in thin film or sheet form. According to the instant invention, a structural support or sealant material can be made from resin bonded sorbents, thereby providing moisture protection, *i.e.*, extending service life, while also providing the structural, mounting or sealing functionality of a pre-existing component. In like fashion, flexible electronic displays are highly moisture sensitive. Chromophores used in their construction are moisture sensitive and therefore can be stabilized by incorporating a resin bonded sorbent within the displays.

[0067] Even traditional lighting devices, for example, household lighting and automobile headlamps, will benefit by including the instant invention. Condensation on lenses may be prevented, thereby prolonging bulb and service life of such devices, while eliminating loss of reflected light.

[0068] Solid state surface mount electronic devices housed in plastic enclosures are considered nonhermetic due to the moisture permeability of the plastic. The basic issue is vapor pressure change of water during solder reflow cycle causing damage, which may lead to delamination, cracking, leaking and “popcorning”. Currently, low moisture sensitivity is achieved by the choice of materials, design of package and good processes. Resin bonded sorbent enclosures will inhibit moisture ingress, effectively making a hermetic seal until the sorbent becomes saturated. Examples of such devices include, but are not limited to, radio frequency, wireless, local area network (LAN) and broadband devices, as well as electronic chip mountings and packaging.

[0069] As described *supra*, imaging devices present issues different than part degradation. The presence of moisture combined with a change in temperature can cause condensation on a lens or window of an imaging device. Condensation quickly degrades image quality and may render imaging devices non-functional. Such devices are known to require moisture control when the service environment is moist and subject to temperature fluctuation. Thus, an article made from resin bonded sorbent, *e.g.*, lens retaining ring, aperture, housing, etc., may be incorporated within the assembly thereby providing sorbent capabilities as well as structural support. Such optical devices may be used for sighting and/or sensing an object, for example, target acquisition and guidance sensors and systems.

In these systems, lasers and other sensing devices form a crucial part of the target acquisition and guidance systems, thus peak optical performance is necessary, *i.e.*, no condensation on optical surfaces.

[0070] In addition to sorbent capabilities, resin bonded sorbent material may be blended with other materials, *e.g.*, static dissipative (conductive) material, thereby providing multifunction capability, for example, moisture control and antistatic properties. Thus, these materials may be used in any of the above described electronic applications by adsorbing moisture while dissipating static charges.

[0071] Figure 10 shows a cross sectional view of an embodiment of the present invention, device 11. Device 11 includes housing 12 which includes first and second walls 14 and 16, respectively, and shoulder 18. As described *supra*, housing 12 may be formed from a resin bonded sorbent thereby slowing or preventing the ingress of fluid. Shoulder 18 provides a seat for lens 20, while first wall 14 provides a mounting location for sorbent article 22 and second wall 16 provides a mounting location for stand-offs 24 which fixedly secure circuit board 26 to housing 12. Sorbent article 22 includes sorbent 28 enclosed within overmold resin 30. Overmold resin 30 includes tabs 32 which are used to hold sorbent article 22 to first wall 14 via fasteners 34. As described above, circuit board 26 may also be formed from a resin bonded sorbent thereby providing sorbent capability within housing 12. Device 11 further includes gasket 36 and retaining ring 38. Gasket 36 is disposed between shoulder 18 and lens 20, while retaining ring 38 provides a positive force in the direction of gasket 36, thereby compressing gasket 36. The compression of gasket 36 seals housing 12 and prevents the ingress of fluids therein. Additionally, gasket 36, retaining ring 38 and/or lens 20 may be formed from a resin bonded sorbent material, which would provide a greater level of protection from fluid ingress. Device 11 further includes aperture 40 disposed between lens 20 and circuit board 26. Aperture 40 may also be formed from a resin bonded sorbent thereby providing further sorbent capacity. Although aperture 40 is shown as being formed from a resin bonded sorbent material, one of ordinary skill in the art will recognize that other articles may be formed from such materials and incorporated within device 11, for example, baffles, fasteners or stand-offs. Surface mount device 42 is fixedly secured to circuit board 26 via contacts 44. Surface mount device 42 further includes enclosure 46. Typically, surface mount device 42 would not be considered hermetically sealed as the enclosure materials are permeable to some fluids. Thus, by forming enclosure 46 from a resin bonded sorbent material, surface mount device 42 can be hermetically sealed.

[0072] As one of ordinary skill in the art will recognize, device **11** and the components contained therein are not limited to the particular embodiment shown in Figure 10. For example, housing **12** may be a fully sealed container having no lens **20** and/or no aperture **40**. Thus, it is within the spirit and scope of the invention that device **11** can comprise at least one article formed from resin bonded sorbent material which is selected from the group consisting of a lens, circuit board, housing, case, frame, support structure, mount structure, retaining structure, seal material, solid state surface mount device, electronic chip packaging, telecommunications terminal, telecommunications switch, a data storage device, electronic device, electro-optical device, scope, sensor, transmitter, antenna, radar unit, photovoltaic device, radio frequency identification device, light emitting diode, liquid crystal diode, semiconductor enclosure, imaging device, sighting device, cellular phone, target acquisition and guidance sensor, implantable electronic medical device, attached electronic medical device, mobile telecommunications device, stationary telecommunications device, automobile sensing circuit, automobile control circuit, braking control system, hazardous chemical sensor, hazardous chemical control, gauge, electronic display, personal computer, programmable logic unit, medical diagnostic equipment, light sensor, motion sensor, heat sensor, security camera, flexible electronic device, lighting fixture, marine gauge, marine light, external aircraft sensing device, external aircraft monitoring device, external aircraft measuring device, power tool sensing device, power tool sighting device, power tool measuring device, laser and combinations thereof.

[0073] Figure 11 is a perspective view of an embodiment of a present invention lamp assembly **50**, while Figure 12 is an exploded view of lamp assembly **50**. Figure 13 is a cross sectional view of lamp assembly **50** taken generally along line **13-13** of Figure 11, while Figure 14 is a cross sectional view of lamp assembly **50** taken generally along line **14-14** of Figure 11. Figure 15 is a cross sectional view of another embodiment of a present invention lamp assembly, *i.e.*, lamp assembly **52**, while Figure 16 is a perspective view of yet another embodiment of a present invention lamp assembly, *i.e.*, lamp assembly **54**. The following discussion is best understood in view of Figures 11 through 16.

[0074] Lamp assembly **50** comprises at least one light source, *e.g.*, light sources **56**. It should be appreciated that the at least one light source may be an LED or other type of light source, and such variations are within the spirit and scope of the claimed invention. Furthermore, the at least one light source may be arranged on a mounting board, *e.g.*, circuit board **57**, or may be positioned as a discrete component. Lamp assembly **50** further

comprises housing 58 formed from a first moisture barrier composition and sealing cap 60 formed from a second moisture barrier composition. The at least one light source, *e.g.*, light sources 56, is arranged within housing 58 and sealing cap 60 is hermetically bonded to housing 58 and the at least one light source. As can be seen in the figures, in some embodiments, sealing cap 60 includes at least one hole, *e.g.*, holes 61, arranged for receipt of the at least one light source therein. Sealing cap 60 is arranged to enclose the at least one light source within volume 62 formed by housing 58 and sealing cap 60. It should be further appreciated that lamp assembly 50 may also comprise lens 63 arranged to control the path of light emitting from the at least one light source; however, lens 63 is not particularly germane to the present invention.

[0075] In the embodiments shown in the figures, the first moisture barrier composition comprises a blend of a first resin and a first sorbent and the second moisture barrier composition comprises a blend of a second resin and a second sorbent; however, it should be appreciated that other variations are also possible. For example, the first resin can be the same as the second resin and the first sorbent can be the same as the second resin, the first resin can be different than the second resin and the first sorbent can be the same as the second resin, the first resin can be the same as the second resin and the first sorbent can be different than the second resin, or the first resin can be different than the second resin and the first sorbent can be different than the second resin. Such variations are within the spirit and scope of the claimed invention.

[0076] As described above, the resins used for the present invention lamp assembly may be thermoplastic or may be selected from the groups consisting of polyamide, polyolefin, styrenic polymer, polyester and homogeneous mixtures thereof. Examples of polyolefins include high density polyethylene, low density polyethylene and polypropylene. Similarly, the sorbents used for the present invention lamp assembly may be selected from the group consisting of a molecular sieve, a silica gel, an ion exchange resin, an activated alumina, a clay, a salt, a zeolite and mixtures thereof.

[0077] Several techniques of hermetically sealing a present invention lamp assembly can be used and such techniques are within the spirit and scope of the claimed invention. For example, sealing cap 60 is hermetically bonded to housing 58 and the at least one light source, *e.g.*, light sources 56, with welding, or sealing cap 60 is hermetically bonded to housing 58 and the at least one light source with an adhesive or an epoxy. In various embodiments, the welding technique may be selected from the group consisting of: sonic welding, ultrasonic

welding, spin welding, hot plate welding and vibration welding, and such techniques are well known in the art. In both embodiments, surface 64 of sealing cap 60 is hermetically bonded to surface 65 of housing 58 and surface 66 of light sources 56. As used herein, “hermetically sealed” and “hermetically bonded” are intended to mean a seal or bond which prevents the flow of fluid, gas or vapor from one side of the sealed or bonded region to the opposite side of the sealed or bonded region. For example, when sealing cap 60 is hermetically bonded to housing 58 and the at least one light source, no fluid, gas or vapor can flow from outside of housing 58 to volume 62, *i.e.*, the volume created within housing 58 and sealing cap 60. It should be appreciated that any sonic welding techniques known in the art to bond two plastic substrates together may be used to bond the present invention lamp assembly, *e.g.*, lamp assembly 50. Similarly, any adhesive or epoxy known in the art to bond two plastic substrates together may be used to bond the present invention lamp assembly.

[0078] In some embodiments, for example the embodiment shown in Figure 15, sealing cap 60 can be molded directly over and to housing 58 and the at least one light source, *e.g.*, light sources 56. Such a technique is commonly known as overmolding, and creates a hermetic bond or seal between sealing cap 60, housing 58 and the at least one light source. As with the above described embodiments, any overmolding techniques known in the art to bond two plastic substrates together may be used to bond the present invention lamp assembly.

[0079] In some embodiments, the at least one light source further comprises at least two electrical connections, *e.g.*, electrical connections 68, and housing 58 further comprises at least two openings, *e.g.*, openings 70, arranged to receive the at least two electrical connections therethrough. In such embodiments, the at least two electrical connections and the at least two openings are hermetically encapsulated by a third moisture barrier composition. Similar to the embodiments described above, the third moisture barrier composition comprises a blend of a third resin and a third sorbent, and the third resin and/or the third sorbent may be the same as or different than the first and second resins and the first and second sorbents, respectively. Also as described above, the third resin may be a thermoplastic resin, or may be selected from the group consisting of polyamide, polyolefin, styrenic polymer, polyester and homogeneous mixtures thereof. Examples of preferred polyolefins include high density polyethylene, low density polyethylene and polypropylene. The third sorbent is again selected from the group consisting of a molecular sieve, a silica gel, an ion exchange resin, an activated alumina, a clay, a salt, a zeolite and mixtures thereof.

[0080] Several techniques of hermetically encapsulating the at least two electrical connections and the at least two openings can be used, and such techniques are within the spirit and scope of the claimed invention. For example, the at least two electrical connections, *e.g.*, electrical connections **68**, and the at least two openings, *e.g.*, openings **70**, can be hermetically encapsulated by the third moisture barrier composition with welding or with an adhesive or an epoxy, as described above. As used herein, “hermetically encapsulated” is intended to mean surrounding or encasing an item in such a way that the encasing prevents the flow of fluid, gas or vapor from one side of the encased region to the opposite side of the encased region. For example, when the at least two electrical connections and the at least two openings are hermetically encapsulated, no fluid, gas or vapor can flow from outside of housing **58** to volume **62**, *i.e.*, the volume created within housing **58** and sealing cap **60**, via the at least two openings. Similar to the embodiments described above, an overmolding technique may also be used to provide hermetic encapsulation of the at least two electrical connections and the at least two openings.

[0081] As can be seen in Figure 16, the present invention lamp assembly may take other forms than the embodiments shown in the previous figures, *e.g.*, lamp assembly **54**. Lamp assembly **54** comprises cylindrical housing **72** and round lens **74**. It should be appreciated that other shapes are also possible, *e.g.*, triangular or rhombus, and such shapes are within the spirit and scope of the claimed invention.

[0082] As described above, various embodiments of resin bond sorbent may be used as a barrier to the transmission of a vapor through a resin material, *e.g.*, a barrier to the transmission of water vapor through a polypropylene resin in combination with a molecular sieve. Thus, a lamp assembly comprising a housing and sealing cap, wherein both the housing and sealing cap are formed from a resin bonded sorbent material, effectively prevents the ingress of moisture into the lamp assembly.

[0083] Resins used in the present invention are prepared using specialized plastics compounding techniques. A preferred sorbent is molecular sieve which can be incorporated into polyamide and polyolefin resins by feeding the sorbent in powder form along with beads of the chosen resin to a plastics extruder with good mixing characteristics at a temperature and at a rate and concentration required to achieve full dispersion of the sorbent additive such that sorbent particles are fully wetted and coated with resin such that particles are separated from each other. A twin screw extruder is typically used. Multiple compounding steps may be used as necessary to achieve the claimed dispersion. Thus, the resin is melted and the

sorbent is mixed throughout. The extruded resin is cooled with air and then cut or crushed into pellets or granules. Since the compounding is accomplished at high temperature, the sorbent tends not to adsorb moisture and thus retains its capacity.

[0084] Although the present invention has been particularly described in conjunction with specific preferred embodiments, it is evident that many alternatives, modifications, and variations will be apparent to those skilled in the art. It is therefore contemplated that the appended claims will embrace any such alternatives, modifications, and variations as falling within the true scope and spirit of the present invention.

What we claim is:

1. A lamp assembly comprising:
 - at least one light source;
 - a housing formed from a first moisture barrier composition; and,
 - a sealing cap formed from a second moisture barrier composition, wherein said at least one light emitting device is arranged within said housing and said sealing cap is hermetically bonded to said housing and said at least one light source, and said sealing cap is arranged to enclose said at least one light emitting device within a volume formed by said housing and said sealing cap.
2. The lamp assembly of Claim 1, wherein said first moisture barrier composition comprises a blend of a first resin and a first sorbent and said second moisture barrier composition comprises a blend of a second resin and a second sorbent.
3. The lamp assembly of Claim 2, wherein said first resin and/or said second resin is a thermoplastic resin.
4. The lamp assembly of Claim 2, wherein said first resin and/or said second resin is selected from the group consisting of polyamide, polyolefin, styrenic polymer, polyester and homogeneous mixtures thereof.
5. The lamp assembly of Claim 4, wherein said polyolefin is selected from the group consisting of high density polyethylene, low density polyethylene and polypropylene.
6. The lamp assembly of Claim 2, wherein said first sorbent and/or said second sorbent is selected from the group consisting of a molecular sieve, a silica gel, an ion exchange resin, an activated alumina, a clay, a salt, a zeolite and mixtures thereof.
7. The lamp assembly of Claim 1, wherein said sealing cap is hermetically bonded to said housing and said at least one light source with welding.

8. The lamp assembly of Claim 7, wherein said welding is selected from the group consisting of: sonic welding, ultrasonic welding, spin welding, hot plate welding and vibration welding.
9. The lamp assembly of Claim 1, wherein said sealing cap is hermetically bonded to said housing and said at least one light source with an adhesive or an epoxy.
10. The lamp assembly of Claim 1, wherein said sealing cap is hermetically bonded to said housing and said at least one light source by molding said sealing cap over said housing and said at least one light source.
11. The lamp assembly of Claim 1, wherein said at least one light source comprises at least two electrical connections and said housing comprises at least two openings arranged to receive said at least two electrical connections therethrough, and wherein said at least two electrical connections and said at least two openings are hermetically encapsulated by a third moisture barrier composition.
12. The lamp assembly of Claim 11, wherein said third moisture barrier composition comprises a blend of a third resin and a third sorbent.
13. The lamp assembly of Claim 12, wherein said third resin is a thermoplastic resin.
14. The lamp assembly of Claim 12, wherein said third resin is selected from the group consisting of polyamide, polyolefin, styrenic polymer, polyester and homogeneous mixtures thereof.
15. The lamp assembly of Claim 14, wherein said polyolefin is selected from the group consisting of high density polyethylene, low density polyethylene and polypropylene.
16. The lamp assembly of Claim 12, wherein said third sorbent is selected from the group consisting of a molecular sieve, a silica gel, an ion exchange resin, an activated alumina, a clay, a salt, a zeolite and mixtures thereof.

17. The lamp assembly of Claim 11, wherein said at least two electrical connections and said at least two openings are hermetically encapsulated by said third moisture barrier composition with welding.

18. The lamp assembly of Claim 17, wherein said welding is selected from the group consisting of: sonic welding, ultrasonic welding, spin welding, hot plate welding and vibration welding.

19. The lamp assembly of Claim 11, wherein said at least two electrical connections and said at least two openings are hermetically encapsulated by said third moisture barrier composition with an adhesive or an epoxy.

20. The lamp assembly of Claim 11, wherein said at least two electrical connections and said at least two openings are hermetically encapsulated by said third moisture barrier composition by molding said third moisture barrier composition over said at least two electrical connections and said at least two openings.

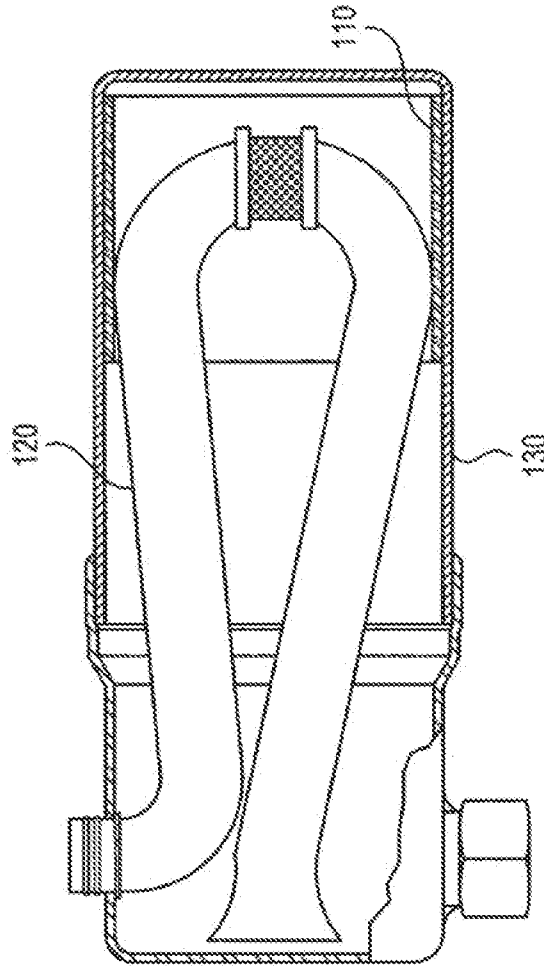

FIG. 2

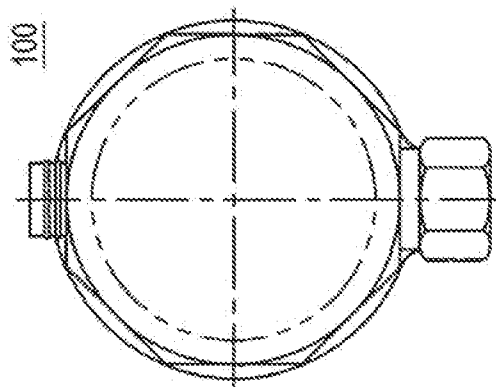

FIG. 1

2/12

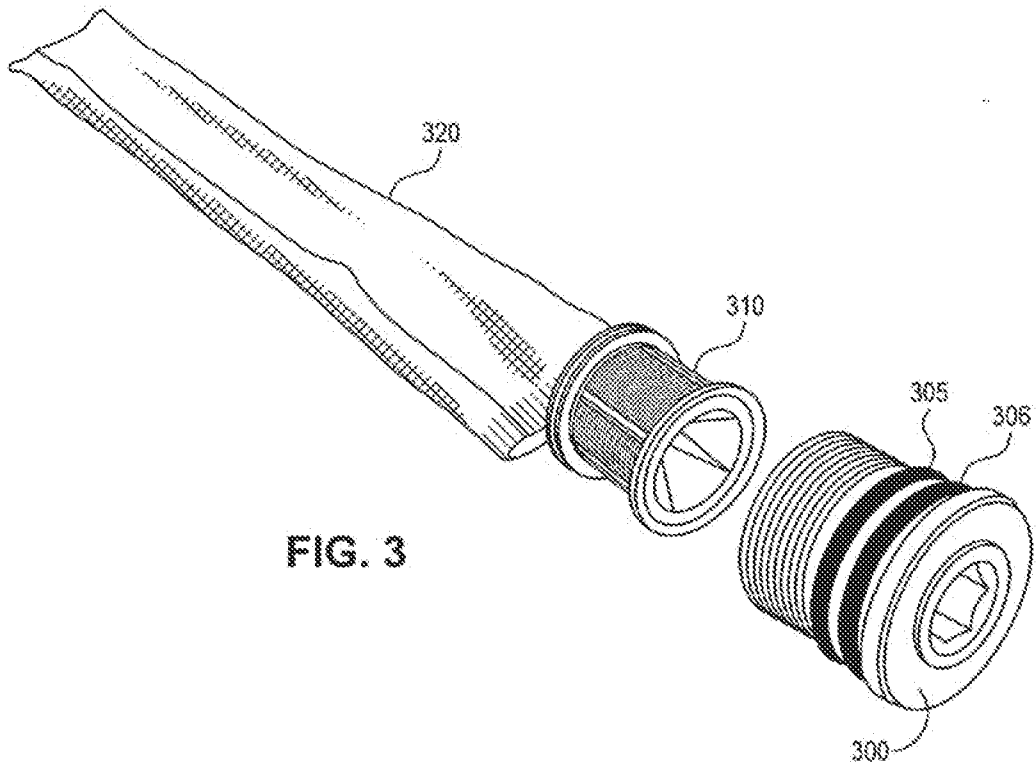

FIG. 3

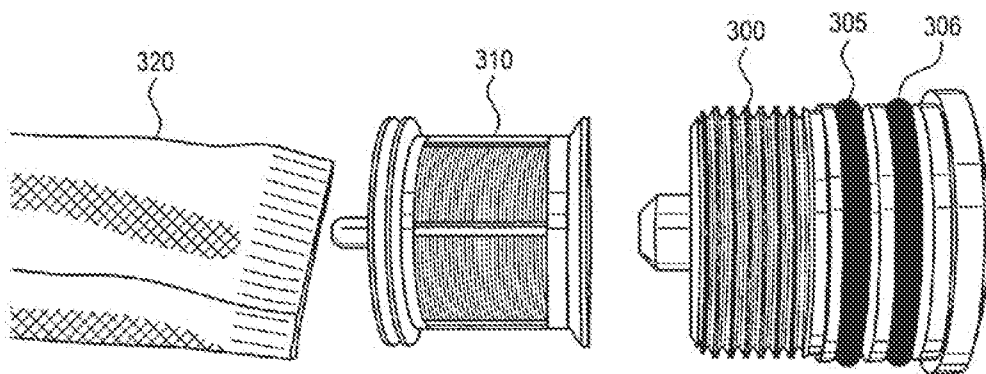

FIG. 4

3/12

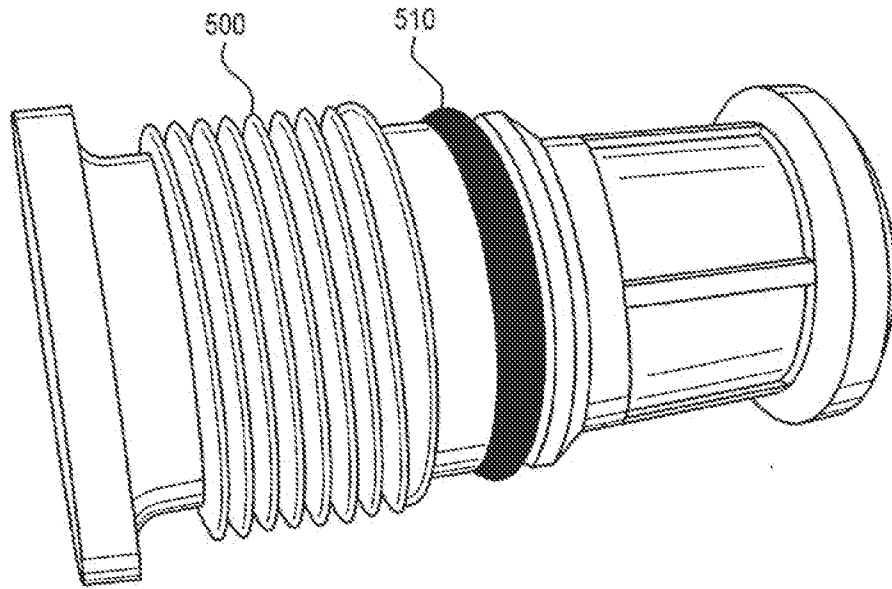

FIG. 5

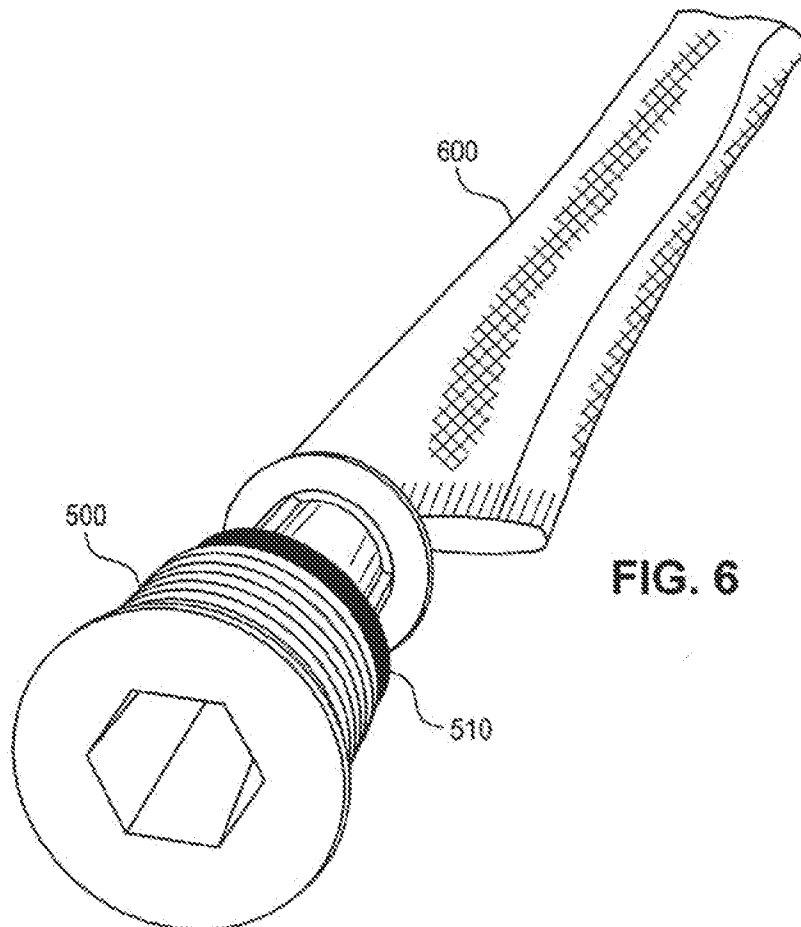

FIG. 6

4/12

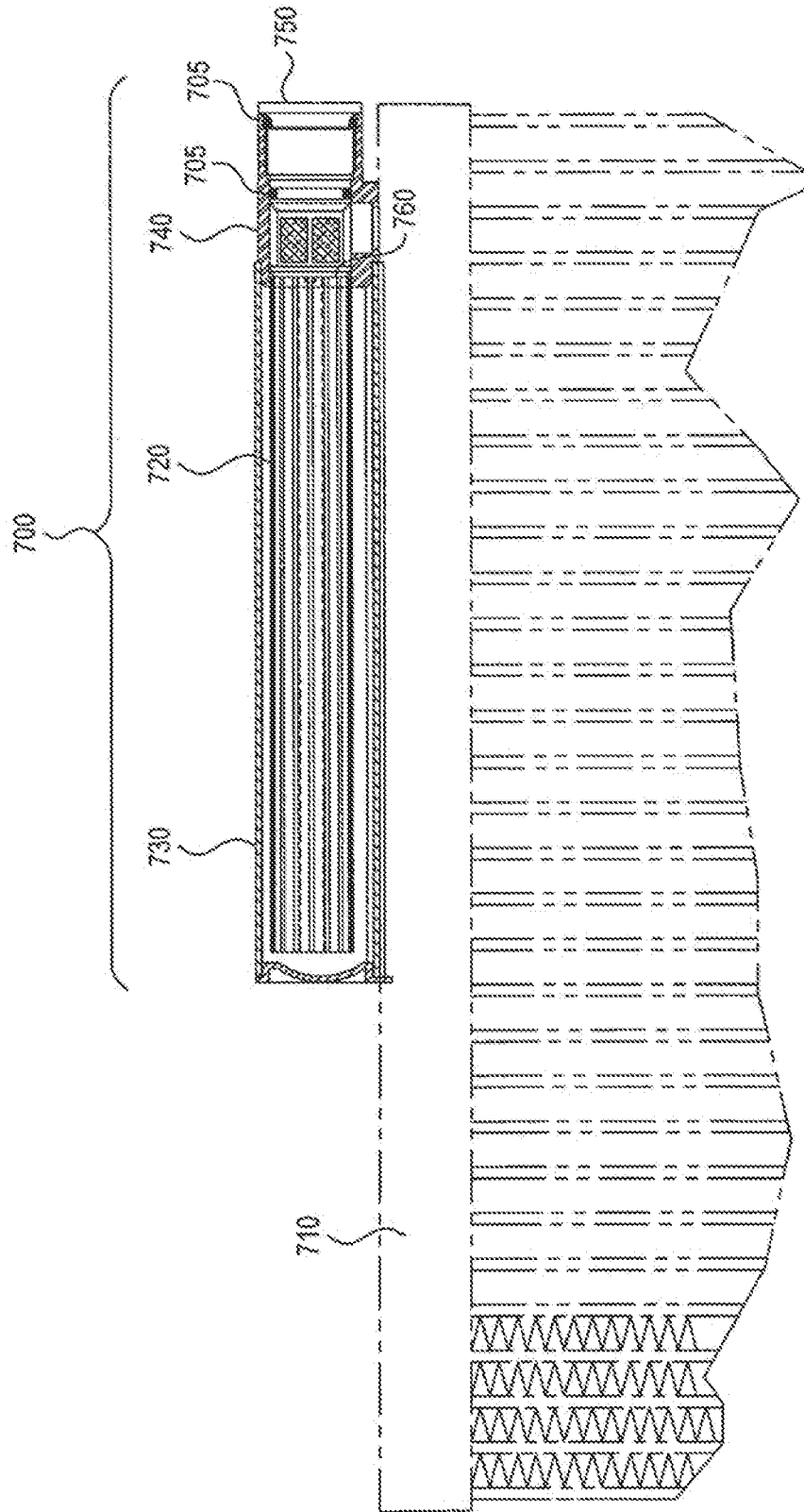

FIG. 7

5/12

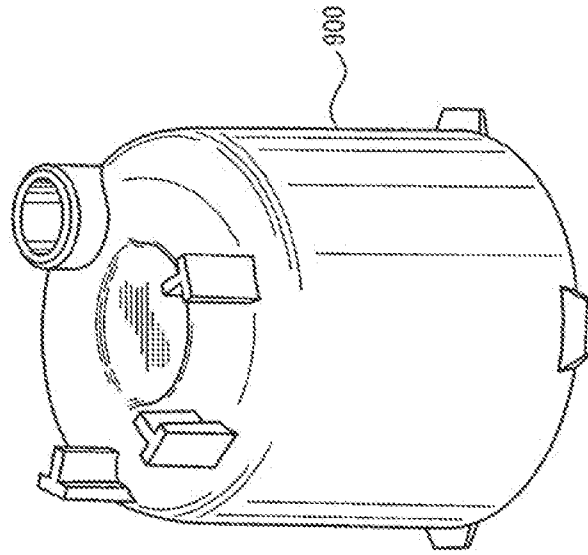

FIG. 9

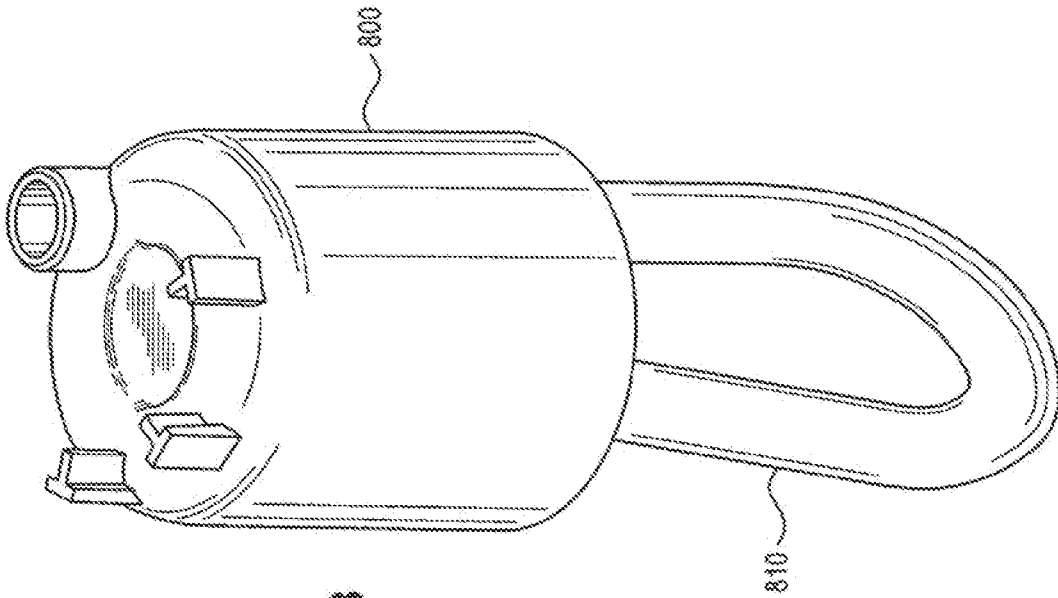

FIG. 8

6/12

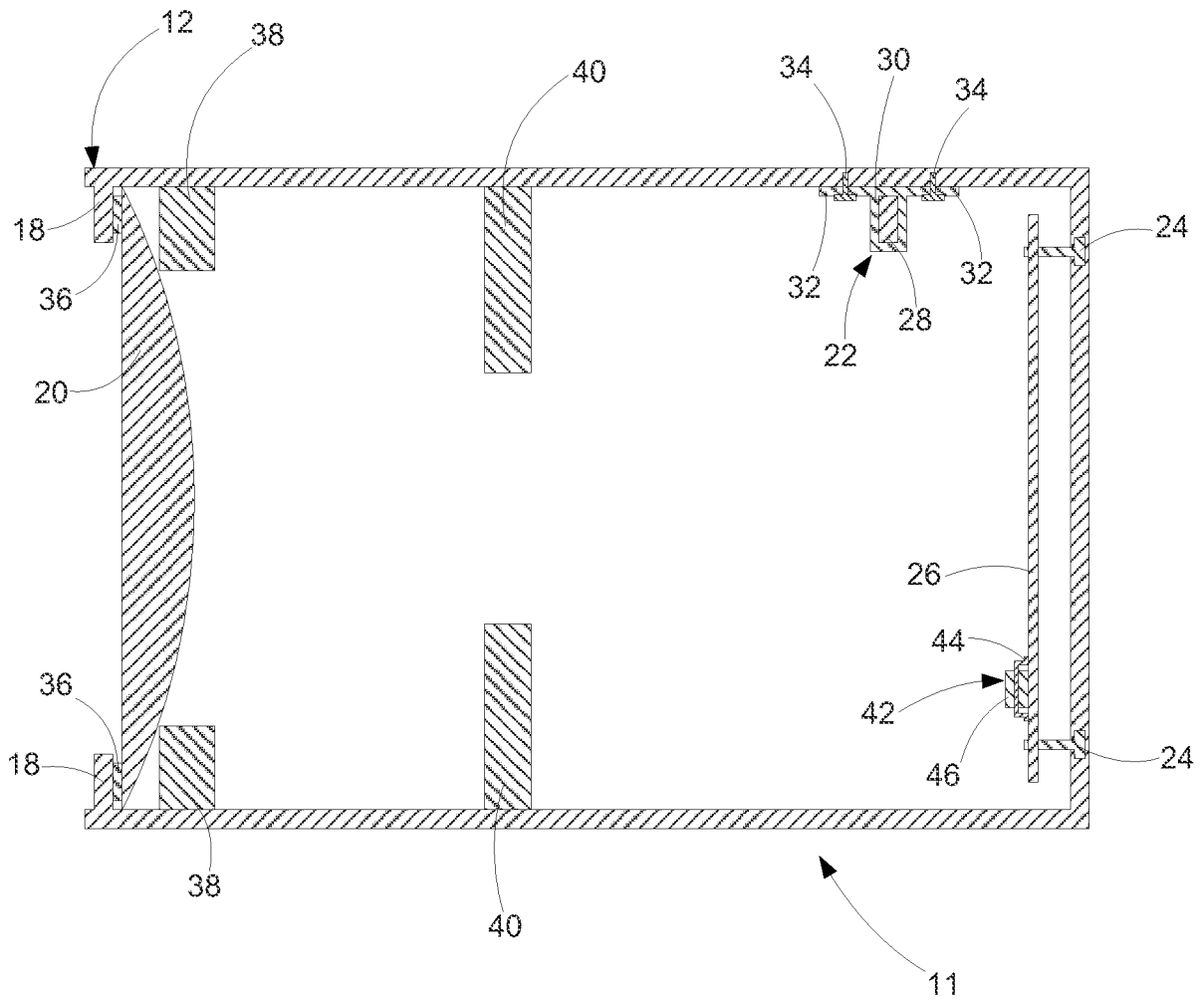

FIG. 10

7/12

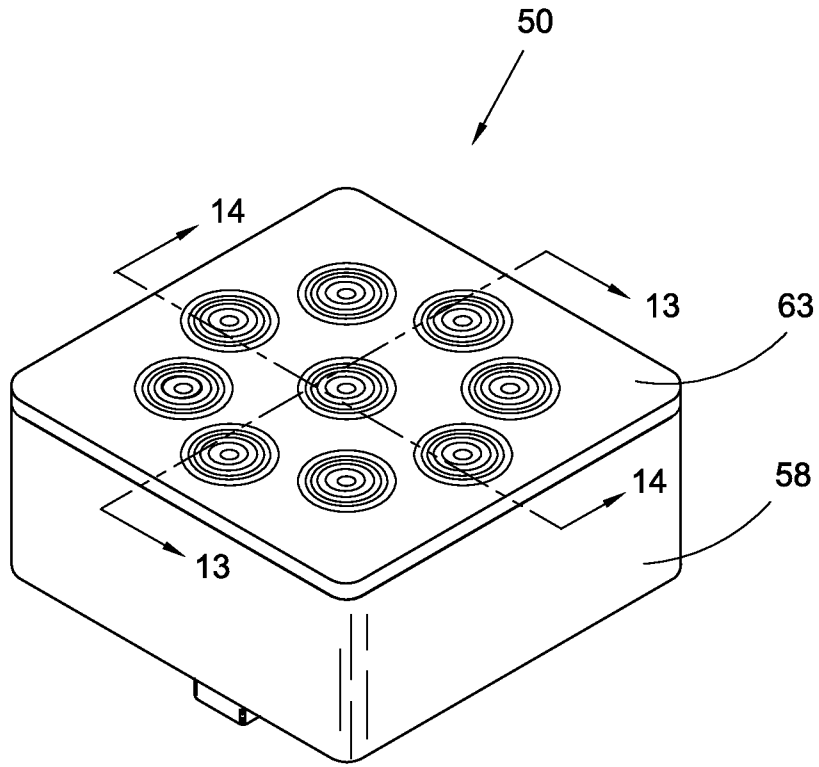

Fig. 11

8/12

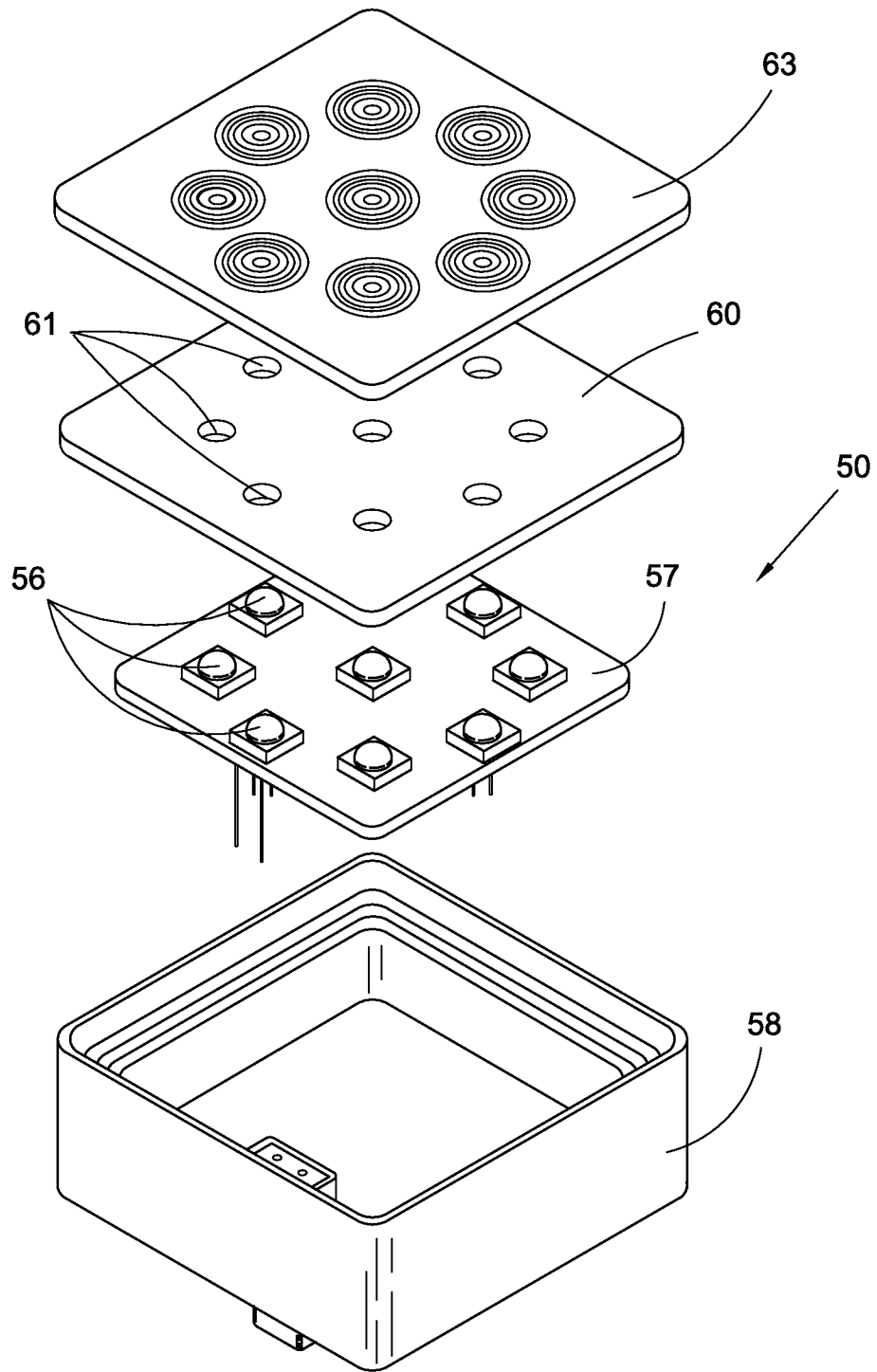

Fig. 12

9/12

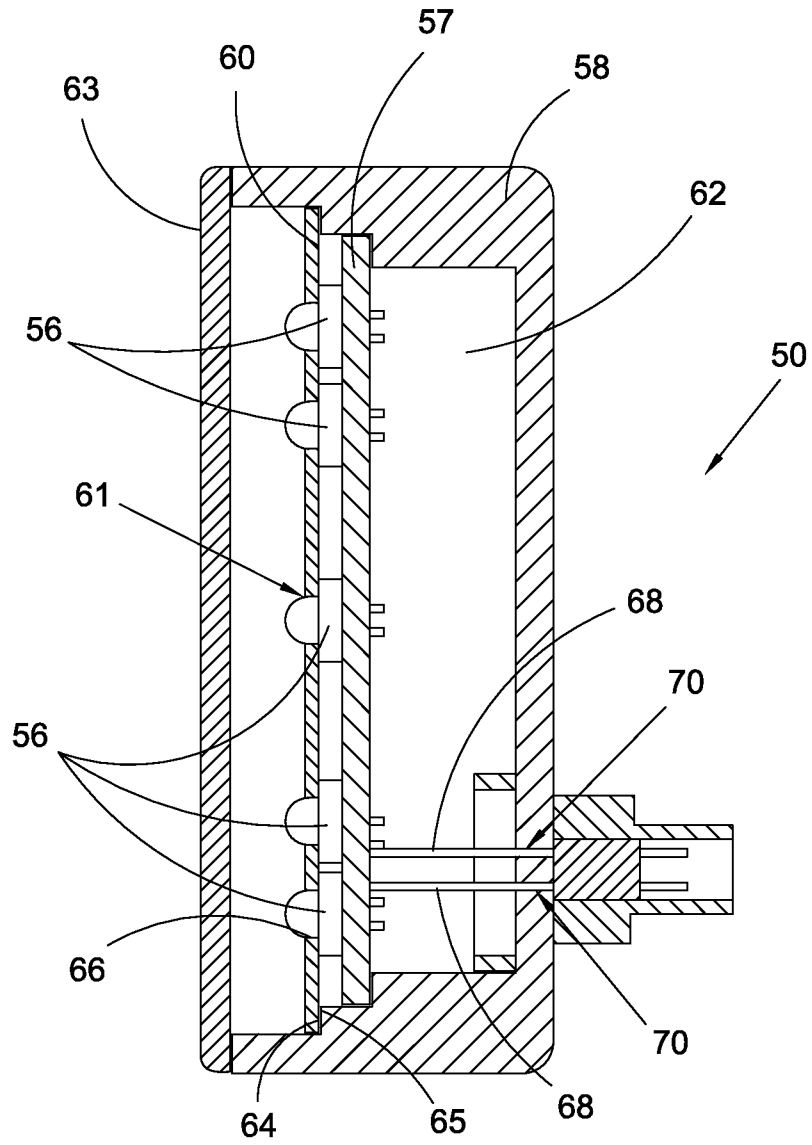

Fig. 13

10/12

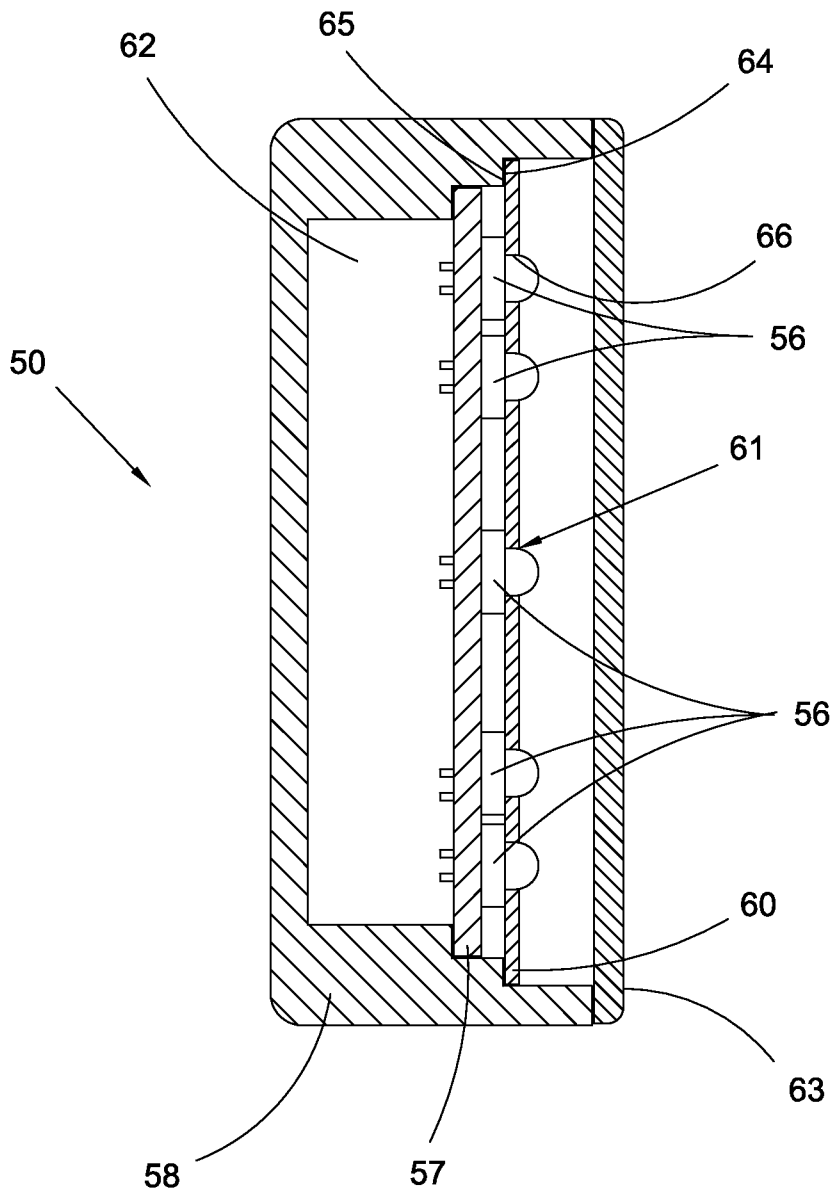

Fig. 14

11/12

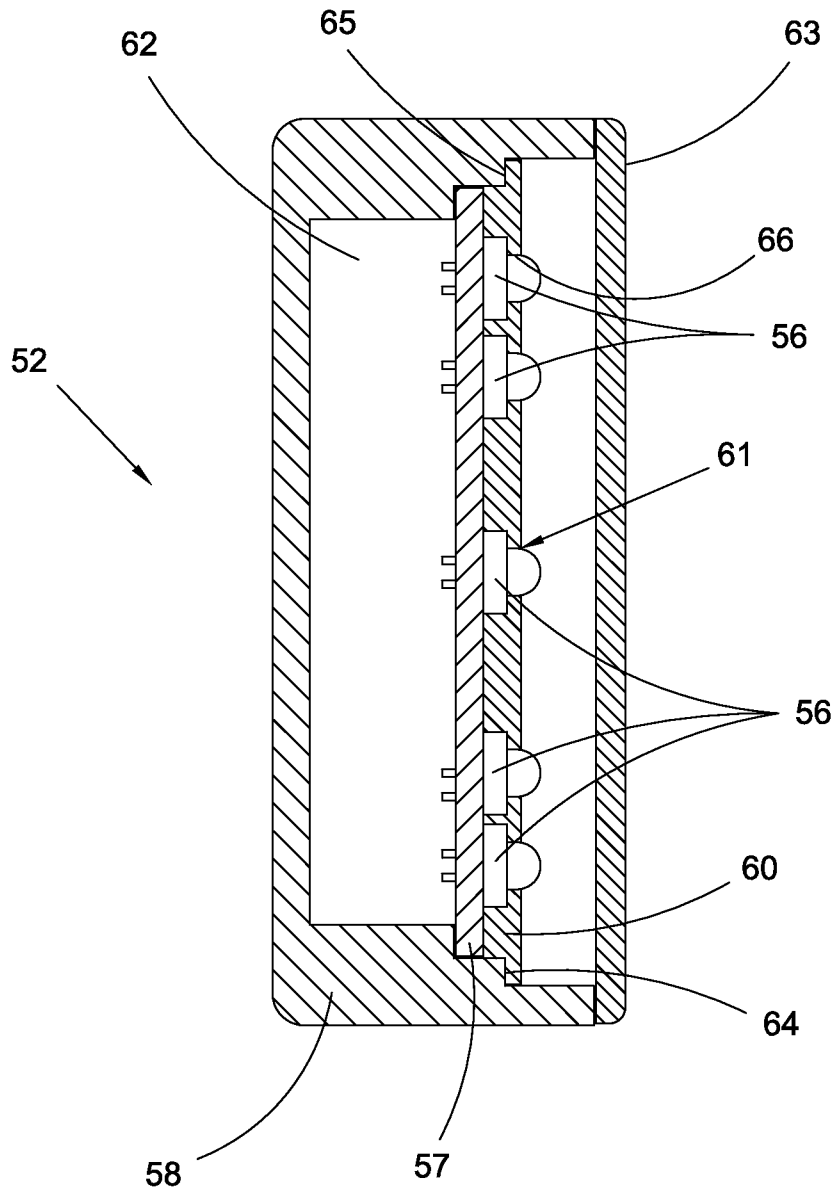

Fig. 15

12/12

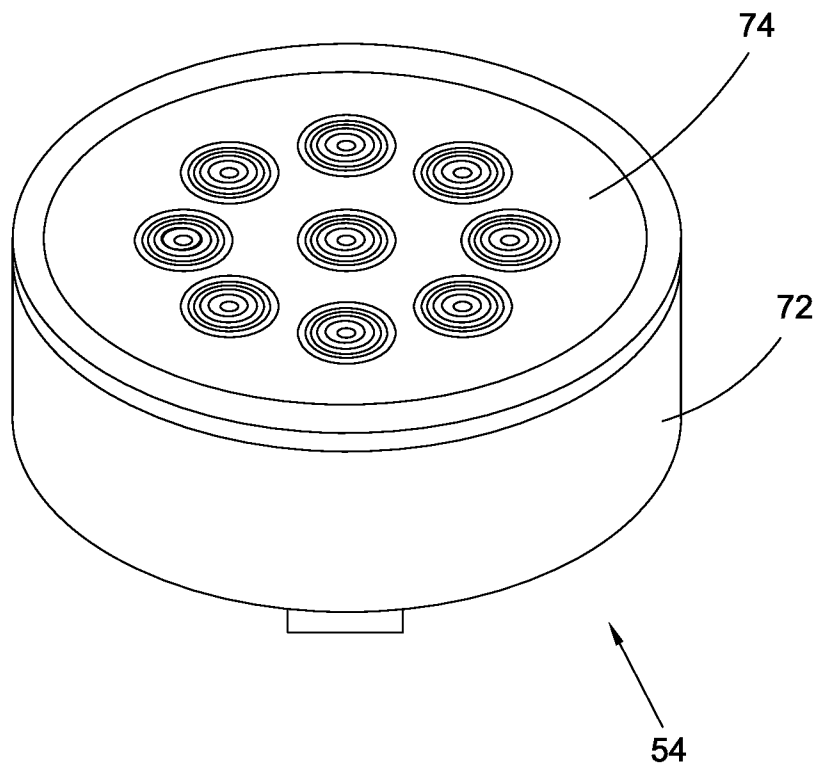

Fig. 16

INTERNATIONAL SEARCH REPORT

International application No.

PCT/US 09/41124

A. CLASSIFICATION OF SUBJECT MATTER

IPC(8) - F21V 15/00 (2009.01)

USPC - 362/376

According to International Patent Classification (IPC) or to both national classification and IPC

B. FIELDS SEARCHED

Minimum documentation searched (classification system followed by classification symbols)

IPC(8): F21V 15/00 (2009.01)

USPC: 362/376

Documentation searched other than minimum documentation to the extent that such documents are included in the fields searched

USPC: 362/362, 378; 313/498; 362/\$

Electronic data base consulted during the international search (name of data base and, where practicable, search terms used)

PubWEST (USPT, USOCR, PGPB, EPAB, JPAB); Google/Patents; Google/Web

Search terms: amp, light, illuminate, housing, body, base, enclosure, encase, cap, lid, covering, cover, seal, sorbent, absorbent, weld, bond, adhesive, glue, epoxy, silica, gel, clay, alumina, zeolite, moist, wetness, damp, dessicate, dope, embed, impregnate, resin, etc.

C. DOCUMENTS CONSIDERED TO BE RELEVANT

Category*	Citation of document, with indication, where appropriate, of the relevant passages	Relevant to claim No.
Y	US 6,406,167 B1 (BOCK) 18 June 2002 (18.06.2002), col 1, lns 8-10; col 3, lns 4-15; col 4, lns 10-13, 18-24; Abstract; Figs. 1, 6	1-20
Y	US 2006/0166819 A1 (POWERS et al.) 27 July 2006 (27.07.2006), para [0002], [0007], [0027], [0029]	1-20
Y	US 5,105,119 A (DAYTON) 14 April 1992 (14.04.1992), col 5, lns 12-15, 20-27; Fig. 1	11-20

 Further documents are listed in the continuation of Box C.

* Special categories of cited documents:

"A" document defining the general state of the art which is not considered to be of particular relevance

"E" earlier application or patent but published on or after the international filing date

"L" document which may throw doubts on priority claim(s) or which is cited to establish the publication date of another citation or other special reason (as specified)

"O" document referring to an oral disclosure, use, exhibition or other means

"P" document published prior to the international filing date but later than the priority date claimed

"T" later document published after the international filing date or priority date and not in conflict with the application but cited to understand the principle or theory underlying the invention

"X" document of particular relevance; the claimed invention cannot be considered novel or cannot be considered to involve an inventive step when the document is taken alone

"Y" document of particular relevance; the claimed invention cannot be considered to involve an inventive step when the document is combined with one or more other such documents, such combination being obvious to a person skilled in the art

"&" document member of the same patent family

Date of the actual completion of the international search

10 December 2009 (10.12.2009)

Date of mailing of the international search report

18 DEC 2009

Name and mailing address of the ISA/US

Mail Stop PCT, Attn: ISA/US, Commissioner for Patents
P.O. Box 1450, Alexandria, Virginia 22313-1450

Facsimile No. 571-273-3201

Authorized officer:

Lee W. Young

PCT Helpdesk: 571-272-4300
PCT OSP: 571-272-7774