



- (51) International Patent Classification:  
F02B 47/02 (2006.01)
- (21) International Application Number:  
PCT/US2011/044299
- (22) International Filing Date:  
17 July 2011 (17.07.2011)
- (25) Filing Language: English
- (26) Publication Language: English
- (30) Priority Data:  
12/878,816 9 September 2010 (09.09.2010) US
- (72) Inventor; and
- (71) Applicant : JUNG, Philip [US/US]; 5760 Vendome Drive North, Mobile, Alabama 36609 (US).
- (81) Designated States (unless otherwise indicated, for every kind of national protection available): AE, AG, AL, AM, AO, AT, AU, AZ, BA, BB, BG, BH, BR, BW, BY, BZ, CA, CH, CL, CN, CO, CR, CU, CZ, DE, DK, DM, DO, DZ, EC, EE, EG, ES, FI, GB, GD, GE, GH, GM, GT, HN,

HR, HU, ID, IL, IN, IS, JP, KE, KG, KM, KN, KP, KR, KZ, LA, LC, LK, LR, LS, LT, LU, LY, MA, MD, ME, MG, MK, MN, MW, MX, MY, MZ, NA, NG, NI, NO, NZ, OM, PE, PG, PH, PL, PT, RO, RS, RU, SC, SD, SE, SG, SK, SL, SM, ST, SV, SY, TH, TJ, TM, TN, TR, TT, TZ, UA, UG, US, UZ, VC, VN, ZA, ZM, ZW.

(84) Designated States (unless otherwise indicated, for every kind of regional protection available): ARIPO (BW, GH, GM, KE, LR, LS, MW, MZ, NA, SD, SL, SZ, TZ, UG, ZM, ZW), Eurasian (AM, AZ, BY, KG, KZ, MD, RU, TJ, TM), European (AL, AT, BE, BG, CH, CY, CZ, DE, DK, EE, ES, FI, FR, GB, GR, HR, HU, IE, IS, IT, LT, LU, LV, MC, MK, MT, NL, NO, PL, PT, RO, RS, SE, SI, SK, SM, TR), OAPI (BF, BJ, CF, CG, CI, CM, GA, GN, GQ, GW, ML, MR, NE, SN, TD, TG).

Published:  
— with international search report (Art. 21(3))  
(88) Date of publication of the international search report:  
27 March 2014

(54) Title: HIGH EFFICIENCY EIGHT STROKE INTERNAL COMBUSTION ENGINE

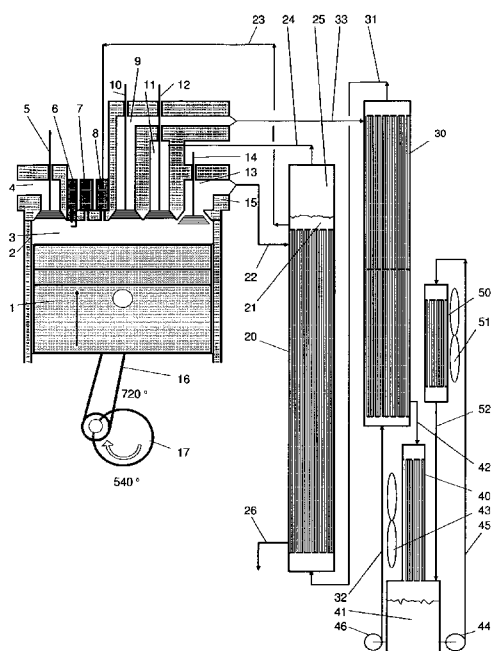

(57) Abstract: A method and a system for operating an eight-stroke internal combustion engine having higher thermal efficiency than a four-stroke engine is disclosed. The strokes comprise intake (FIG 1), compression (FIG 2), combustion for a first power stroke (FIG 3), exhaust (FIG 4), vapor or water injection for a second power stroke (FIG 5), vapor exhaust (FIG 6), vapor injection for a third power stroke (FIG 7), and vapor exhaust (FIG 8). Heat from each exhaust stroke is recovered and recycled to a subsequent stroke. Consequently, an engine with much higher thermal efficiency and thus lower fuel consumption is achieved.

WO 2012/033567 A3

<b>INTERNATIONAL SEARCH REPORT</b>		International application No. PCT/US11/44299			
<b>A. CLASSIFICATION OF SUBJECT MATTER</b> IPC: <b>F02B 47/02( 2006.01)</b>  USPC: 123/25C,25P According to International Patent Classification (IPC) or to both national classification and IPC					
<b>B. FIELDS SEARCHED</b>					
Minimum documentation searched (classification system followed by classification symbols) U.S. : 123/25C, 25P, 64; 60/712					
Documentation searched other than minimum documentation to the extent that such documents are included in the fields searched					
Electronic data base consulted during the international search (name of data base and, where practicable, search terms used) Please See Continuation Sheet					
<b>C. DOCUMENTS CONSIDERED TO BE RELEVANT</b>					
Category *	Citation of document, with indication, where appropriate, of the relevant passages	Relevant to claim No.			
A	US 4,736,715 (LARSEN) 12 April 1988 (12.04.1988), entire document.	1-18			
A	US 4,143,518 (KELLOGG-SMITH) 13 March 1979 (13.03.1979), entire document.	1-18			
<input type="checkbox"/> Further documents are listed in the continuation of Box C. <input type="checkbox"/> See patent family annex.					
* Special categories of cited documents: <table border="0" style="width: 100%;"> <tr> <td style="width: 33%; vertical-align: top;">           "A" document defining the general state of the art which is not considered to be of particular relevance            "E" earlier application or patent published on or after the international filing date            "L" document which may throw doubts on priority claim(s) or which is cited to establish the publication date of another citation or other special reason (as specified)            "O" document referring to an oral disclosure, use, exhibition or other means            "P" document published prior to the international filing date but later than the priority date claimed         </td> <td style="width: 33%; vertical-align: top;">           "T" later document published after the international filing date or priority date and not in conflict with the application but cited to understand the principle or theory underlying the invention            "X" document of particular relevance; the claimed invention cannot be considered novel or cannot be considered to involve an inventive step when the document is taken alone            "Y" document of particular relevance; the claimed invention cannot be considered to involve an inventive step when the document is combined with one or more other such documents, such combination being obvious to a person skilled in the art            "&amp;" document member of the same patent family         </td> <td style="width: 33%;"></td> </tr> </table>			"A" document defining the general state of the art which is not considered to be of particular relevance "E" earlier application or patent published on or after the international filing date "L" document which may throw doubts on priority claim(s) or which is cited to establish the publication date of another citation or other special reason (as specified) "O" document referring to an oral disclosure, use, exhibition or other means "P" document published prior to the international filing date but later than the priority date claimed	"T" later document published after the international filing date or priority date and not in conflict with the application but cited to understand the principle or theory underlying the invention "X" document of particular relevance; the claimed invention cannot be considered novel or cannot be considered to involve an inventive step when the document is taken alone "Y" document of particular relevance; the claimed invention cannot be considered to involve an inventive step when the document is combined with one or more other such documents, such combination being obvious to a person skilled in the art "&" document member of the same patent family	
"A" document defining the general state of the art which is not considered to be of particular relevance "E" earlier application or patent published on or after the international filing date "L" document which may throw doubts on priority claim(s) or which is cited to establish the publication date of another citation or other special reason (as specified) "O" document referring to an oral disclosure, use, exhibition or other means "P" document published prior to the international filing date but later than the priority date claimed	"T" later document published after the international filing date or priority date and not in conflict with the application but cited to understand the principle or theory underlying the invention "X" document of particular relevance; the claimed invention cannot be considered novel or cannot be considered to involve an inventive step when the document is taken alone "Y" document of particular relevance; the claimed invention cannot be considered to involve an inventive step when the document is combined with one or more other such documents, such combination being obvious to a person skilled in the art "&" document member of the same patent family				
Date of the actual completion of the international search 23 February 2012 (23.02.2012)		Date of mailing of the international search report <b>27 FEB 2012</b>			
Name and mailing address of the ISA/US Mail Stop PCT, Attn: ISA/US Commissioner for Patents P.O. Box 1450 Alexandria, Virginia 22313-1450 Facsimile No. (571) 273-3201		Authorized officer Linda Sholl Telephone No. (571) 272-4391			

**INTERNATIONAL SEARCH REPORT**

International application No.

PCT/US11/44299

**Box No. II Observations where certain claims were found unsearchable (Continuation of item 2 of first sheet)**

This international search report has not been established in respect of certain claims under Article 17(2)(a) for the following reasons:

1.  Claims Nos.:  
because they relate to subject matter not required to be searched by this Authority, namely:
  
2.  Claims Nos.:  
because they relate to parts of the international application that do not comply with the prescribed requirements to such an extent that no meaningful international search can be carried out, specifically:
  
3.  Claims Nos.:  
because they are dependent claims and are not drafted in accordance with the second and third sentences of Rule 6.4(a).

**Box No. III Observations where unity of invention is lacking (Continuation of item 3 of first sheet)**

This International Searching Authority found multiple inventions in this international application, as follows:

1.  As all required additional search fees were timely paid by the applicant, this international search report covers all searchable claims.
  2.  As all searchable claims could be searched without effort justifying additional fees, this Authority did not invite payment of any additional fees.
  3.  As only some of the required additional search fees were timely paid by the applicant, this international search report covers only those claims for which fees were paid, specifically claims Nos.:
  
  4.  No required additional search fees were timely paid by the applicant. Consequently, this international search report is restricted to the invention first mentioned in the claims; it is covered by claims Nos.:
- Remark on Protest**
- The additional search fees were accompanied by the applicant's protest and, where applicable, the payment of a protest fee.
  - The additional search fees were accompanied by the applicant's protest but the applicable protest fee was not paid within the time limit specified in the invitation.
  - No protest accompanied the payment of additional search fees.

**INTERNATIONAL SEARCH REPORT**

International application No.

PCT/US11/44299

Continuation of B. FIELDS SEARCHED Item 3:

EAST: US-PGPUB; USPAT; USOCR; FPRS; EPO; JPO; DERWENT; IBM\_TDB

Search Terms: eight, "8", stroke, cycle, engine, water, expan\$4, steam, combust\$4, burn\$4, inject\$4, vapor\$8, vapour\$8, power, expan\$9, fuel, meter\$4, admit\$6, cylinder, chamber