

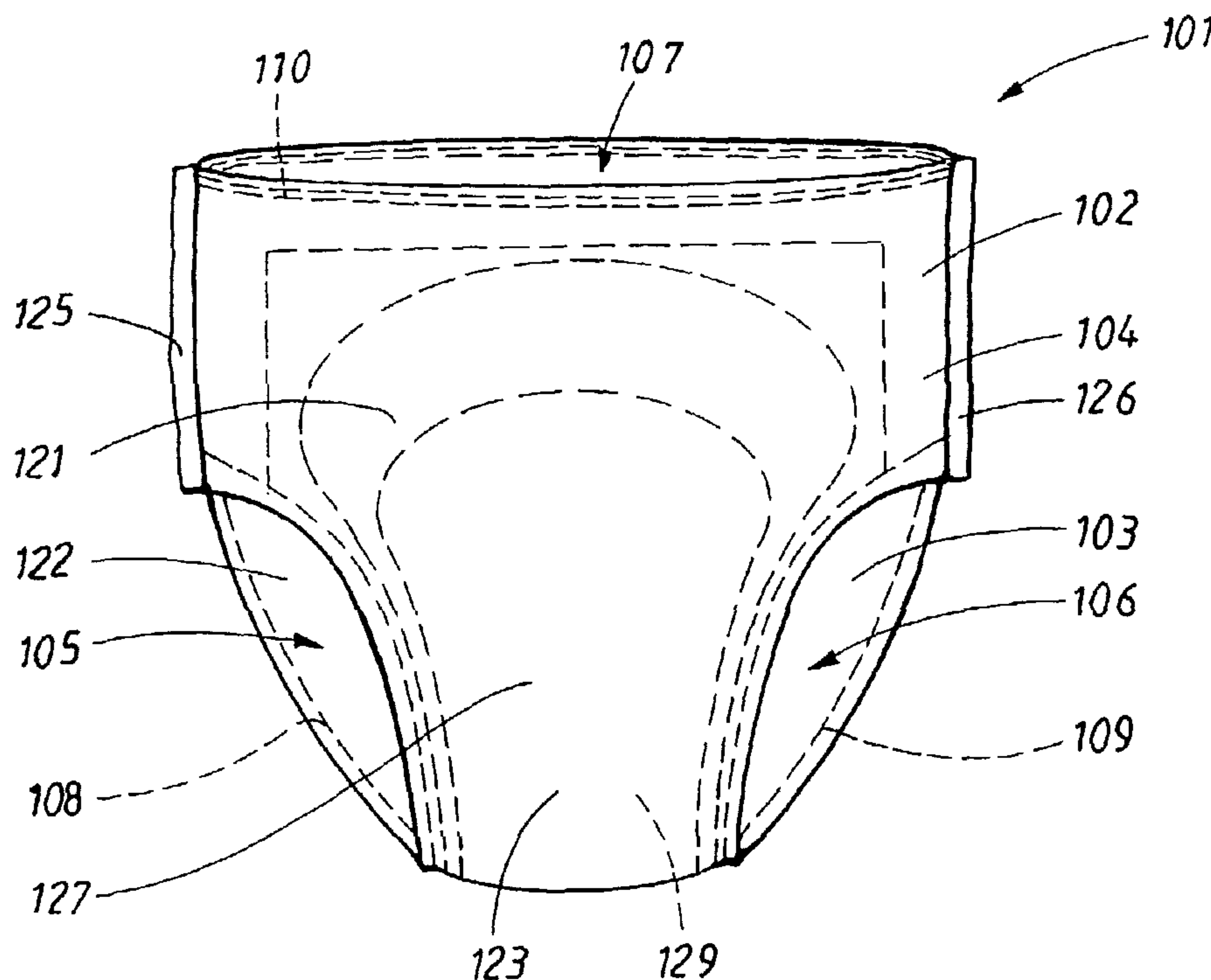

(86) Date de dépôt PCT/PCT Filing Date: 2003/02/07
 (87) Date publication PCT/PCT Publication Date: 2003/08/28
 (85) Entrée phase nationale/National Entry: 2004/07/08
 (86) N° demande PCT/PCT Application No.: SE 2003/000203
 (87) N° publication PCT/PCT Publication No.: 2003/070141
 (30) Priorité/Priority: 2002/02/19 (0200473-7) SE

(51) Cl.Int.⁷/Int.Cl.⁷ A61F 13/496
 (71) Demandeur/Applicant:
SCA HYGIENE PRODUCTS AB, SE
 (72) Inventeurs/Inventors:
HERMANSSON, KENT, SE;
LINNÉR, CATARINA, SE;
NORRBY, NICLAS, SE
 (74) Agent: FETHERSTONHAUGH & CO.

(54) Titre : COUCHES-CULOTTES ABSORBANTES ELASTIQUES
 (54) Title: ELASTIC ABSORBENT PANTS



(57) Abrégé/Abstract:

The invention relates to absorbent pants (101; 301), with a longitudinal direction and a transverse direction at right angles to the longitudinal direction and comprising an absorption core (129; 329) arranged between a liquid-tight cover sheet (128; 328) and a liquid-permeable cover sheet (130; 330). The diaper pants (101; 301) have a front portion (121; 321), a rear portion (122; 322) and an intermediate crotch portion (123; 323), and a front edge and a rear edge extending substantially in the transverse direction and forming a waist opening (107; 307), two side edges extending substantially in the longitudinal direction and forming two leg openings (105, 106; 305, 306). An elastic sheet material is arranged at least along the waist opening (107; 307) of the diaper pants (101; 301) and extends the whole way from the waist opening (107; 307) to the leg openings (105, 106; 305, 306), the elastic sheet material being secured to the absorption core (129, 329) in a substantially unstretched state.

(12) INTERNATIONAL APPLICATION PUBLISHED UNDER THE PATENT COOPERATION TREATY (PCT)

(19) World Intellectual Property Organization
International Bureau(43) International Publication Date
28 August 2003 (28.08.2003)

PCT

(10) International Publication Number
WO 03/070141 A1

- (51) International Patent Classification⁷: A61F 13/496
- (21) International Application Number: PCT/SE03/00203
- (22) International Filing Date: 7 February 2003 (07.02.2003)
- (25) Filing Language: Swedish
- (26) Publication Language: English
- (30) Priority Data:
0200473-7 19 February 2002 (19.02.2002) SE
- (71) Applicant: SCA HYGIENE PRODUCTS AB [SE/SE];
S-405 03 Göteborg (SE).
- (72) Inventors: HERMANSSON, Kent; Citrusgatan 7, S-426
54 Västra Frölunda (SE). CRAFOORD, Catarina;
Slottskogsgatan 51A, S-414 70 Göteborg (SE). NORRBY,
Niclas; Albert Engströmsgatan 21, S-412 73 Göteborg
(SE).
- (74) Agent: ALBIHNS GÖTEBORG AB; P.O. Box 142,
S-401 22 Göteborg (SE).
- (81) Designated States (*national*): AE, AG, AL, AM, AT, AU,
AZ, BA, BB, BG, BR, BY, BZ, CA, CH, CN, CO, CR, CU,
CZ, DE, DK, DM, DZ, EC, EE, ES, FI, GB, GD, GE, GH,
GM, HR, HU, ID, IL, IN, IS, JP, KE, KG, KP, KR, KZ, LC,
LK, LR, LS, LT, LU, LV, MA, MD, MG, MK, MN, MW,
MX, MZ, NO, NZ, OM, PH, PL, PT, RO, RU, SC, SD, SE,
SG, SK, SL, TJ, TM, TN, TR, TT, TZ, UA, UG, UZ, VC,
VN, YU, ZA, ZM, ZW.
- (84) Designated States (*regional*): ARIPO patent (GH, GM,
KE, LS, MW, MZ, SD, SL, SZ, TZ, UG, ZM, ZW),
Eurasian patent (AM, AZ, BY, KG, KZ, MD, RU, TJ, TM),
European patent (AT, BE, BG, CH, CY, CZ, DE, DK, EE,
ES, FI, FR, GB, GR, HU, IE, IT, LU, MC, NL, PT, SE, SI,
SK, TR), OAPI patent (BF, BJ, CF, CG, CI, CM, GA, GN,
GQ, GW, ML, MR, NE, SN, TD, TG).

Declaration under Rule 4.17:

- as to the identity of the inventor (Rule 4.17(i)) for the following designations AE, AG, AL, AM, AT, AU, AZ, BA, BB, BG, BR, BY, BZ, CA, CH, CN, CO, CR, CU, CZ, DE, DK, DM, DZ, EC, EE, ES, FI, GB, GD, GE, GH, GM, HR, HU, ID, IL, IN, IS, JP, KE, KG, KP, KR, KZ, LC, LK, LR, LS, LT, LU, LV, MA, MD, MG, MK, MN, MW, MX, MZ, NO, NZ,

[Continued on next page]

(54) Title: ELASTIC ABSORBENT PANTS

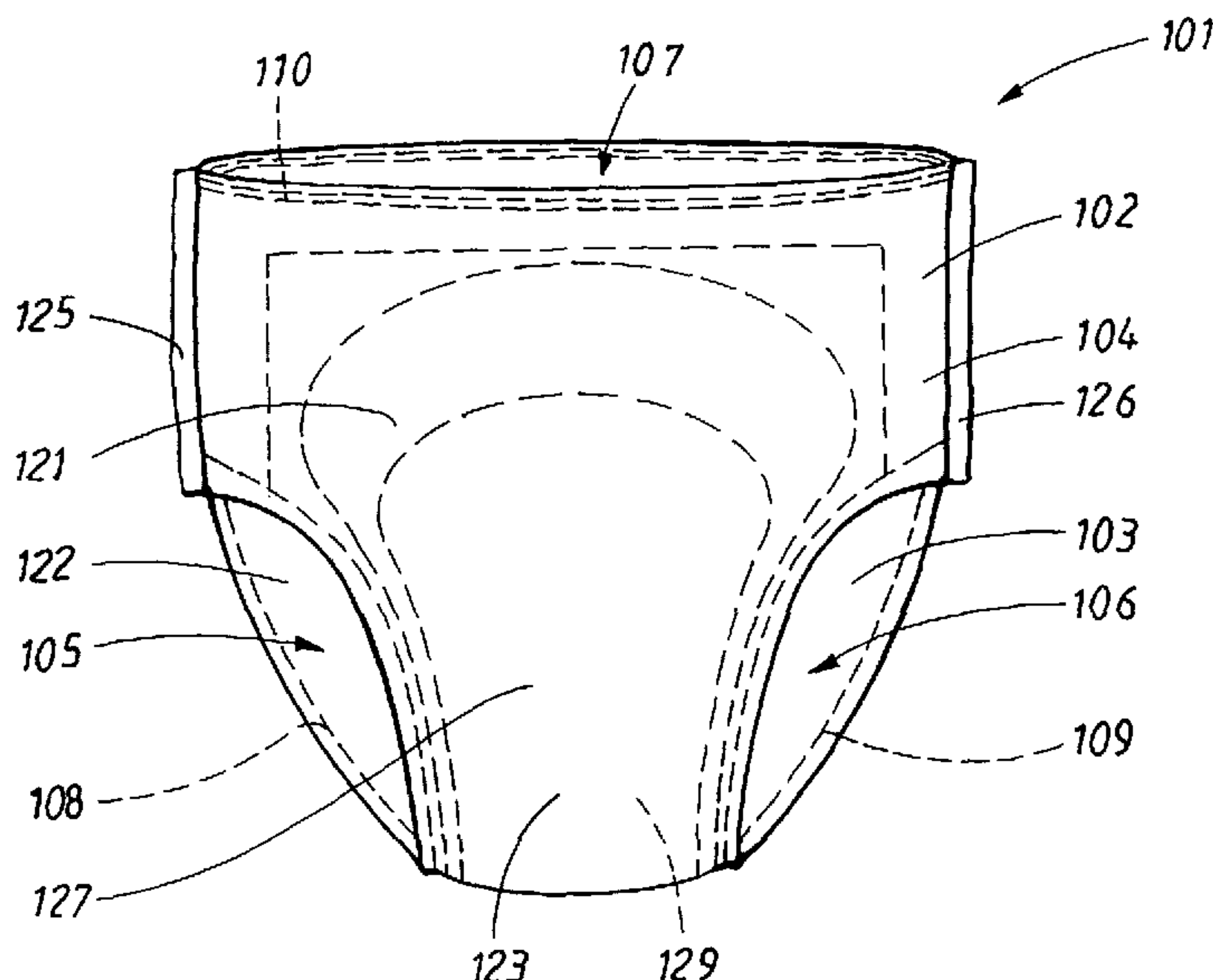

(57) **Abstract:** The invention relates to absorbent pants (101; 301), with a longitudinal direction and a transverse direction at right angles to the longitudinal direction and comprising an absorption core (129; 329) arranged between a liquid-tight cover sheet (128; 328) and a liquid-permeable cover sheet (130; 330). The diaper pants (101; 301) have a front portion (121; 321), a rear portion (122; 322) and an intermediate crotch portion (123; 323), and a front edge and a rear edge extending substantially in the transverse direction and forming a waist opening (107; 307), two side edges extending substantially in the longitudinal direction and forming two leg openings (105, 106; 305, 306). An elastic sheet material is arranged at least along the waist opening (107; 307) of the diaper pants (101; 301) and extends the whole way from the waist opening (107; 307) to the leg openings (105, 106; 305, 306), the elastic sheet material being secured to the absorption core (129, 329) in a substantially unstretched state.



WO 03/070141 A1

WO 03/070141 A1

OM, PH, PL, PT, RO, RU, SC, SD, SE, SG, SK, SL, TJ, TM, TN, TR, TT, TZ, UA, UG, UZ, VC, VN, YU, ZA, ZM, ZW, ARIPO patent (GH, GM, KE, LS, MW, MZ, SD, SL, SZ, TZ, UG, ZM, ZW), Eurasian patent (AM, AZ, BY, KG, KZ, MD, RU, TJ, TM), European patent (AT, BE, BG, CH, CY, CZ, DE, DK, EE, ES, FI, FR, GB, GR, HU, IE, IT, LU, MC, NL, PT, SE, SI, SK, TR), OAPI patent (BF, BJ, CF, CG, CI, CM, GA, GN, GQ, GW, ML, MR, NE, SN, TD, TG)

Published:

— with international search report

For two-letter codes and other abbreviations, refer to the "Guidance Notes on Codes and Abbreviations" appearing at the beginning of each regular issue of the PCT Gazette.

TITLE

Elastic absorbent pants

5 TECHNICAL FIELD

The invention relates to diaper pants, with a longitudinal direction and a transverse direction at right angles to the longitudinal direction and comprising an absorption core arranged between a liquid-tight cover sheet
10 and a liquid-permeable cover sheet, the absorbent pants having a front portion, a rear portion and an intermediate crotch portion, a front edge and a rear edge extending substantially in the transverse direction and forming a waist opening having an unextended circumference and an extended circumference, two side edges extending substantially in the longitudinal
15 direction and forming two leg openings.

BACKGROUND

The main components in diaper pants are usually an absorption core which is
20 arranged between two cover sheets, one of which is a liquid barrier sheet, for example a plastic film, and the other a liquid-permeable cover sheet, for example a nonwoven sheet. Further components, such as inner barriers, for example raised edge barriers, arranged in connection with the liquid-permeable cover sheet, or textile-like outer covers arranged outside the liquid
25 barrier sheet can also be present. The absorbent pants are designed with a front portion which, during use, is directed forwards on the user and lies across the latter's groin area, a rear portion which, during use, is directed rearwards on the user and lies across the latter's buttocks, and a crotch portion which is arranged between the front portion and the rear portion and
30 is intended to be positioned at the user's crotch. The front portion, the rear portion and the crotch portion together form absorbent pants or briefs with two leg openings and a waist opening. The absorption core is usually

arranged substantially centrally between the leg openings and extends at least over the crotch portion. The portions of the absorbent pants which, during use, are arranged across the user's hips are generally free from absorption material. These portions consist, for example, of parts of one or
5 both of the cover sheets, of a separate outer cover, or of separate material pieces usually called side panels.

In order to ensure that the absorbent pants will fit a user's body shape and body size like an article of clothing, and in order to form closure seals
10 preventing leakage around the leg openings and the waist openings, the absorbent pants are generally also provided with elastic members in the form of elastic threads or bands. The elastic threads and bands are generally secured, in a continuous process and in the stretched state, to one or more
15 components of the absorbent pants, generally to at least one cover sheet. By means of securing stretched elastic members, for example to a cover sheet, it is possible also to give a nonelastic material sheet elastic properties. The elastic members are kept stretched during production of the known diaper pants. When the individual diaper pants are cut out from a continuous
20 production web, the stretching of the elastic members ceases and they are able to gather together into their unstretched state. In doing so, the components secured to the elastic members are also gathered together. This means that the finished absorbent pants have a creased appearance, at least in the areas around the elastic members. In addition, the elastic members give the absorbent pants a three-dimensional form which makes them difficult
25 to fold and package.

In order to achieve a good fit of the known diaper pants and to allow the diaper pants to be used by persons with different body shapes and body sizes, the diaper pants are often provided with a large number of elastic
30 members which run parallel across the front and rear portions of the absorbent pants. Although such an arrangement functions fairly well from the technical point of view, the many elastic members give the known diaper

pants a particularly creased and baggy appearance. This is a negative factor for various reasons. The greatest disadvantage is that it is difficult to conceal diaper pants of this kind under normal clothes, which can be very embarrassing, especially for adult users of diaper pants. The creased appearance also strengthens the immediate impression that the absorbent article is in fact a diaper, which is perceived as a negative factor by adult incontinence sufferers. It is therefore desirable to produce diaper pants which are perceived and appear more as underpants than as a diaper. Another disadvantage of using the creased diaper pants is that folds and creases can cause discomfort in the form of chafing and irritation of the user's skin.

A way of achieving an improved fit and of avoiding the use of a large number of stretched elastic members is to make the side panels of diaper pants from elastic material, for example elastic nonwoven, or elastic laminate. However, the main problem of the diaper pants with elastic side panels which have hitherto been proposed is that they are complicated to produce because they necessitate the handling of separate elastic material pieces at high production speeds. Moreover, with elastic side panels, it is possible only to obtain limited size fit and shape fit of the diaper pants because large parts of the front portion and rear portion of the absorbent pants remain nonelastic.

There is therefore a great need for absorbent diaper pants which are comfortable to wear, sit securely in place and can be concealed under normal clothes.

DISCLOSURE OF THE INVENTION

In accordance with the invention, elastic diaper pants of the type mentioned at the outset have been obtained which substantially eliminate the disadvantages of previously known diaper pants of this kind. Diaper pants according to the invention are mainly distinguished by the fact that they comprise an elastic sheet material which is arranged at least along the waist

opening of the absorbent pants and extends the whole way from the waist opening to the leg openings, the elastic sheet material being secured to the absorption core in a substantially unstretched state.

5 Diaper pants according to the invention are thus made of material which has been joined together while in a substantially unstretched, tension-free state, i.e. with only a slight degree of elastic tensioning. An elastic material in a substantially unstretched state is here understood as meaning that the material is stretched not more than 5% from its completely unstretched state.
10 This means that the finished diaper pants are smooth and have a substantially plane shape. Diaper pants according to the invention thus have an aesthetically pleasing appearance, are comfortable and discreet to wear, and are considerably easier to fold and package than previously known diaper pants with creased and three-dimensionally curved portions.

15

The elastic parts of diaper pants according to the invention are activated when the absorbent pants are put on. The elastic portions are stretched out so that the absorbent pants can fit onto a user's body. The size of the absorbent pants is such that the elastic portions are kept stretched during
20 use and thus seek to draw together to their unstressed state, by which means the absorbent pants are maintained on the user's body. According to a preferred embodiment, the elastic sheet material is elastically extensible in more than one direction, which is advantageous with respect to the fit of the absorbent pants.

25

It has been found that, for absorbent pants to be able to be put on and taken off easily and comfortably, the extensibility must be sufficient to allow the pants to be stretched out across the user's hips. The extensibility should be such that the pants can be stretched past the hips and such that they can be
30 pulled up over the hips simply by gripping the pants at the waist edge. In absorbent pants which can be put on easily and comfortably, the extensibility of the elastic sheet material should be at least 80% in the transverse

direction of the absorbent pants and preferably at least 100% in the transverse direction of the absorbent pants.

5 As regards the fit of the absorbent pants, it is also advantageous if the extensibility of the elastic sheet material in the longitudinal direction of the absorbent pants, i.e. in a direction parallel to a line between the rear edge and the front edge of the absorbent pants, is at least 80% and preferably at least 100%.

10 Elastic extensibility here refers to the lengthening in the direction of extension which the material permits without plastically deforming or bursting. If a material is to be considered as being elastically extensible, it is also necessary for the material, when extension ceases, to gather together and seek to recover its original extent in the direction of extension. A fully elastic
15 material returns completely to the unextended state, while a less elastic material remains slightly stretched even when the stretching force ceases. For the purposes of the invention, it is expedient that the elastic material web can return to an extent which is at most 150% of the unstretched material web and preferably at most 120% thereof.

20

The elastic sheet material can advantageously be arranged in the form of outer pants which support the absorption core. Such an embodiment affords diaper pants which have an extremely good fit.

25 In order to further improve the fit and the leaktightness of diaper pants according to the invention, elastic members can be arranged around the waist opening and thus form waist elastic.

30 Correspondingly, elastic members can be arranged around the leg openings and form leg elastic which, during use of the absorbent pants, fits round the user's legs. In addition to contributing to an improved fit and increased

leaktightness, leg elastic and waist elastic give the absorbent pants an appearance more like briefs.

5 The elastic members in the waist elastic and leg elastic are preferably arranged on the absorbent pants in a substantially unstretched state and expediently with a degree of extensibility of at most 10% and preferably at most 5%.

10 On application of elastic members with low prestressing, or no prestressing, it is important that the elastic members are secured in such a way that the elasticity in the elastic members is not inhibited. This can be done, for example, by using an elastic adhesive, by gluing in a stretchable pattern along the elastic members, or by intermittent welding. Examples of stretchable adhesive patterns are spot gluing, spray gluing, and adhesive
15 applied in the form of adhesive strands arranged across the elastic members.

In order to ensure that the absorbent pants are maintained in the correct position on the user's body and do not slip down across the user's hips even when they have absorbed a large amount of bodily excretions, the absorbent
20 pants should be able to support a weight of at least 200 g (ca. 2 N) when the absorbent pants are intended for persons with mild incontinence. Persons suffering from what is generally called mild incontinence are only urine-incontinent and are generally able to change their incontinence protection as soon as the opportunity arises after urination. By contrast, persons with
25 severe incontinence are often not able to determine when the bladder has emptied and are therefore often not in a position to change their incontinence protector. In addition, severe incontinence quite often involves a combination of urinary incontinence and fecal incontinence, which means that considerably greater amounts of bodily excretions generally have to be
30 retained in an incontinence protector for severely incontinent persons. Such an incontinence protector should therefore be able to support a weight of 1000 g (ca. 10 N).

According to one embodiment of the invention, the absorbent pants comprise a core pack comprising a liquid barrier sheet, an absorption core and a liquid-permeable inner sheet, said core pack being secured with the liquid barrier sheet towards the elastic sheet material.

According to another embodiment of the invention, the absorption core is arranged between an elastic liquid-permeable inner sheet and an elastic barrier sheet.

10

DESCRIPTION OF THE FIGURES

The invention will be described in greater detail below with reference to the figures in the attached drawings, in which:

15

Figure 1 shows diaper pants according to a first embodiment of the invention and comprising a core pack,

Figure 2 shows the core pack in Figure 1, and

20

Figure 3 shows diaper pants according to a second embodiment of the invention.

DESCRIPTION OF EMBODIMENTS

25

The diaper pants 101 shown in Figure 1 comprise elastically extensible outer pants 102 which are formed by an inner elastic material sheet 103 and an outer elastic material sheet 104 which are connected to each other, for example by adhesive bonding or by welding with heat or ultrasound. Suitable elastic material sheets are different types of elastic nonwoven material. As has previously been mentioned, an elastic nonwoven material suitable for use in absorbent pants according to the invention should be able to be

30

stretched elastically at least 80% and preferably at least 100% in the transverse direction of the pants so that the waist opening (see below) of the pants can be widened sufficiently for the pants to be able to be pulled up across the user's hips in a convenient way. It is also advantageous if the
5 elastic nonwoven material can also be stretched elastically in the longitudinal direction of the absorbent pants, i.e. in a direction at right angles to the transverse direction.

The material sheets included in the outer pants 102 can further consist of
10 laminates. In addition, it is of course possible to use more than two sheets to form the outer pants.

The outer pants 102 have two leg openings 105, 106, and a waist opening 107 which extends in the transverse direction of the diaper pants and is
15 formed by a front waist edge which, when the diaper pants are in use, is arranged over the user's stomach, and a rear waist edge which, during use, is arranged across the user's back.

Elastic members are arranged as leg elastic 108, 109 around the leg
20 openings 105, 106 and as waist elastic 110 around the waist opening 107. In the illustrative embodiment shown, the elastic members 108, 109, 110 are secured between the two elastic material sheets 103, 104. However, it is possible, within the scope of the invention, to form the outer pants from just one material sheet and in this case to secure any elastic members around
25 leg openings and waist opening only to this material sheet.

The outer pants 102 are designed with a front portion 121 which, during use, is directed forwards on the user and lies across the latter's stomach, a rear portion 122 which, during use, is directed rearwards on the user and lies
30 across the latter's buttocks, and a narrower intermediate crotch portion 123 which, during use, is arranged between the user's legs. The outer pants 102 also have two side seams 125, 126 which connect the front portion 121 to the

rear portion 122 between the waist opening 107 and the leg openings 105, 106 and which, during use of the diaper pants 101, are intended to be arranged across the user's hips.

5 A core pack 127 is secured inside the elastically extensible outer pants 102. The core pack 127 can be secured to the outer pants 102 across the whole of the common surface, or only over parts thereof. For example, the core pack 127 can be secured only along a line or a band-shaped area extending centrally across the diaper pants 101 from the front portion 121 to the rear
10 portion 122. Alternatively, the core pack can be secured along one or more transverse lines or band-shaped areas. For example, it may be expedient to secure the core pack within a transverse attachment area in the crotch portion 123 of the diaper pants. It is also possible to secure the core pack 127 via a number of attachment points or attachment areas. The core pack
15 127 should be sufficiently well secured inside the outer pants 102 to ensure that it does not come loose or move out of position during use. However, it is advantageous if the core pack 127 has a certain mobility in relation to the outer pants 102, since this means that the elastic extensibility of the outer pants 102 can be better used if the extension is limited as little as possible by
20 the core pack 127.

The core pack 127 is shown best in Figure 2 and comprises a liquid barrier sheet 128, an absorption core 129, and a liquid-permeable inner sheet 130. The core pack 127 is secured with the liquid barrier sheet 128 towards the
25 inner elastic material sheet 103. Figures 1 and 2 show an absorption core 129 consisting of two absorption sheets 131, 132 laid one upon the other, the lower absorption sheet 131 located nearest to the liquid barrier sheet 128 being slightly larger than the upper absorption sheet 132 located nearest to the inner sheet 130. In the example shown, the core pack 127 has an angular
30 hourglass shape in the plane, the plane form of the core pack being defined by the shape of the liquid barrier sheet 128 and the liquid-permeable inner sheet 130, which together enclose the absorption core 129. It is of course

possible to use the core pack 127 with another plane shape, for example the liquid barrier sheet 128 and the inner sheet 130 can have a more rounded hourglass shape, a rectangular shape, a trapezoidal shape, an oval shape, etc. Nor does the core pack need to be the size shown in the figure. For
5 example, in the case of absorbent pants intended as protection for mild incontinence or as sanitary towels, it may be sufficient to have an absorption core 129 which is positioned mainly in the crotch portion 123 of the absorbent pants.

10 The liquid-permeable inner sheet 130 can consist of any material known for the purpose, such as a layer of nonwoven material, a perforated plastic film, net material, tow, or the like. The inner sheet 130 can of course also consist of a laminate of two or more sheets of the same or different material.

15 The liquid barrier sheet 128 can consist of a liquid-tight plastic film, a hydrophobic nonwoven sheet, or a nonwoven sheet which has been treated to give it liquid barrier properties, or some other flexible material sheet which has the ability to withstand liquid penetration. However, it can be advantageous if the liquid barrier sheet 128 has a certain breathability, i.e.
20 permits the passage of water vapour through the sheet 128.

The absorption core 129 can be made up of absorbent material, such as cellulose fluff pulp, tissue, absorbent foam, etc. It is also possible for the absorption core to contain superabsorbents, i.e. polymer materials which are
25 able to absorb body fluid corresponding to many times their own weight and form a hydrogel. Such superabsorbents are usually present in the form of particles, but fibres, flakes, granules and films are also available. Moreover, the absorption core 129 can comprise nonabsorbent components such as stiffening elements, shaping elements, binders, etc. Various types of liquid-
30 receiving and liquid-distributing structures such as fibre wads, open-cell foam, spreading sheets or the like can also be included in the core pack 127.

The various components included in the core pack 127 can be connected to one another in a conventional manner, for example by adhesive bonding, or by welding with heat or ultrasound. The core pack 127 can of course contain further components in addition to those described here, for example the core
5 pack can comprise a liquid transport sheets, elastic members, shape-stabilizing members, shaping elements or the like. Although the absorption core has been shown with two absorption sheets 131, 132, alternative configurations can be used. For example, a single absorption sheet may be sufficient for certain applications, while other applications may require more
10 than two absorption sheets. The configuration of the absorption core can thus be adapted to the amount of liquid which the absorption core is expected to absorb. Likewise, as regards the size and nature of the absorption core, it is of course important which type of bodily excretions are to be absorbed and in which way the bodily excretions are discharged to the absorption core.

15

Figure 3 shows diaper pants 301 which, like the diaper pants in Figure 1, comprise elastically extensible outer pants 302 which are formed by an inner elastic material sheet 303 and an outer elastic material sheet 304. The outer elastic material sheet 304 in this case constitutes a textile outer sheet of the
20 diaper pants 301, and the inner elastic material sheet constitutes the liquid barrier sheet 328 in the diaper pants 301 and prevents liquid from leaking out from the diaper pants 301 during use. The outer pants 302 also include elastic members 308, 309 which are arranged around the leg openings 305, 306 of the diaper pants and which are secured between the textile outer sheet 304 of the outer pants 302 and the liquid barrier sheet 328. The textile
25 outer sheet 304 expediently consists of elastic nonwoven material.

The liquid barrier sheet 328 consists of an elastic liquid-tight plastic film, an elastic liquid-tight nonwoven material or the like.

30

In the same way as the diaper pants 101 shown in Figure 1, the outer pants 302 are designed with a front portion 321, a rear portion 322 and a narrower

crotch portion 323 lying between these. The outer pants 302 also have two side seams 325, 326 which connect the front portion 321 to the rear portion 322 between the waist opening 307 and the leg openings 305, 306 and which, during use of the diaper pants 301, are intended to be arranged
5 across the user's hips.

An absorption core 329 is secured inside the elastically extensible outer pants 302. The absorption core 329 is secured to the liquid barrier sheet 328 of the outer pants 302, for example by adhesive bonding. The absorption
10 core 329 comprises a first liquid collection sheet 331 arranged nearest to the liquid barrier sheet 328, and a second liquid-receiving sheet 332 arranged between the liquid collection sheet 331 and a liquid-permeable inner sheet. The liquid-permeable inner sheet 330 can be a liquid-permeable nonwoven material, a perforated plastic film, a net material, or the like. The liquid-
15 permeable inner sheet 330 can be elastic or nonelastic. In the illustrative embodiment shown, the inner sheet 330 extends across the whole of the inner side of the diaper pants and thus forms a textile inner sheet against the user's skin. In such an embodiment, the inner sheet is elastic. When using a nonelastic inner sheet, the latter is applied only over a smaller surface of the
20 outer pants 302, so that the absorption core 329 is covered, with minimal adverse effect on the elasticity of the outer pants 302.

Although the absorption core 329 has been shown as a two-sheet structure, it is of course possible, in the same way as in the diaper pants shown in
25 Figure 1, to use other types of absorption bodies.

Absorption bodies in absorbent articles for taking up body fluids usually consist of fibre sheets, for example of cellulose fluff pulp. It is also possible to use fibre sheets which have been bonded together with a binder, for example
30 thermofibres. It is also customary to use polymeric gel-forming absorption materials, called superabsorbents, which can be mixed with fibres or arranged on separate carrier sheets. The design of the absorption body 409,

like the choice of material, is of course dictated by the intended application and by the amount of liquid which the absorption body is expected to be able to absorb.

- 5 The invention is not to be regarded as being limited by the illustrative embodiments described above, and a number of further variants and modifications are possible within the scope of the invention.

PATENT CLAIMS

- 5 1. Diaper pants (101; 301), with a longitudinal direction and a transverse direction at right angles to the longitudinal direction and comprising an absorption core (129; 329) arranged between a liquid barrier sheet (128; 328) and a liquid-permeable inner sheet (130; 330), the absorbent pants (101; 301) having a front portion (121; 321), a rear portion (122; 322) and an intermediate crotch portion (123; 323), a front edge and a rear edge extending substantially in the transverse direction and forming a waist opening (107; 307) having an unextended circumference and an extended circumference, two side edges extending substantially in the longitudinal direction and forming two leg openings (105, 106; 305, 306), characterized in that the absorbent pants (101; 301) comprise an elastic sheet material which is arranged at least along the waist opening (107; 307) and extends the whole way from the waist opening (107; 307) to the leg openings (105, 106; 305, 306), the elastic sheet material being secured to the absorption core (129; 329) in a substantially unstretched state.
- 10
- 15
- 20
2. Diaper pants according to Claim 1, characterized in that the extensibility of the elastic sheet material is at least 80% in the transverse direction of the absorbent pants (101; 301), and the extended circumference of the waist opening (107; 307) is at least 80% greater than the unextended circumference.
- 25
3. Diaper pants according to Claim 1, characterized in that the extensibility of the elastic sheet material is at least 100% in the transverse direction of the absorbent pants (101; 301), and the extended circumference of the waist opening (107; 307) is at least 100% greater than the unextended circumference.
- 30

4. Absorbent pants according to any of Claims 1-3, characterized in that the elastic sheet material forms outer pants (102; 302) which support the absorption core (129; 329).
- 5 5. Diaper pants according to any of the preceding claims, characterized in that elastic members are arranged around the waist opening (107; 307) and form waist elastic (110; 310).
6. Diaper pants according to any of the preceding claims, characterized
10 in that elastic members are arranged around the leg openings (105, 106; 305, 306) and form leg elastic (108, 109; 308, 309).
7. Diaper pants according to either of Claims 5 and 6, characterized in
15 that the elastic members (108, 109, 110; 308, 309, 310) are arranged on the absorbent pants (101; 301) with an extension of at most 10%.
8. Absorbent pants according to any of the preceding claims,
characterized in that the absorbent pants can support a weight of
200g.
20
9. Absorbent pants according to any of the preceding claims,
characterized in that the absorbent pants can support a weight of
1000g.
- 25 10. Absorbent pants according to any of the preceding claims,
characterized in that the diaper pants (101) comprise a core pack
(127) comprising a liquid barrier sheet (128), an absorption core (129),
and a liquid-permeable inner sheet (130), said core pack (127) being
secured with the liquid barrier sheet (128) towards the elastic sheet
30 material.

11. Absorbent pants according to any of Claims 1-9, characterized in that the absorption core (329) is arranged between an elastic liquid-permeable inner sheet (330) and an elastic barrier sheet (328).

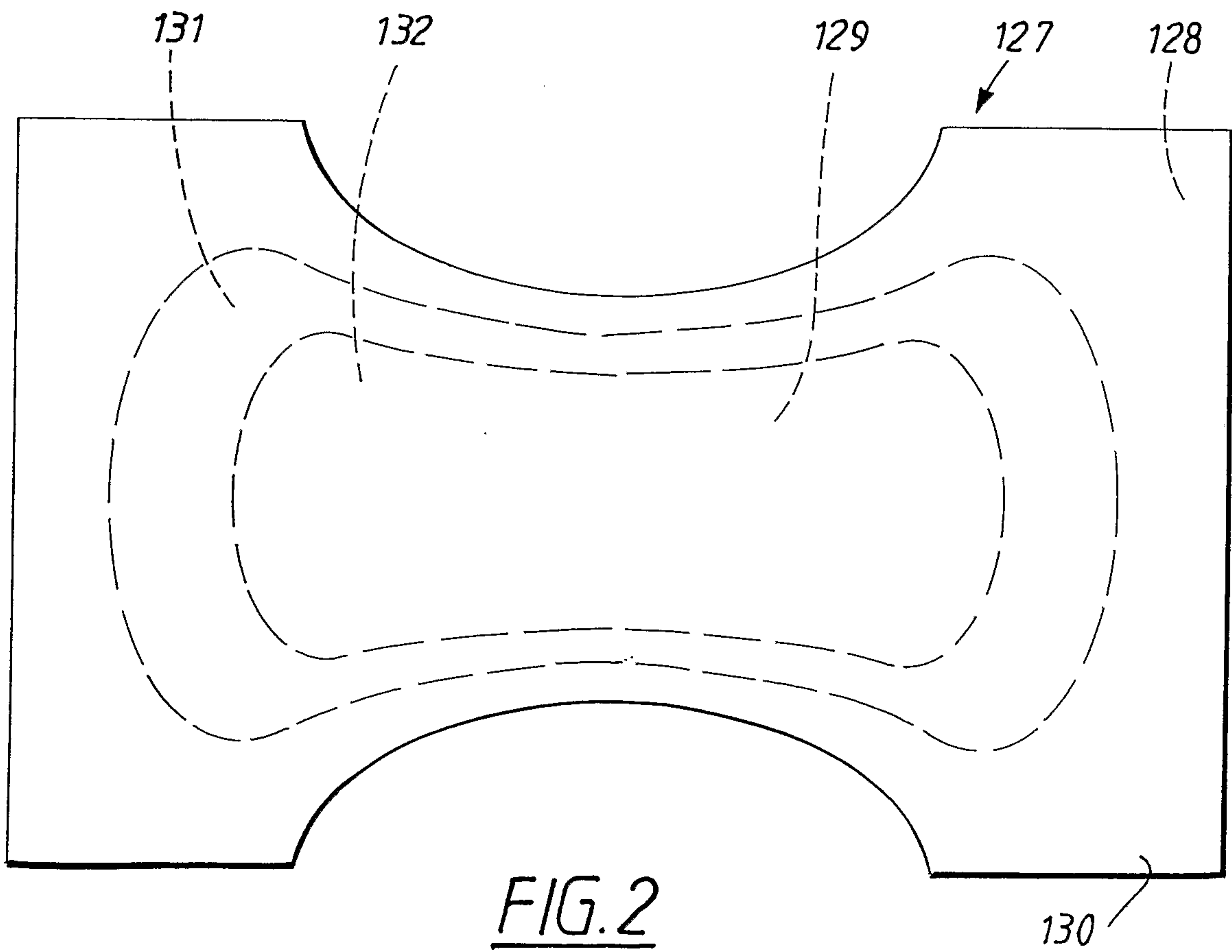
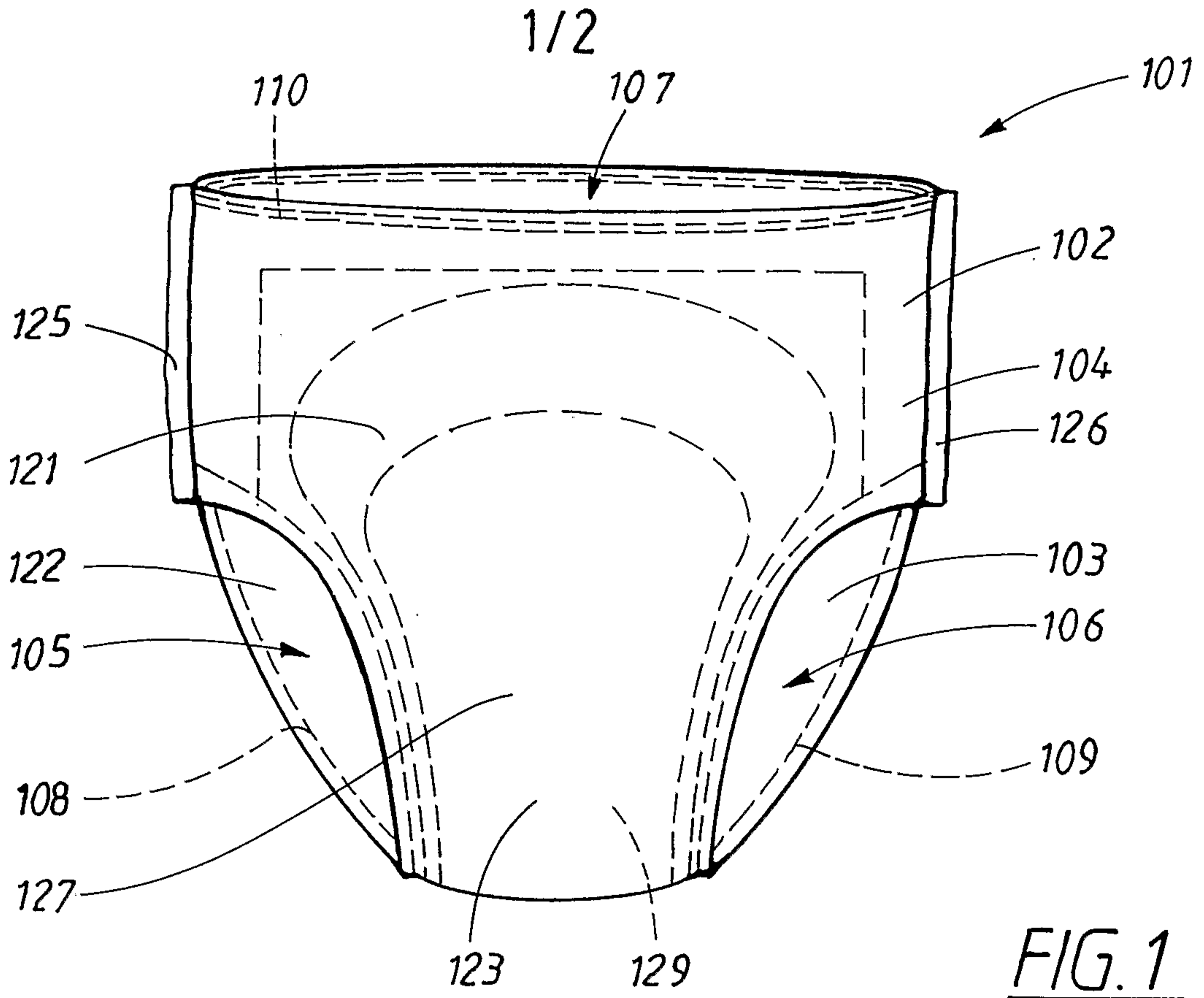

2/2

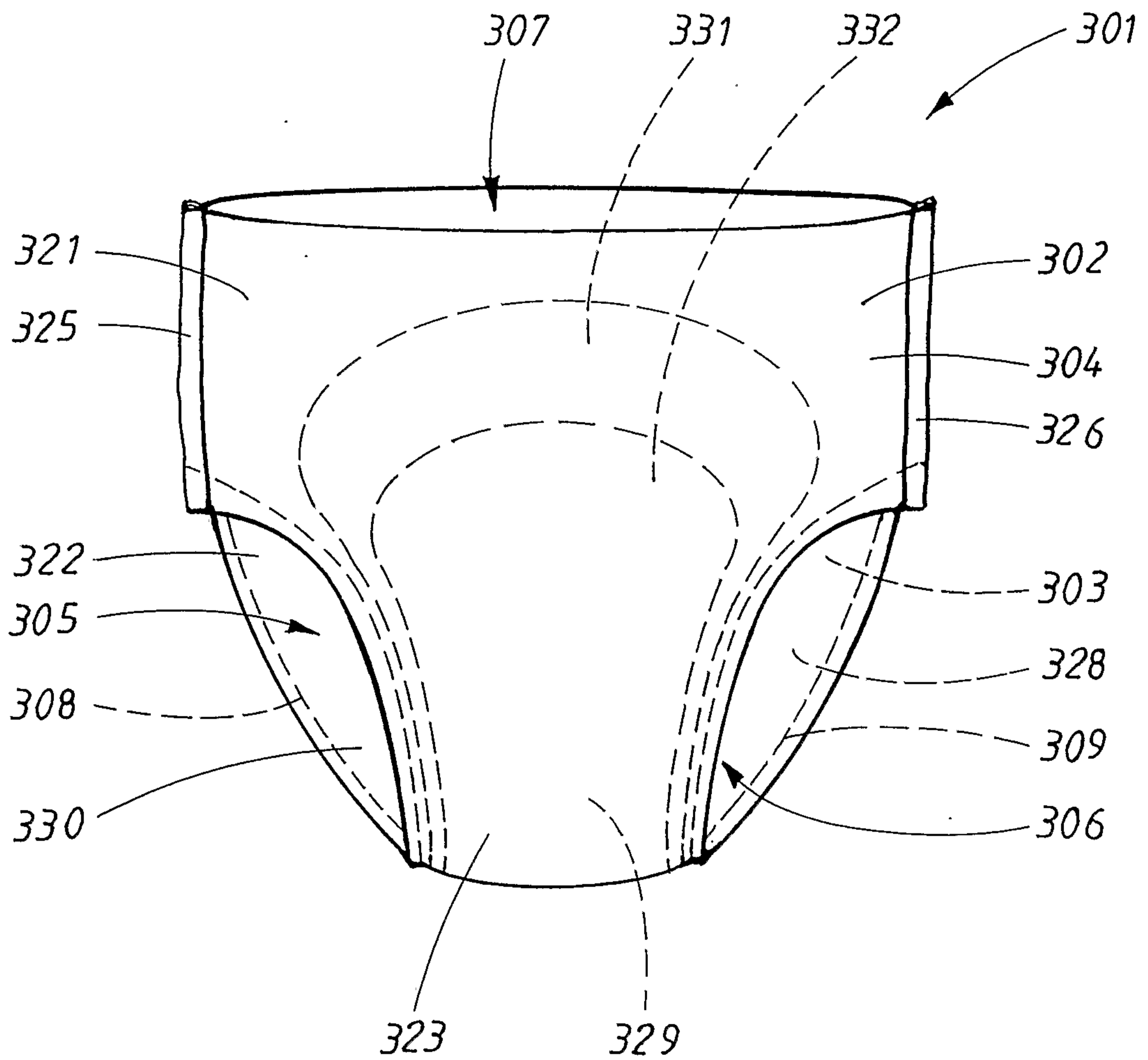

FIG. 3

