

T. GIRVAN.  
REDUCTION APPARATUS.

No. 522,590.

Patented July 10, 1894.

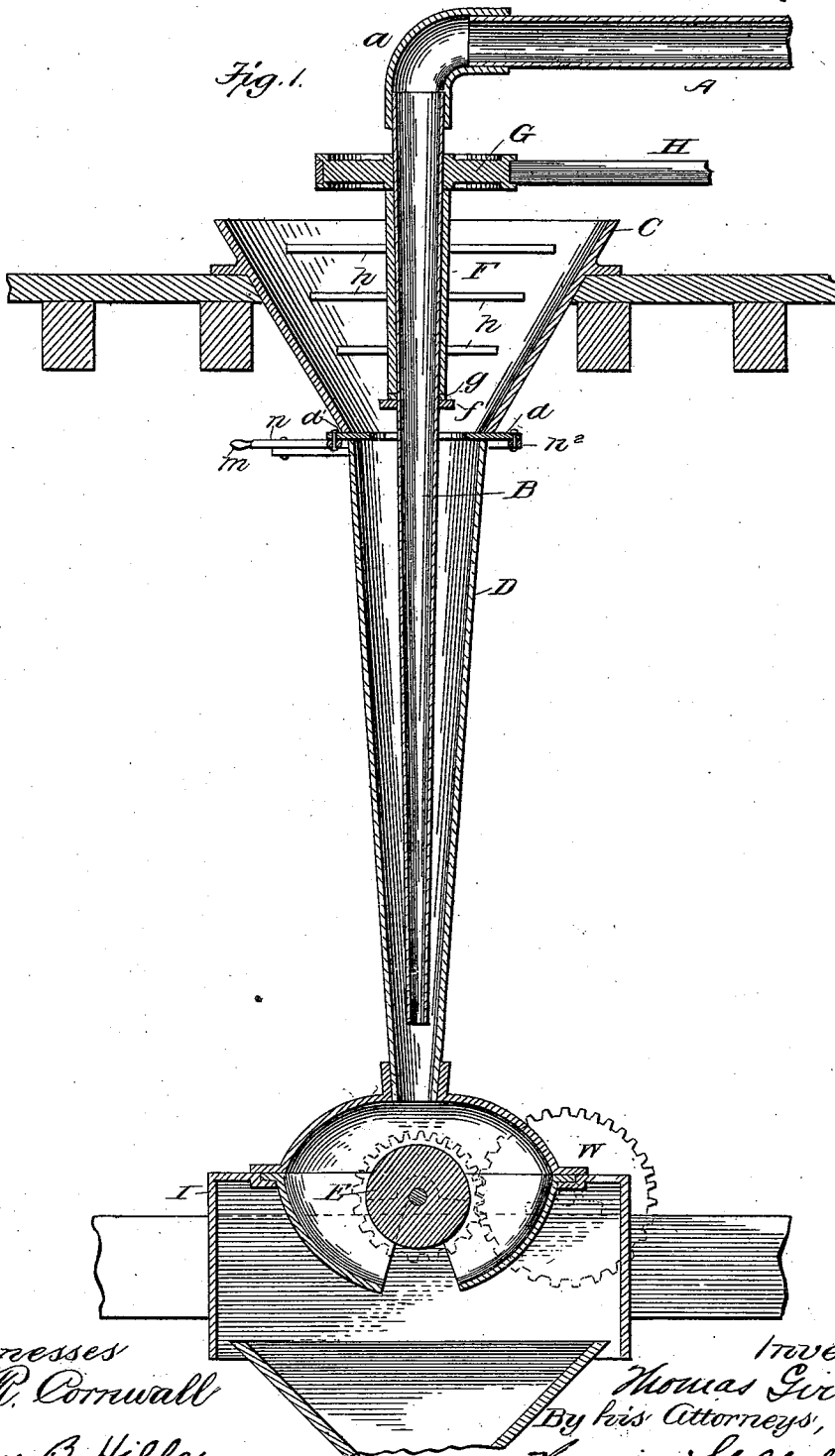

Witnesses  
S. G. Cornwall  
Levy B. Hills.

Inventor,  
Thomas Girvan,  
By his Attorneys,  
Yennie & Goldborough

T. GIRVAN.  
REDUCTION APPARATUS.

No. 522,590.

Patented July 10, 1894.

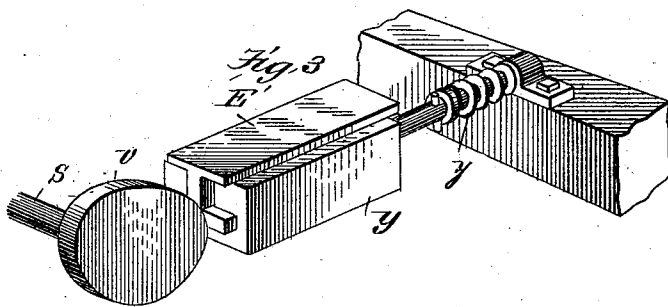
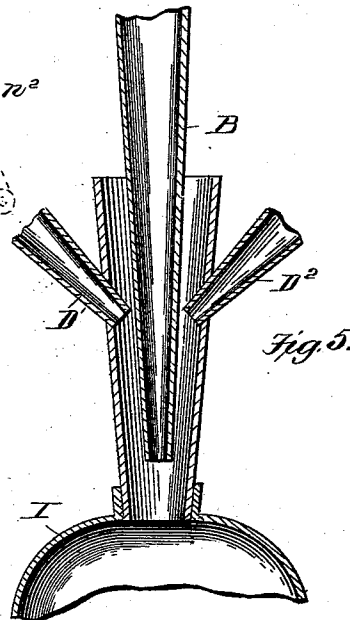
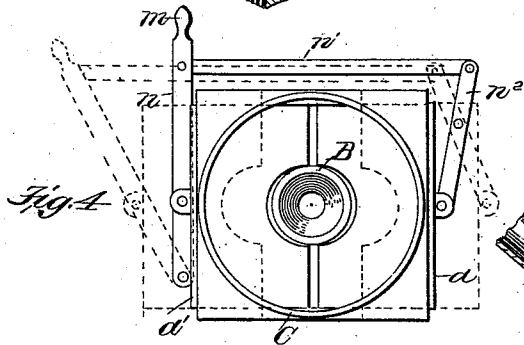
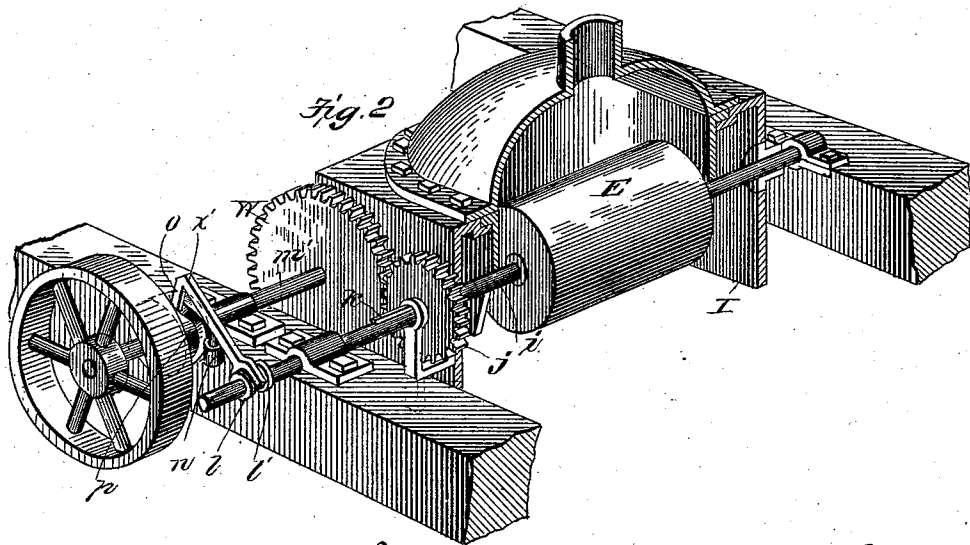

Witnesses  
*T. R. Cornwall*  
*Cecy B. Hills*

Inventor  
*Thomas Girvan,*  
 By his Attorneys,  
*Peune & Goldborough*

# UNITED STATES PATENT OFFICE.

THOMAS GIRVAN, OF NEW YORK, N. Y., ASSIGNOR TO GEORGE T. GIRVAN,  
OF SAME PLACE.

## REDUCTION APPARATUS.

SPECIFICATION forming part of Letters Patent No. 522,590, dated July 10, 1894.

Application filed March 2, 1892. Serial No. 423,452. (No model.)

*To all whom it may concern:*

Be it known that I, THOMAS GIRVAN, a citizen of the United States, residing at New York, in the county of New York and State of New York, have invented certain new and useful Improvements in Reduction Apparatus; and I do hereby declare the following to be a full, clear, and exact description of the invention, such as will enable others skilled in the art to which it appertains to make and use the same.

My invention has reference to apparatus for reducing substances and has relation more particularly to that class of apparatus wherein substances under the impulsion of a jet or moving column of liquid, are hurled against an abutment and fractured by impact therewith.

An illustration of the class of devices referred to is disclosed in United States Letters Patent No. 269,742, issued December 26, 1882, to Francis Taggart, wherein is represented a vertical pipe conveying a descending column of water under high pressure, the material to be reduced being supplied to said pipe near the upper end of the vertical portion thereof and a revolving abutment being in front of the discharge end of the said pipe. While the patented construction referred to is highly satisfactory in use, experience has shown that it is susceptible of improvement in several important particulars.

One of the results which my present invention attains, is the avoidance of the undue expenditure of force and the frictional wear occasioned by carrying the substance along a considerable portion of the vertical pipe before hurling it against the abutment.

By my improvements herein described, the substance is only subjected to the motive force of the jet or column of water at that period when it is to be hurled directly against the abutment; thereby securing the full force and effect of the jet of water and preventing undue wear of parts of the apparatus.

Since only a comparatively narrow width of the peripheral surface of the revolving abutment in said patented construction receives the impact of the material the capacity of said abutment for resisting wear is necessarily restricted. I have herein devised means for largely increasing the available impact

surface of the abutment, thereby greatly enhancing its durability and efficiency.

In the accompanying drawings forming part of this specification, Figure 1, is a vertical sectional elevation of so much of an impact reduction apparatus as is necessary to show the main features of my present invention. Fig. 2 is a perspective view, partly in section, of my improved abutment and the devices for operating the same. Fig. 3 represents a modification of my improved abutment. Fig. 4 is a detail view of the hand devices for operating the valves of the hopper, and Fig. 5 is a vertical sectional view of a modified form of the jet-discharge devices.

The pipe A, conveying water under pressure from the pump has a bend at *a*, from which point the pipe forms a vertical descending jet pipe B, which passes through the hopper C, and if desired, may be contracted at its lower end as shown, to concentrate the force of the water jet. From the bottom of the hopper C, extends a pipe D, of larger dimensions than the pipe B, and surrounding the latter, the space intermediate of said pipes B and D, being of sufficient size to enable the free feed and descent of the material from the hopper.

As will be seen from an inspection of Fig. 1, the pipe D, is continued down to a point below the discharge end of the jet pipe B, so that as the material passes said discharge end the force of the jet may be concentrated upon it so as to hurl it directly against the abutment E below.

I prefer to provide the hopper at its base with a valve or valves *d, d'*, by which the feed of material to the pipe D, may be controlled or cut-off at pleasure. The valves *d, d'*, are represented as consisting of two sliding horizontal plates preferably connected by links *n n'* *n''* having an operating handle *m* so that one movement of the latter will simultaneously move both valves, as clearly exhibited in Fig. 4.

With a view to securing a uniform feed of the material to the pipe D, and preventing it from becoming packed in the hopper, I provide the latter with a stirrer or agitating device one form of which is shown in Fig. 1.

A vertical sleeve F, embraces and revolves

on the pipe B, within the hopper C, said sleeve being supported at its lower end by resting on a collar *f*, secured to said pipe. A washer *g*, of anti-friction metal may be interposed  
 5 between the collar and sleeve to avoid frictional wear. To the upper part of the sleeve F, is secured a band pulley G, which by means of a belt H, conveys power from any convenient source and rotates the pulley and sleeve.  
 10 The latter is provided with a series of arms *h*, for agitating the contents of the hopper. The abutment E, may be arranged in either a closed or open tank I, as circumstances or the character of the material to be reduced  
 15 may require.

Experience has shown that abutments made even of the hardest metals wear very rapidly and therefore have to be frequently replaced. In Fig. 2, the abutment E is represented as  
 20 consisting of a horizontal cylinder, mounted upon a shaft *i*, supported loosely in suitable bearings so as to be capable of longitudinal movement within said bearings. The shaft *i* at one end of the abutment E, is provided  
 25 with a spline *k*, engaging a groove therefor in the cog-wheel *j*, which cog-wheel is geared to the power shaft *m'* by means of the cog-wheel *w*. It will be seen that the spline secures the desired revolution of the shaft *i* and abutment  
 30 E, but permits their longitudinal movement relatively to the wheel *j*. Two collars *l, l*, are rigidly secured on the shaft *i*, between which extends the bifurcated end of a lever *x'*, mounted on a vertical pivot *n*, to vibrate laterally,  
 35 the other end of said lever being provided with a depending pin *o*, entering a cam groove in the periphery of the cam wheel *p* fast upon the power shaft. By means of these devices the shaft will be slowly reciprocated,  
 40 thereby moving the abutment E to and fro during its rotation and largely increasing the extent of surface receiving the impact of the material.

Another construction of laterally shifting  
 45 abutment is represented in Fig. 3, wherein the abutment E' consists of a transverse horizontal plate guided in a horizontal box *y*, one end of which abutment E' bears against a coiled spring *z*, while the other end is in contact  
 50 with a cam *v* on the power shaft S. By this arrangement, the cam shifts the abutment plate in one direction and compresses the spring, and, as the cam ceases to act, the spring moves the plate in an opposite direc-

tion, thus securing an equal wear upon the 55 upper surface of the same.

In some instances, I may, as shown in Fig. 5, so arrange the feed pipes D', D<sup>2</sup>, supplying the material, that said feed pipes shall enter separately a short distance above the end of  
 60 the jet discharge pipes, securing practically the same effect as when the feed is from the hopper C.

It will, of course, be understood that the material after its reduction is to be sorted by  
 65 screens or otherwise into suitable grades, and the tailings returned for further treatment.

Having thus described my invention, what I claim is—

1. In an apparatus for the reduction of sub-  
 70 stances, the combination with a jet pipe for conveying the motive fluid and having its discharge portion tapering as described, of a feed pipe for delivering the material adjacent to the tapering discharge portion said feed  
 75 pipe being continued beyond the jet pipe and tapering at its discharge opening; together with an abutment, substantially as set forth.

2. In an apparatus for the reduction of sub-  
 80 stances, the combination with the jet feed pipe and abutment, of a hopper, and a valve device comprising two slides encircling the jet pipe and an operating lever, for simultaneously operating both slides, substantially  
 85 as set forth.

3. In an impact-pulverizer, the combination with the jet-projecting nozzle, of an abutment arranged in front of the nozzle and against  
 90 which the solid material of the jet is shattered by impact, and means for reciprocating the abutment during the operation; substantially as described.

4. In an impact-pulverizer, the combination with the jet-projecting nozzle, of an abutment consisting of a cylinder whose periphery is ar-  
 95 ranged in front of the nozzle and against which the solid material of the jet is shattered by impact, means for rotating the cylinder, and means for moving the cylinder longitudinally during the operation; substantially as  
 100 described.

In testimony whereof I affix my signature in presence of two witnesses.

THOMAS GIRVAN.

Witnesses:

WM. A. EASTERDAY,  
 JOHN C. PENNIE.