



(22) **Date de dépôt/Filing Date:** 2013/03/28
(41) **Mise à la disp. pub./Open to Public Insp.:** 2013/09/30
(45) **Date de délivrance/Issue Date:** 2020/03/24
(30) **Priorité/Priority:** 2012/03/30 (IT TO2012A 000284)

(51) **Cl.Int./Int.Cl.** *B64F 5/10* (2017.01),
B64C 1/00 (2006.01), *B64C 1/12* (2006.01)
(72) **Inventeurs/Inventors:**
SIBONA, GUIDO, IT;
MOSTARDA, ETTORE, IT;
IOVINE, GIUSEPPE, IT
(73) **Propriétaire/Owner:**
LEONARDO S.P.A., IT
(74) **Agent:** GOWLING WLG (CANADA) LLP

(54) **Titre : SYSTEME D'ACTIONNEMENT DES SECTEURS D'UN DISPOSITIF POUR LA PRODUCTION D'UN FUSELAGE D'AERONEF**

(54) **Title: ACTUATING SYSTEM OF SECTORS OF A DEVICE FOR PRODUCING AN AIRPLANE FUSELAGE**

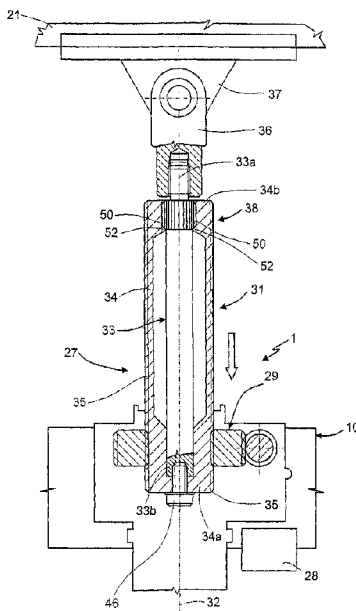

(57) **Abrégé/Abstract:**

An actuating system of sectors of a device for producing an airplane fuselage in which a lamination mandrel is delimited by an external surface which defines a rotation solid with respect to a symmetry axis and comprises a plurality of sectors angularly spaced about the axis and mobile along guides between: an expanded lamination position; and a contracted disassembling position. Each sector is provided with an actuating system of the screw as a threaded element extending along a rotation axis mounted axially on a portion of shaft and provided externally with a thread. Constraint means are provided between the internal shaft and a tubular portion adapted to prevent angular displacement. A thermal stress applied to the threaded element produces the sliding of a free end portion so that an increase in the temperature does not produce an overall elongation of the threaded element.

ABSTRACT

An actuating system of sectors of a device for producing an airplane fuselage in which a lamination mandrel is delimited by
5 an external surface which defines a rotation solid with respect to a symmetry axis and comprises a plurality of sectors angularly spaced about the axis and mobile along guides between: an expanded lamination position; and a contracted disassembling position. Each sector is provided with an
10 actuating system of the screw as a threaded element extending along a rotation axis mounted axially on a portion of shaft and provided externally with a thread. Constraint means are provided between the internal shaft and a tubular portion adapted to prevent angular displacement. A thermal stress
15 applied to the threaded element produces the sliding of a free end portion so that an increase in the temperature does not produce an overall elongation of the threaded element.

"ACTUATING SYSTEM OF SECTORS OF A DEVICE FOR PRODUCING AN AIRPLANE FUSELAGE"

The present invention concerns an actuating system of sectors
5 of a device for producing an airplane fuselage.

The patent application PCT WO 2007/148301 describes a device
for producing an airplane fuselage in which a lamination
mandrel is delimited by an external surface which defines a
10 rotation solid (in particular a cylinder) with respect to a
symmetry axis. The lamination mandrel is adapted to receive
and support a band of impregnated synthetic material which is
wound and deposited on the external surface of the mandrel in
a lamination phase forming a plurality of overlapped layers.
15 Said overlapped layers are subjected to a subsequent high
temperature polymerisation process under vacuum in an
autoclave for forming a structural section of the airplane
(typically a tubular portion of fuselage).

20 The lamination mandrel comprises a plurality of sectors
angularly spaced about the axis and borne by guides which
extend radially from a supporting grid structure. The sectors
are mobile between: an expanded lamination position in which
the sectors have greater rectilinear edges parallel to the
25 axis arranged side by side and the external surfaces of the
sectors opposite the axis define the external surface; and a
contracted disassembling position in which the sectors
approach the axis moving away from the trace of the surface to
allow extraction of the lamination mandrel from the structural
30 section of the airplane at the end of the polymerisation
process under vacuum.

In the expanded lamination position it is essential for the
sectors to maintain an angularly and axially stable position
35 with respect to one another since any slight movements between
the parts can irreparably alter the geometry of the structural

section. For example the patent applicant has pointed out that a lamination mandrel used for producing structural sections of large passenger airplanes must have low dimensional tolerances, below - for example -0.5 mm.

5

The movement of each sector from the expanded lamination position to the contracted disassembling position is normally performed by means of a screw - nut screw actuating system driven by an electric motor positioned on the supporting grid structure.

10

Said screws are normally made of steel which, as is known, is a metal that expands considerably at high temperatures; the patent applicant has in fact observed that at the temperatures normally reached in an autoclave (around 200-300C°) the screws normally used elongate by a few mm (for example approximately ten mm), moving the sectors from the expanded lamination position reached when cold to an expanded position in which the external surface has a greater diameter than that of the external surface, again when cold.

15

20

Said phenomenon results in the structural section of the airplane having dimensions not corresponding to the design dimensions, therefore it cannot be used (for example since it is not able to couple with other sections).

25

The need is therefore felt to produce a sector actuation system that solves the above-mentioned technical problem and is not sensitive to the thermal cycles performed in the autoclave.

30

The documents DE195 25 023, JP2002 361541, US 4 802 558 and US 2010/155984 represent known prior art.

35

The preceding object is achieved by the present invention which relates to an actuating system of sectors of a device

for producing an airplane fuselage in which a lamination mandrel is delimited by an external surface which defines a rotation solid with respect to a symmetry axis; said lamination mandrel is adapted to receive and support a band of
5 impregnated synthetic material which is deposited and wound on the external surface forming a plurality of overlapping layers which are subjected to a high temperature polymerisation process under vacuum for forming a structural section of the airplane; the lamination mandrel comprises a plurality of
10 sectors angularly spaced about the axis and mobile along guides between: - an expanded lamination position in which the sectors have greater rectilinear edges parallel to the axis arranged side by side and the external surfaces of the sectors opposite the axis define together said external surface; and -
15 a contracted disassembling position in which at least part of said sectors approaches the axis moving away from the trace of the surface to reduce the radial dimensions of the mandrel and allow extraction of said mandrel from the structural section of the airplane; each sector being provided with a screw - nut
20 screw type actuating system comprising a threaded rectilinear element extending along a radial rotation axis, a nut screw and motor means, characterised in that said threaded rectilinear element comprises an internal shaft made of a first material and extending along said rotation axis and an
25 external tubular portion made of a second material, axially mounted on a portion of said internal shaft and provided externally with said threading; said first material having a dilatation coefficient smaller than the dilatation coefficient of the second material; constraint means are provided between
30 said internal shaft and said external tubular portion adapted to prevent angular displacement of the external tubular portion with respect to the internal shaft allowing a linear sliding of the external tubular portion with respect to the internal shaft; a first end portion of the external tubular
35 portion being connected to a respective end portion of said internal shaft; a thermal stress applied to said threaded

element producing a sliding of a second free end portion of the external tubular portion with respect to the internal shaft so that said stress does not produce an overall elongation of the threaded rectilinear element and each sector
5 remains in the previously defined expanded lamination position also following said thermal stress.

The invention will now be illustrated with reference to the accompanying figures which show a preferred embodiment example
10 in which:

- figure 1 illustrates - in a perspective view - a device for producing an airplane fuselage which uses an actuating system according to the invention;
- figure 2 illustrates - in a perspective view - the internal
15 structure of the device illustrated in figure 1;
- figure 3 illustrates in a lateral view and on an enlarged scale a cross section of the device illustrated in figures 1 and 2 which highlights the actuating system produced according to the invention;
- 20 - figure 4 illustrates in longitudinal section a portion of the actuating system in a first closed operating position;
- figure 5 illustrates in longitudinal section a portion of the actuating system in a second open operating position.

25 In figures 3, 4 and 5 an actuating system of sectors of a device 2 (figure 1) for producing an airplane fuselage is indicated overall by 1.

In particular the device 2 (figure 1) comprises a lamination
30 mandrel 4 delimited by an external surface 5 which defines a rotation solid with respect to a symmetry axis 7. The lamination mandrel 4 is adapted to receive and support a band of impregnated synthetic material which is deposited and wound on the external surface 5 forming a plurality of overlapping
35 layers which completely and uniformly cover the surface 5. The band of synthetic material (for example carbon fibre) is

deposited by a lamination head (of known type - not illustrated) on the lamination mandrel 4.

For example, the band can be deposited by causing the mandrel
5 4 to rotate about the axis 7 and causing the lamination head
(not illustrated) to translate in a coordinated manner along
said axis 7. For example, the patent application
US2005/0039843 illustrates a lamination head. At the end of
lamination of the band, the band of impregnated composite
10 material is subjected to a polymerisation process under vacuum
to produce a tubular structural section of the airplane. Said
process is carried out by placing the lamination mandrel 4 in
an autoclave (not illustrated) and performing a thermal
heating cycle of known type.

15

In the example shown, the external surface 5 is cylindrical
and the lamination mandrel 4 is used to produce a cylindrical
tubular portion of the airplane fuselage.

20 The lamination mandrel 4 comprises a plurality of sectors 12
(figures 5 and 6 illustrate - by way of example - six sectors
12) angularly spaced about the axis 7 and borne by a
supporting structure 10 (shown schematically in figure 2)
which extends in a linear manner along the axis 7.

25

The sectors 12 are mobile between:

- an expanded lamination position (figures 1 and 5) in which
the sectors 12 have greater rectilinear edges 13 parallel to
the axis 7 arranged side by side and the external surfaces of
30 the sectors 12 opposite the axis 7 are adjacent to one another
and define - as a whole - the cylindrical surface 5; and
- a contracted disassembling position (figure 5) in which the
sectors 12 approach the axis 7 moving away from the trace of
the surface 5, reducing the radial dimensions of the mandrel 4
35 to allow extraction of the mandrel 4 from the structural
section of the airplane at the end of the process.

The supporting structure 10 extends between a first and a second annular end portion 16a, 16b (figure 2), each of which is provided with a respective frustoconical-shaped end portion 17a, 17b which extends axially.

The frustoconical end portions 17a, 17b are made of a metallic material and each delimit a central opening 18 coaxial with the axis 7.

10

The patent application WO 2007/148301 provides an example of embodiment and use of a structure of the above-mentioned type and of the end portions 17a, 17b.

Each sector 12 comprises a curved metallic wall 20 (figures 3, 5 and 6) which in cross section has the profile of an arc of a circle with aperture of 60° and centre in the axis 7 and a stiffening structure 21 formed of a plurality of ribs 21 spaced axially from one another and facing towards the inside of the mandrel 4 to prevent deflections/deformations of the wall 20 ensuring that the surface 5 remains perfectly cylindrical and coaxial with the axis 7.

The adjacent edges 13 of two contiguous sectors 12 are adapted to position themselves one above the other in a perimeter overlap region 13s (figure 4).

Between the stiffening structure 21 of each sector 12 and the supporting structure, a pair of rectilinear guides 17 (of known type and therefore not further illustrated) is provided, adapted to support the sector 12 and allow a linear translation movement, in a radial direction with respect to the axis 7 and in opposite directions, of each curved wall 20 between the expanded and contracted lamination positions.

35

The movement of each sector is achieved by an actuating system

27 (illustrated on an enlarged scale in figure 3) positioned between the pair of guides 15 and provided with an electric motor 28 (figure 3, shown schematically) configured to achieve the above-mentioned translation movement.

5

Again according to the present invention the actuating system 27 is of the screw - nut screw type and comprises a nut screw 29 borne by the supporting structure 10 and rotated by the motor 28 (for the sake of simplicity, the transmission is not illustrated in figure 3) and a rectilinear threaded element 31 coupled with the nut screw 29 and having one end connected to the stiffening structure 21 of a sector 12. The rectilinear threaded element 31 extends in a radial direction along an axis 32 which lies on a plane perpendicular to the axis 7.

15

Alternatively the nut screw 29 could be arranged on the stiffening surface 21 of a sector 12 and the threaded element 31 borne by the supporting structure 10 and rotated by the motor 28.

20

The threaded element 31 comprises an internal shaft 33 (figure 3) made of a first metallic material and extending along the rotation axis 32 and an external cylindrical tubular portion 34 made of a second metallic material, mounted axially on a portion of the shaft 33 and provided externally with a thread 35 which engages with the nut screw 29 which is borne by the supporting structure 10 and rotated by the electric motor 28 (as highlighted above, for the sake of simplicity the transmission positioned between the output shaft of the motor 28 and the nut screw 29 is not shown). The length of the external tubular portion 34 is approximately equal to the length of the internal shaft 33 which is thus covered almost throughout its length and contained within a cylindrical cavity defined by the tubular portion 34.

35

The first metallic material (for example INVAR 36) has a

dilatation coefficient smaller than the dilatation coefficient of the second metallic material (for example steel).

For example the steel can have the following thermal dilatation coefficient (expressed in mm/C°)

Alloy steel	18NiCrMo5	0.0124
Alloy steel	34CrNiMo6	0.0124
Alloy steel	42 CrMo 4	0.0124
Cylinder steel	St35 - St37	0.0124
Cylinder steel	ST 52	0.0124
Cylinder steel	ST E 460	0.0124
Stainless steel	AISI 304 X5CrNi 18-10	0.0165
Stainless steel	AISI 316 X5CrNiMo 17-12-2	0.0165
Stainless steel	AISI 410 X12 Cr 13	0.011
Stainless steel	AISI 420 X30 Cr 13	0.011
Stainless steel	AISI 430 X6 Cr 17	0.01
Stainless steel	AISI 630 X5CrNiCuNb 16-4	0.011
Stainless steel	AISI 904 X1NiCrMoCu25-20-5	0.0161
Hardened stainless steel	X105 Cr Mo 17	

As is known, Invar is a metal alloy consisting mainly of iron (64%) and nickel (36%), with traces of carbon and chromium, discovered by the Swiss Nobel prize-winner physicist Charles Edouard Guillaume. Its thermal dilatation coefficient (approximately 10^{-6} K⁻¹ in length) is approximately one tenth

compared to that of steel.

The second metallic material has a dilatation coefficient greater than the dilatation coefficient of the first material
5 but has better mechanical strength characteristics than those of the first material.

The shaft 33 has a first end portion 33a from which a rectangular plate 36 extends which in turn is hinged to a
10 bracket 37 which extends radially from the stiffening structure 21 towards the axis 7.

The first end portion 33a is not covered by the cylindrical tubular portion 34 and has a smaller diameter than the portion
15 of the shaft 33 covered by the cylindrical portion 34.

A second end portion 33b of the shaft 33 is provided with an axial hole housing a terminal portion of a screw 46 used to
20 fix in a stable manner a first end portion 34a of the tubular portion 34 to the shaft 33.

Between the internal shaft 33 and the tubular portion, angular constraint means 38 are provided, adapted to prevent angular
25 displacement of the tubular portion 34 with respect to the internal shaft 33 (and therefore allow transfer of the torque generated by the electric motor 28 to the shaft 33) but allowing linear sliding of the tubular portion 34 with respect to the internal shaft 33 following thermal stress applied to the threaded element 31 as a whole.

30 For example, the constraint means 38 can be made of a plurality of longitudinal ribs 50 (for example with triangular section - figure 3) provided on the external surface of a terminal portion of the internal shaft 33 and adapted to
35 couple with relative longitudinal grooves 52 provided on the internal surface of a terminal portion of the tubular portion

34.

In this way a temperature increase applied to the threaded element 1 (the temperature increase is caused by a thermal cycle performed in an autoclave) produces a deformation of the tubular portion 34 which elongates, moving the second end portion 34b of the tubular portion towards the plate 35 (the constraint means 38 allow relative sliding between the parts and the second end portion 34b is free to move) with respect to the internal shaft 33 which is not subject to significant dimensional variations due to the material used. The overall length of the threaded element 31 in any case increases very little since it is defined by the distance between the end portions 33b and 33a of the internal shaft 33 which has an extremely limited dilatation coefficient. In this way, the thermal stress produces a limited overall elongation of the threaded rectilinear element 31 which depends only on the reduced elongation of the first material.

Therefore, the autoclave heating of the device 2 does not entail a shifting of the sectors 12 with respect to the position defined prior to the heating. The required dimensional tolerances of the tubular fuselage element of the airplane are thus guaranteed.

Furthermore the nut screw couples with threads made of wear-resistant metallic material, thus providing a robust actuating system able to withstand a plurality of sector opening/closing cycles.

30

THE EMBODIMENTS OF THE INVENTION IN WHICH AN EXCLUSIVE PROPERTY OR PRIVILEGE IS CLAIMED ARE DEFINED AS FOLLOW:

1. An actuating system of sectors of a device for producing an airplane fuselage in which a lamination mandrel is defined by an external surface which defines a rotation solid with respect to a symmetry axis; said lamination mandrel is adapted to receive and support a band of impregnated synthetic material which is deposited and wound on the external surface forming a plurality of overlapping layers which are subjected to a high temperature polymerisation process under vacuum for forming a structural section of the airplane;
- the lamination mandrel comprises a plurality of sectors angularly spaced about the axis and mobile along guides between:
- an expanded lamination position in which the sectors have rectilinear edges parallel to the axis and arranged side by side and external surfaces of the sectors opposite to the axis define together said external surface; and
 - a contracted disassembling position in which at least part of said sectors approaches the axis moving away from the trace of the surface to reduce the radial dimensions of the mandrel and allow the extraction of the mandrel itself from the structural section of the airplane;
- each sector being provided with an actuating system of the screw - nut screw type comprising a threaded rectilinear element extending along a radial rotation axis, a nut screw and motor means,
- characterised in that said threaded rectilinear element comprises an internal shaft made of a first material and extending along said rotation axis and an external tubular portion made of a second material, axially mounted on a portion of said internal shaft and externally provided with said threading;

said first material having a dilatation coefficient smaller with respect to the dilatation coefficient of the second material;

5 constraint means are provided between said internal shaft and said external tubular portion, adapted to prevent the angular displacement of the external tubular portion with respect to the internal shaft allowing a linear sliding of the external tubular portion with respect to the internal shaft;

10 a first end portion of the external tubular portion being connected to a respective end portion of said internal shaft;

a thermal stress applied to said threaded element producing a sliding of a second free end portion of the external tubular portion with respect to the internal shaft so that said stress produces a limited overall elongation of the threaded
15 rectilinear element which depends only on the reduced elongation of the first material and each sector remains in the previously defined expanded lamination position also following said thermal stress.

20 2. The system according to claim 1, wherein said constraint means comprise a plurality of longitudinal ribs obtained on a respective external surface of a portion of said internal shaft adapted to couple with relative longitudinal grooves obtained on the internal surface of a respective portion of said
25 external tubular portion.

3. The system according to claim 1, wherein said first material is INVAR 36 and the second material is steel.

30 4. The device according to claim 1, wherein said nut screw and said motor means are borne by an internal support structure of said mandrel and said threaded rectilinear element has an end portion coupled with a respective sector.

5. The system according to claim 1, wherein each sector comprises a curved wall which has a cross section with the profile of an arc of a circle and a stiffening structure facing inwardly of the mandrel and adapted to prevent
5 deflections/deformations of the wall.

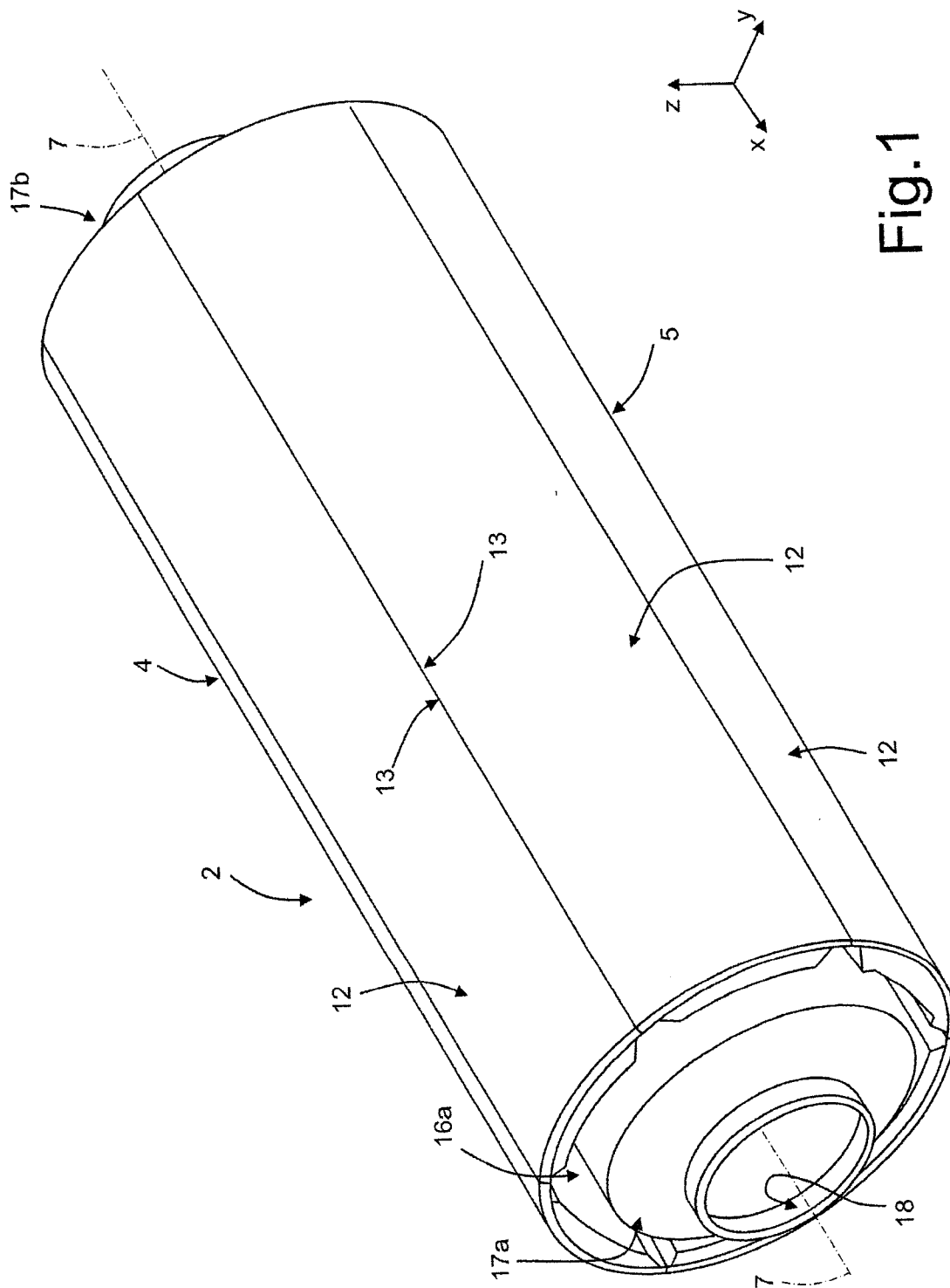

Fig.1

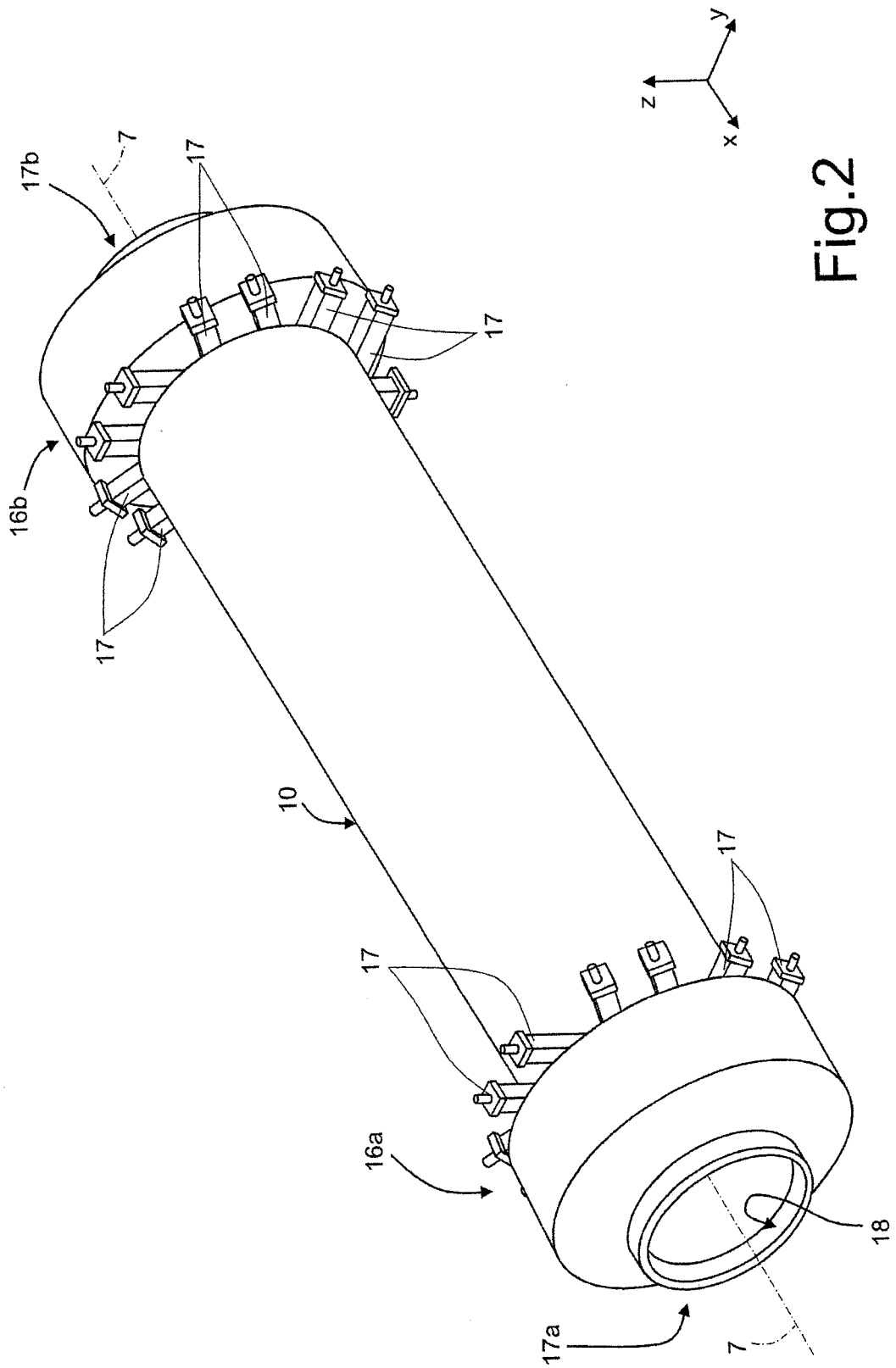

Fig.2

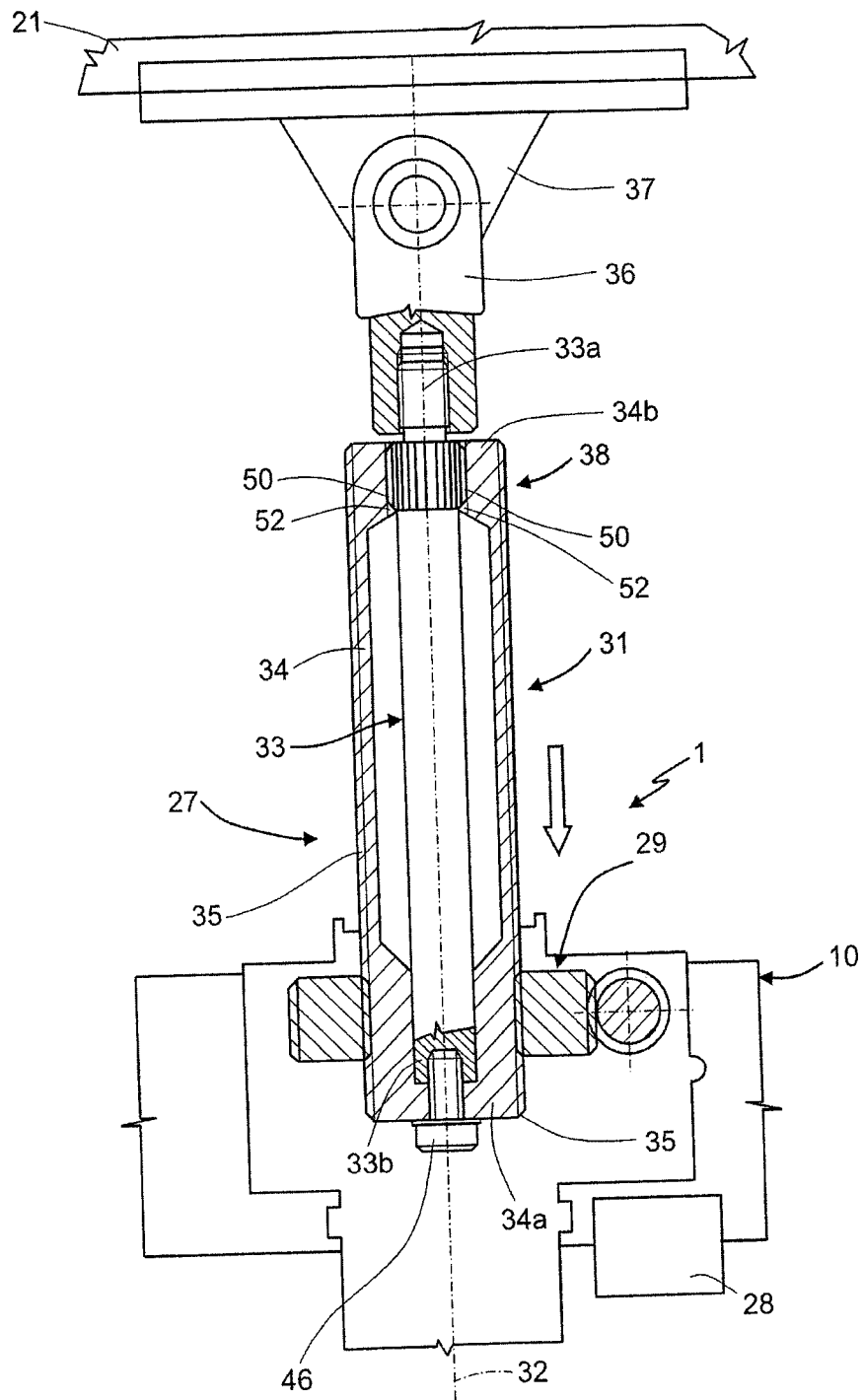

Fig.3

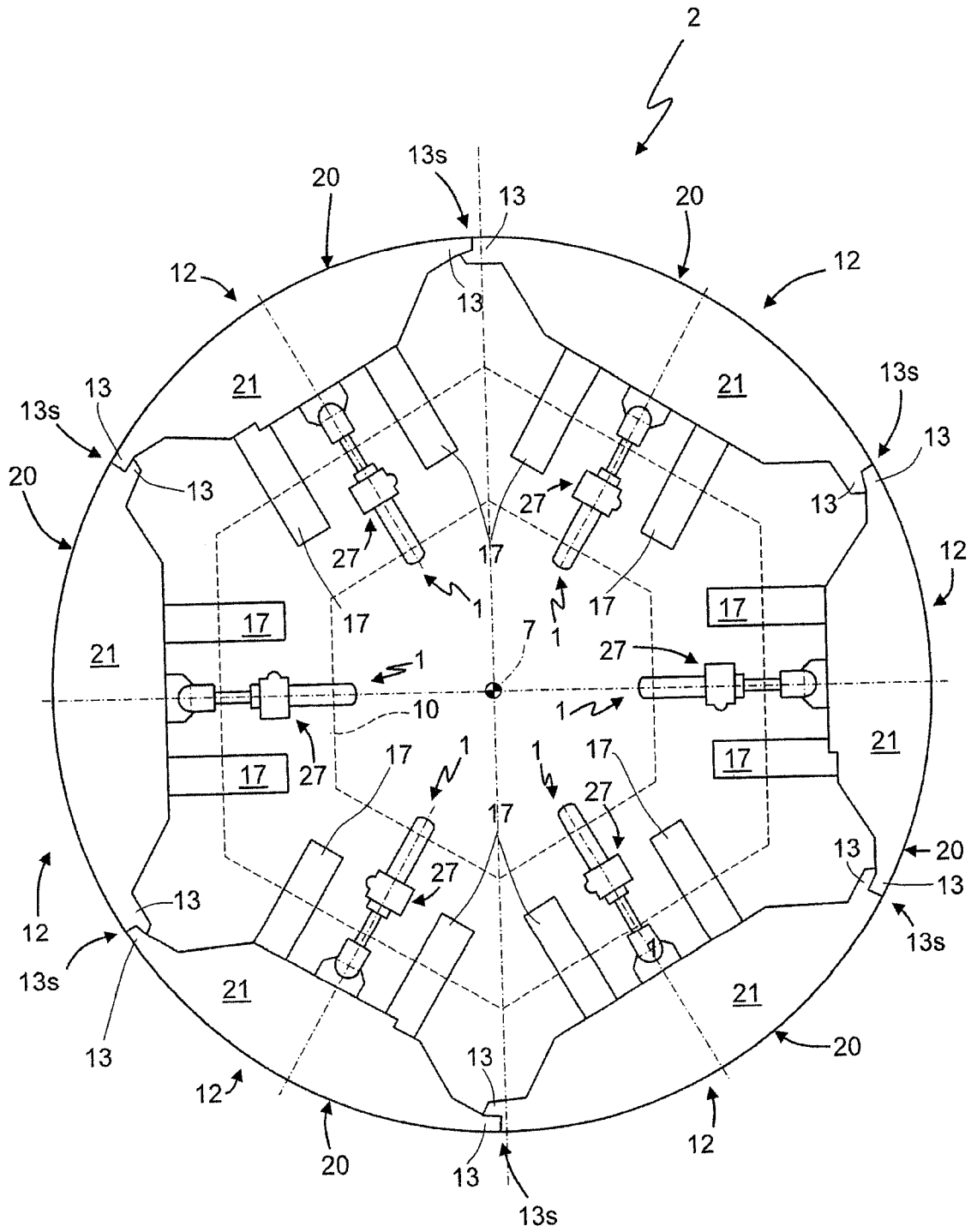

Fig. 4

