

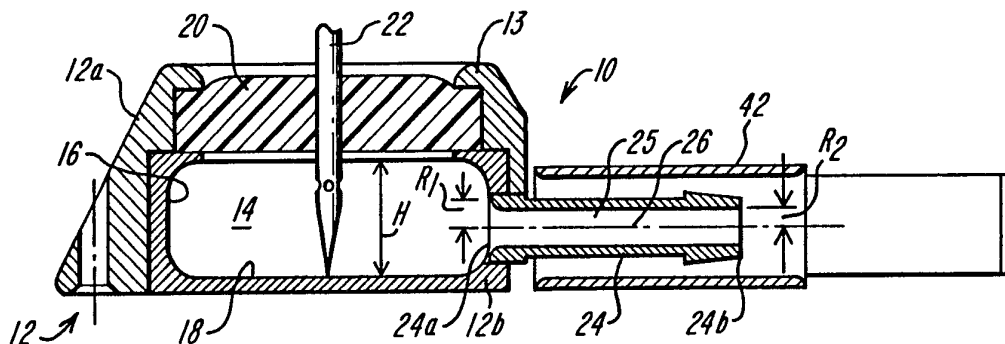

INTERNATIONAL APPLICATION PUBLISHED UNDER THE PATENT COOPERATION TREATY (PCT)

<p>(51) International Patent Classification ⁵ : A61M 5/32</p>	<p>A1</p>	<p>(11) International Publication Number: WO 90/14118 (43) International Publication Date: 29 November 1990 (29.11.90)</p>
<p>(21) International Application Number: PCT/US90/02681 (22) International Filing Date: 11 May 1990 (11.05.90) (30) Priority data: 354,614 19 May 1989 (19.05.89) US (71) Applicant: STRATO MEDICAL CORPORATION [US/US]; 123 Brimbal Avenue, Beverly, MA 01915 (US). (72) Inventors: LOITERMAN, David, A. ; 1806 Midwest Club, Oak Brook, IL 60521 (US). FENTON, Paul, V., Jr. ; 12 Cedar Street, Marblehead, MA 01945 (US). YOUNG, Thomas, M. ; 35 Bixby Avenue, North Andover, MA 01845 (US). (74) Agents: LAPPIN, Mark, G. et al.; Lahive & Cockfield, 60 State Street, Boston, MA 02109 (US).</p>		<p>(81) Designated States: AT (European patent), AU, BE (European patent), CA, CH (European patent), DE (European patent)*, DK (European patent), ES (European patent), FR (European patent), GB (European patent), IT (European patent), JP, LU (European patent), NL (European patent), SE (European patent). Published <i>With international search report.</i></p>
<p>(54) Title: VASCULAR ACCESS SYSTEM FOR EXTRACORPOREAL TREATMENT OF BLOOD</p>		



(57) Abstract

Disclosed is an implantable vascular access port (10) including a biocompatible housing (12) having at least one internal open-faced chamber (14) defined by a concave sidewall (16) and a bottom wall (18); a septum (20) affixed to the housing (12) and spanning the periphery of the open face of said chamber (14), the septum (20) including a biocompatible, self-resealing, penetrable material; and a cannula (24) attached at a first end (24a) thereof to the housing (12) and extending laterally therefrom, and having a second end thereof adapted to receive a catheter (40). The cannula (24) further includes internal walls defining a channel (25) extending from the first end (24a), along a channel axis (26) from a point on the lateral boundary of said chamber, to the second end (24b), the channel having a radius R1 at the first end (24a) and a radius R2 at the second end (24b) where R1 is greater than R2.

DESIGNATIONS OF "DE"

Until further notice, any designation of "DE" in any international application whose international filing date is prior to October 3, 1990, shall have effect in the territory of the Federal Republic of Germany with the exception of the territory of the former German Democratic Republic.

FOR THE PURPOSES OF INFORMATION ONLY

Codes used to identify States party to the PCT on the front pages of pamphlets publishing international applications under the PCT.

AT	Austria	ES	Spain	MC	Monaco
AU	Australia	FI	Finland	MG	Madagascar
BB	Barbados	FR	France	ML	Mali
BE	Belgium	GA	Gabon	MR	Mauritania
BF	Burkina Fasso	GB	United Kingdom	MW	Malawi
BG	Bulgaria	GR	Greece	NL	Netherlands
BJ	Benin	HU	Hungary	NO	Norway
BR	Brazil	IT	Italy	RO	Romania
CA	Canada	JP	Japan	SD	Sudan
CF	Central African Republic	KP	Democratic People's Republic of Korea	SE	Sweden
CG	Congo	KR	Republic of Korea	SN	Senegal
CH	Switzerland	LI	Liechtenstein	SU	Soviet Union
CM	Cameroon	LK	Sri Lanka	TD	Chad
DE	Germany, Federal Republic of	LU	Luxembourg	TG	Togo
DK	Denmark			US	United States of America

-1-

5 VASCULAR ACCESS SYSTEM FOR
 EXTRACORPOREAL TREATMENT OF BLOOD

 BACKGROUND OF THE DISCLOSURE

10 This invention relates to the treatment of
blood, and more particularly to systems and
implantable devices providing direct access to the
vascular system of a patient receiving extracorporeal
blood treatment.

15 The extracorporeal treatment of blood
requires that the vascular system of a subject be
directly accessed, and often accessed repeatedly.
Such treatments include the removal of various
20 components or toxins, and the addition of oxygen to
the blood.

 For example, hemapheresis is a treatment
which involves the collection of blood cells, the
25 removal of a specific blood cell type from the blood,
or plasma exchange. It requires that the vascular
system be tapped with, for example, a needle attached
to a catheter. The blood is then circulated through
an extracorporeal separating device, and then
30 returned to the vascular system via a second needle
stick. Hemapheresis may be performed once or
repeatedly providing that adequate time is allowed
for replacement of the blood cell by the donor's bone
marrow.

35 Another blood treatment is hemodialysis, or
the removal of various chemical substances from the
blood. Such substances include ingested or injected

-2-

drugs, or toxins created during normal body metabolism, the presence of which is most often due to renal impairment. Typically this treatment involves accessing the vascular system, connecting
5 the vasculature to a hemodialysis pump and filtration mechanism, and returning the cleansed blood to the vascular system.

Accessing the vascular system may be
10 achieved by temporary or permanent means, depending on the requirements of the patient. For example, methods are available to establish temporary access involving the percutaneous insertion of a single or double lumen cannula into a large vein such as the
15 subclavian, femoral, or internal jugular.

However, to provide more adequately for the chronic renal impaired patient, it is preferable to surgically rearrange the peripheral vasculature,
20 thereby creating a permanent access. The procedure usually involves connecting a large surface peripheral vein to an artery producing a fistula, or surgically creating a loop between an artery and a vein using a synthetic material such as expanded
25 PTFE. The natural fistula, normally constructed from a vein or venous graft, is preferred over the synthetic loop which is prone to complications such as infections, clotting, and leakage. In either case, the surgery involved in its creation is a
30 lengthy process, and maintaining the resulting reconstruction of the vasculature is a chronic problem. The fistula must mature or become arterialized before it can be accessed with the needles. Then, when it becomes functional, a number

-3-

of complications may arise including clotting, thrombosis, infection, and infiltration of scar-forming cells. In addition, because hemodialysis is a chronic treatment, the required and
5 repeated needle punctures eventually weaken and destroy the arterialized vein, which, to begin with, is abnormally pressurized and particularly susceptible to collapse.

10 Cleansing of the blood alternatively may be conducted by peritoneal dialysis, a treatment which does not necessitate accessing the vascular system. Peritoneal dialysis involves placing a dialysate solution into the peritoneal cavity of a patient via
15 a catheter. The catheter is surgically implanted such that one end is secured within the cavity and the other end is accessible by either projecting through the skin or can be accessed subcutaneously (see for example, U.S. 4,490,137). The dialysate is
20 allowed to remain in the cavity for a predetermined time to allow blood metabolites or toxins (solutes) to cross the highly vascularized peritoneal membrane and enter into the dialysate. The toxin-laden dialysate is later removed through the same
25 catheter.

 However, peritoneal dialysis may not be as desirable as hemodialysis because it rids the blood of metabolites indirectly using the peritoneal
30 membrane as a filter and in fact, only 15% of patients currently receiving blood dialysis therapy undergo peritoneal dialysis.

-4-

Implantable and extracorporeal devices are known for the infusion of medicines and drugs into the vasculature (see, e.g., U.S. Patent nos. 4,673,394, 4,704,103, 4,692,146, and 4,014,328).

5 However, such devices are not useful for extracorporeal blood treatments, as their construction does not take into account the fragile nature of blood elements which are highly susceptible to breakage, or hemolysis during transfer, intrinsic
10 clotting, and immune response.

The implantable vascular access port disclosed in U.S. Patent No. 4,673,394 includes a housing portion having a substantially right circular
15 cylinder shaped, open-faced internal chamber, and a septum spanning the open face of the chamber to establish a closed reservoir. A cylindrical, tubular cannula extends from the sidewall of the chamber for coupling the reservoir to an external catheter. With
20 such a configuration, the chamber and cannula geometries are ill-suited for the transfer of blood elements through the access port, particularly at the flow rates and pressures that are required for current hemodialysis techniques. As blood is
25 transferred through the septum and injected into the chamber, flow patterns are established which include "dead flow" pockets, particularly in the corners of the chamber. Blood cells which enter these pockets merely circulate therein or hardly move at all, and
30 never, or only after a long time, enter the flow through the cannula. Such movement or lack thereof increases the chances of coagulation of the blood. Further, at the relatively high flow rates,

cell-lysing collisions occur at the abrupt interface of the chamber and the cannula. Such collisions are both from cell-to-cell interactions within regions of turbulence and from the physical impact of cells
5 within the chamber sidewalls.

Therefore, it is an object of the present invention to provide an improved method of accessing the vascular system which is antiseptic, less
10 traumatic to the patient, and which has potential for self-access or home care.

It is another object of the invention to provide an easier, quicker method of providing a
15 vascular access which will not require maseuration before it can be used for various extracorporeal blood treatments.

It is also an object to provide an improved
20 vascular access device which can be reliably and repeatedly connected to an extracorporeal blood treatment, and which is durable and easy to use.

SUMMARY OF THE INVENTION

Briefly, the present invention is directed
5 to an implantable vascular access port for use in the
extracorporeal treatment of blood or fractions
thereof. The port includes a biocompatible housing
having an internal open-faced chamber defined by a
concave sidewall and a bottom wall. A septum
10 composed of a biocompatible, self-resealing,
penetrable material is affixed to the housing and
spans the periphery of the open face of the chamber.
To the housing is attached the first end of a
cannula. The cannula extends laterally from the
15 housing, and has a second end adapted to receive a
catheter. In addition, the cannula has internal
walls defining a channel extending from its first
end, along a channel axis from a point on the lateral
boundary of the chamber, to its second end. This
20 channel has a radius R_1 at the first end of the
cannula, and has a radius R_2 at the second end of the
cannula, R_1 being greater than R_2 . Preferably, the
decrease in radius of the channel frame R_1 to R_2 is
monotonic, and provides a smooth and continuously
25 bounded flow path.

The housing of the access port may have lock
means formed adjacent to the port for releasably
engaging a flange of a mating twist-lockable
30 connection. The lock means includes a region of the
bounding surface of the housing defining a void
region adjacent to the port exterior to the chamber.
The lock means also includes means for releasably

-7-

engaging the flange by a partial revolution of such connection, whereby the chamber may be placed in fluid communication with a catheter having such a mating twist-lockable connection.

5

In addition, the lock means may include a means for guiding the catheter connector for rotational motion about an axis passing through the port, and further, a means for capturing the
10 connector so as to prevent its movement along that axis when rotated.

In various embodiments of the invention, the housing of the port includes first and second body
15 members. The first member includes a sidewall and a bottom wall having a cylindrical outer side surface. The second body member is annular (including a cylindrical inner side surface), and includes means for supporting the septum. The outer surface of the
20 first member is adapted to interfit with the inner side surface of the second member. The housing may further include two or more internal open face chambers, each of which having an affixed septum and an attached cannula.

25

In another form of the invention, an implantable vascular access system is provided whereby the vascular access port is coupled to a catheter having a central passage with radius R_2 and
30 an entry port defining a flow path to the central passage along a central axis. The coupling means detachably couples the cannula and the entry port, while selectively establishing a continuous flow path

between the chamber and the central passageway, the channel axis and the central axis being coaxial.

The vascular access system may employ a catheter with a wirewound reinforcing sidewall, and with an end opposite the entry port that is beveled and/or has at least one lateral aperture adjacent thereto. The system may further include a non-coring needle adapted to selectively penetrate the septum.

BRIEF DESCRIPTION OF THE DRAWINGS

The foregoing and other objects of this invention, the various features thereof, as well as 5 the invention, itself, may be more fully understood from the following description, when read together with the accompanying drawings in which:

FIG. 1 shows a cutaway view of an 10 implantable access port according to the invention;

FIG. 2 shows a top plan view of the access port of FIG. 1;

15 FIG. 3 shows a sectional view along lines 3-3 of the access port of FIG. 2;

FIG. 4 shows a side elevation view of the access port of FIG. 2 as viewed from the axis of the 20 cannula;

FIG. 5 shows a side elevation of a needle for use with the access port of FIGs. 1-4;

25 FIG. 6 shows a side elevation view of the tip of the needle of FIG. 5;

FIG. 7 shows an end view of the tip of the needle of FIG. 5 as viewed from the needle axis; 30

FIG. 8 shows in section a catheter for use with the access port of FIGs. 1-4;

-10-

FIGS. 9A and 9B show a coupler for use with the catheter of FIG. 8;

FIG. 10 shows a bottom view of a vascular access port for use with the coupler of FIGS. 9A and 9B;

FIG. 11 shows a top plan view of a portion of the access port of FIG. 10 together with a catheter and coupler;

FIG. 12 illustrates the use of one embodiment of the present invention as an access system for extracorporeal blood treatment; and

FIG. 13 illustrates the use of an alternative embodiment of the present invention as an access system for extra corporeal blood treatment.

DESCRIPTION OF THE PREFERRED EMBODIMENT

Extracorporeal blood treatments such as hemodialysis, plasmapheresis, and hemofiltration
5 require high flow rates to assure adequate clearances, but at pressures low enough to avoid hemolysis and obligatory ultrafiltration. Optimization of blood flow and pressure resistance through the access port is therefore a critical
10 factor in constructing a functional vascular access system. Other considerations include the preservation of blood vessels and blood constituents, and the minimization of access trauma and patient discomfort.

15

The vascular access system of the present invention has been designed with the above-mentioned criteria in mind. This system enables blood to be removed from, and returned back to the vascular
20 system of the body with minimum trauma to accessed blood vessels and blood elements. It can be heparinized to reduce the chance of coagulation therein, and closed off when not in use. In addition, the port reservoir, the catheter, the
25 coupling, and the transitions therethrough have been designed to reduce areas of reduced movement or dead space, thereby minimizing the chance that coagulation may occur.

30 FIG. 1 shows a cutaway pictorial view of an implantable access port 10 according to the present invention. FIGS. 2, 3 and 4 show top plan, sectional and end elevation views, respectively, of the access

-12-

port 10 of FIG. 1. Access port 10 includes a two component housing 12 defining a generally cup-shaped internal open-faced chamber 14 defined by sidewalls 16 and bottom wall 18. The open face of chamber 14 is closed off by a cover member (or septum) 20 which spans the periphery, or lip, of the chamber 14.

Septum 20 is formed of a biocompatible, self-resealing penetrable material, which is preferably an elastomer, such as silicone rubber or latex. Septum 20 is adapted to permit access using a hypodermic needle 22 to the chamber 14.

In the illustrated embodiment, the housing 12 includes an outer body member 12a and an inner body member 12b. In the preferred embodiment, both body members 12a and 12b are formed of a biocompatible material, such as titanium, although surgical grade steel or other biocompatible hard materials can be used. The inner body member 12b includes a generally cylindrical outer lateral surface. The outer body member 12a is generally annular and has a cylindrical inner side surface with a radius substantially matching the outer lateral surface of inner body member 12b, so that the two body members interfit and may be press-fit together to form housing 12. A lip 13 captures the peripheral portion of septum 20. The outer body member 12a has apertures therein, evenly spaced about its perimeter, for suturing the access port to patient tissue when implanting.

-13-

The inner body member 12b includes the internal sidewall 16 and the bottom wall 18 which define chamber 14. The internal sidewall 16 is concave and the bottom wall is generally planar, 5 although there may be some minor variation. An upper lip 15 of inner body member 12b supports the peripheral portion of septum 20.

A cannula 24 is attached at its proximal end 10 to housing 12. Cannula 24 extends laterally from housing 12. The distal end 24b of cannula 24 is adapted for receiving a catheter. The cannula 24 includes internal walls that define a fluid flow channel 25 extending from a point in chamber 14, 15 through the sidewall 16 and along a channel axis 26 to the distal end 24b of cannula 24.

The channel has a radius R_1 at the proximal end 24a and a radius R_2 at the distal end, where R_1 20 is greater than R_2 . In the preferred embodiment, R_1 is 3.4 mm and R_2 is 2.4 mm. The decrease in radius of the channel 25 from R_1 to R_2 is monotonic and is localized near the proximal end 24a, although a more gradual change may also be used. Preferably, the 25 rate of change of radius of channel 25 and the curvature of the sidewall 16 defining chamber 14 is optimally determined to establish an efficient blood flow path between chamber 14 and the distal end 24b of cannula 24.

30

The needle shown in FIG. 1 is substantially the same as a Huber type non-coring needle. For

-14-

blood flow applications, the needle is 16 gauge, having an inner bore diameter of 1.19 mm. This relatively large diameter is adapted to permit relatively high flow rates of blood, for example, 5 300 cc/min.

An alternative form of needle 22 is shown in FIG. 3. This needle, shown in detail in FIGs. 5-7, includes a solid trocar (three plane) point and a 10 pair of opposed lateral ports near the point region 22a. In other embodiments, a single lateral port may be used. The needle 22 is a 16 gauge needle, having an inner bore diameter 1.19 mm, also to accommodate desired blood flow rates. In the preferred 15 embodiment, where the height H of chamber 14 is 8 mm and the maximum diameter is 22 mm, the ports of needle 22 have a 1 mm diameter and are 6 mm from the tip.

20 With the configuration of FIGs. 2-4 and the needle of FIGs. 5-7, the flow pattern for human blood injected into chamber 14 is characterized by substantially improved flow characteristics within chamber 14 which are aimed at reduced flow separation 25 (i.e., eliminating dead flow spaces which could cause clotting), even at flow rates as high as 300 cc/min.

In FIG. 2, an implantable catheter 40 is shown with one end 40' coupled to the cannula 24 30 within a cylindrical metallic coupler 42 having a laterally extending securing tab 44 with a hole 44a. That catheter 40 is shown in section in FIG. 8.

-15-

Catheter 40 includes an elongated, flexible tubular section 46 extending along a catheter axis 40a. Catheter 40 is straight cut at the end 40' intended for coupling to access port 10 and is bevel cut at the other end 40". A plurality of ports 50 are positioned in the sidewalls of catheter 40 near end 40". In the illustrated embodiment, catheter 40 is particularly adapted for receiving human blood and transferring that blood by way of port 10 for extra-corporeal processing, for example, hemodialysis, as described in conjunction with FIG. 12 below. Since that procedure requires pumping of blood from the patient's body, the catheter section 46 includes a helically wound reinforcement wire 48 within its sidewalls to provide sufficient stiffness to prevent collapse during pumping and binding.

A resilient bushing 52, for example, made of silicone, is positioned over and extends from the coupling end 40' of catheter section 46. The bushing 52 is adapted to position the distal end of cannula 24 (having radius R2) and the coupling end of catheter section 46 (also having radius R2) in a butt joint alignment, so that the inner walls of cannula 24 (defining channel 25) and the inner walls of catheter section 46 at end 40' establish a smooth and substantially continuous flow path defining surface.

In order to secure the catheter 40 to the access port 10, coupler 42 is positioned over the bushing 52, compressing that bushing against the outer surface of cannula 24. Then that coupler 42 is positioned so that the hole 44a securing tab 44

overlies one of the peripheral holes in housing 12. In use, the tab 42 may be sutured to the housing 12 through the overlying holes.

5 In alternate embodiments, the coupler 42 may have a T-shaped cross-section, as shown in FIGs. 9A and 9B (with or without tab 44) and the housing 12 may be a T-shaped void region 62 surrounding the cannula 24, as shown in FIG. 10. With this
10 configuration, the coupler 42 may be used to effect a twist lockable attachment of catheter 40 to access port 10, as illustrated in FIG. 11. The separable port and catheter assembly, enables the surgeon to be flexible as to where and how the port is implanted.

15

In another embodiment of the invention, the access port has two or more reservoirs in a unitary housing, each having their own individual catheters or catheter lumens attached thereto (FIG. 13).

20

The access system, including the access port, catheter, and coupling means, may be surgically implanted within the body (e.g., in the vasculature of the chest), such that the port is just beneath the
25 epidermis and above the musculature, and the catheter has accessed the vasculature through a major vessel such as the subclavian vein. As shown in FIG. 12, the system preferably includes both an input port 60 and a removal port 62, with catheters 64 and 66
30 attached thereto and implanted in separate locations in the vasculature (preferably the heart). The ports may accessed transdermally with a needle as described above. Upon termination of extracorporeal treatment,

-17-

the needle accessing the removal port 62 may be removed, followed by the removal of the input port 60-accessing needle.

5 The invention may be embodied in other specific forms without departing from the spirit or essential characteristics thereof. The present embodiments are therefore to be considered in all respects as illustrative and not restrictive, the
10 scope of the invention being indicated by the appended claims rather than by the foregoing description, and all the changes which come within the meaning and range of equivalency of the claims are therefore intended to be embraced therein.

15

We claim:

-18-

CLAIMS

1. An implantable vascular access device including a port comprising:
- 5
- (a) a biocompatible housing having an internal open-faced chamber defined by a concave sidewall and a bottom wall;
- 10
- (b) a septum affixed to said housing and spanning the periphery of the open face of said chamber,
- said septum including a biocompatible, self-resealing, penetrable material; and
- 15
- (c) a cannula attached at a first end thereof to said housing and extending laterally therefrom, and having a second end thereof adapted to receive a catheter,
- 20
- said cannula further having internal walls defining a channel extending from said first end, along a channel axis from a point on said lateral boundary of said chamber, to said second end,
- 25
- said channel having a radius R_1 at said first end and having a radius R_2 at said second end, where R_1 is greater than R_2 .
2. An access port according to claim 1, wherein
- 30 said housing having lock means formed adjacent to said port for releasably engaging a flange of a mating twist-lockable connection,
- said lock means including a region of the bounding surface of said housing,

-19-

said region defining a void region adjacent to said port exterior to said chamber, and including means for releasably engaging said flange by a partial revolution of such connection,

5 whereby the chamber may be placed in fluid communication with a catheter having such a mating twist-lockable connection.

3. An access port according to claim 2, wherein
10 said lock means includes a means for guiding said catheter connector for rotational motion about an axis passing through said port, and means for capturing said connector so as to prevent motion of said connector along said axis when rotated.

15

4. An access port according to claim 1, wherein said housing includes a first body member and a second body member,

 said first body member including said
20 sidewall and said bottom wall having a cylindrical outer side surface, and

 said second body member including means for supporting said septum and being annular and having a cylindrical inner side surface,

25 wherein said outer side surface of said first body member is adapted to interfit with said inner side surface of said second body member.

5. An access port according to claim 1, wherein
30 said housing comprises two or more internal open face chambers as defined in claim 1, each of said chambers having an affixed septum and an attached cannula as defined in claim 1.

6. An implantable vascular access system comprising:

5 (a) a vascular access port including
a biocompatible housing having an
internal open-faced chamber defined by
a concave sidewall and a bottom wall,
10 a septum affixed to said housing
and spanning the periphery of the open
face of said chamber, said septum
including a biocompatible,
self-resealing, penetrable material,
15 a cannula attached at a first end
thereof to said housing and extending
laterally therefrom, and having a
second end thereof adapted to receive a
catheter, said cannula further having
20 internal walls defining a channel
extending from said first end, along a
channel axis from a point on said
lateral boundary of said chamber, to
said second end, said channel having a
25 radius R_1 at said first end and having
a radius R_2 at said second end, where
 R_1 is greater than R_2 ;

(b) a catheter having a central passage and
30 an entry port defining a flow path to said
central passage along a central axis, said
central passage having a radius R_2 ; and

-21-

(c) a coupling means for detachably
coupling said cannula and said entry port,
and for selectively establishing a
continuous flow path between said chamber
5 and said central passage with said channel
axis and said central axis being coaxial.

7. A vascular access system according to claim
6, wherein said coupling means includes a resilient
10 interface element disposed about and extending from
said entry port, wherein the extending portion of
said interface element is adapted to frictionally fit
over the outer surface of said second end of said
cannula,

15 whereby said walls defining said channel at
said second end and the inner surface of said central
passage establish a substantially smooth bounded flow
path.

20 8. A vascular access system according to claim
6, wherein said catheter has wirewound reinforced
sidewalls.

9. A vascular access system according to claim
25 6, wherein said end of said catheter opposite said
entry port is beveled.

10. A vascular access system according to claim
9, wherein said end of said catheter opposite said
30 entry port includes at least one lateral aperture
adjacent thereto.

11. A vascular access system according to claim 6, wherein said end of said catheter opposite said entry port includes at least one lateral aperture adjacent thereto.
- 5
12. A vascular access system according to claim 6 further comprising a non-coring needle adapted to selectively penetrate said septum.
- 10 13. A vascular access system according to claim 12, wherein said needle includes a trocar point and includes at least one lateral aperture near said point.
- 15 14. A vascular access system according to claim 12, wherein said needle includes a solid point and includes at least one lateral aperture near said point.
- 20 15. A vascular access system according to claim 12 wherein said needle includes a Huber point.
- 25 16. A vascular access system according to claim 6 wherein said housing comprises two or more internal openface chambers as defined in claim 1, each of said chambers having an affixed septum and an attached cannula as defined in claim 1.

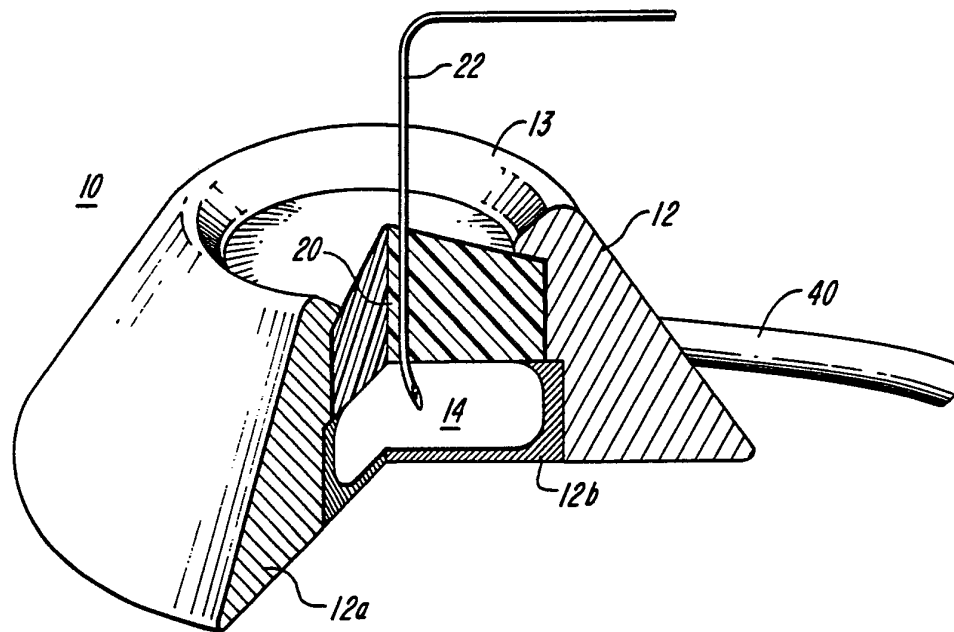

FIG. 1

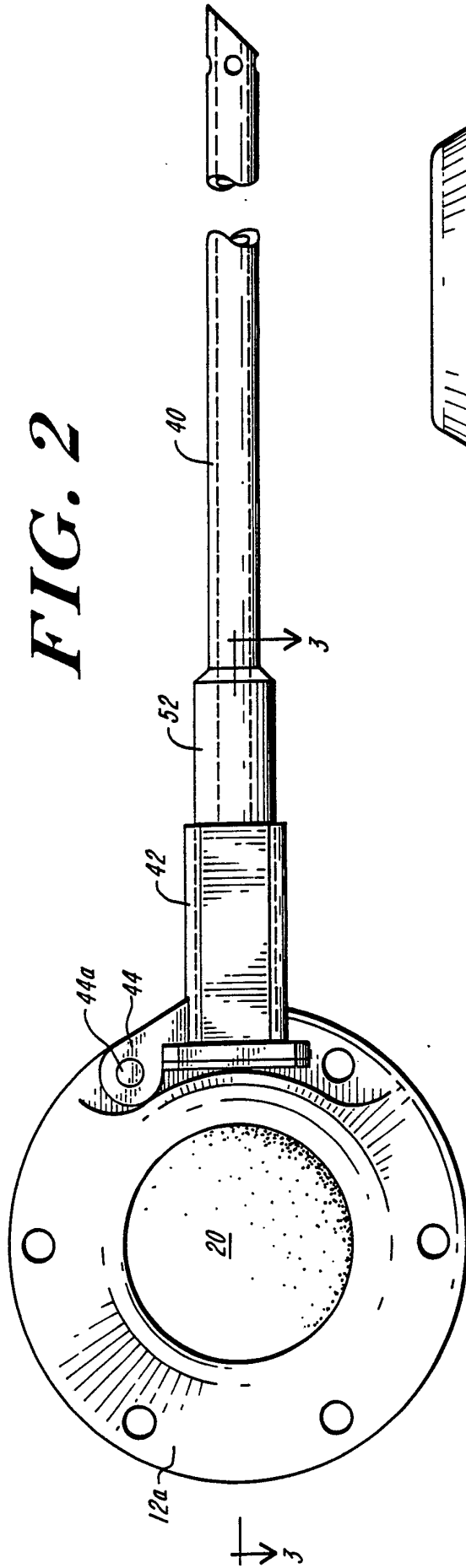

FIG. 2

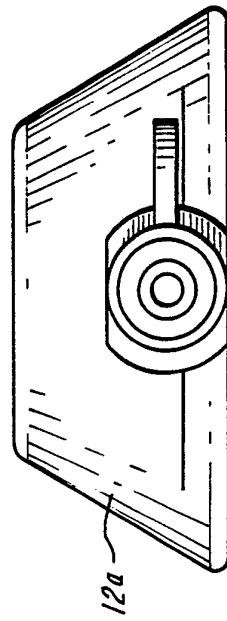

FIG. 4

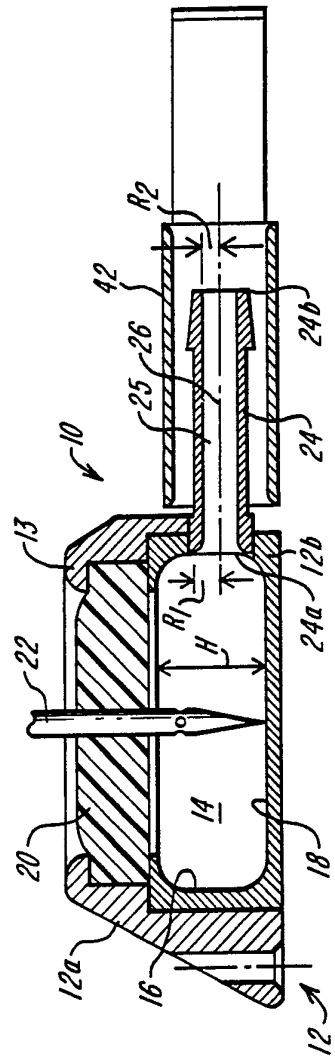

FIG. 3

3/5

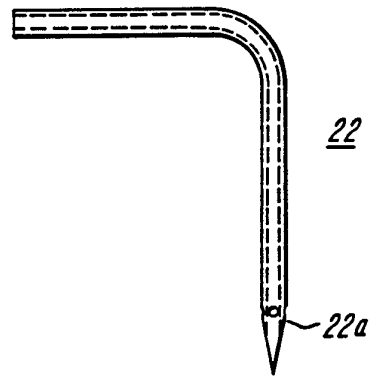

FIG. 5

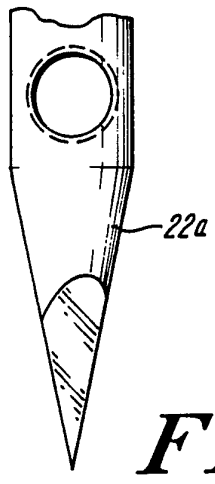

FIG. 6

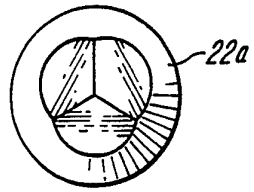

FIG. 7

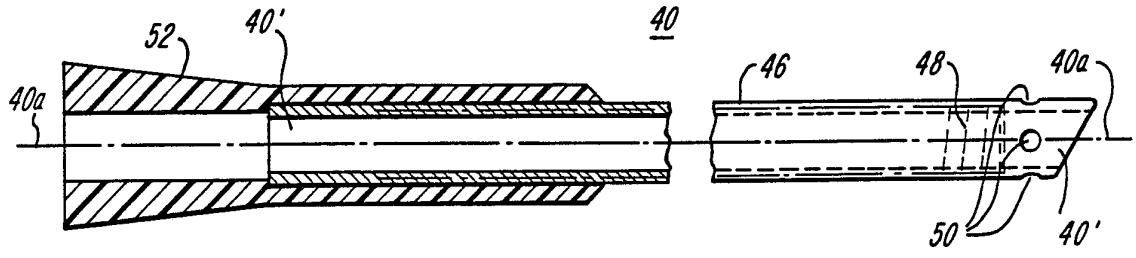

FIG. 8

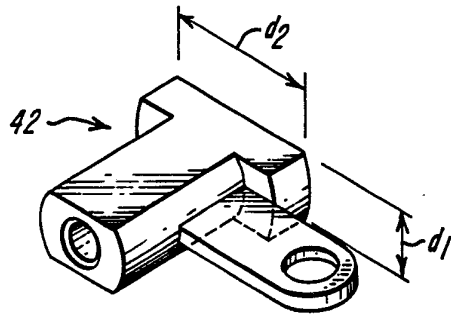

FIG. 9A

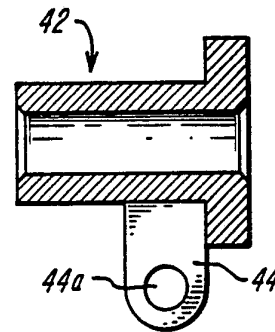

FIG. 9B

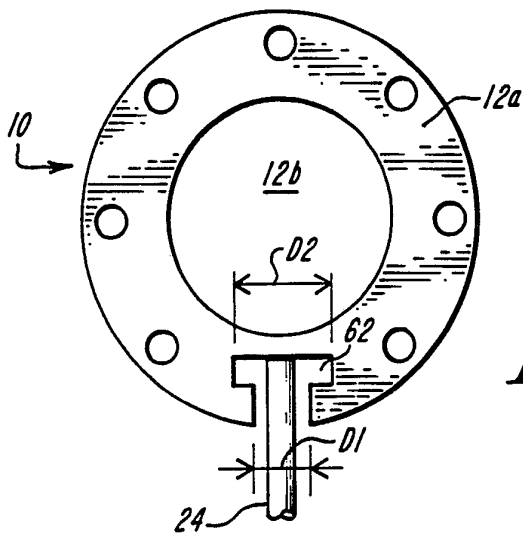

FIG. 10

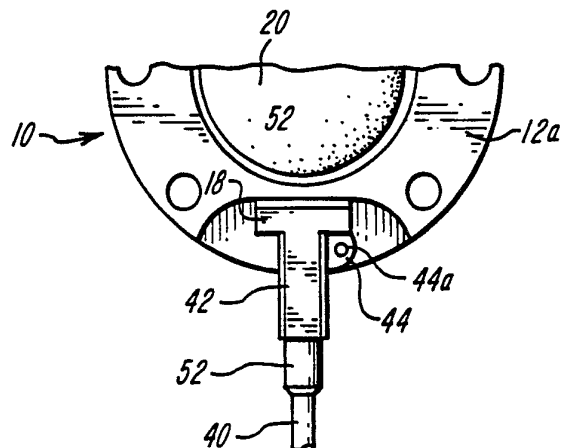

FIG. 11

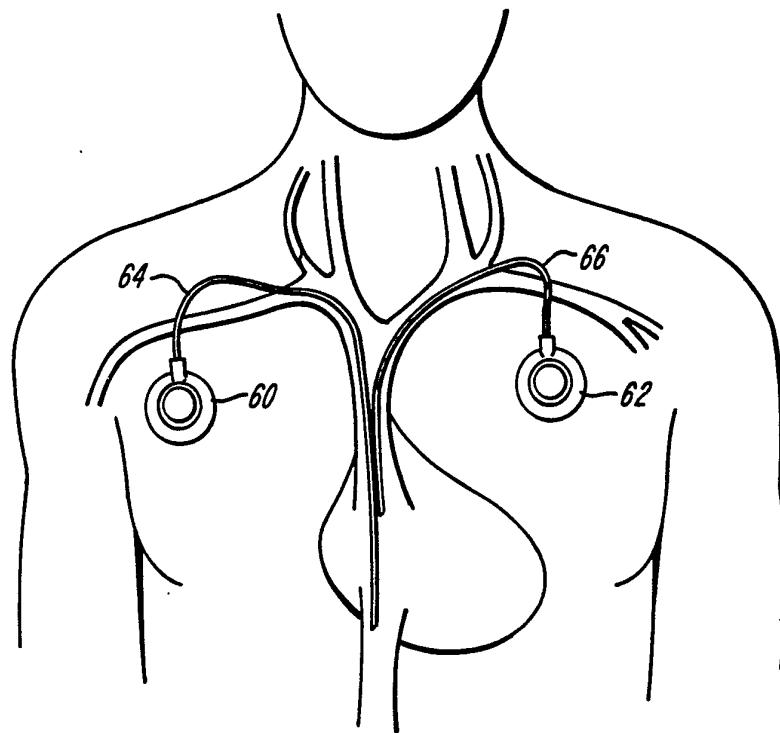

FIG. 12

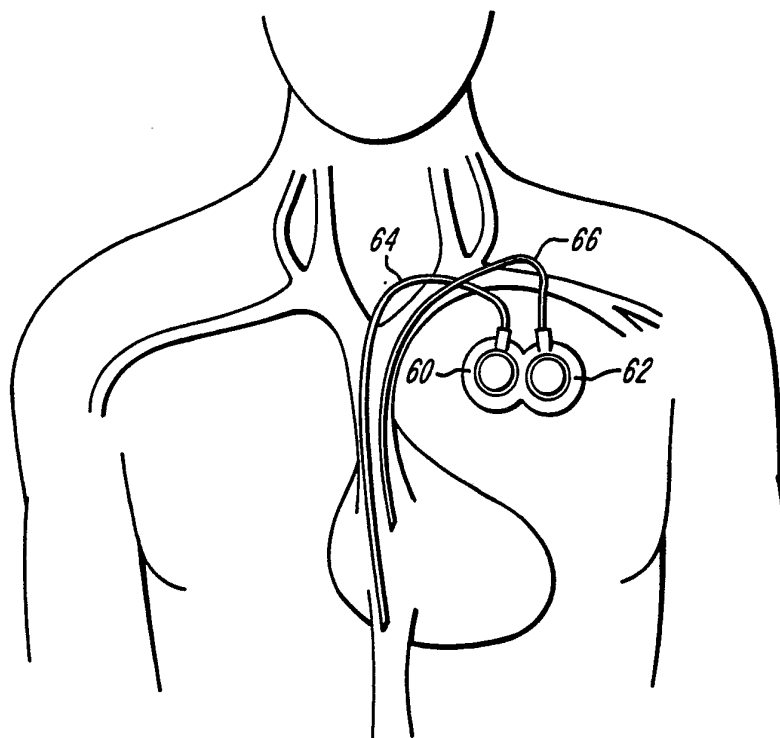

FIG. 13

INTERNATIONAL SEARCH REPORT

International Application No

PCT/US90/02681

I. CLASSIFICATION OF SUBJECT MATTER (if several classification symbols apply, indicate all) ³		
According to International Patent Classification (IPC) or to both National Classification and IPC		
IPC (5) :	A61M 5/32	
U.S. Cl :	604/175	
II. FIELDS SEARCHED		
Minimum Documentation Searched ⁴		
Classification System	Classification Symbols	
U.S.	604/4,8-10,85,86,93,131,132,140,174,175,185,244,283, 891.1,905	
Documentation Searched other than Minimum Documentation to the Extent that such Documents are Included in the Fields Searched ⁵		
III. DOCUMENTS CONSIDERED TO BE RELEVANT ¹⁴		
Category *	Citation of Document, ¹⁶ with indication, where appropriate, of the relevant passages ¹⁷	Relevant to Claim No. ¹⁸
<u>X</u> <u>Y</u>	US,A 3,490,438 (LAVENDER ET AL) 20 January 1970 See entire document.	<u>1,4,6,9,12</u> <u>2-3,5,7-8,</u> 10,11,13-16
Y	US,A 4,673,394 (FENTON, JR. ET AL) 16 June 1987 See abstract.	1-16
Y	US,A 4,692,146 (HILGER) 08 September 1987 See abstract.	1-16
A	US,A 4,704,103 (STOBER ET AL) 03 November 1987 See Figure 1.	1-16
A	US,A 4,772,270 (WIITA ET AL) 20 September 1988 See Figures 2 and 3.	1-16
(CON'T)		
<p>* Special categories of cited documents: ¹⁵</p> <p>"A" document defining the general state of the art which is not considered to be of particular relevance</p> <p>"E" earlier document but published on or after the international filing date</p> <p>"L" document which may throw doubts on priority claim(s) or which is cited to establish the publication date of another citation or other special reason (as specified)</p> <p>"O" document referring to an oral disclosure, use, exhibition or other means</p> <p>"P" document published prior to the international filing date but later than the priority date claimed</p>		<p>"T" later document published after the international filing date or priority date and not in conflict with the application but cited to understand the principle or theory underlying the invention</p> <p>"X" document of particular relevance; the claimed invention cannot be considered novel or cannot be considered to involve an inventive step</p> <p>"Y" document of particular relevance; the claimed invention cannot be considered to involve an inventive step when the document is combined with one or more other such documents, such combination being obvious to a person skilled in the art.</p> <p>"&" document member of the same patent family</p>
IV. CERTIFICATION		
Date of the Actual Completion of the International Search ²	Date of Mailing of this International Search Report ²	
25 JULY 1990	<div style="font-size: 1.5em; font-weight: bold; margin: 0;">12 SEP 1990</div>	
International Searching Authority ¹	Signature of Authorized Officer ²⁰	
ISA/US	<div style="font-weight: bold; margin: 0;">RALPH LEWIS</div>	

FURTHER INFORMATION CONTINUED FROM THE SECOND SHEET

A	US,A 4,781,680 (REDMOND ET AL) 01 November 1988 See abstract.	1-16
Y,P	US,A 4,892,518 (CUPP ET AL) 09 January 1990 See Column 3, Line 40; Column 7, Line 25.	1-16

V. OBSERVATIONS WHERE CERTAIN CLAIMS WERE FOUND UNSEARCHABLE¹

This international search report has not been established in respect of certain claims under Article 17(2) (a) for the following reasons:

1. Claim numbers _____, because they relate to subject matter not required to be searched by this Authority, namely:

2. Claim numbers _____, because they relate to parts of the international application that do not comply with the prescribed requirements to such an extent that no meaningful international search can be carried out¹, specifically:

3. Claim numbers _____, because they are dependent claims not drafted in accordance with the second and third sentences of PCT Rule 6.4(a).

VI. OBSERVATIONS WHERE UNITY OF INVENTION IS LACKING²

This International Searching Authority found multiple inventions in this international application as follows:

1. As all required additional search fees were timely paid by the applicant, this international search report covers all searchable claims of the international application.
2. As only some of the required additional search fees were timely paid by the applicant, this international search report covers only those claims of the international application for which fees were paid, specifically claims:

3. No required additional search fees were timely paid by the applicant. Consequently, this international search report is restricted to the invention first mentioned in the claims; it is covered by claim numbers:

4. As all searchable claims could be searched without effort justifying an additional fee, the International Searching Authority did not invite payment of any additional fee.

Remark on Protest

- The additional search fees were accompanied by applicant's protest.
 No protest accompanied the payment of additional search fees.