

(19) World Intellectual Property Organization  
International Bureau



(43) International Publication Date  
22 September 2011 (22.09.2011)

(10) International Publication Number  
**WO 2011/115968 A1**

- (51) International Patent Classification:  
*B26B 19/40* (2006.01)     *B26B 21/44* (2006.01)
- (21) International Application Number:  
PCT/US2011/028482
- (22) International Filing Date:  
15 March 2011 (15.03.2011)
- (25) Filing Language: English
- (26) Publication Language: English
- (30) Priority Data:  
61/340,289     15 March 2010 (15.03.2010)     US
- (71) Applicant (for all designated States except US): **THE GILLETTE COMPANY** [US/US]; World Shaving Headquarters, IP/Legal Patent Department - 3E, One Gillette Park, Boston, MA 02127 (US).
- (72) Inventors; and
- (75) Inventors/Applicants (for US only): **JOLLEY, William, Owen** [US/US]; 225 Charlton Road, Spencer, MA 01562 (US). **ROCKELL, Barry, Keith** [GB/GB]; 1 Dartmouth

Close, Bracknell Berkshire RG12 9HG (GB). **SALEMME, James, Leo** [US/US]; 10 Governor Hutchinson Road, Billerica, MA 01821 (US).

(74) Common Representative: **THE GILLETTE COMPANY**; c/o Eileen L. Hughett, The Procter & Gamble Company, Global Patent Services, 299 East Sixth Street, Sycamore Building, 4th Floor Cincinnati, OH 45202 (US).

(81) Designated States (unless otherwise indicated, for every kind of national protection available): AE, AG, AL, AM, AO, AT, AU, AZ, BA, BB, BG, BH, BR, BW, BY, BZ, CA, CH, CL, CN, CO, CR, CU, CZ, DE, DK, DM, DO, DZ, EC, EE, EG, ES, FI, GB, GD, GE, GH, GM, GT, HN, HR, HU, ID, IL, IN, IS, JP, KE, KG, KM, KN, KP, KR, KZ, LA, LC, LK, LR, LS, LT, LU, LY, MA, MD, ME, MG, MK, MN, MW, MX, MY, MZ, NA, NG, NI, NO, NZ, OM, PE, PG, PH, PL, PT, RO, RS, RU, SC, SD, SE, SG, SK, SL, SM, ST, SV, SY, TH, TJ, TM, TN, TR, TT, TZ, UA, UG, US, UZ, VC, VN, ZA, ZM, ZW.

[Continued on next page]

(54) Title: HAIR REMOVAL DEVICE

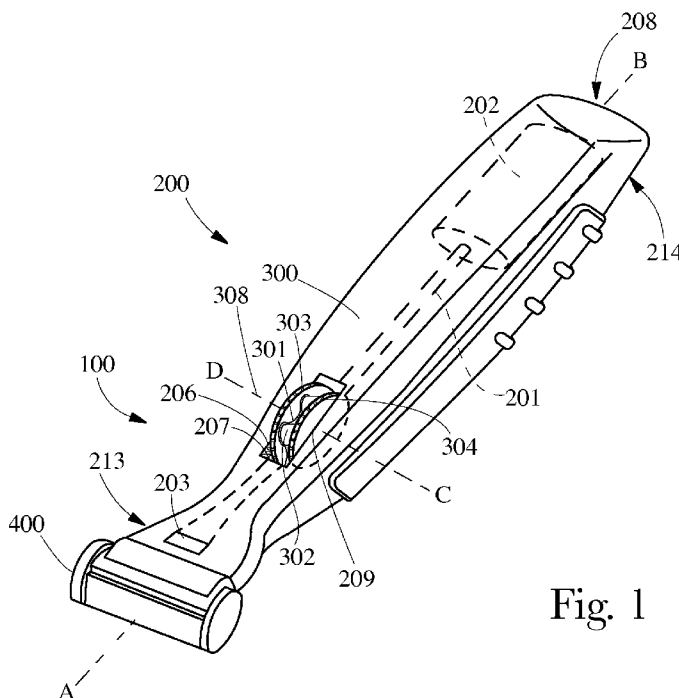

Fig. 1

(57) Abstract: The invention features a hair removal device that dispenses fluid during operation. The hair removal device includes a handle and a device head operably engaged thereto. The handle has a proximal end forming a product dispensing aperture, a distal end forming a cavity for housing a fluid, a supply channel in fluid communication with the cavity and the product dispensing aperture, a peristaltic pump physically engaged with the supply channel. Actuation of the peristaltic pump displaces fluid from the cavity to the product dispensing aperture.

WO 2011/115968 A1



**(84) Designated States** (*unless otherwise indicated, for every kind of regional protection available*): ARIPO (BW, GH, GM, KE, LR, LS, MW, MZ, NA, SD, SL, SZ, TZ, UG, ZM, ZW), Eurasian (AM, AZ, BY, KG, KZ, MD, RU, TJ, TM), European (AL, AT, BE, BG, CH, CY, CZ, DE, DK, EE, ES, FI, FR, GB, GR, HR, HU, IE, IS, IT, LT, LU, LV, MC, MK, MT, NL, NO, PL, PT, RO, RS, SE, SI, SK,

SM, TR), OAPI (BF, BJ, CF, CG, CI, CM, GA, GN, GQ, GW, ML, MR, NE, SN, TD, TG).

**Published:**

— *with international search report (Art. 21(3))*

## HAIR REMOVAL DEVICE

## BACKGROUND OF THE INVENTION

Liquid dispensing hair removal devices, such as razors, are known. For example, razors that dispense liquid have been disclosed in U.S. Patent 4,653,188, U.S. Patents 5,701,674 and 5,070,611, and U.S. Applications 2009/0235530, 2009/0211099, 2009/0183371, 2008/0216322, and 2006/0272154. Disclosed in these and other publications are various wet shaving product configurations that include systems for conveying a shaving preparation during shaving, e.g., a lubricating fluid, from a reservoir incorporated in the razor structure in the form of a hollowed out razor handle or even an aerosol can that acts as a razor handle, to a dispensing location near the head of the razor. A number of more recent wet shaving razors have cartridges that are moveably mounted, in particular, pivotable, relative to the handle structures on which they are mounted either permanently, in the case of disposable safety razors intended to be discarded when the blade or blades have become dulled, or detachably to allow replacement of the blade unit on a reusable handle structure. Exemplary razors of this sort are disclosed in U.S. Patents 6,789,321 and 7,127,817.

Additionally, the use of movable actuators to dispense liquid from the razor is known. Examples of razors utilizing peristaltic pumps are disclosed in U.S. Applications 2006/0289031 and 2008/0016692. However, many of these wet razors that dispense liquid during use are awkward to operate and cumbersome to hold because of the size and shape needed to accommodate a peristaltic pump. Some of these devices require the mechanism for dispensing the liquid to be reset after every operation of the device. Moreover, some even require multiple parts and electrical power from a wall outlet, limiting the portability of the hair removal device. Furthermore, with multiple parts, when stored and during operation, these hair removal devices occupy valuable space in bathrooms that are typically limited in size. Additionally, most peristaltic pumps contain a rotor with rollers attached thereto. Smaller peristaltic pumps, however, requires nodes or nubs on a rotor, rather than rollers, like those disclosed in U.S. Patents 5,098,261 and 4,025,241, and GB 2,270,300. When rotated, the nodes or nubs tend to pull and/or tug on the tube transporting the liquid. This pulling and tugging by the smaller peristaltic pumps is believed to cause displacement of the tube, as well as wear and tear on the material of the tube, ultimately reducing the life of the device.

A need therefore exists to provide a razor that overcomes one or more of the aforementioned problems.

#### SUMMARY OF THE INVENTION

One aspect of the present invention provides a hair removal device for dispensing a liquid during the hair removal operation. The hair removal device comprises a handle and a device head that is operably connected to the handle. Hair removal can be by shaving with a razor or other hair removal technology, such as depilatories. The handle comprises a proximal end that forms a product dispensing aperture and a distal end, opposite of the proximal end, that forms a cavity for housing a fluid disposed within the handle. The product dispensing aperture in the proximal end of the handle is in fluid communication with the cavity in the distal end of the handle via a supply channel. Additionally, a peristaltic pump is positioned between the proximal end and the distal end of the handle. The peristaltic pump comprises a rotating actuator that is physically engaged with the supply channel and configured to transport fluid from the vicinity of the cavity to the product dispensing aperture when triggered. In one embodiment, a flexible barrier exists between the rotating actuator and the supply channel, allowing the rotating actuator to indirectly engage the supply channel. Furthermore, in another embodiment, the actuator is equipped with a ratchet system, limiting the actuator has a unidirectional rotation, allowing only fluid to move out of the cavity and through the aperture.

In another embodiment, the rotating actuator on the peristaltic pump comprises at least two nodes. At least one of these at least two nodes is in contact with the supply channel forming a pinch point. At least one of the nodes forms a pinch point with the supply channel throughout the rotation of the rotating actuator.

In yet another embodiment, the invention features a rotating actuator with a central axis and a maximum radial movement of up to about 15 mm. In one embodiment, the device further comprises a channel in the handle, allowing for the movement of the rotating actuator within the channel. Furthermore, a notch may be located along the channel, indicating the central axis of the peristaltic pump. Additionally, a spring may be attached to the peristaltic pump allowing it to return to its central axis after it has been moved within the channel.

Other features and advantages of the invention will be apparent from the description and drawings, and from the claims. Methods of using said device are also provided.

### BRIEF DESCRIPTION OF THE DRAWINGS

FIG. 1 is a perspective view of a hair removal device of the present invention;  
FIG. 2 is a side view of one embodiment of the peristaltic pump;  
FIG. 3 is a side view of another embodiment of the peristaltic pump;  
FIG. 4 is an exploded view of one embodiment of the peristaltic pump and supply channel;  
FIG. 5 is a frontal view of one embodiment of the peristaltic pump.

### DETAILED DESCRIPTION OF THE INVENTION

FIGS. 1-5 show a hair removal device (100) capable of dispensing fluid during the hair removal process (such as shaving), comprising, a peristaltic pump (300), and a device head (400). The device head (400) may be a shaving cartridge, which includes a guard and an elastomeric member disposed on the guard, or a scraping surface. Nonlimiting examples of suitable device heads are disclosed in U.S. Patents 7,197,825, 6,298,558, 6,161,288.

FIG. 1 provides a perspective view of the hair removal device (100). The handle (200) has a proximal end (213) and a distal end (212) and is adapted to hold a device head (400). The device head (400) may be permanently affixed on handle (200), or may be releasably engaged from the handle (200). Nonlimiting examples of suitable handles are disclosed in U.S. Patent D533,684, U.S. Patent 5,918,369, and U.S. Patent 7,168,173. This disengagement of these two components allows for replacement of razor cartridges as the continued use of such cartridges causes blade dulling. Thus, such cartridges are replaceable and disposable at will by the user.

As shown in FIG. 1, the handle (200) comprises a cavity (202) for housing a fluid disposed within the distal end (212) of the handle (200) and a product dispensing aperture (203) formed within the proximal end (213) of the handle (200). The cavity (202) and the product dispensing aperture (203) are in fluid communication with each other via a supply channel (201). The supply channel (201) is configured to transport fluid out of the cavity (202) and through the product dispensing aperture (203). Furthermore, the handle (200) contains a peristaltic pump (300) located along the handle between the distal end (212) and the proximal end (213) and physically engaged with the supply channel (201). Actuation of the peristaltic pump (300) displaces fluid from the cavity (202) through the supply channel (201), and eventually through the product dispensing aperture (203).

The cavity (202), or a removable pouch/container within the cavity (205) as shown in FIG. 4, contains the fluid to be dispensed during hair removal. In an embodiment, the fluid in the cavity (202) or removable pouch (205) is refillable or replaceable. The removable pouch (205) may have multiple chambers that allow fluids to mix upon being dispensed. The fluid may include shaving gels, shaving foams, shaving lotions, skin treatment compositions, conditioning aids, depilatories, lotions, moisturizers, etc., all which may be used to prepare the skin's surface prior to the engagement of the device head with the skin or even after engagement of the device head with the skin. Additionally, such materials may comprise benefit agents suitable for skin and/or hair that may be useful for a number of different desirable effects including exfoliation, cooling effects, cleansing, moisturizing, warming or thermogenic effects, conditioning, and the like. Nonlimiting examples of suitable benefit agents for skin and/or hair for inclusion into the fluid of the razor are disclosed in U.S. Patent 6,789,321. For instance, suitable agents include but are not limited to shaving soaps, lubricants, skin conditioners, skin moisturizers, hair softeners, hair conditioners, fragrances, skin cleansers, bacterial or medical lotions, blood coagulants, anti-inflammatories, astringents, and combinations thereof. In certain embodiments, such as that shown in FIG. 4, the fluid may be contained in a removable pouch (205), either disposable or reusable, that is further contained within the cavity (202) of the handle (200).

FIG. 2 provides a side view of one embodiment of the peristaltic pump (300). The peristaltic pump (300) comprises a rotating actuator (301), such as a wheel, nodes (302), such as nubs, disposed on the actuator (301), and is rotatably engaged with the supply channel (201). The peristaltic pump (300) activates fluid flow from the cavity (202) through the supply channel (201), and out the product dispensing aperture (203) by means of peristalsis. Without intending to be bound by theory, it is believed that peristalsis is the consecutive contraction of the walls of a tube-like structure, causing the contents within the tube-like structure to displace through the tube-like structure. The rotating actuator (301) utilizes nodes (302) instead of pump rollers, like those disclosed in U.S. Patents 5,098,261 and 4,025,241, and U.K. Application GB 2,270,300, to contract the walls of the supply channel (201) and move the volume of fluid up to the product dispensing aperture (203). Furthermore, it is believed that by minimizing the amount of movable parts, the peristaltic pump (300) has less of a chance of malfunctioning from a broken part. When the actuator (301) rotates, the nodes (302) attached to the actuator (301) rotate with the actuator (301), contacting the supply channel (201) by pinching the supply channel (201),

creating a pinch point as shown in FIG. 2. As the actuator (301) continues to rotate, the pinch point travels along the supply channel (201) in the direction of rotation. The combination of the node (302) and the pinch point directs any fluid in the supply channel (201) through the supply channel (201), while simultaneously allowing fluid to enter the supply channel (201) from the cavity (202). The directed fluid flows through the supply channel (201) in the direction of rotation of the rotating actuator (301) and nodes (302). Furthermore, the pinch point serves a dual purpose. While it directs fluid through the supply channel (201) and out the product dispensing aperture (203), the pinch point additionally serves as a shut off valve for the cavity (202). Acting as a shut off valve, the pinch point prevents contaminated fluid from re-entering the cavity (202), or moving back in the flow path. Once fluid becomes exposed to the outer environment, it poses a risk of becoming contaminated with debris and bacteria. Allowing contaminated fluid into the cavity of the handle could potentially contaminate the remaining fluid in the cavity (202), aiding microbial growth in both the cavity (202) and supply channel (201).

Furthermore, as shown in FIGs. 2 and 5, a contact wheel (303) may be rotatably attached to the actuator (301), allowing a user to manually turn the actuator (301) with the motion of a finger. The contact wheel may contain textured surface (304) allowing easy grip and a comfortable texture for the user. The textured surface (304) on the contact wheel (303) may resemble the grooves on a quarter, or may be spaced farther apart. In most instances, the peristaltic pump (300) may be actuated by the pressure exerted by a user's finger on the contact wheel (303) such that the user may easily determine the requisite amount of fluid for one operation of the hair removal device (100). Because the rotating actuator (300) contains at least two nodes (302), and when rotated, the nodes (302) push sections of fluid through the supply channel (201), the fluid can be consistently dispensed in controlled and metered quantities based on the amount of rotation of the rotating actuator (301).

Additionally, the contact wheel (303), along with the actuator (301) may be positioned to have various axes of rotation. In one embodiment, the contact wheel (303) and the actuator (301) rotate around an axis substantially parallel to the proximal-distal axis (208) of the handle (200), within about 0 to 30 degrees from parallel of the proximal-distal axis (208) of the handle (200). In another embodiment, as shown in FIG. 1, the contact wheel (303) and the actuator (301) rotate around an axis substantially perpendicular to the proximal-distal axis (208) of the handle (200), within about 0 to 30 degrees from perpendicular to the proximal distal axis (208)

of the handle (200). The different rotatable axes may allow flexibility in what is more comfortable to the user. The rotation of the contact wheel (303) and the rotating actuator (301) around the substantially parallel axis enables the user to actuate the peristaltic pump (300) by moving their thumb, or other fingers, across the width of the handle (200). Furthermore, the rotation of the contact wheel (303) and the rotating actuator (301) around the substantially perpendicular axis enables the user to actuate the peristaltic pump (300) by moving their thumb, or other fingers down the length of the handle (200). Users may find the motion of moving their thumb, or other fingers, across the width of the handle (200) more natural than swiping their thumb, or other fingers, down the length of the handle (200).

In an embodiment shown in FIG. 2 of the side view of the peristaltic pump (300), a flexible barrier (305) may exist between the supply channel (201) and the actuator (301). The flexible barrier (305) prevents the nodes (302) from tugging, pulling, and/or stretching on the supply channel (201), keeping the supply channel (201) in the same location and preventing wear on the material of the supply channel (201). In one embodiment, the peristaltic pump (300) contains nodes/nubs (302) along the rotating actuator (301). Because these nodes (302) are stationary, and do not rotate independently of the rotating actuator (301) as pump rollers would, the nodes (302) are pressed into and dragged across the supply channel (201) to produce a peristalsis effect. The dragging of stationary nodes (302) is believed to create a potentially undesirable amount of friction between the nodes (302) and the supply channel (201). It is believed that this amount of friction may have wear and tear effects on the supply channel (201).

One possible effect on the supply channel (201) is the eventual deformation of the supply channel (201) material, potentially wearing down the supply channel (201) prematurely. A second possible effect on the supply channel (201) is pulling or tugging of the supply channel (201) by the nodes (302). This is believed to cause the supply channel (201) to reposition within the handle (200), having many potentially undesirable consequences on the hair removal device (100). One potential consequence includes the repositioning the supply channel (201) to where it becomes disengaged with the rotating actuator (301), preventing the nodes (302) from forming a pinch point. If this were to occur, the nodes (302) would not be to direct fluid through the supply channel (201). Another potential outcome from the supply channel (201) repositioning due to friction with the nodes (302) would be disconnection of the supply channel (201) from the either the cavity (202) or the product dispensing aperture (203). If the supply channel (201)



disconnected from either of these two elements, the performance of hair removal device (100) could be hindered.

Additionally, the barrier (305), shown in FIG. 2, may be made of a deformable thermoplastic material allowing deformation of the barrier (305) by the nodes (302), which in turn, allow the nodes (302) to indirectly create a pinch point in the supply channel (201). Because the barrier (305) is in direct contact with the rotating nodes (302), the flexible barrier (305) should be made of low friction material, such as polytetrafluoroethylene or polyethylene terephthalate. An acceptable static coefficient of friction of the flexible material may be less than 0.3, while an acceptable dynamic coefficient of friction may be less than 0.45. In one embodiment, the coefficient of friction for the flexible barrier (305) may be in the range of about 0.05 to 0.10. An acceptable thickness of the flexible barrier (305) may be between about 0.15 mm and 1.2 mm, or may be between about 0.5 mm and 1.0 mm. A thickness within this range of most thermoplastic materials may provide an appropriate amount of deformation for the node (302) of the rotating actuator (301) to indirectly create a pinch point in the supply channel (201). If the flexible material is too thick, proper deformation may not occur, resulting in a loss of the peristalsis effect in the supply channel (201). Moreover, a flexible barrier (305) too thin may not guard the supply channel (201) from the flexible barrier's designed beneficial effects.

In another embodiment, the device comprises a ratchet mechanism (306), which reduces the rotation of the actuator (301) to unidirectional rotation. FIG. 3 shows a side view of an embodiment of the peristaltic pump (300) with a ratchet mechanism (306). Those of ordinary skill in the art will understand that, in embodiments where the actuator rotates (301) about an axis is perpendicular to the proximal-distal axis (208) of the handle, the direction of the rotation can be clockwise towards the razor head or counter clockwise away from the razor head. In embodiments where the actuator (301) rotates about an axis is parallel to the proximal-distal axis (208) of the handle (200), the direction of rotation can be clockwise to the right of the handle (200) or counter clockwise to the left of the handle (200). The ratchet mechanism (306) shown in FIG 3 may use the contact wheel's textured surface (304) to prevent the actuator (301) from rotating in a direction that would pump fluid into the cavity (202). Multiple uses of the textured surface (304) minimizes the amount of parts in the hair removal device (100). However, the ratchet grooves (309) may be recessed below the textured surface (304) of the contact wheel (303) to provide more comfort to the user. Using the textured surface (304) as part of the ratchet mechanism (306) may be unpleasant to the user because of the drastic groove angles with

respect to the circumferential surface of the contact wheel (303). Furthermore, while the textured surface (304) may still be comfortable to the user upon first use of the hair removal device (100), the textured surface (304) may wear down over time from the ratchet mechanism to become unpleasant feeling to the user. Therefore, in one embodiment the peristaltic pump comprises separate ratchet mechanism grooves (309) and textured surface (304), like that shown in FIG. 5. FIG. 3 shows a securing member (310), which secures the ratchet mechanism (306) in place during rotation of the actuator (301). The ratchet mechanism (306) may constrain the actuator (301) to rotate in a direction that would dispense fluid from the cavity (202), through the supply channel (201), and out the product dispensing aperture (203).

FIG. 1 shows yet another embodiment, where the peristaltic pump (300) may have radial movement along the length of the handle (200) of up to about 15 mm, 10 mm, 5 mm, or 0 mm. This radial movement allows the peristaltic pump (300), including the contact wheel (303), to move with the user's finger when triggered. During this radial movement, the rotating actuator (301) of the peristaltic pump (300) stays in constant contact with the supply channel (201) and/or flexible barrier (305) because of the configuration and flexibility of the supply channel (201) and/or flexible barrier (305). The radial movement provides the user with more control over the peristaltic pump (300) because the contact wheel (303) travels with the user's finger when actuated. This results in less actuation by the user to achieve the desired amount of fluid from the hair removal device (100). Additionally, the radial movement of the peristaltic pump (300) may provide more control to the user. Furthermore, the handle may have a channel (206), as shown in FIG. 1, guiding the movement of the peristaltic pump (300) when the peristaltic pump (300) is actuated. The peristaltic pump (300) may have a central axis (308) along the channel, providing a resting position for the peristaltic pump (300) when not actuated. The channel (206) may be equipped with a notch (209) serving as the peristaltic pump's central axis (308), which the peristaltic pump (300) lays when not actuated. Additionally, the channel (206) may also be equipped with one or more springs (207) that return the peristaltic pump (300) to the central axis (308). Because users often shave early in the morning or late at night, when there is little light and when they may not be fully awake, the central axis (308) enables the user to easily find the contact wheel (303) without looking when picking up the hair removal device (100).

The invention may further contain a nozzle (204) attached to the product dispensing aperture (203) for dispensing the fluid onto a variety of surfaces. These various surfaces may

include the guard of a shaving cartridge, the skin of the user, or a combination of the two. The nozzle (204) may extend from the product dispensing aperture (203) to the guard of a shaving cartridge and be shaped for equal distribution of the fluid onto the guard. Moreover, the handle may further include a closure (211) that allows access to the cavity (202) for cleaning and refilling with the fluid, or removing a sachet or pouch (205). The closure (211) may be a cap that screws onto the handle (200), a cap that slidably engages with the handle (200), or a panel that opens on the handle (200). Furthermore, the peristaltic pump (300) may be electrically actuated rather than manually actuated. The handle (200) may contain a small electric motor (307) connected to the peristaltic pump (300) described above. The user may simply turn the electric motor (307) on and off to control the amount of fluid pumped from the cavity (202) during operation of the hair removal device (100). The electric motor (307) enables the user to dispense fluid during operation of the hair removal device (100) with minimal effort compared to the manual actuation of the peristaltic pump (300).

A method for using the hair removal device (100) comprises actuating the peristaltic pump (300) to dispense fluid from the cavity (202) through the product dispensing aperture (203), dispensing fluid onto a surface for hair removal, and removing hair from the surface via the hair removal device (100).

It should be understood that every maximum numerical limitation given throughout this specification includes every lower numerical limitation, as if such lower numerical limitations were expressly written herein. Every minimum numerical limitation given throughout this specification includes every higher numerical limitation, as if such higher numerical limitations were expressly written herein. Every numerical range given throughout this specification includes every narrower numerical range that falls within such broader numerical range, as if such narrower numerical ranges were all expressly written herein.

All parts, ratios, and percentages herein, in the Specification, Examples, and Claims, are by weight and all numerical limits are used with the normal degree of accuracy afforded by the art, unless otherwise specified.

The dimensions and values disclosed herein are not to be understood as being strictly limited to the exact numerical values recited. Instead, unless otherwise specified, each such dimension is intended to mean both the recited value and a functionally equivalent range surrounding that value. For example, a dimension disclosed as "40 mm" is intended to mean "about 40 mm".

All documents cited in the DETAILED DESCRIPTION OF THE INVENTION are, in the relevant part, incorporated herein by reference; the citation of any document is not to be construed as an admission that it is prior art with respect to the present invention. To the extent that any meaning or definition of a term or in this written document conflicts with any meaning or definition in a document incorporated by reference, the meaning or definition assigned to the term in this written document shall govern.

Except as otherwise noted, the articles "a," "an," and "the" mean "one or more."

While particular embodiments of the present invention have been illustrated and described, it would be obvious to those skilled in the art that various other changes and modifications can be made without departing from the spirit and scope of the invention. It is therefore intended to cover in the appended claims all such changes and modifications that are within the scope of this invention.

What is claimed is:

1. A hair removal apparatus (100) comprising:
  - a. a handle (200) comprising
    - i. a proximal end (213) forming a product dispensing aperture (203);
    - ii. a distal end (212), opposite said proximal end (213), said distal end (212) forming a cavity (202) for housing a fluid (214) disposed within said handle (200), wherein said product dispensing aperture (203) and said cavity (202) are in fluid communication via a supply channel (201);
    - iii. a peristaltic pump (300) disposed on said handle (200) between said proximal end (213) and said distal end (212), said peristaltic pump (300) comprising:
      1. a rotating wheel (301) physically engaged with said supply channel (201), wherein rotation of rotating actuator (301) directs said fluid (214) from the vicinity of the cavity (202) to said product dispensing aperture (203) via said supply channel (201), and said rotating wheel (301) has a rotatable axis perpendicular to a central traverse axis of said handle (200);
      2. at least two nodes (302) disposed onto said rotating wheel (301) wherein at least one of said at least two nodes (302) is in contact with the supply channel (201) to form a pinch point (210);
      3. wherein at least one of said at least two nodes (302) forms said pinch point (210) with said supply channel (201) throughout the rotation of said rotating wheel (301); and
  - b. a shaving cartridge (400), operably connected to said proximal end (213).
2. The hair removal apparatus according to claim 1, wherein said rotating wheel (301) is manually rotatable.
3. The hair removal apparatus according to claim 1 or 2, further comprising an electric motor (307) that drives said rotating wheel (301) causing said rotating wheel (301) to rotate.

4. The hair removal apparatus according to any preceding claim, further comprising a ratchet mechanism (306), wherein the ratchet mechanism (306) reduces the rotation of said rotating wheel (301) to a unidirectional rotation.
5. The hair removal apparatus according to any preceding claim, further comprising a contact wheel (303) extending out from said handle (200) and is rotatably communicated with said rotating wheel (301).
6. The hair removal apparatus according to any preceding claim, wherein said contact wheel (303) rotates along an axis parallel to a proximal-distal axis (208) of said handle (200).
7. The hair removal apparatus according to any preceding claim, wherein said contact wheel (303) rotates along an axis perpendicular to a proximal-distal axis (208) of said handle (200).
8. The hair removal apparatus according to any preceding claim, wherein said pinch point (210) serves as a shut off valve, preventing back flow into said supply channel (201).
9. The hair removal apparatus according to any preceding claim, wherein said cavity (202) comprises a removable pouch (205).
10. The hair removal apparatus according to any preceding claim, further comprising a flexible barrier (305) positioned between said rotating actuator (301) and said supply channel (201).
11. The hair removal apparatus according to any preceding claim, wherein the rotating actuator (301) comprises an central axis (308) which has a maximum radial movement of the rotating actuator.

1/3

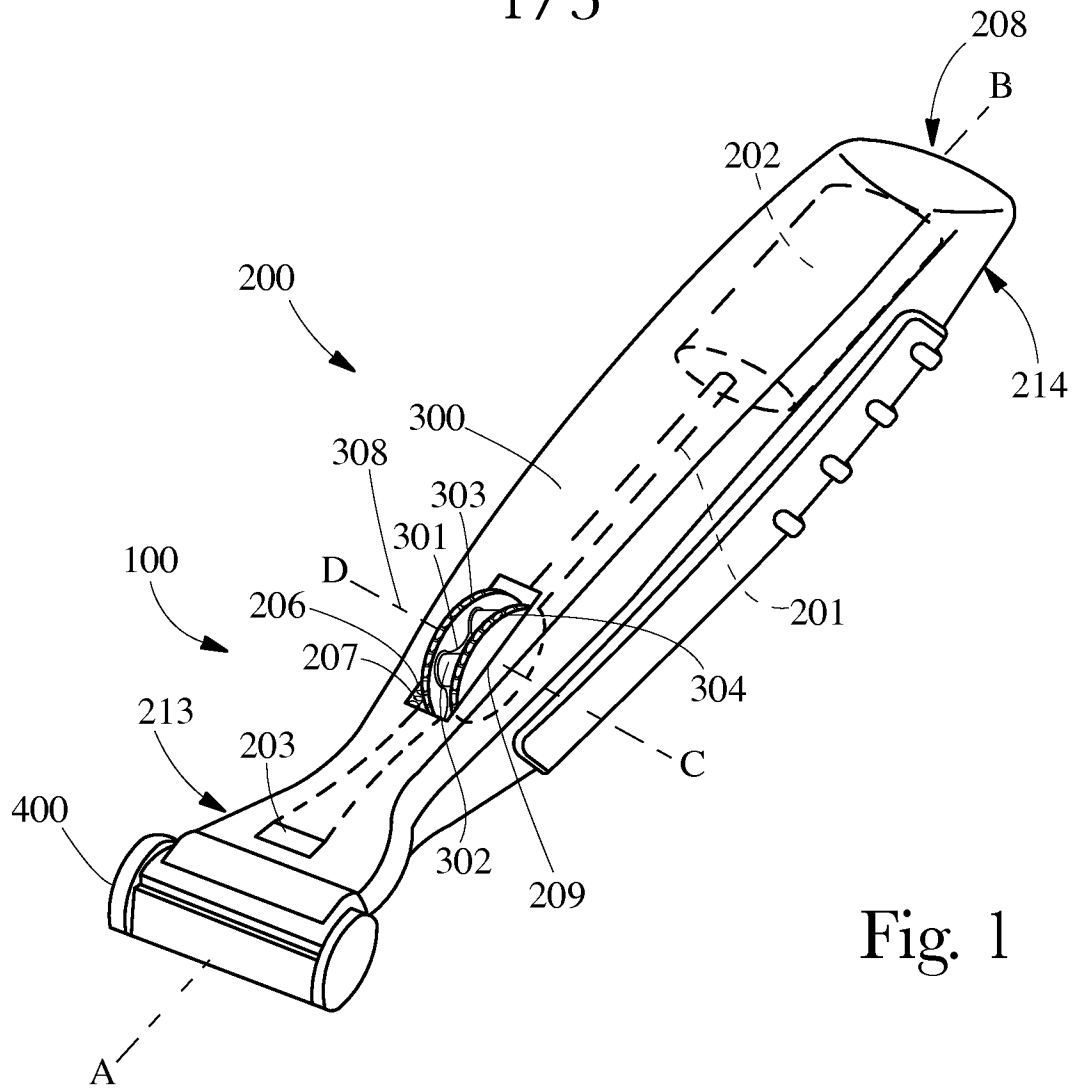

Fig. 1

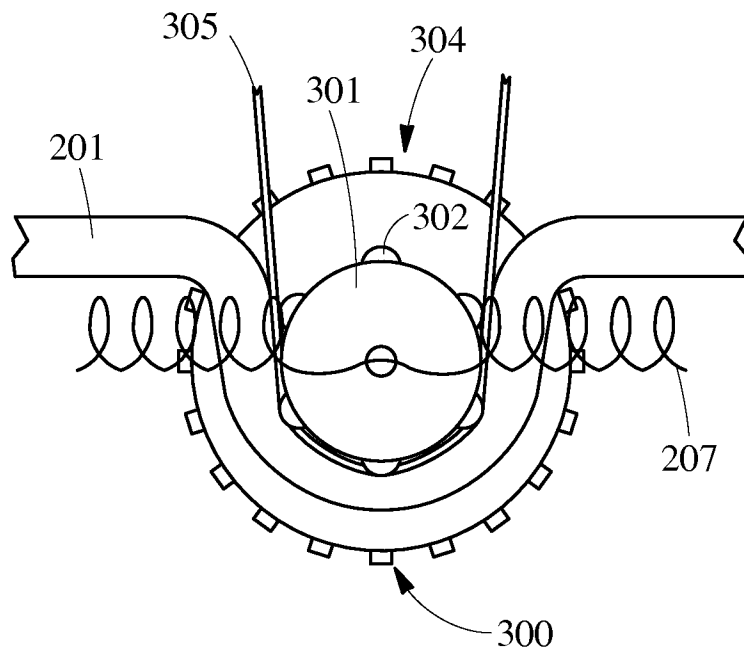

Fig. 2

2/3

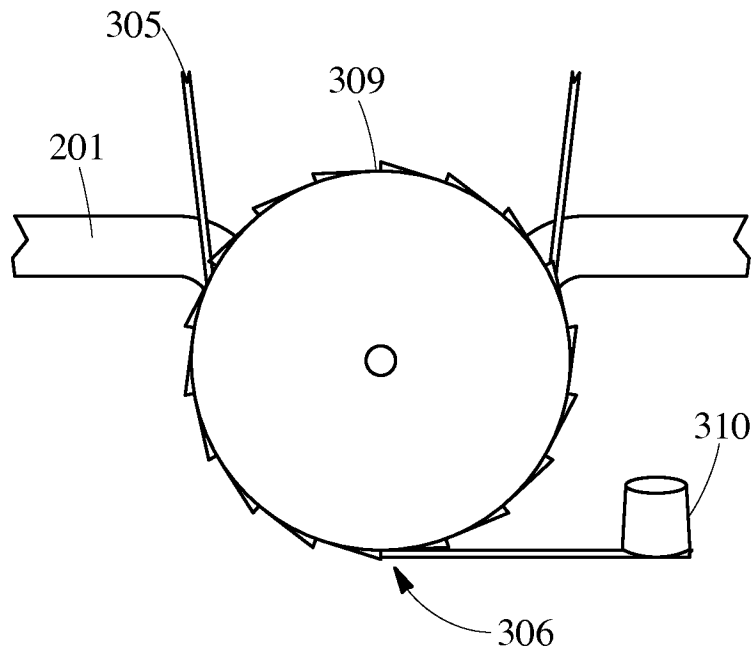

Fig. 3

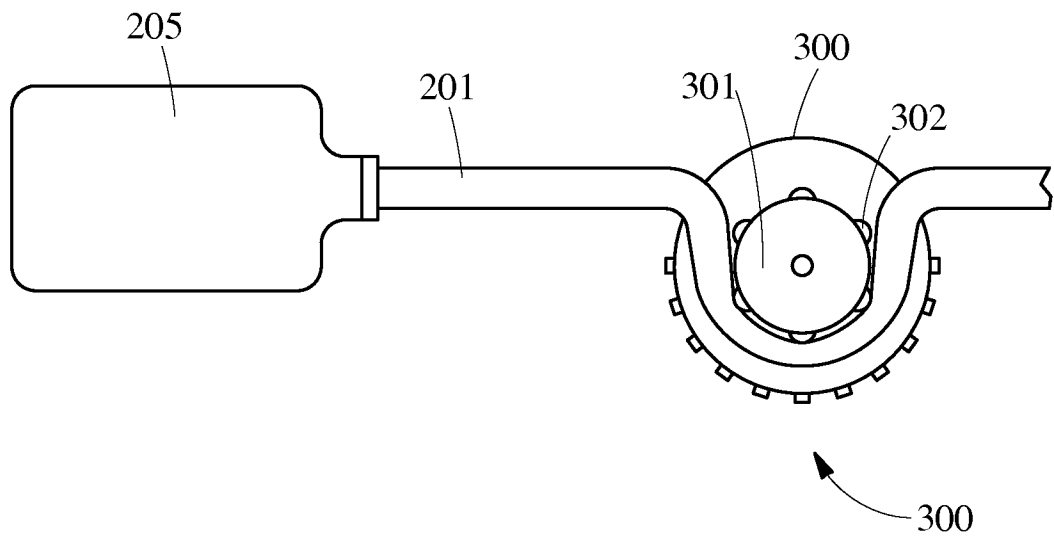

Fig. 4



3/3

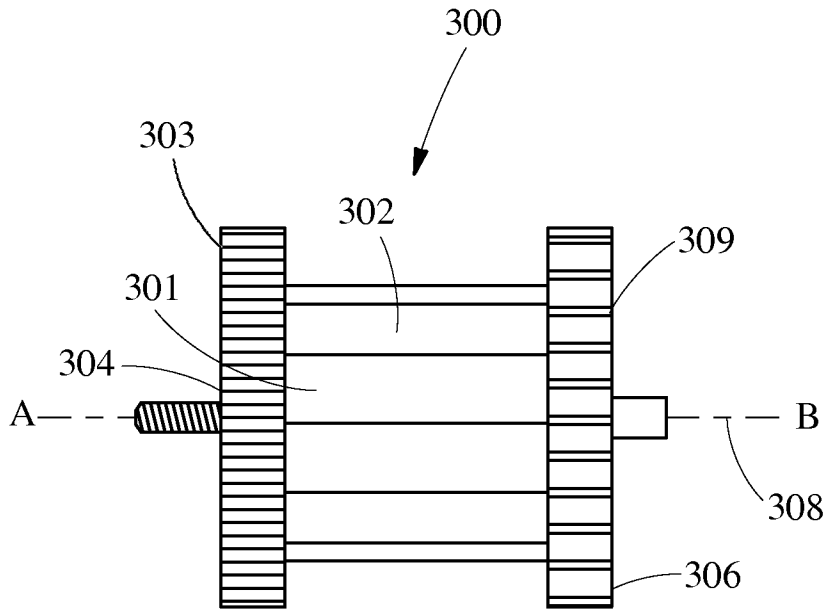

Fig. 5

# INTERNATIONAL SEARCH REPORT

International application No  
PCT/US2011/028482

**A. CLASSIFICATION OF SUBJECT MATTER**

INV. B26B19/40 B26B21/44  
ADD.

According to International Patent Classification (IPC) or to both national classification and IPC

**B. FIELDS SEARCHED**

Minimum documentation searched (classification system followed by classification symbols)  
B26B A46B

Documentation searched other than minimum documentation to the extent that such documents are included in the fields searched

Electronic data base consulted during the international search (name of data base and, where practical, search terms used)

EPO-Internal

**C. DOCUMENTS CONSIDERED TO BE RELEVANT**

Category*	Citation of document, with indication, where appropriate, of the relevant passages	Relevant to claim No.
A	US 2009/183371 A1 (MILETI ROBERT J [US] ET AL) 23 July 2009 (2009-07-23) the whole document -----	1-11
A	US 2006/289031 A1 (GREZ JOSEPH W [US] ET AL) 28 December 2006 (2006-12-28) the whole document -----	1-11
A	US 2005/144785 A1 (BRESSLER PETER [US] ET AL) 7 July 2005 (2005-07-07) the whole document -----	1-11
A	WO 2007/146974 A2 (GLASSMAN KAREN [US]; COPELAND STEPHAN [US]) 21 December 2007 (2007-12-21) the whole document -----	1-11

Further documents are listed in the continuation of Box C.

See patent family annex.

\* Special categories of cited documents :

- "A" document defining the general state of the art which is not considered to be of particular relevance
- "E" earlier document but published on or after the international filing date
- "L" document which may throw doubts on priority claim(s) or which is cited to establish the publication date of another citation or other special reason (as specified)
- "O" document referring to an oral disclosure, use, exhibition or other means
- "P" document published prior to the international filing date but later than the priority date claimed

- "T" later document published after the international filing date or priority date and not in conflict with the application but cited to understand the principle or theory underlying the invention
- "X" document of particular relevance; the claimed invention cannot be considered novel or cannot be considered to involve an inventive step when the document is taken alone
- "Y" document of particular relevance; the claimed invention cannot be considered to involve an inventive step when the document is combined with one or more other such documents, such combination being obvious to a person skilled in the art.
- "&" document member of the same patent family

Date of the actual completion of the international search

6 June 2011

Date of mailing of the international search report

15/06/2011

Name and mailing address of the ISA/

European Patent Office, P.B. 5818 Patentlaan 2  
NL - 2280 HV Rijswijk  
Tel. (+31-70) 340-2040,  
Fax: (+31-70) 340-3016

Authorized officer

Cardan, Cosmin

# INTERNATIONAL SEARCH REPORT

Information on patent family members

International application No PCT/US2011/028482
---

Patent document cited in search report	Publication date	Patent family member(s)	Publication date
US 2009183371 A1	23-07-2009	WO 2009094222 A1	30-07-2009
US 2006289031 A1	28-12-2006	NONE	
US 2005144785 A1	07-07-2005	AU 2004312048 A1	21-07-2005
		EP 1699606 A1	13-09-2006
		JP 2007516791 T	28-06-2007
		WO 2005065897 A1	21-07-2005
WO 2007146974 A2	21-12-2007	US 2008003048 A1	03-01-2008