



(12) **DEMANDE DE BREVET CANADIEN  
CANADIAN PATENT APPLICATION**

(13) **A1**

(86) Date de dépôt PCT/PCT Filing Date: 2019/06/03  
(87) Date publication PCT/PCT Publication Date: 2019/12/05  
(85) Entrée phase nationale/National Entry: 2020/11/25  
(86) N° demande PCT/PCT Application No.: GB 2019/051531  
(87) N° publication PCT/PCT Publication No.: 2019/229479  
(30) Priorité/Priority: 2018/06/01 (GB1809019.1)

(51) Cl.Int./Int.Cl. *B60L 53/53* (2019.01),  
*B60L 5/38* (2006.01), *B60L 5/39* (2006.01),  
*B60L 5/42* (2006.01), *B60L 50/53* (2019.01),  
*B60L 53/30* (2019.01), *B60L 9/00* (2019.01),  
*B60M 1/30* (2006.01), *B60M 1/36* (2006.01),  
*H02J 4/00* (2006.01), *H02J 7/00* (2006.01)  
(71) Demandeur/Applicant:  
VIVARAIL LTD, GB  
(72) Inventeur/Inventor:  
PETER, MASON, GB  
(74) Agent: CASSAN MACLEAN IP AGENCY INC.

(54) Titre : SYSTEME DE STOCKAGE ET DE CHARGE D'ENERGIE ELECTRIQUE D'UN VEHICULE DE TRANSPORT FERROVIAIRE

(54) Title: RAIL TRANSPORT VEHICLE ELECTRIC ENERGY STORAGE AND CHARGING SYSTEM

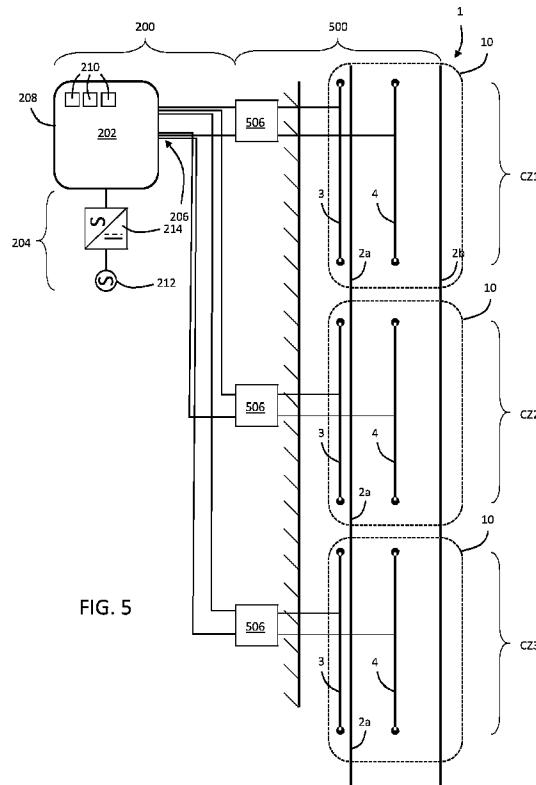

(57) **Abrégé/Abstract:**

A rail transport vehicle electric energy storage and charging system has an energy storage sub-system (200) and a charging system (400) having a charging rail (4) which only charges a vehicle (10) when the rail is covered. The invention also provides a battery-powered rail vehicle having a rail-contacting charging shoe.

(12) INTERNATIONAL APPLICATION PUBLISHED UNDER THE PATENT COOPERATION TREATY (PCT)

(19) World Intellectual Property Organization  
International Bureau



(10) International Publication Number  
**WO 2019/229479 A1**

(43) International Publication Date  
05 December 2019 (05.12.2019)

(51) International Patent Classification:

*B60L 53/53* (2019.01)      *B60L 5/42* (2006.01)  
*B60L 5/38* (2006.01)      *H02J 4/00* (2006.01)  
*B60L 9/00* (2019.01)      *H02J 7/00* (2006.01)  
*B60L 50/53* (2019.01)      *B60M 1/30* (2006.01)  
*B60L 53/30* (2019.01)      *B60M 1/36* (2006.01)  
*B60L 5/39* (2006.01)

(21) International Application Number:

PCT/GB2019/051531

(22) International Filing Date:

03 June 2019 (03.06.2019)

(25) Filing Language:

English

(26) Publication Language:

English

(30) Priority Data:

1809019.1      01 June 2018 (01.06.2018)      GB

(71) Applicant: **VIVARAIL LTD** [GB/GB]; Quinton Rail Technology Centre, Station Road, Long Marston, Stratford-Upon-Avon, Warwickshire CV37 8PL (GB).

(72) Inventor: **PETER, Mason**; Quinton Rail Technology Centre, Station Road, Long Marston, Stratford Upon Avon, Warwickshire, CV37 8PL (GB).

(74) Agent: **VAULT IP LIMITED**; 5th Floor, Cavendish House, 39 Waterloo Street, Birmingham, West Midlands B2 5PP (GB).

(81) Designated States (unless otherwise indicated, for every kind of national protection available): AE, AG, AL, AM, AO, AT, AU, AZ, BA, BB, BG, BH, BN, BR, BW, BY, BZ, CA, CH, CL, CN, CO, CR, CU, CZ, DE, DJ, DK, DM, DO, DZ, EC, EE, EG, ES, FI, GB, GD, GE, GH, GM, GT, HN, HR, HU, ID, IL, IN, IR, IS, JO, JP, KE, KG, KH, KN, KP, KR, KW, KZ, LA, LC, LK, LR, LS, LU, LY, MA, MD, ME, MG, MK, MN, MW, MX, MY, MZ, NA, NG, NI, NO, NZ, OM, PA, PE, PG, PH, PL, PT, QA, RO, RS, RU, RW, SA, SC, SD, SE, SG, SK, SL, SM, ST, SV, SY, TH, TJ, TM, TN, TR, TT, TZ, UA, UG, US, UZ, VC, VN, ZA, ZM, ZW.

(84) Designated States (unless otherwise indicated, for every kind of regional protection available): ARIPO (BW, GH, GM, KE, LR, LS, MW, MZ, NA, RW, SD, SL, ST, SZ, TZ, UG, ZM, ZW), Eurasian (AM, AZ, BY, KG, KZ, RU, TJ, TM), European (AL, AT, BE, BG, CH, CY, CZ, DE, DK, EE, ES, FI, FR, GB, GR, HR, HU, IE, IS, IT, LT, LU, LV, MC, MK, MT, NL, NO, PL, PT, RO, RS, SE, SI, SK, SM, TR), OAPI (BF, BJ, CF, CG, CI, CM, GA, GN, GQ, GW, KM, ML, MR, NE, SN, TD, TG).

(54) Title: Rail transport vehicle electric energy storage and charging system

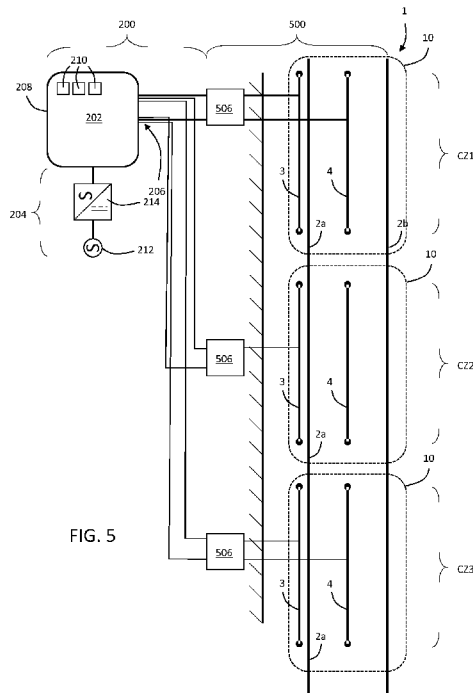

(57) Abstract: A rail transport vehicle electric energy storage and charging system has an energy storage sub-system (200) and a charging system (400) having a charging rail (4) which only charges a vehicle (10) when the rail is covered. The invention also provides a battery-powered rail vehicle having a rail-contacting charging shoe.



WO 2019/229479 A1

**WO 2019/229479 A1** 

---

**Published:**

- *with international search report (Art. 21(3))*
- *before the expiration of the time limit for amending the claims and to be republished in the event of receipt of amendments (Rule 48.2(h))*

### Rail transport vehicle electric energy storage and charging system

The present invention is concerned with a rail transport vehicle electric energy storage and charging system. More specifically, the present invention is concerned with an energy storage and charging system for charging the battery used to provide locomotive power on-board an electric rail passenger carriage.

Delays to the national electrification programme in the UK in particular have increased demand for autonomous (“self-propelled”) railway carriages, for example the Vivarail (TM) Class 230 DEMU. The Class 230 DEMU is a rebuild based on the bodysell and bogies of the former LUL D78 District Line trains.

10 The Class 230 is a self-propelled Electric Multiple Unit (EMU). By “self-propelled” we mean that the means of propulsion, or power source, is contained on board the unit. The unit is propelled by axle mounted traction motors that are controlled by a package of traction electronics. Those traction electronics rely on a 500 to 750V DC feed from a suitable power source. This can be one of, or a mixture of, diesel generators, battery packs or a fuel cell. The applicant’s previous patent application  
15 WO2017/025751 (incorporated herein by reference where permitted) provides details of the kind of modular system which can be implemented to allow the Class 230 to be powered by a variety of power sources, including a battery or array of batteries.

It will be noted that there is also a market for railway vehicles of this type outside the UK.

A problem with using batteries as the primary or sole locomotive power source on trains is the  
20 inherent limitation on range (assuming the line is not electrified). At current battery technology levels, the range of battery-powered trains would likely be limited to a distance less than the required travel time during the course of a day.

Therefore there is a need to replace the batteries during the course of the day’s running. The applicant’s previous patent application WO2017/025751 discloses an apparatus and method for  
25 replacing battery modules, but this requires some degree of expertise and manual intervention which may not be desirable at a railway station.

It is desirable to be able to recharge the batteries on-board the carriages. This is problematic in the UK because of limitations imposed by the ORR (the Office of Road and Rail – the Health and Safety regulatory body for railways) which state that at no time should exposed conductors providing the  
30 charging supply be accessible to passengers or the general public.

It is also problematic for the existing infrastructure. Existing electricity supplies are typically not capable of delivering the power levels required to charge a train battery in an adequate time period.

It is an aim of the present invention to overcome, or at least mitigate, the above problems.

According to a first aspect of the invention there is provided a rail electric power storage system for recharging battery powered rail units comprising:

a stationary battery;

a power input configured to charge the stationary battery at a first power level;

a power output configured to discharge the stationary battery at a second power level, higher than the first power level; and,

10 a charging apparatus for electrically connecting the power output to a battery powered train to charge a battery of the battery powered train.

This allows a standard power supply to be used at e.g. any available mains supply, typically 240V, 415V, 11kV, 33kV AC. The supply can continuously charge the battery for higher-power discharging to the train battery.

15 The power input may be connected to mains power and / or to an alternative power source such as PV panels or a wind turbine.

Preferably the power input is configured to continuously charge the stationary battery. By “continuously” we mean through the majority of the day- i.e. at least 20 hours out of 24. The battery may be charged during times when electricity is less expensive.

20 Preferably the power input is configured to charge the stationary battery at a low charge power, including being configured to trickle charge the stationary battery.

Preferably the stationary battery comprises a container storing at least one battery. Preferably there are provided a number of batteries provided in a battery group or array, in which the container is a shipping container. This allows for easy replacement of the battery or batteries.

25 According to a second aspect of the invention there is provided a rail transport vehicle charging system comprising:

a charging rail dimensioned to be fully coverable by a train carriage;

a power supply for charging an electric train battery, the power supply being configured to selectively supply a charging current to the charging rail; and,

a sensor apparatus configured to detect the position and / or movement of a train carriage over the charging rail;

in which the sensor is connected to the power supply such that the charging current is only supplied to the charging rail when the train carriage at least partially covers the charging rail.

- 5 Advantageously, this allows for simple charging (the train has a contact for the charging rail) and a high degree of safety, as unlike with known electrified lines, the line is only live when covered by the train.

Preferably the charging current is only supplied to the charging rail when the train carriage fully covers the charging rail.

- 10 Preferably the sensor is configured to detect a circuit being made with the charging rail, and to apply the charging current upon detection of the circuit being made.

A sensing electrical potential may be applied to the charging rail, in which the sensor is configured to detect a sensing current flowing as a result of the sensing electrical potential.

Preferably the sensing current is AC and the charging current is DC.

- 15 Preferably the sensor is configured to detect the presence of a train carriage over the charging rail.

The sensor may be an optical sensor. It may be an electromechanical sensor.

A combination of two sensors as discussed above may be provided for backup / redundancy.

Preferably the system comprises a plurality of discrete charging rails configured to simultaneously charge a plurality of train carriages.

- 20 Preferably each discrete charging rail comprises a respective sensor apparatus configured to detect the position and / or movement of a respective train carriage over the charging rail, and in which each sensor apparatus is connected to a power supply such that the charging current is only supplied to the respective charging rail when a respective train carriage at least partially covers the respective charging rail.

- 25 Preferably the power supply is common to the plurality of charging rails.

Preferably the charging rail is positioned between two running rails.

Preferably there is a further charging rail configured to make the charging circuit with the charging rail.

Preferably the further charging rail is connected to earth potential.

Preferably the further charging rail is positioned outside of the running rails. Preferably the system is configured per the London Underground (LU) four rail specification in terms of rail spacing. This allows LU vehicles to be easily adapted for use with the system.

5 Preferably there is provided a rail transport vehicle having an on-board battery arranged to be charged by the rail transport vehicle charging system, in which the rail transport vehicle comprises an electrical contact for contact with the charging rail. The contact may be a shoe.

10 The sensor apparatus may be on-board the rail transport vehicle. It may be configured to detect electrical connection between the electrical contact and the charging rail or configured to detect motion of the rail transport vehicle. The sensor apparatus may be configured to detect a driver input of the rail transport vehicle.

The invention also provides a rail transport vehicle electric energy storage and charging system comprising an electric energy storage according to the first aspect and a charging system according to the second aspect.

15 According to a third aspect of the invention there is provided an electric rail transport vehicle comprising an electric motor for propelling the vehicle, a battery arranged to power the electric motor and a rail contact electrode extending from the vehicle and configured to contact a rail, in which the rail contact electrode is connected to the battery to provide a charging current from the rail to the battery in use.

20 By "rail" we mean an elongate structure positioned below the vehicle, either directly below or below and to the side of the vehicle. The rail contact electrode or "shoe" may extend downwardly between the wheels on either side of the vehicle, or on one side of the wheels.

An example rail transport vehicle electric energy storage and charging system is described below with reference to the accompanying Figures, in which:

FIGURE 1 is a train comprising a number of carriages;

25 FIGURE 2 is a single powered train carriage;

FIGURE 3 shows a power module being inserted into a power module bay of the train carriage of Figure 2;

FIGURE 4 is a schematic of a first rail transport vehicle electric energy storage and charging system;

FIGURE 5 is a schematic of a second rail transport vehicle electric energy storage and charging system;

30 FIGURES 6a to 6c are schematics of a first charging interlock system in accordance with the invention;

FIGURES 7a and 7b are schematics of a second charging interlock system in accordance with the invention.

Figure 1 shows a four-carriage electric rail train 1, for running on a set of rails 2. The train is very similar to that described in WO2017/025751. The train 1 comprises a plurality of electric train  
5 carriages 10, each in the form of a self-propelled train carriage. The train 1 may therefore be referred to as a multiple unit. In this arrangement only two of the four carriages 10 are self-propelled (i.e. powered). However, it should be appreciated that there may be any suitable number of carriages, and any number of them may be self-powered. For example, a train 1 may comprise four carriages, only two of which may be motorized. In this embodiment, the front and rear carriages 10 are provided  
10 with a control cab from which the train 1 can be controlled.

The term “electric train carriage” should be understood to mean a train carriage which is arranged to be driven by an electric motor. The electric motor is supplied with power from a battery via traction electronics.

Figure 2 shows a single train carriage 10 which may be referred to as a multiple unit. The carriage 10  
15 comprises a main chassis or frame 12 and a carriage body 14 assembled as a monocoque. Mounted to the underneath of the main chassis 12 are front and rear bogies 16, 18, each having four wheels 20. Two electric motors 17, 19 are mounted to each bogie 16, 18 and are arranged to drive the wheels 20 of the respective bogie 16, 18. As will be explained in detail below, the electric motors are arranged to be powered by two on-board electric power modules 22 that are removably attached to the chassis  
20 12 and which contain batteries.

Each powered carriage 10 also comprises two power module bays 26, one for each power module 22. The power module bays 26 are attached to the underside of the chassis 12, or are defined by the underneath of the chassis 12, and are configured such that a power module 22 can be removably located and secured therein. With an electric power module 22 located and secured within a power  
25 module bay 26, the power module 22 is supported underneath the main chassis 12. An electric power module 22 can be quickly and easily replaced since it is removably located and secured within a power module bay 26. In this embodiment, and as will be described in detail below, an electric power module 22 can be inserted into a power module bay 26 from the side of the carriage 10 by moving the power module 22 in a horizontal direction that is transverse to the longitudinal axis of the carriage 10. A  
30 power module 22 can be inserted into and removed from a power module bay 26 without requiring access to the underside of the carriage, and without requiring the carriage to be lifted. This allows a power module 22 of a carriage 10 to be replaced in a remote location, without having to access the underneath of the carriage, which would require either lifting equipment or an inspection pit.

The train carriage 10 is configured such that it can be powered by a number of different types of compatible and interchangeable electric power modules 22, each type providing electric power utilising a different method. For the purposes of the present invention, the power modules are battery modules.

5 Figure 3 shows a power module 22 which can be located within a power module bay 26. The power module 22 shown in Figure 3 is a battery power module 22. The power module 22 is generally cuboidal and comprises a main structural support frame 28 that defines a cuboidal package. In this embodiment, the power module 22 has a front end 30 and a rear end 32 and is of a length that is greater than the width.

10 The power module 22 comprises an electrical connector for connecting external components (specifically the electric motors on the train) to the power module 22. There may also be an electrical connector for a safety earth cable. This may be a bolted connection.

The power module bay 26 comprises a securing mechanism having two parallel rods 82 driven by actuator handles 84 which can be manually actuated to secure and release the module 22 as described  
15 in WO2017/025751.

An energy storage and charging system 100 according to the present invention is shown in Figure 4. The system comprises an energy storage apparatus 200 and a charging apparatus 400.

#### Energy storage apparatus 200

The energy storage apparatus 200 comprises a battery array 202, a power input 204 and a power  
20 output 206.

The battery array 202 comprises a battery container 208 containing an array of individual batteries 210. The battery array is typically large in size and power capacity- and the container in this embodiment is a standard size shipping container. The array has a power capacity in the order of 5MWh.

25 The power input 204 comprises an AC source 212 (such as single- or three-phase mains power) connected to a power converter 214 comprising a rectifier. The power converter 214 is configured to constantly charge the cells 210 of the array 202, which may be described as “trickle” charging. This allows large amounts of energy to be stored in the battery array 202 to enable fast charging of train batteries via the charging system 400 described below via the power output 206.

30 The energy storage apparatus 200 may be located at a railway station and powered from the existing infrastructure.

#### First embodiment of a charging system 400

The charging system according to the present invention is based on a four-rail system. Generally, on a non-electrified railway there is the set of rails 2 as described above comprising a first rail 2a and a second rail 2b (Figure 4). The two running rails 2a, 2b are contacted by the wheels 20 of the carriages 10 during motion.

According to the charging system 400, a third rail 3 and a fourth rail 4 are provided. The third and fourth rails 3, 4 are parallel to the running rails 2a, 2b. The third rail 3 is adjacent to the first rail 2a but outside of the rails 2a, 2b. The fourth rail 4 is between the first and second rails 2a, 2b.

The third and fourth rails 3, 4 do not extend the length of the railway, and are positioned only in a charging zone CZ which may be e.g. adjacent a railway station at the end of a branch line. The length of the third and fourth rails 3, 4 (i.e. the size of the charging zone CZ) is predetermined, and selected to be less than the shortest train to be charged. In this manner, the third and fourth rails 3, 4 can be completely covered by a train 1 when in use.

The third and fourth rails 3, 4 are connected to an electrical power supply, in this instance the energy storage apparatus 200 via a power control module 406. The third rail 3 is permanently at earth potential, and the fourth rail 4 can be selectively connected to the power supply by the power control module 406. This offers a DC charging current for the onboard train batteries.

The carriage 10 comprises a first electrical rail contact 402 and a second electrical rail contact 404. These contacts are in the form of shoes which are well known in the field of electric train design. The first shoe 402 is configured to make contact with the third rail 3 when the carriage 10 is in the charging zone CZ. The second shoe 404 is configured to make contact with the fourth rail 4 when the carriage 10 is in the charging zone CZ. The shoes 402, 404 are connected to charging terminals on the battery modules 26 on the train. In this way, the batteries in the modules 26 can be charged from the storage apparatus 200.

#### Second embodiment of a charging system 500

Referring to Figure 5, a second embodiment of a charging system 500 according to the present invention is shown.

The charging system 500 comprises a third rail 3 and a fourth rail 4, but the rails are separated into three separate proximate but separate charging zones CZ1, CZ2, CZ3. One or more charging zones CZ1, CZ2, CZ3 can be covered by an individual carriage 10 of a train 1. Each charging zone has its own respective power control module 506 which can selectively power the charging rail in each of the

zones. Each third rail 3 is permanently at earth potential, and each fourth rail 4 can be selectively connected to the power supply by its respective power control module 506.

Each carriage 10 comprises a first electrical rail contact and a second electrical rail contact (not shown) in the form of shoes as shown in Figure 4.

- 5 Each charging zone CZ1 etc is individually interlocked. In other words, in order to allow the charging current to be delivered to the charging rail in the relevant zone, the relevant power control module 506 needs to be satisfied that a train carriage is in position.

This facilitates the charging system being provided to charge (in this example) up to three carriages 10. The system can also charge one or two carriages as required by the length of the train 1. For example, a single carriage 10 in zone CZ1 can be charged without the fourth rail 4 being live in either 10 of the other zones CZ2, CZ3.

#### Interlock

It will be understood that in either of the charging systems 400, 500 described above, it is not permitted for the fourth rail(s) 4 to become live (at least to a degree which would pose a danger) when 15 exposed- i.e. when a train is not present. The present invention comprises a series of interlocks to ensure that the fourth rail 4 is only made live when a train is present and set to the appropriate state to receive charging power, and thus manual access to the fourth rail 4 is prevented. The interlocks are as follows. It will be understood that each of these alone, or in combination could be employed with either embodiment as described above:

#### 20 *Electrical connection interlock – first embodiment*

Figures 6a to 6c show schematics of a first electrical interlock system 600 in various stages of operation.

The first electrical interlock system 600 has a rail side sub-system 602 and a vehicle side sub system 604.

- 25 The rail side sub-system 602 comprises two sections of fourth, or “live” rail 4 in two charging zones CZ1, CZ2 (refer to e.g. Figure 5 for further explanation of the charging zones). It will be noted that Figures 6a to 6c are schematic, and that the lengths of third rail 3 and fourth rail 4 will, in fact, be aligned per Figure 5.

The rail side sub-system is 602 is connected to the terminals of the energy storage apparatus 200 (or 30 other energy supply).

The live terminal of the energy storage apparatus 200 is connected via a first rail side power switch 606 to the section of fourth rail 4 in CZ1. The first rail side power switch 606 can alternately connect the CZ1 section of fourth rail 4 to the live terminal of the energy storage apparatus 200 or to earth potential E. The neutral terminal of the energy storage apparatus 200 is connected to the CZ1 section  
5 of third rail 3. The neutral terminal is connected to earth potential E.

A first series control / protect device 608 is provided downstream of the energy storage apparatus 200. It will be noted that the connection between the neutral terminal of the power supply 200 and earth is provided between the device 608 and the power supply 200.

The rail side sub-system 602 further comprises a signal generator circuit 610 connected to the first  
10 charging zone CZ1 portion of the fourth rail 4. The signal generator circuit 610 comprises an oscillator 612 that is configured to alternately produce a high frequency (HF) and low frequency (LF) AC pilot signal.

The live terminal of the energy storage apparatus 200 is also connected via a second rail side power switch 614 to the section of fourth rail 4 in CZ2. The second rail side power switch 614 can alternately  
15 connect the CZ2 section of fourth rail 4 to the live terminal of the energy storage apparatus 200 or to earth potential E. The neutral terminal of the energy storage apparatus 200 is connected to the CZ2 section of third rail 3. The neutral terminal is connected to earth potential E.

A second series control / protect device 616 is provided downstream of the energy storage apparatus 200. It will be noted that the connection between the neutral terminal of the power supply 200 and  
20 earth is provided between the device 616 and the power supply 200.

The rail side sub-system 602 further comprises a rail side detection circuit 618 connected to the second charging zone CZ2 portion of the fourth rail 4. The rail side detection circuit 618 comprises a low frequency (LF) sensor 620 and a high frequency (HF) sensor 622.

The rail side sub-system 602 comprises a rail side controller 621. The controller 621 is configured to  
25 receive data signals from the rail side detection circuit 618 (specifically the low frequency (LF) sensor 620 and the high frequency (HF) sensor 622) and to provide output control signals to the oscillator 612 and rail side power switches 606, 614 as will be described below.

The vehicle side sub-system 604 is provided on two carriages 10. Each carriage 10 comprises a train shoe 402 for contact with the third rail 3 and a train shoe 404 for contact with the fourth rail 4. Each  
30 train carriage 10 is configured to occupy a different charging zone CZ1, CZ2.

Each carriage 10 comprises a chargeable power module 22 having a series charge control device 623.

The third rail connection shoes 402 are connected to the power module 22.

The fourth rail connection shoes 404 are connected by a link capacitor 624. Each of the fourth rail connection shoes 404 are also connected to a vehicle side detection circuit 626 comprising a low frequency (LF) sensor 628 for each shoe. The fourth rail connection shoes 404 are also connected to a first and second vehicle side power switch 630, 632 respectively. The power switches are configured to alternately connect the shoes 404 to earth potential E, or the positive terminal of the power module 22.

The vehicle side sub-system 604 comprises a vehicle side controller 634. The controller 634 is configured to receive data signals from the vehicle side detection circuit 626 and to provide output control signals to the vehicle side power switches 630, 632 as will be described below.

The system 600 operates as follows.

Figure 6a shows the system in a condition where no railway vehicle is present. The fourth rail sections 4 in both charging zones CZ1, CZ2 are at earth potential due to the positions of the power switches 606, 614 connecting them to earth E. Therefore, the exposed rails are safe. The oscillator 612 produces a low frequency (LF) pilot signal in this condition.

Figure 6b shows the railway vehicle has moved into position. The vehicle's shoes 402, 404 contact each of the rails 3, 4. As contact is made, the low frequency signal is able to pass through the link capacitor 624 between the fourth rail sections 4 in the charging zones CZ1, CZ2 and can therefore be detected by the LF sensor 620 in the rail side detection circuit 618.

Upon detection, the rail side controller 621 switches the rail side power switches 606, 614 to connect the power source 200 to the fourth rail sections 4. This is shown in Figure 6c. The rail side controller 621 also instructs the oscillator 612 to switch from a low frequency (LF) to a high frequency (HF) pilot signal.

The high frequency (HF) signal is detected by the high frequency sensors 628 in the vehicle side detection circuit 626. The vehicle side controller 634, receiving this input then switches the vehicle side power switches 630, 632 such that the shoes 404 in contact with the fourth rail sections 4 are now in contact with the energy storage 22. There is now a charging circuit from the chargers 200 through to the vehicle batteries 22.

It will be noted that the rail side detection circuit 618 is configured to requires a pilot signal at all times (either high or low frequency) else the rail side controller 621 will switch the rail side power switches

back to earth potential E. In this way, movement of the vehicle causing a drop in contact between the shoes and rail will automatically cut the power to the live rail sections.

*Electrical connection interlock – second embodiment*

According to a second embodiment of the interlock, a “handshake” system is proposed.

- 5 Each power source (e.g. power control module 506) is provided with a digital electronic handshake module, which is configured to broadcast a low power “address” signal to the relevant section of connected fourth rail 4. The module is also configured to detect such low power address signals and to activate the charging current from the power control module 506 upon recognition of a predetermined response.
- 10 Each train carriage is also provided with a digital electronic handshake module, which is configured to detect low power address signals and to send a low power response signal to the relevant section of connected fourth rail 4 upon recognition of a predetermined address. The signals are passed through the contacts / shoes 404.

Each power control module 506 and contact 404 has a unique “address” signal.

- 15 Each charger address (which is unique to each of the charging modules) is “broadcast” to the relevant section of fourth rail 4 at all times by the charger digital electronic handshake module.

Once a shoe contacts the relevant section of rail 4, the train module detects the charger address. If the charger address matches the expected address, the electronic handshake module broadcasts the contact address back to the rail section.

- 20 If the digital electronic handshake module reads the correct contact / shoe address from the train, charging is initiated. Only once the train is in position with each carriage contacting the correct fourth rail section, are the sections made “live” and charging is initiated,

As the train arrives there would of course be a period when the chargers would be issuing their addresses and getting either no response or a false response. In these circumstances there is no charging current, and the fourth rail sections 4 are earthed.

25

Only when all of the chargers are “talking” to their correctly numbered contact / shoe does the system know the train is in the correct position and thus enables charging.

*Earth connection*

- The system checks that the earth connection made by the shoe 402 connecting the third rail 3 is made and proved to be satisfactory.
- 30

*Motion detection*

A train motion detector is provided which is configured to interrupt power to the fourth rail upon movement of the train (which would risk exposure of the fourth rail 4). Motion detection can take many forms, as will be appreciated by those in the art, but by way of example:

- 5       • A static sensor may be positioned proximate the railway line which is directed at the carriage 10. For example, a light-based (e.g. laser) motion sensor or a form of radio such as RFID, Bluetooth (TM) or Wi-Fi (TM).
- A sensor may be positioned on the train carriage which can communicate with the control module 406 to inform that the train is moving. The sensor may be connected to the train's
- 10       drive system, or may be e.g. an inertial device which can sense acceleration.

*Driver input detection*

A sensor may be provided to detect any action by the driver to select power or release the brakes disables the chargers and earths the fourth rail 4 and its shoes. The sensor would communication with the control module 406 to interrupt the charging current to the fourth rail should the train start to

15       move away.

*Earthed shoes*

When in motion all the shoes 402, 404 are held at earth potential eliminating the risk of electric shock to maintenance staff or passengers.

*Electrical connection interlock – third embodiment*

20       According to a third embodiment of the interlock, an alternative “handshake” system is proposed.

Figures 7a and 7b show schematics of the alternative electrical interlock system 700.

The electrical interlock system 700 has a rail side sub-system 702 and a vehicle side sub system 704.

The rail side sub-system 702 comprises a pair of power transfer rail sections 3a, 4a and a pair of interlock signal rail sections 3b, 4b. The sections 3a, 3b are in-line and the sections 4a, 4b are in-line

25       (though this is not essential). The section 4a, 4b is a live rail. The pairs 3a, 4a, 3b, 4b are contained within a single charging zone CZ. One charging zone is provided for each carriage of the train which needs to be charged (although only one is shown in Figures 7a and 7b).

The rail side sub-system is 702 is connected to the terminals of the energy storage apparatus 200 (or other energy supply).

The live terminal of the energy storage apparatus 200 is connected via a rail side power switch 706 to the section of fourth rail 4a in the charging zone CZ. The rail side power switch 706 can alternately connect the charging zone CZ section of fourth rail 4a to the live terminal of the energy storage apparatus 200 or to earth potential E. The neutral terminal of the energy storage apparatus 200 is connected to the charging zone section of third rail 3a. The neutral terminal is connected to earth potential E.

The rail side sub-system 702 further comprises a rail side signal generator and detection circuit 710 connected to the first charging zone CZ portion of the fourth rail 4b. The rail side signal generator and detection circuit 710 comprises a signal source in the form of an oscillator 711 that is configured to produce a pilot signal. The rail side signal generator and detection circuit 710 comprises a sensor 720.

The rail side sub-system 702 comprises a rail side controller 721. The controller 721 is configured to receive data signals from the rail side signal generator and detection circuit 710 (specifically the sensor 720) and to provide output control signals to the oscillator (not shown) and a PLC 707 which controls the rail side power switch 706, as will be described below.

The vehicle side sub-system 704 is provided on each carriage 10. Each carriage 10 comprises a first train shoe 402a for contact with the third rail section 3a, a second train shoe 402b for contact with the third rail section 3b, a first train shoe 404a for contact with the fourth rail section 4a and a second train shoe 404b for contact with the fourth rail section 4b. Each train carriage 10 is configured to occupy a different charging zone CZ.

Each carriage 10 comprises a chargeable power module 22 having a series charge control device (not shown). The third rail connection shoes 402a, 402b are connected to the power module 22.

The vehicle side sub-system 704 further comprises a vehicle side signal generator and detection circuit 730 comprising a signal source in the form of an oscillator 705, the circuit being connected to the first charging zone CZ portion of the fourth rail 4b. The vehicle side signal generator and detection circuit 730 comprises a sensor 732.

Operation of the electrical interlock system 700 will now be described.

The charging rails 4a, 4b are held at earth potential until the interlock is cleared in order to ensure that if a carriage 10 is not in the charging zone CZ, the charging rails 4a, 4b are not "live".

Upon arrival of the train at a charging station, the vehicle side signal generator and detection circuit 730 transmits a signal indicating that the carriage is present and that the train is active (for example the driver's key is installed and/or the brakes are off). This signal is generally produced at all times-

not only when the train arrives at a charging station. The signal is received by the rail side signal generator and detection circuit 710. The sensor 720 detects that the carriage is in position and the fact that the train is still active.

5 Upon removal of the driver's key and/or application of the brakes, a signal of a different frequency is transmitted by the vehicle side signal generator and detection circuit 730 to the rail side signal generator and detection circuit 710. In response, the rail side signal generator and detection circuit 710 transmits a signal at a further frequency.

10 The 'handshake' of this embodiment of the invention includes the exchange of signals at specific frequencies between the vehicle side signal generator and detection circuit 730 and the rail side signal generator and detection circuit 710.

Upon completion of the 'handshake', a signal is transmitted from the rail side signal generator and detection circuit 710 to the vehicle side signal generator and detection circuit 730 via the PLC 707 to prepare the vehicle for charge. A signal is transmitted to the rail side power switch 706 from the PLC 707 to commence charging.

15 The 'handshake' continues throughout charging. Charging is continued as long as the 'handshake' is successfully completed and the driver's key remains out and/or the brakes are applied.

Upon re-insertion of the driver's key, a change in the frequency of the transmitted signal is received by the rail side signal generator and detection circuit 730, the rail side power switch 706 is opened to disconnect the supply of power.

20 Although in the embodiment above, the carriage 10 is described as having two pairs of shoes 402a, 402b, 404a, 404b, it will be understood that the carriage may have a single pair of shoes.

The present embodiment is beneficial because existing railway carriages tend to have a "driver's key" signal sent throughout the entire train which can be utilised to provide the signal. Therefore no further wiring between carriages is required.

25 Although in the embodiment above, the rail side sub-system 702 is described as comprising two sections of fourth, or "live" rail 4a, 4b and two sections of third rail 3a, 3b in a single charging zone CZ, it will be understood that the rail side sub-system 702 may have a single section of fourth, or "live" rail 4 and a single section of third rail 3 in a single charging zone CZ. In this embodiment the interlock signal is overlaid on the power signal during charging.

It will be noted that according to a further embodiment, a wheel sensor may be used in series with the interlock detection apparatus such that movement of the carriage out of position will also cease the charging operation. The sensor may be e.g. optical or magnetic.

Variations fall within the scope of the present invention.

- 5 The charging system 400 is configured to work with the energy storage apparatus 200, although it will be noted that the systems can be used independently.

For example, the energy storage system 200 may be used with any other type of charging system, for example requiring a lead to be manually plugged into the train battery unit. The charging system 400 may be used with other power sources, such as electrical generators or mains power.

- 10 The battery array 200 may be charged by other means than the mains grid. For example, renewable energy generators may be installed on the container 208 and / or adjacent station to charge the array either alone or in combination with mains power. For example, solar panels may be installed, or wind turbines.

- 15 Instead of a third rail, the first and / or second rails may be at earth potential, and complete the charging circuit, although this is not preferred. As such, it would be possible to use the wheels, brush gear and running rail(s) as the earth path for charging, although this is not preferred.

The system may be configured to provide AC to the railway vehicle instead of DC.

## Claims

1. A rail electric power storage system for charging battery powered rail units comprising:
  - a stationary battery;
  - a power input configured to charge the stationary battery at a first power level;
- 5 a power output configured to discharge the stationary battery at a second power level, higher than the first power level; and,
  - a charging apparatus for electrically connecting the power output to a battery powered train to charge a battery of the battery powered train.
2. A rail electric power storage system according to claim 1, in which the power input is
 10 connected to mains power.
3. A rail electric power storage system according to claim 1 or 2, in which the power input is configured to continuously charge the stationary battery.
4. A rail electric power storage system according to any preceding claim, in which the power input is configured to trickle charge or charge at relatively low power the stationary battery.
- 15 5. A rail electric power storage system according to any preceding claim, in which the stationary battery comprises a container storing at least one battery cell, in which the container is a shipping container.
6. A rail transport vehicle charging system comprising:
  - a charging rail dimensioned to be fully coverable by a train carriage;
- 20 a power supply for charging an electric train battery, the power supply being configured to selectively supply a charging current to the charging rail; and,
  - a sensor apparatus configured to detect the position and / or movement of a train carriage over the charging rail;
  - in which the sensor is connected to the power supply such that the charging current is only
 25 supplied to the charging rail when the train carriage at least partially covers the charging rail.
7. A rail transport vehicle charging system according to claim 6, in which the charging current is only supplied to the charging rail when the train carriage fully covers the charging rail.

8. A rail transport vehicle charging system according to claim 6 or 7, in which the sensor is configured to detect a circuit being made with the charging rail, and to apply the charging current upon detection of the circuit being made.
9. A rail transport vehicle charging system according to claim 8, configured to apply a sensing electrical potential to the charging rail, in which the sensor is configured to detect a sensing current flowing as a result of the sensing electrical potential.
10. A rail transport vehicle charging system according to claim 9, in which the sensing current is AC and the charging current is DC.
11. A rail transport vehicle charging system according to any of claims 6 to 10, in which the sensor is configured to detect the presence of a train carriage over the charging rail.
12. A rail transport vehicle charging system according to claim 11, in which the sensor is an electromagnetic, e.g. optical or radio frequency sensor.
13. A rail transport vehicle charging system according to any of claims 6 to 12, comprising a plurality of discrete charging rails configured to simultaneously charge a plurality of train carriages.
14. A rail transport vehicle charging system according to claim 13, in which each discrete charging rail comprises a respective sensor apparatus configured to detect the position and / or movement of a respective train carriage over the charging rail, and in which each sensor apparatus is connected to a power supply such that the charging current is only supplied to the respective charging rail when a respective train carriage at least partially covers the respective charging rail.
15. A rail transport vehicle charging system according to claim 14, in which the power supply is common to the plurality of charging rails.
16. A rail transport vehicle charging system according to any of claims 6 to 15, in which the charging rail is positioned between two running rails.
17. A rail transport vehicle charging system according to any of claims 6 to 16, comprising a further charging rail configured to make the charging circuit with the charging rail.
18. A rail transport vehicle charging system according to claim 17, in which the further charging rail is connected to earth potential.
19. A rail transport vehicle charging system according to claim 18, in which the further charging rail is positioned outside of the running rails.

20. A rail transport vehicle charging system according to any of claims 6 to 19, comprising a rail transport vehicle having an on-board battery arranged to be charged by the rail transport vehicle charging system, in which the rail transport vehicle comprises an electrical contact for contact with the charging rail.
- 5 21. A rail transport vehicle charging system according to claim 20, in which the sensor apparatus is on-board the rail transport vehicle.
22. A rail transport vehicle charging system according to claim 21, in which the sensor apparatus is configured to detect electrical connection between the electrical contact and the charging rail.
23. A rail transport vehicle charging system according to claim 22, in which the sensor apparatus  
10 is configured to detect motion of the rail transport vehicle.
24. A rail transport vehicle charging system according to claim 23, in which the sensor apparatus is configured to detect a driver input of the rail transport vehicle.
25. A rail transport vehicle electric energy storage and charging system comprising an electric energy storage according to any of claims 1 to 5 and a charging system according to any of claims 6 to  
15 24.
26. An electric rail transport vehicle comprising:  
an electric motor for propelling the vehicle;  
a battery arranged to power the electric motor; and,  
a rail contact electrode extending from the vehicle and configured to contact a rail, in which  
20 the rail contact electrode is connected to the battery to provide a charging current from the rail to the battery in use.
27. An electric rail transport vehicle according to claim 24, comprising two sets of wheels, the sets of wheels spaced apart in a direction normal to a direction of travel of the vehicle, in which the rail contact member extends between the two sets of wheels.
- 25 28. An electric rail transport vehicle according to claim 24, comprising two sets of wheels, the sets of wheels spaced apart in a direction normal to a direction of travel of the vehicle, in which the rail contact member extends on one side of the two sets of wheels.
29. An electric rail transport vehicle according to any of claims 26 to 28, and a rail transport vehicle charging system according to any of claims 6 to 19 in which the rail contact member is in contact with  
30 the charging rail.

30. A rail transport vehicle and charging system comprising an electric energy storage according to any of claims 1 to 5 and an electric rail transport vehicle according to claim 29.

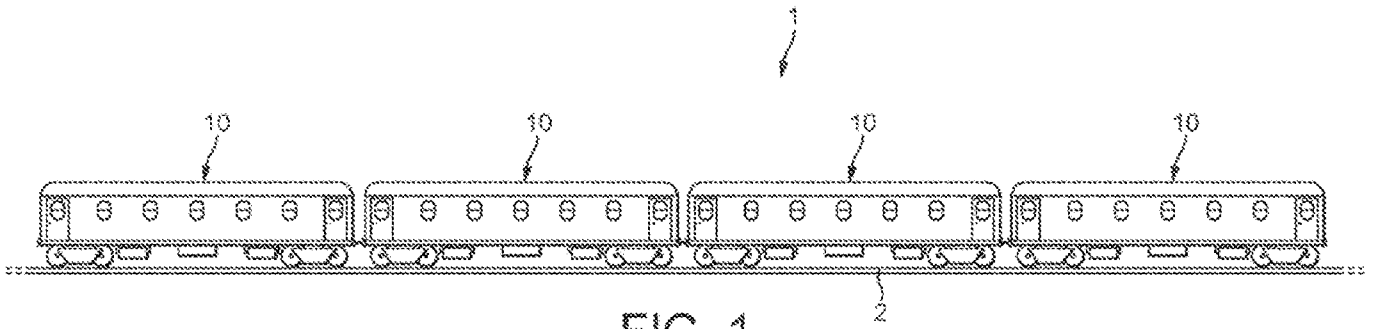

FIG. 1

2/9

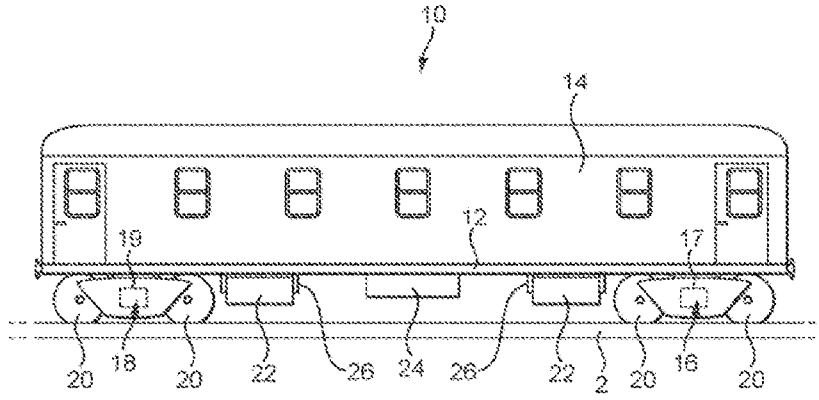

FIG. 2

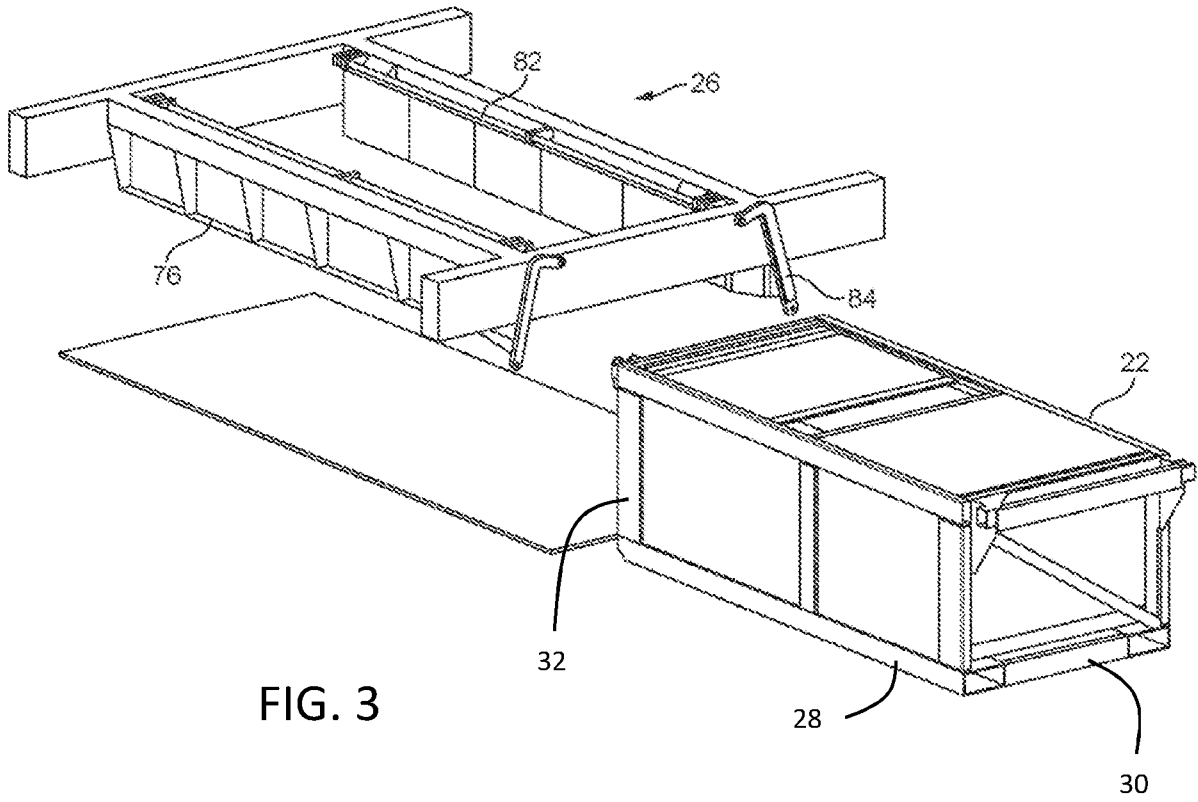

FIG. 3

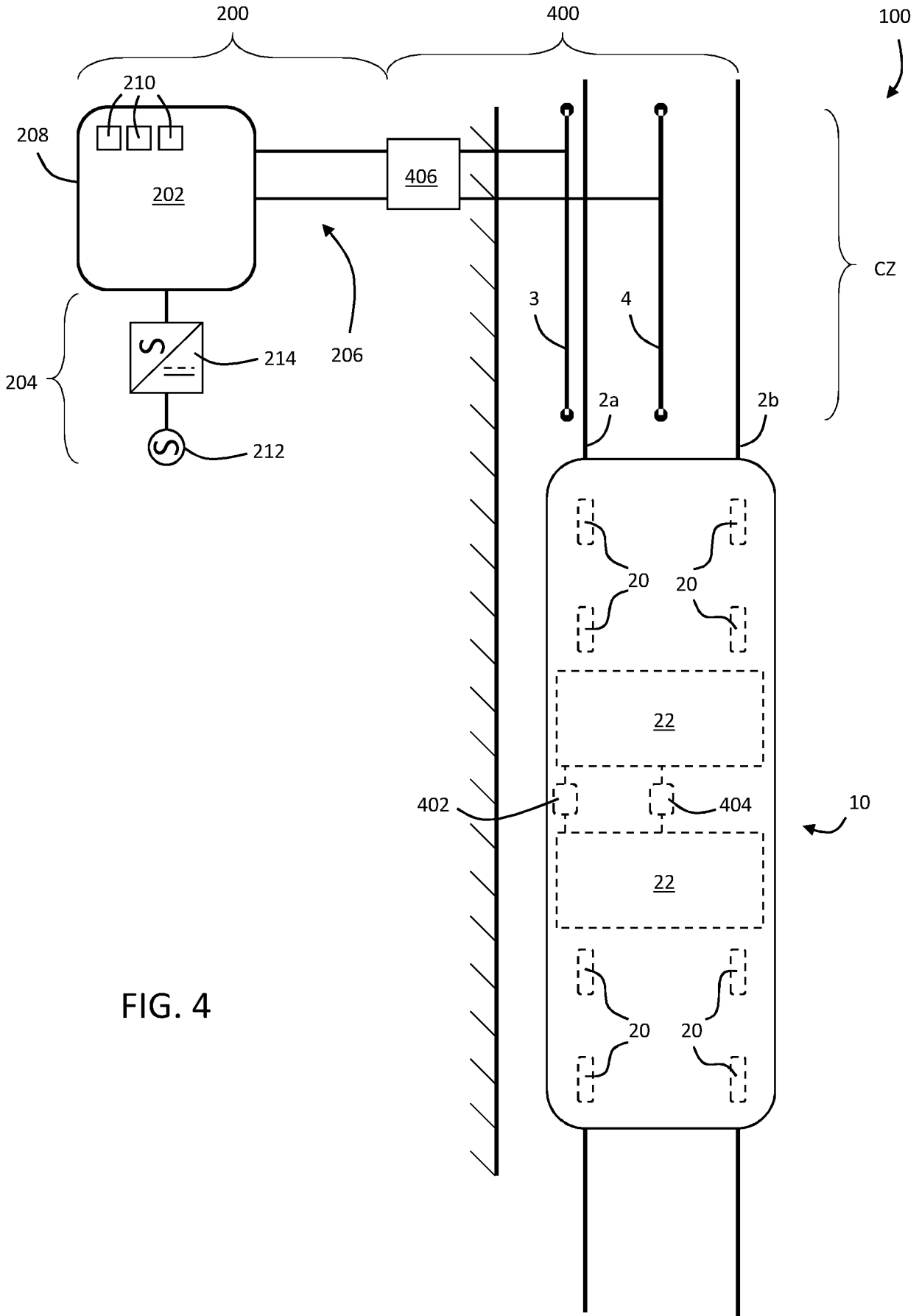

FIG. 4

4/9

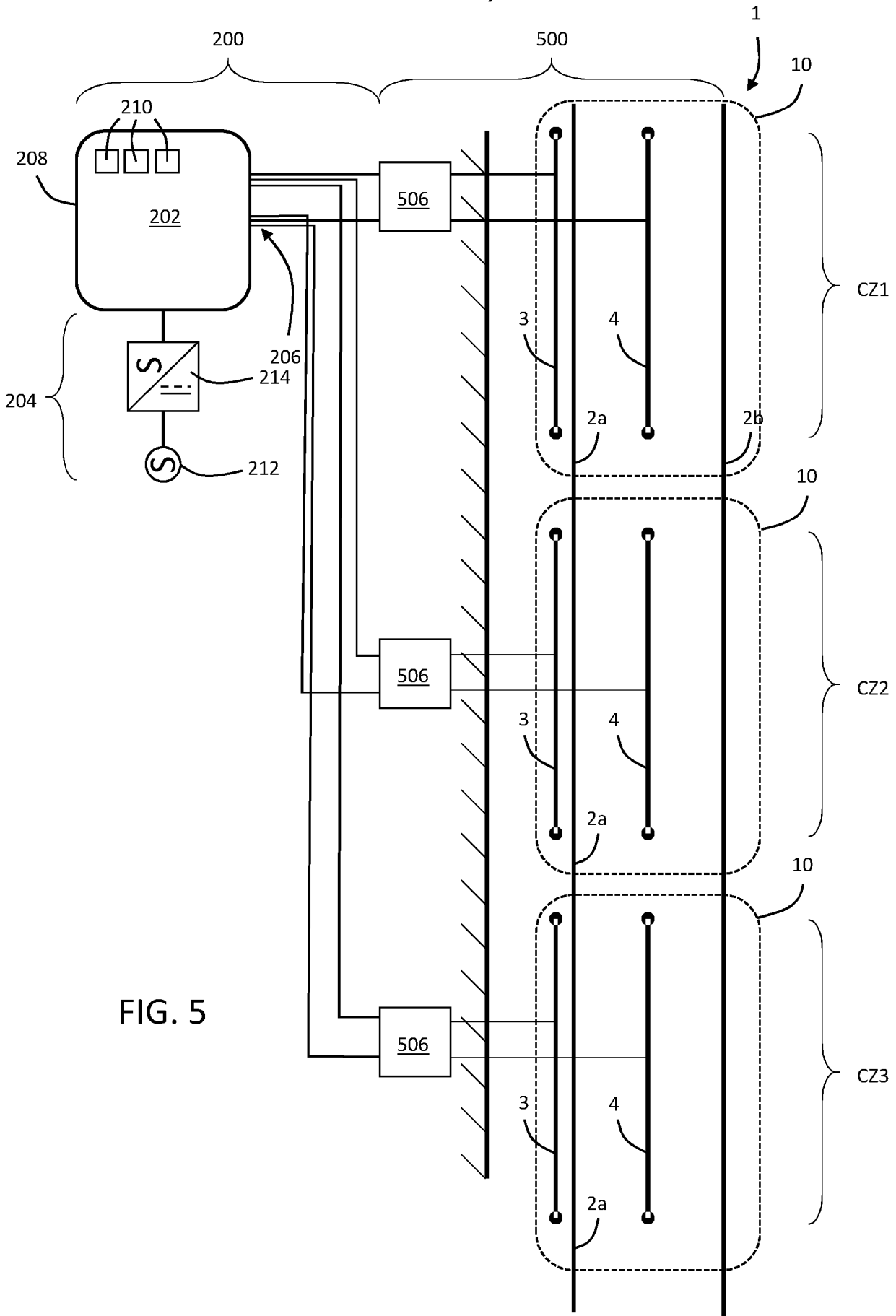

FIG. 5

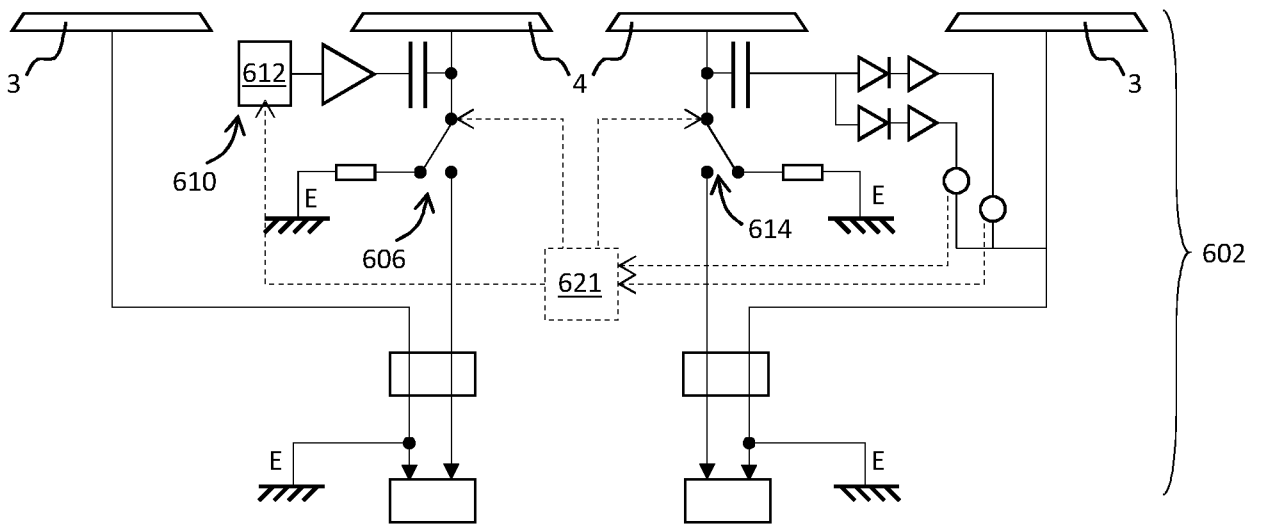

FIG. 6a

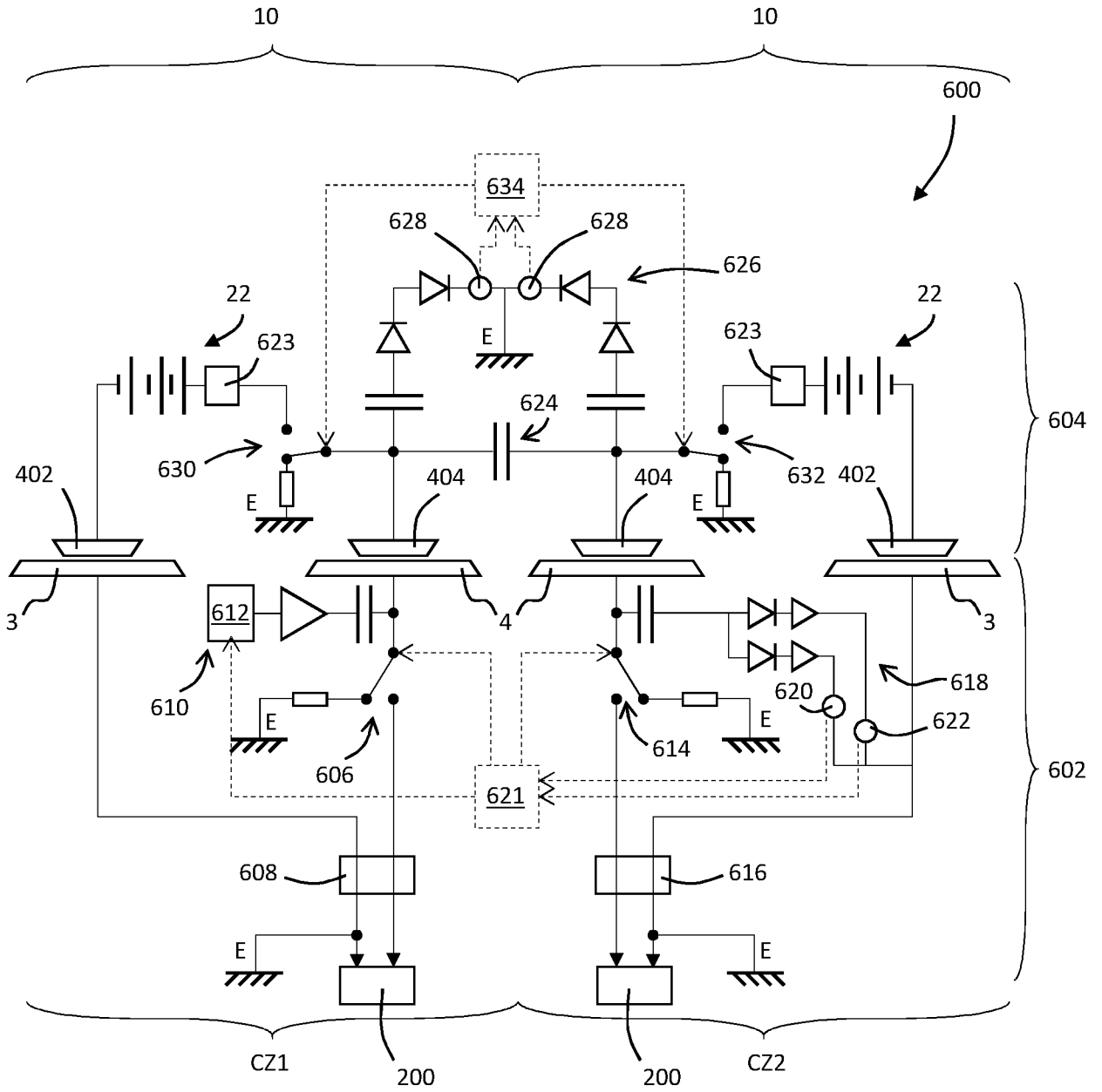

FIG. 6b

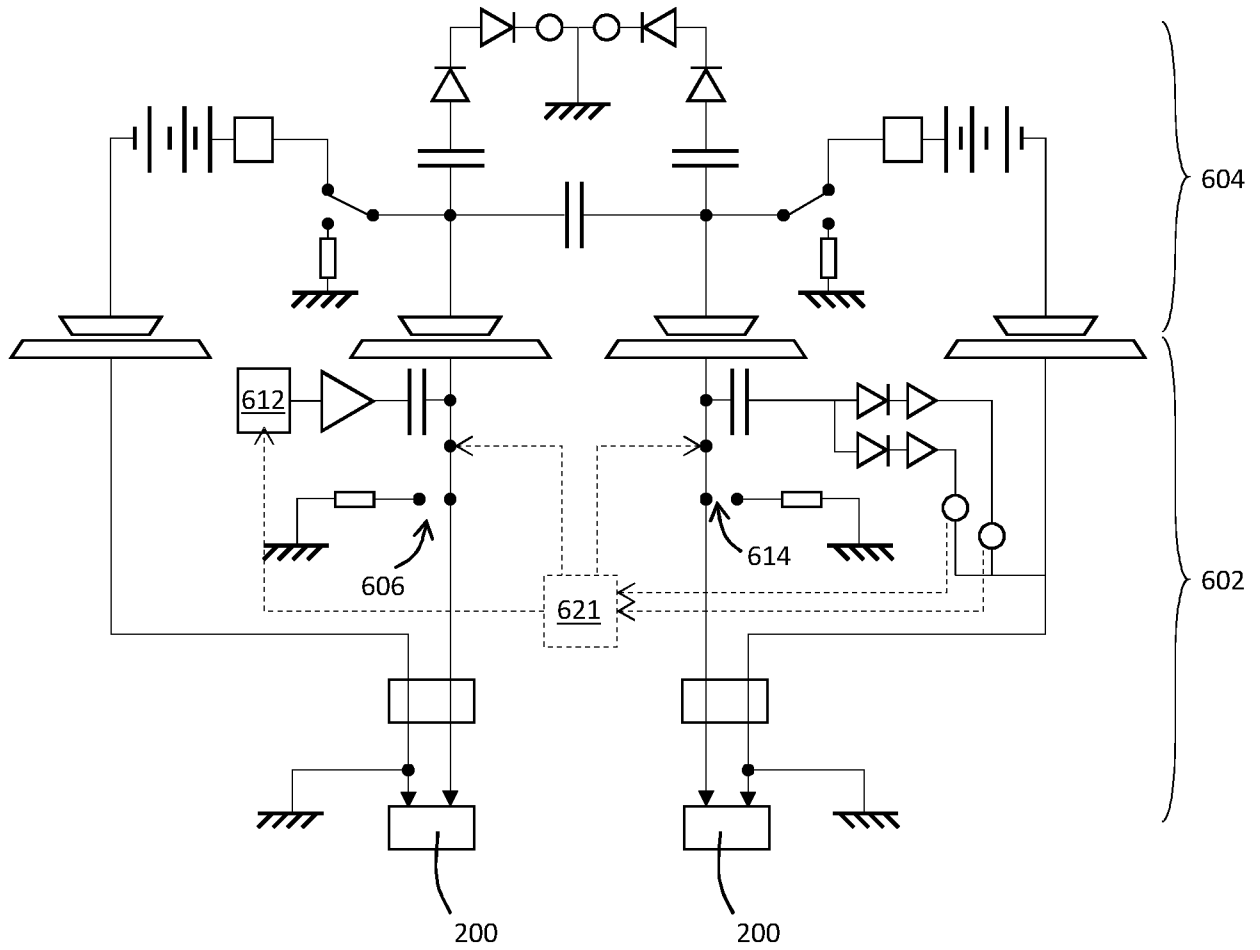

FIG. 6c

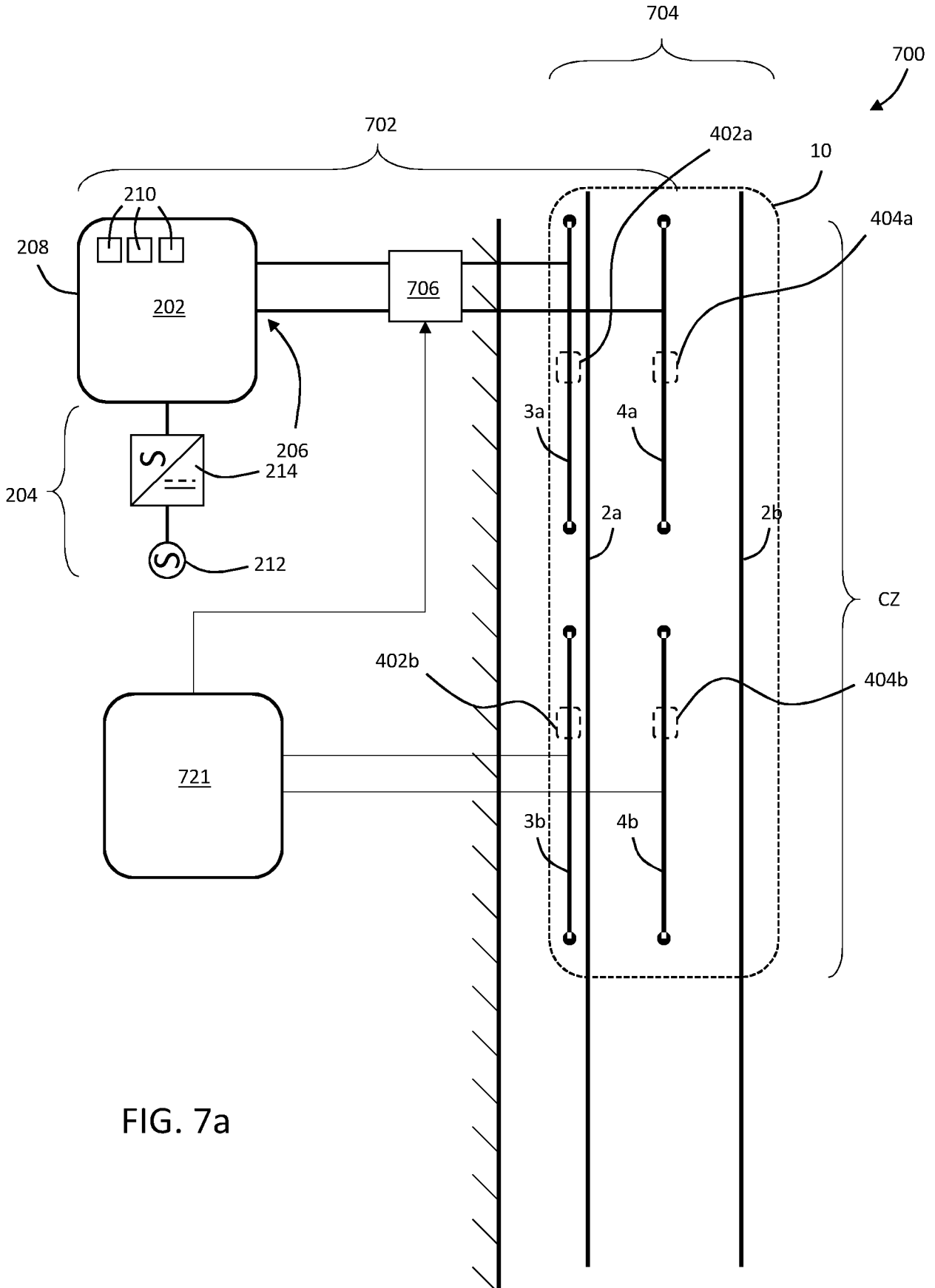
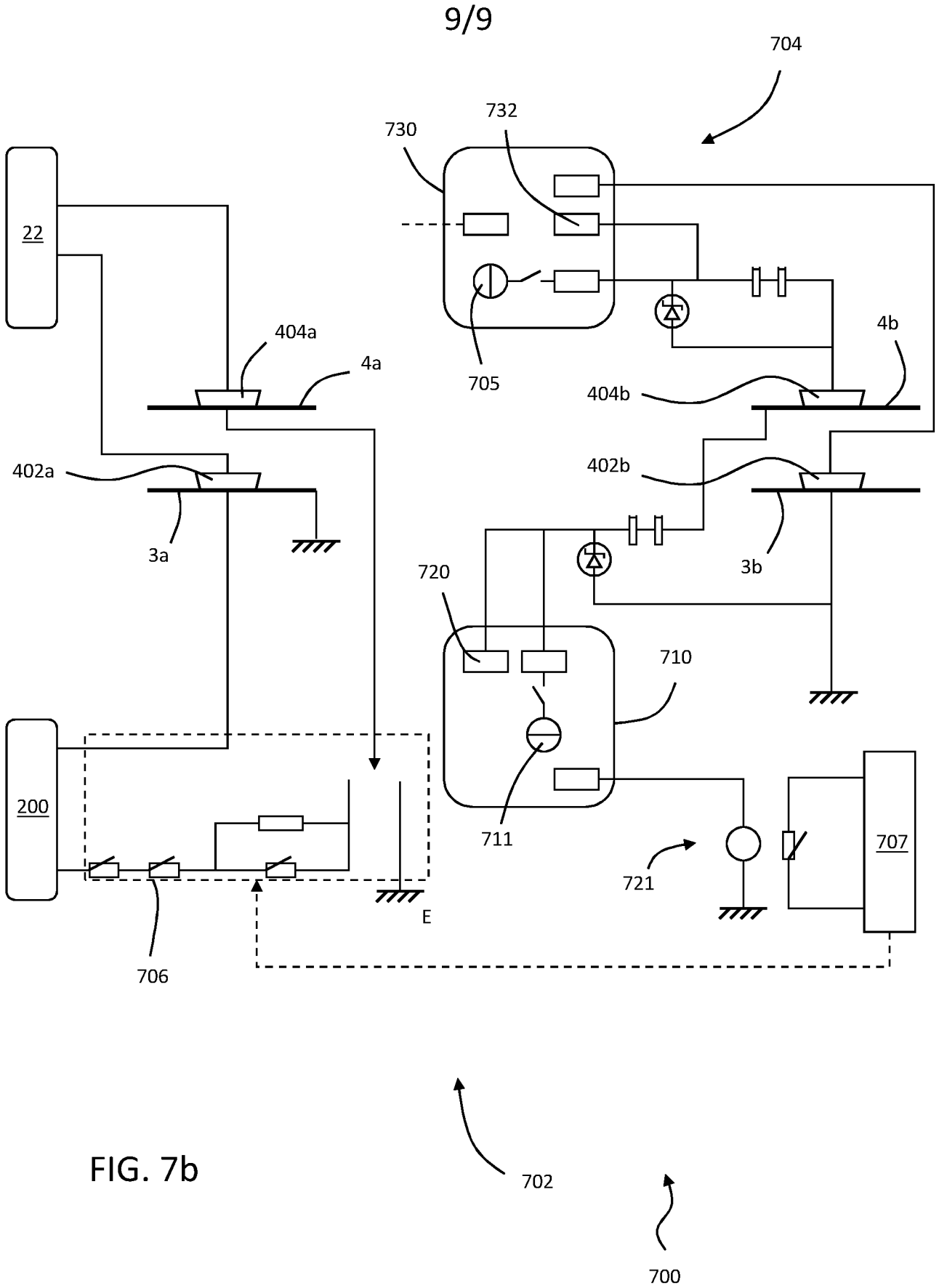

FIG. 7a



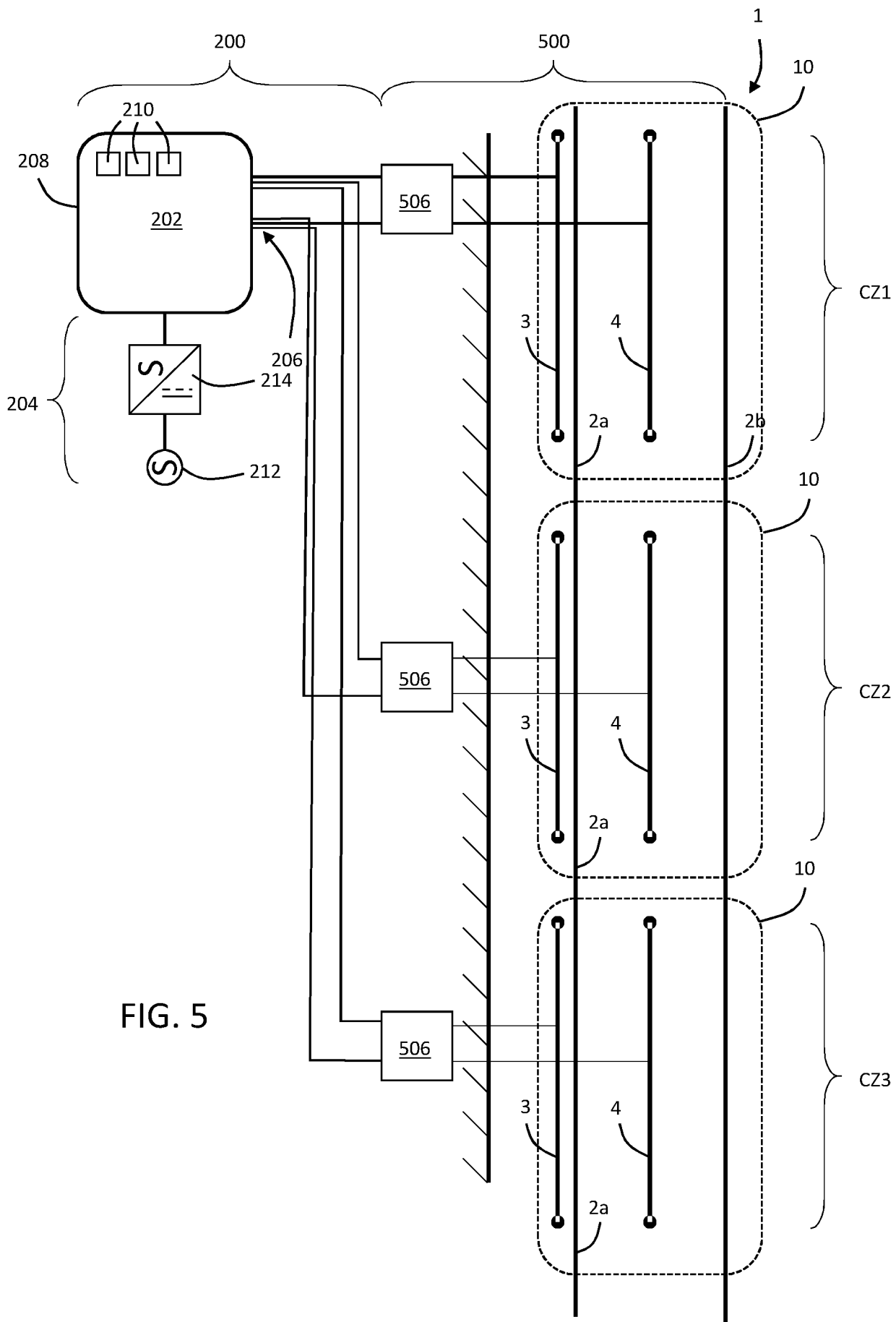

FIG. 5