

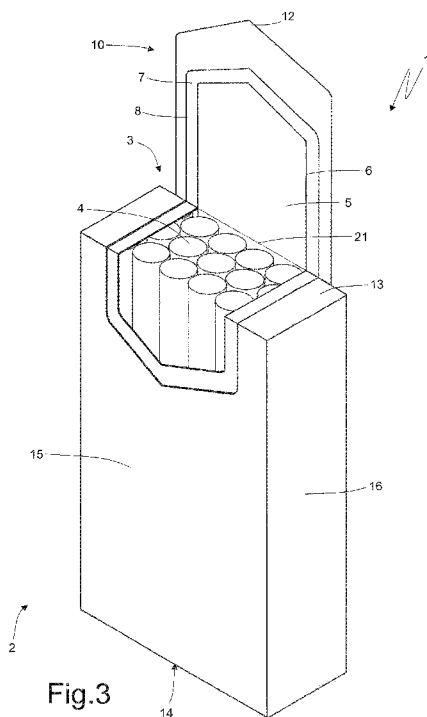

- (51) International Patent Classification:  
*B65D 85/10* (2006.01) *B65D 5/54* (2006.01)
- (21) International Application Number: PCT/IB2014/061597
- (22) International Filing Date: 21 May 2014 (21.05.2014)
- (25) Filing Language: Italian
- (26) Publication Language: English
- (30) Priority Data:  
BO2013A000235 21 May 2013 (21.05.2013) IT
- (71) Applicant: **G.D SOCIETA' PER AZIONI** [IT/IT]; Via Battindarno, 91, Bologna (IT).
- (72) Inventors: **TACCHI, Alver**; Via Vittoria, 2, I-40100 Bologna (IT). **D'ALFONSO, Lorena**; Via Pietrara, 52, I-45020 Lettomappello (IT). **POLLONI, Roberto**; Via Lega, 91, I-47015 Modigliana (IT). **NEGRINI, Stefano**; Via Longarola, 21, I-40012 Calderara di Reno (IT).
- (74) Agents: **MACCAGNAN, Matteo** et al.; Studio Torta S.p.A., Via Viotti, 9, I-10121 Torino (IT).
- (81) Designated States (*unless otherwise indicated, for every kind of national protection available*): AE, AG, AL, AM, AO, AT, AU, AZ, BA, BB, BG, BH, BN, BR, BW, BY, BZ, CA, CH, CL, CN, CO, CR, CU, CZ, DE, DK, DM, DO, DZ, EC, EE, EG, ES, FI, GB, GD, GE, GH, GM, GT, HN, HR, HU, ID, IL, IN, IR, IS, JP, KE, KG, KN, KP, KR, KZ, LA, LC, LK, LR, LS, LT, LU, LY, MA, MD, ME, MG, MK, MN, MW, MX, MY, MZ, NA, NG, NI, NO, NZ, OM, PA, PE, PG, PH, PL, PT, QA, RO, RS, RU, RW, SA, SC, SD, SE, SG, SK, SL, SM, ST, SV, SY, TH, TJ, TM, TN, TR, TT, TZ, UA, UG, US, UZ, VC, VN, ZA, ZM, ZW.
- (84) Designated States (*unless otherwise indicated, for every kind of regional protection available*): ARIPO (BW, GH, GM, KE, LR, LS, MW, MZ, NA, RW, SD, SL, SZ, TZ, UG, ZM, ZW), Eurasian (AM, AZ, BY, KG, KZ, RU, TJ, TM), European (AL, AT, BE, BG, CH, CY, CZ, DE, DK, EE, ES, FI, FR, GB, GR, HR, HU, IE, IS, IT, LT, LU, LV, MC, MK, MT, NL, NO, PL, PT, RO, RS, SE, SI, SK, SM,

[Continued on next page]

(54) Title: PACKET WITH A RECLOSABLE SEALING PANEL



(57) Abstract: A packet (1) having: a group (4) of articles; a sealed package (3) enclosing the group (4) of articles and having a first cover flap (5), which is defined by a first cut (6) through the sealed package (3) and is movable to allow access to the group (4) of articles; a rigid container (2) enclosing the sealed package (3) and having a second cover flap (7), which is defined by a second cut (8) through the container (2), is superimposed on the first cover flap (5) of the sealed package (3), and is movable to allow access to the sealed package (3); and a reclosable adhesive panel (10), which is coated on the inside with re-stick adhesive (11), and has a grip tab (12) with no re-stick adhesive (11) and located at an edge of the adhesive panel (10);

TR), OAPI (BF, BJ, CF, CG, CI, CM, GA, GN, GQ, GW, KM, ML, MR, NE, SN, TD, TG). **Published:**

— with international search report (Art. 21(3))

## PACKET WITH A RECLOSABLE SEALING PANEL

TECHNICAL FIELD

The present invention relates to a packet with a  
5 reclosable sealing panel.

In the following description, reference is made,  
for the sake of simplicity, to a rigid packet of  
cigarettes purely by way of a non-limiting example.

BACKGROUND ART

10 A rigid, hinged-lid packet of cigarettes normally  
comprises an inner package enclosing a group of  
cigarettes; and a rigid outer container housing the  
inner package.

To better preserve the organoleptic characteristics  
15 of the cigarette tobacco, a sealed inner package has  
recently been proposed, which is formed by folding and  
heat-sealing a sheet of impermeable packing material. To  
permit withdrawal of the cigarettes, the sealed inner  
package has a cover flap normally covered by an 'open-  
20 close' type sealing panel. More specifically, the  
sealing panel is coated with non-dry, re-stick adhesive  
enabling it to be fixed repeatedly in a position sealing  
the inner package.

The rigid outer container normally comprises a  
25 hinged lid, which must be opened first for access to the  
sealing panel underneath, which must then be pulled up

to withdraw a cigarette from the group inside the sealed inner package. In other words, withdrawing a cigarette from the group inside the sealed inner package involves two separate, successive opening operations (opening the rigid outer container lid, and opening the sealing panel on the sealed inner package) which must also be repeated in reverse order to close the packet of cigarettes after the cigarette is withdrawn.

Having to perform two separate, successive opening/closing operations obviously makes the packet of cigarettes awkward to use.

Patent Application US2012111746A1 describes a packet of cigarettes comprising a sealed package, which encloses a group of cigarettes and has a first cover flap defined by a cut through the sealed package and which is movable for access to the group of cigarettes; and a rigid container, which encloses the sealed package and has a second cover flap superimposed on and glued to the first cover flap of the sealed package, and which is movable with the first cover flap to allow access to the group of cigarettes. The packet of cigarettes described in Patent Application US2012111746A1, however, has several drawbacks, by requiring a fairly large amount of packing material, as well as unconventional folding of the blank from which the rigid container is formed, on account of the second cover flap forming part of the

rigid container.

#### DESCRIPTION OF THE INVENTION

It is an object of the present invention to provide a packet with a reclosable sealing panel, designed to eliminate the above drawbacks, i.e. which can be opened/closed in one operation, and which at the same time is cheap and easy to produce.

According to the present invention, there is provided a packet with a reclosable sealing panel, as claimed in the accompanying Claims.

#### BRIEF DESCRIPTION OF THE DRAWINGS

A number of non-limiting embodiments of the present invention will be described by way of example with reference to the attached drawings, in which:

Figure 1 shows a front view in perspective of a packet of cigarettes in accordance with the present invention in a closed configuration;

Figure 2 shows a rear view in perspective of the Figure 1 packet of cigarettes in a closed configuration;

Figure 3 shows a front view in perspective of the Figure 1 packet of cigarettes in an open configuration;

Figure 4 shows a partly exploded front view in perspective of the Figure 1 packet of cigarettes in a closed configuration;

Figure 5 shows a front view in perspective of a sealed package of the Figure 1 packet of cigarettes;

Figure 6 shows a schematic side section, with parts removed for clarity, of a top portion of the Figure 1 packet of cigarettes;

Figures 7 and 8 show plan views of a sealing panel fixed to the Figure 11 blank using different types of adhesive;

Figure 9 shows a plan view of a sheet of packing material from which to form the Figure 5 sealed package;

Figure 10 shows a plan view of a variation of the Figure 9 sheet of packing material;

Figure 11 shows a plan view of a blank from which to form a container of the Figure 1 packet of cigarettes;

Figure 12 shows a plan view of the Figure 11 blank fitted with the sealing panel in Figures 7 and 8;

Figures 13 and 14 show plan views of two variations of the Figure 11 blank;

Figure 15 shows a front view in perspective of a variation of the Figure 1 packet of cigarettes in a closed configuration;

Figure 16 shows a front view in perspective of the Figure 15 packet of cigarettes in an open configuration;

Figure 17 shows a plan view of a blank from which to form a container of the Figure 15 packet of cigarettes.

PREFERRED EMBODIMENTS OF THE INVENTION

Number 1 in Figures 1, 2 and 3 indicates as a whole a rigid packet of cigarettes. Packet 1 of cigarettes comprises a cardboard outer container 2; and a soft sealed package 3 (shown more clearly in Figure 5) housed  
5 inside container 2.

Sealed package 3 encloses a parallelepiped-shaped group 4 of cigarettes (shown partly in Figure 3) and, at the top and front, has a cover flap 5 which, for access to group 4 of cigarettes, is movable between a closed  
10 position (Figure 5) in which cover flap 5 is coplanar with sealed package 3 to seal a corresponding extraction opening, and an open position (Figure 3) in which cover flap 5 is lifted off sealed package 3 to open the extraction opening. Cover flap 5 is defined by a cut 6  
15 (Figure 3) through sealed package 3 and which extends astride a top wall and front wall of sealed package 3, i.e. cut 6 defines both cover flap 5 and a corresponding extraction opening, so lifting up cover flap 5 allows access to the extraction opening. It is important to  
20 note that cut 6 may be a through cut from the outset, or may initially be a non-through cut (i.e. a non-through incision, to avoid impairing the seal of sealed package 3) which is torn when unsealing sealed package 3 (i.e. the first time packet 1 of cigarettes is opened). In  
25 other words, to open sealed package 3, cut 6 must be a through cut to lift cover flap 5 off the rest of sealed

package 3, but may initially be a non-through cut, which is torn when unsealing sealed package 3 (i.e. the first time packet 1 of cigarettes is opened).

Container 2 encloses sealed package 3 and, at the top and front, has a cover flap 7 which, for access to sealed package 3, is movable between a closed position (Figure 1) in which cover flap 7 is coplanar with container 2 to seal a corresponding extraction opening, and an open position (Figure 3) in which cover flap 7 is lifted up off container 2 to open the extraction opening. Cover flap 7 is defined by a cut 8 (Figure 3) through container 2 and which extends astride a top wall and front wall of container 2, i.e. cut 8 defines both cover flap 7 and a corresponding extraction opening, so lifting up cover flap 7 allows access to the extraction opening. Because container 2 (unlike sealed package 3) is not sealed, cut 8 is normally a through cut from the outset.

Cover flap 7 of container 2 is superimposed directly on and glued permanently to cover flap 5 of sealed package 3 by adhesive 9 (shown schematically in Figure 6). Adhesive 9 is preferably permanent drying adhesive, which therefore glues cover flaps 5 and 7 to each other non-separably (unless they are torn apart).

In a preferred embodiment shown in the attached drawings and clearly in Figure 3, cover flap 7 of

container 2 is larger (in area) than cover flap 5 of sealed package 3, i.e. cover flap 5 of sealed package 3 is contained entirely within cover flap 7 of container 2. In other words, each point along cut 6 of cover flap 5 is located a given (preferably constant) distance from cut 8 of cover flap 7. In a different embodiment not shown, cover flap 7 of container 2 is the same size (area) as cover flap 5 of sealed package 3. In other words, each point along cut 6 of cover flap 5 is superimposed on and aligned with cut 8 of cover flap 7 (this embodiment permits a larger cover flap 5 to facilitate withdrawal of the cigarettes from sealed package 3).

Packet 1 of cigarettes comprises a reclosable 'open-close' adhesive panel 10 on the outside of container 2 and superimposed directly on cover flap 7 of container 2. Adhesive panel 10 is larger (in area) than cover flap 7 of container 2 (as shown clearly in Figure 3), so cover flap 7 of container 2 is contained entirely within adhesive panel 10. In other words, each point along cut 8 of cover flap 7 is located a given distance from an edge of adhesive panel 10. On the inside (as shown schematically in Figure 6) adhesive panel 10 is coated with non-dry, re-stick adhesive 11, i.e. which remains sticky even after a long period of time, so adhesive panel 10 is glued permanently to cover flap 7

of container 2 and releasably to a portion of container 2 around cover flap 7 (i.e. around cut 8). Non-dry, re-stick adhesive 11 allows adhesive panel 10, even over a long period of time, to be detached and re-attached repeatedly from and to container 2.

Adhesive panel 10 has a grip tab 12 with no non-dry, re-stick adhesive 11 and located along the bottom edge of adhesive panel 10. Grip tab 12 serves to make adhesive panel 10 easier to grip and lift up. In other words, to lift up adhesive panel 10, the user simply grips grip tab 12, which is in no way fixed to container 2, unlike the rest of adhesive panel 10 which is fixed to container 2 by re-stick adhesive 11.

Normally, i.e. when packet 1 of cigarettes is not in use, adhesive panel 10 adheres to the portion of container 2 around cover flap 7 (i.e. around cut 8) to close (seal) packet 1 (i.e. to keep both cover flaps 5 and 7 in the closed position. And, to withdraw a cigarette from group 4, adhesive panel 10 may be pulled up temporarily (and partially) off container 2 to lift up both flaps 5 and 7 (i.e. into the open position).

Container 2 is in the form of a rectangular parallelepiped having a top wall 13 and an opposite parallel bottom wall 14; a front wall 15 and an opposite parallel rear wall 16; and two opposite parallel lateral walls 17. Four longitudinal edges are defined between

lateral walls 17 and front and rear walls 15, 16; and eight transverse edges are defined between top and bottom walls 13, 14 and front wall 15, rear wall 16, and lateral walls 17. In the embodiment shown in the drawings, all the edges are square. In other, perfectly equivalent, embodiments, some edges may obviously be bevelled or rounded.

Normally, i.e. when adhering to container 2 to seal packet 1 of cigarettes, adhesive panel 10 is U-shaped (as shown clearly in Figure 4) and superimposed on front wall 15, top wall 13, and rear wall 16 of container 2.

In one embodiment shown in Figure 7, non-dry, re-stick adhesive 11 covers the whole inner face of adhesive panel 10 (except, obviously, for grip tab 12, which has no re-stick adhesive 11). In this embodiment, non-dry, re-stick adhesive 11 between adhesive panel 10 and container 2 glues cover flap 7, enclosed within cut 8, to adhesive panel 10 permanently (i.e. so the two are never separated, even in use, though theoretically they could be). So, when adhesive panel 10 is pulled up off container 2, cover flap 7 enclosed within cut 8 is also pulled up together with adhesive panel 10. Non-dry, re-stick adhesive 11 between adhesive panel 10 and container 2 also glues the portion of container 2 surrounding cover flap 7 (i.e. surrounding cut 8) temporarily (i.e. detachably, in use) to adhesive panel

10, so as to normally keep adhesive panel 10 in contact with container 2 to close packet 1 of cigarettes.

In an alternative embodiment shown in Figure 8, a further, permanent drying, adhesive 18 is interposed between adhesive panel 10 and cover flap 7 of container 2 to glue adhesive panel 10 and cover flap 7 to each other non-detachably (unless they are torn apart). The purpose of further, permanent drying, adhesive 18 is to form a stronger, more stable connection between adhesive panel 10 and cover flap 7 of container 2. Further, permanent drying, adhesive 18 preferably covers an inner portion of adhesive panel 10 smaller (in area) than cover flap 7 of container 2, so as to ensure that, regardless of all possible manufacturing tolerances, further, permanent drying, adhesive 18 always remains within cover flap 7 of container 2, at a given distance from cut 8 (i.e. never crosses over cut 8 defining cover flap 7). In fact, if further, permanent drying, adhesive 18 were to cross over cut 8, this would result in adhesive panel 10 and the portion of container 2 surrounding cover flap 7 (i.e. surrounding cut 8) being connected non-detachably (unless they are torn apart).

As shown in Figure 9, sealed package 3 is formed by folding a rectangular sheet 19 of packing material having cut 6 defining cover flap 5. In the Figure 9 embodiment, cut 6 is defined by an endless line, which

means cover flap 5 is detached completely from sealed package 3, i.e. has no points that remain connected to the rest of sealed package 3. To handle and process (fold) sheet 19 of packing material, cut 6 has at least one initially undetached portion which is torn the first time cover flap 5 (i.e. packet 1 of cigarettes) is opened. As stated, initially, cut 6 is preferably a non-through cut to preserve the integrity (i.e. seal) of sealed package 3, and is torn through when unsealing sealed package 3 (i.e. packet 1 of cigarettes). In the Figure 10 embodiment, cut 6 is defined by an open, U-shaped line, which means cover flap 5 has one side that remains connected to sealed package 3.

As shown in Figure 11, container 2 of packet 1 of cigarettes is formed from a blank 20 which, among other things, comprises a number of parts which, where possible, are indicated using the same reference numbers, with superscripts, as for the corresponding walls of container 2.

As shown in Figure 11, cover flap 7 of container 2 is connected to container 2 along a hinge 21, so as to move between the open and closed positions by rotating about hinge 21. And cut 8 is U-shaped, with two ends resting on hinge 21.

As shown in Figure 11, blank 20 has two longitudinal fold lines 22, and a number of transverse

fold lines 23 which define, between longitudinal fold lines 22, a panel 14' forming an outer portion of bottom wall 14 of container 2; a panel 15' forming front wall 15 of container 2; a panel 13' forming top wall 13 of container 2; a panel 16' forming rear wall 16 of container 2; and a panel 14" forming an inner portion of bottom wall 14 of container 2, and which, when folding blank 20, is superimposed on and glued to panel 14'.

Panel 15' has two wings 17', which form respective outer portions of lateral walls 17 of container 2, are located on opposite sides of panel 15', and are connected to panel 15' by longitudinal fold lines 22. Panel 16' has two wings 17", which form respective inner portions of lateral walls 17 of container 2, are located on opposite sides of panel 16', and are connected to panel 16' by longitudinal fold lines 22.

Each wing 17" has a fastening tab 24 connected to wing 17" along a transverse fold line 23, and which, when folding blank 20, is folded 90° with respect to wing 17" and glued to the inner surface of panel 14". Each wing 17" also has a fastening tab 25 connected to wing 17" along a transverse fold line 23, at the opposite end to fastening tab 24, and which, when folding blank 20, is folded 90° with respect to wing 17" and glued to the inner surface of panel 13'. Each fastening tab 25 is small enough not to overlap cut 8

(i.e. cover flap 7).

Figure 12 shows the Figure 11 blank 20 fitted with adhesive panel 10. Adhesive panel 10, in fact, is preferably fitted (glued) to blank 20 before folding  
5 blank 20, together with adhesive panel 10, about sealed package 3 to form container 2 of packet 1 of cigarettes.

Figure 13 shows a different embodiment of blank 20, in which transverse fold lines 23 define, between the two longitudinal fold lines 22, a panel 13' forming an  
10 inner portion of top wall 13 of container 2; a panel 16' forming rear wall 16 of container 2; a panel 14' forming bottom wall 14 of container 2; a panel 15' forming front wall 15 of container 2; and a panel 13" forming an outer portion of top wall 13 of container 2, and which, when  
15 folding blank 20, is superimposed on and glued to panel 13'.

Figure 14 shows a variation of the Figure 13 blank 20, which is identical to the Figure 13 blank 20 except for the shape and size of panel 13' and fastening tabs  
20 25, and the shape of cut 8.

In the Figure 1-14 embodiments, hinge 21 of cover flap 7 of container 2 is located along a rear transverse edge of top wall 13 of container 2, i.e. is superimposed on (coaxial with) the rear transverse edge of top wall  
25 13. In this embodiment, cut 6 is preferably defined by an endless line (as shown in Figure 9), so that cover

flap 5 is detached completely from sealed package 3. In fact, when hinge 21 of cover flap 7 is located along the rear transverse edge of top wall 13, cover flap 5 is best detached completely from sealed package 3 to avoid  
5 severe stress (and therefore deformation) of sealed package 3 when opening adhesive panel 10.

In the Figure 15-17 embodiments, hinge 21 of cover flap 7 of container 2 is located on top wall 13 of container 2, between and a given distance from a front  
10 transverse edge and rear transverse edge of top wall 13. In this embodiment, cut 6 may be defined by an endless line (as shown in Figure 9), or by a U-shaped line (as shown in Figure 10). In fact, this embodiment, in which hinge 21 of cover flap 7 is located a given distance  
15 from the rear transverse edge of top wall 13, produces no severe stress (or deformation) of sealed package 3 when opening adhesive panel 10, even when cut 6 is defined by a U-shaped line (as shown in Figure 10).

Packet 1 of cigarettes described has numerous  
20 advantages.

Firstly, packet 1 of cigarettes described can be opened/closed in one operation (i.e. a single movement by the user) and as such is extremely easy, quick, and intuitive to use.

25 Secondly, packet 1 of cigarettes described is cheap and easy to make, by being producible on a substantially

standard packing machine equipped with an additional application station for applying adhesive panels 10 beforehand to blanks 20 (as shown in Figures 12-14 and 17).

5        Lastly, packet 1 of cigarettes described can be made from a relatively small amount of packing material, in that adhesive panel 10 is relatively thin (compared with the thickness of sheet 19 of packing material and blank 20) and so does not significantly increase the  
10 total amount of packing material required.

In the non-limiting embodiment shown in the attached drawings, packet 1 according to the invention contains a group 4 of cigarettes; but, given its numerous advantages, packet 1 according to the present  
15 invention may also be used for other than cigarettes, such as foodstuffs (sweets, chocolates or other confectionary).

## CLAIMS

1) A packet (1) comprising:  
a group (4) of articles;

5 a sealed package (3) enclosing the group (4) of articles and having a first cover flap (5), which is defined by a first cut (6) through the sealed package (3) and is movable to allow access to the group (4) of articles;

10 a rigid container (2) enclosing the sealed package (3) and having a second cover flap (7), which is defined by a second cut (8) through the container (2), is superimposed on the first cover flap (5) of the sealed package (3), and is movable to allow access to the  
15 sealed package (3); and

a reclosable adhesive panel (10), which is coated on the inside with a first re-stick adhesive (11), and has at least one grip tab (12) with no first re-stick adhesive (11) and located at an edge of the adhesive  
20 panel (10);

the packet (1) being **characterized in that:**

the second cover flap (7) is superimposed directly on the first cover flap (5), and is glued permanently to the first cover flap (5); and

25 the adhesive panel (10) is located outside the container (2), is larger than the second cover flap (7), is superimposed on the second cover flap (7), is glued permanently to the second cover flap (7), and is glued releasably by the first re-stick adhesive (11) to a  
30 portion of the container (2) surrounding the second cover flap (7).

2) A packet (1) as claimed in Claim 1, wherein the second cover flap (7) is connected to the container (2)

along a hinge (21).

3) A packet (1) as claimed in Claim 2, wherein the second cut (8) is U-shaped, and has two ends resting on the hinge (21).

5 4) A packet (1) as claimed in Claim 2 or 3, wherein the hinge (21) is located at a rear transverse edge of a top wall (13) of the container (2).

5) A packet (1) as claimed in Claim 2 or 3, wherein the hinge (21) is located on a top wall (13) of the  
10 container (2), between a front transverse edge and a rear transverse edge of the top wall (13), and at a given distance from both the front transverse edge and the rear transverse edge.

6) A packet (1) as claimed in one of Claims 1 to 5,  
15 wherein the first cut (6) is defined by an endless line.

7) A packet (1) as claimed in Claim 6, wherein the first cover flap (5) is detached completely from the sealed package (3).

8) A packet (1) as claimed in Claim 6 or 7, wherein  
20 the first cut (6) comprises at least one initially undetached portion, which is torn when the first cover flap (5) is first opened.

9) A packet (1) as claimed in one of Claims 1 to 5, wherein the first cut (6) is U-shaped.

25 10) A packet (1) as claimed in one of Claims 1 to 9, wherein the second cover flap (7) is glued permanently to the first cover flap (5) by a second permanent, drying adhesive (9).

11) A packet (1) as claimed in one of Claims 1 to  
30 10, wherein the adhesive panel (10) is glued permanently to the second cover flap (7) solely by the first re-stick adhesive (11).

12) A packet (1) as claimed in one of Claims 1 to

10, wherein the adhesive panel (10) is also glued permanently to the second cover flap (7) by a third permanent, drying adhesive (18).

13) A packet (1) as claimed in Claim 12, wherein  
5 the third permanent, drying adhesive (18) covers an inner area of the adhesive panel (10) smaller than the second cover flap (7).

14) A packet (1) as claimed in one of Claims 1 to  
13, wherein the second cover flap (7) is larger than the  
10 first cover flap (5).

15) A packet (1) as claimed in one of Claims 1 to  
14, wherein the container (2) is formed by folding a  
blank (20) having two longitudinal fold lines (22), and  
a number of transverse fold lines (23) which define,  
15 between the two longitudinal fold lines (22):

a first panel (14') forming an outer portion of a  
bottom wall (14) of the container (2);

a second panel (15') forming a front wall (15) of  
the container (2);

20 a third panel (13') forming a top wall (13) of the  
container (2);

a fourth panel (16') forming a rear wall (16) of  
the container (2); and

a fifth panel (14'') forming an inner portion of the  
25 bottom wall (14) of the container (2), and which is  
superimposed on and glued to the first panel (14') when  
folding the blank (20).

16) A packet (1) as claimed in Claim 15, wherein:

30 the second panel (15') has two first wings (17'),  
which form respective outer portions of the lateral  
walls (17) of the container (2), are located on opposite  
sides of the second panel (15'), and are connected to  
the second panel (15') by the longitudinal fold lines

(22);

the fourth panel (16') has two second wings (17"), which form respective inner portions of the lateral walls (17) of the container (2), are located on opposite sides of the fourth panel (16'), and are connected to the fourth panel (16') by the longitudinal fold lines (22);

each second wing (17") has a first fastening tab (24), which is connected to the second wing (17") along a transverse fold line (23) and, when folding the blank (20), is folded 90° with respect to the second wing (17") and glued to an inner surface of the fifth panel (14"); and

each second wing (17") has a second fastening tab (25), which is connected to the second wing (17") along a transverse fold line (23), at the opposite end from the first fastening tab (24), and which, when folding the blank (20), is folded 90° with respect to the second wing (17") and glued to an inner surface of the third panel (13').

17) A packet (1) as claimed in Claim 16, wherein each second fastening tab (25) is small, so as not to overlap the second cut (8).

18) A packet (1) as claimed in one of Claims 1 to 14, wherein the container (2) is formed by folding a blank (20) having two longitudinal fold lines (22), and a number of transverse fold lines (23) which define, between the two longitudinal fold lines (22):

a first panel (13') forming an inner portion of a top wall (13) of the container (2);

a second panel (16') forming a rear wall (16) of the container (2);

a third panel (14') forming a bottom wall (14) of

the container (2);

a fourth panel (15') forming a front wall (15) of the container (2); and

5 a fifth panel (13") forming an outer portion of the top wall (13) of the container (2), and which is superimposed on and glued to the first panel (13') when folding the blank (20).

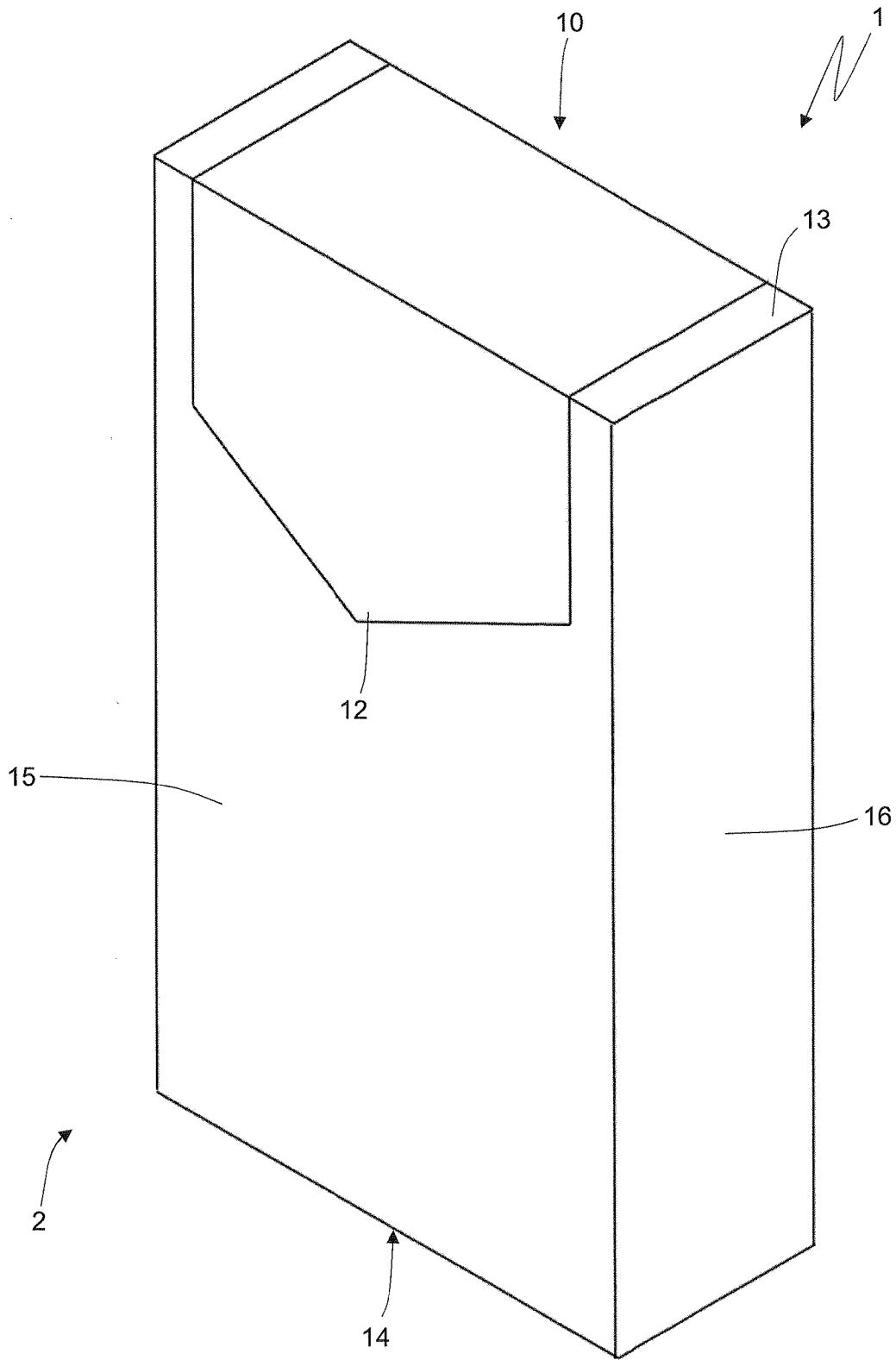

Fig.1

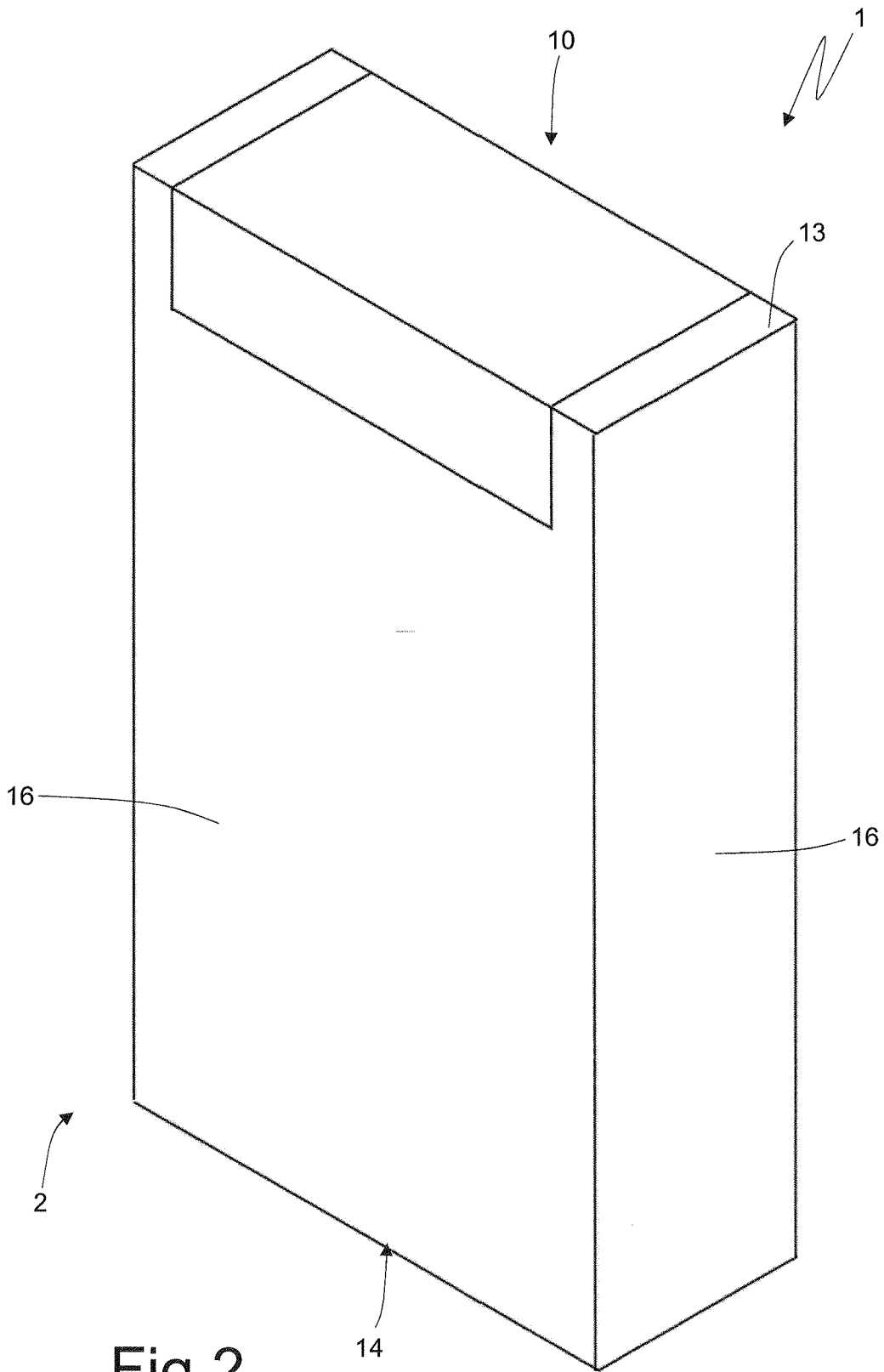

Fig.2

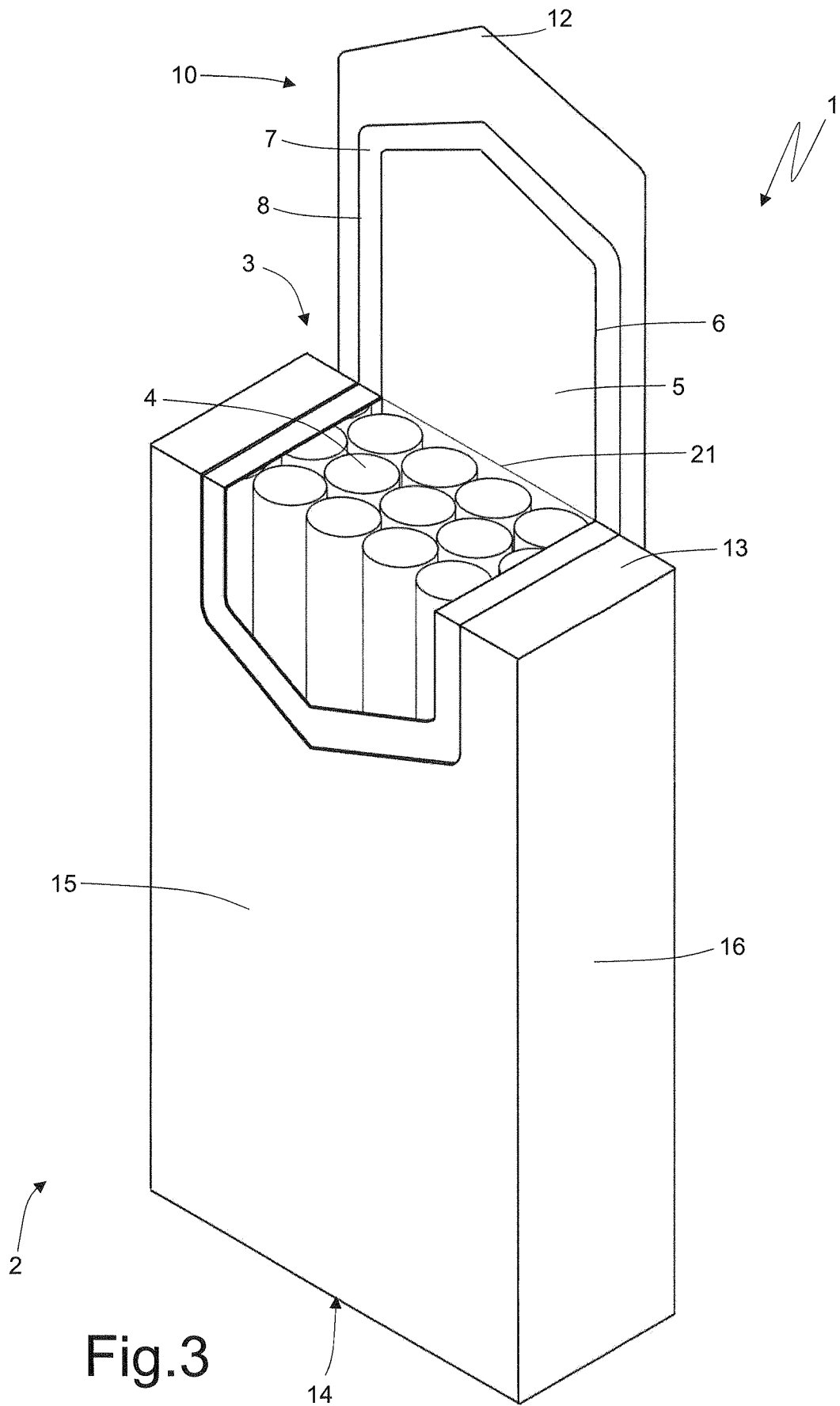

Fig.3

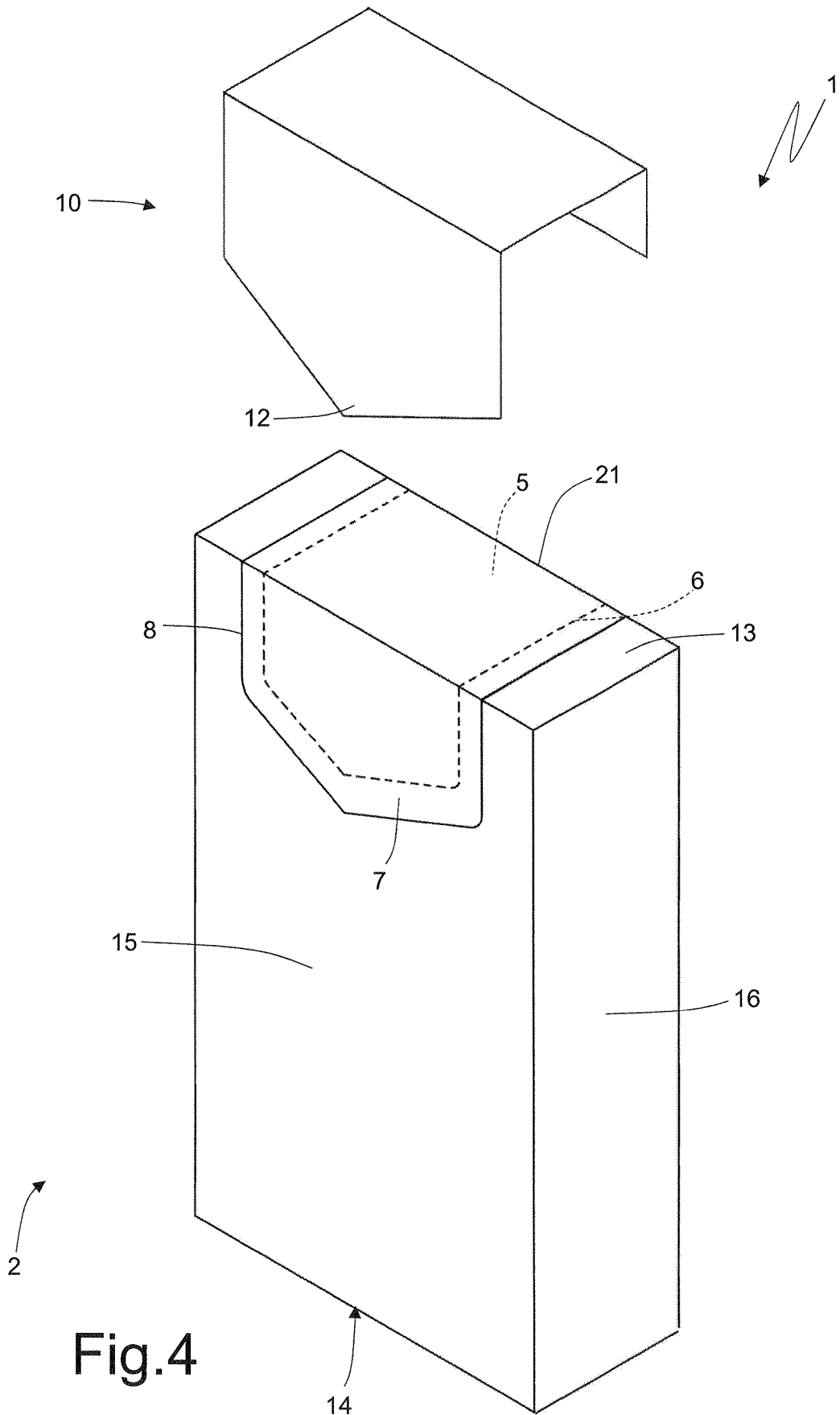

Fig.4

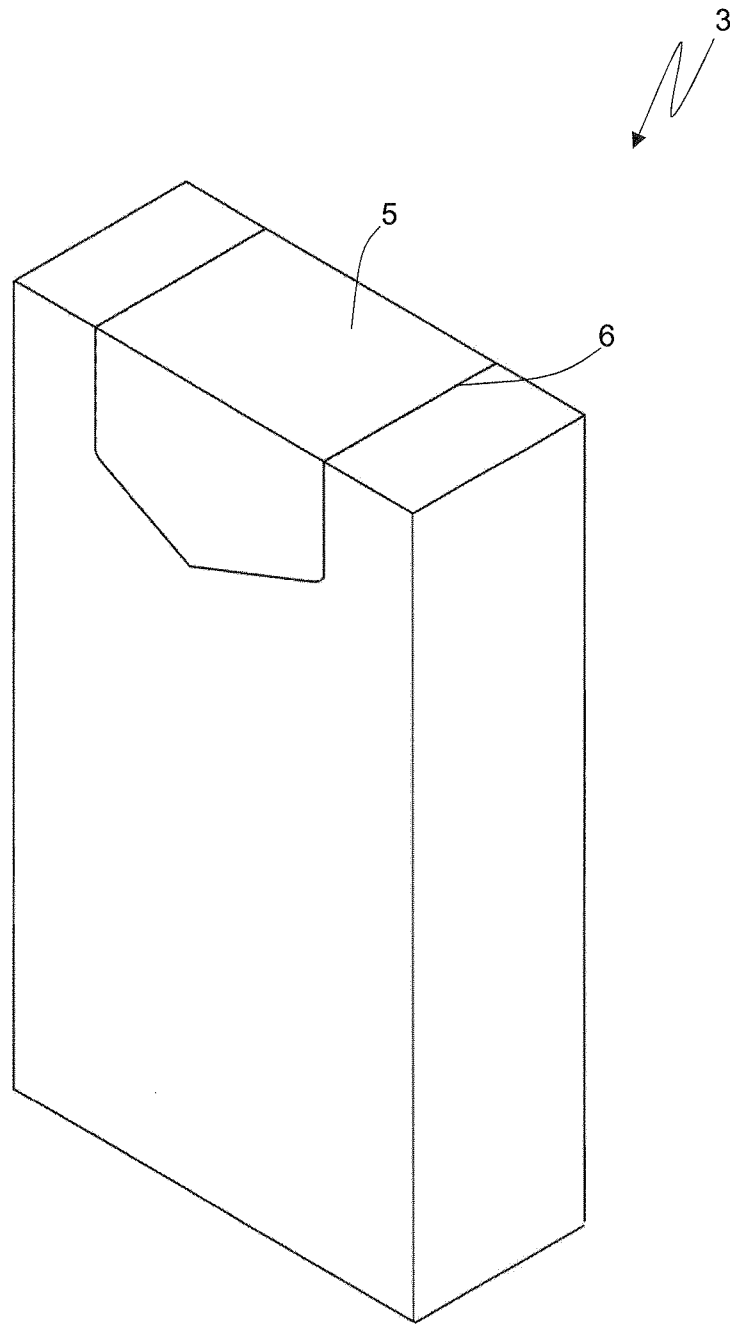

Fig.5

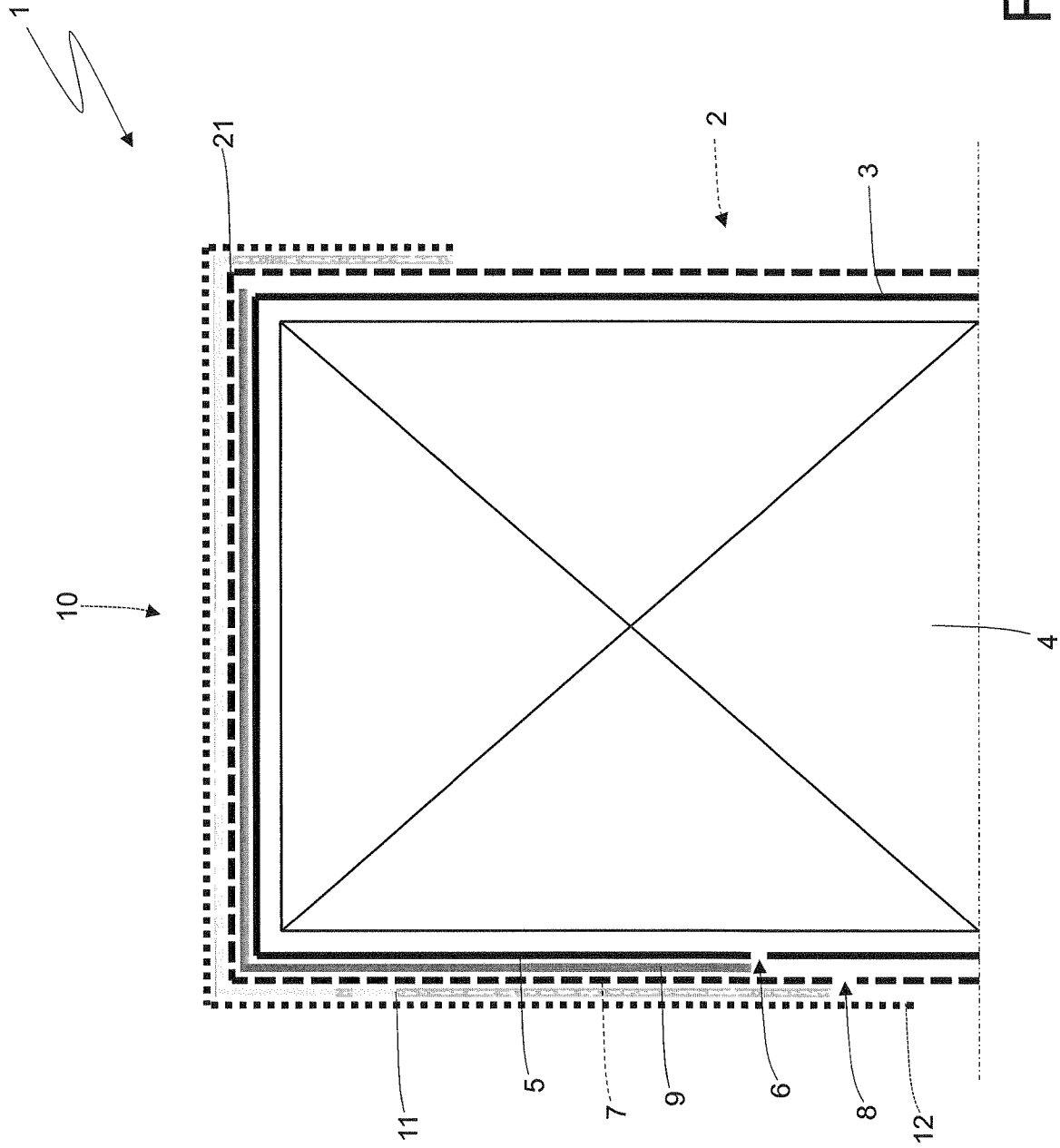

Fig.6

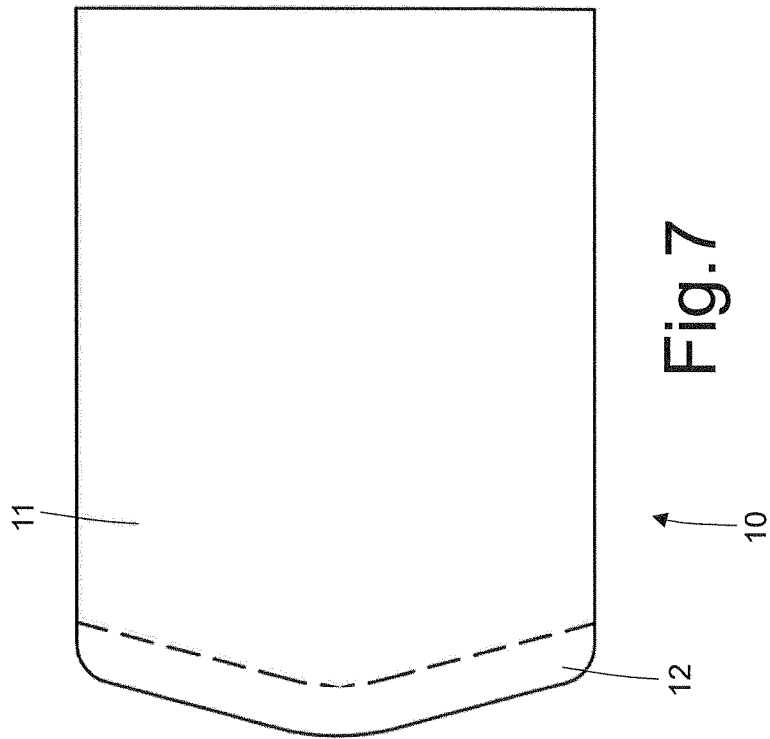
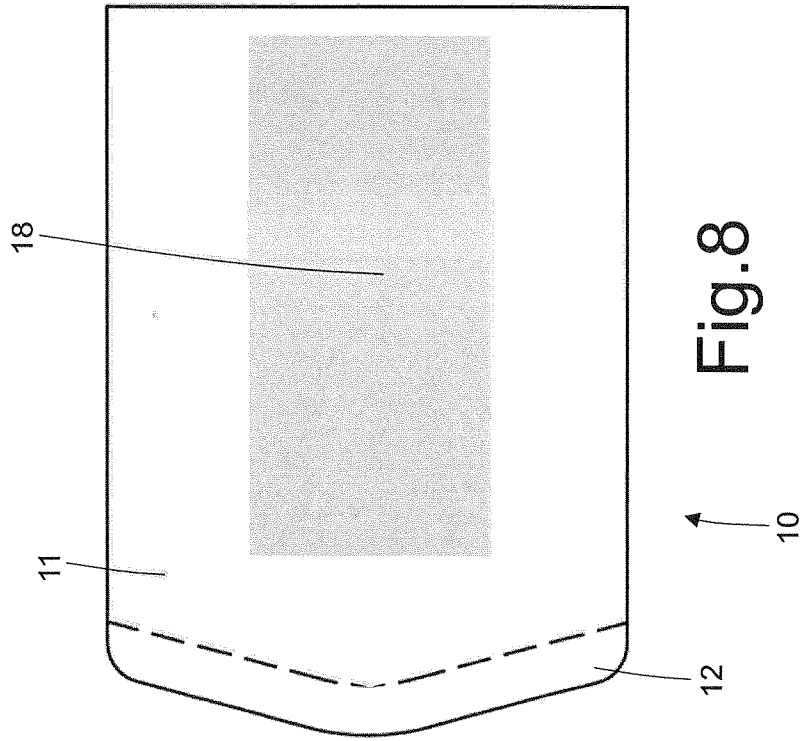

Fig. 8

Fig. 7

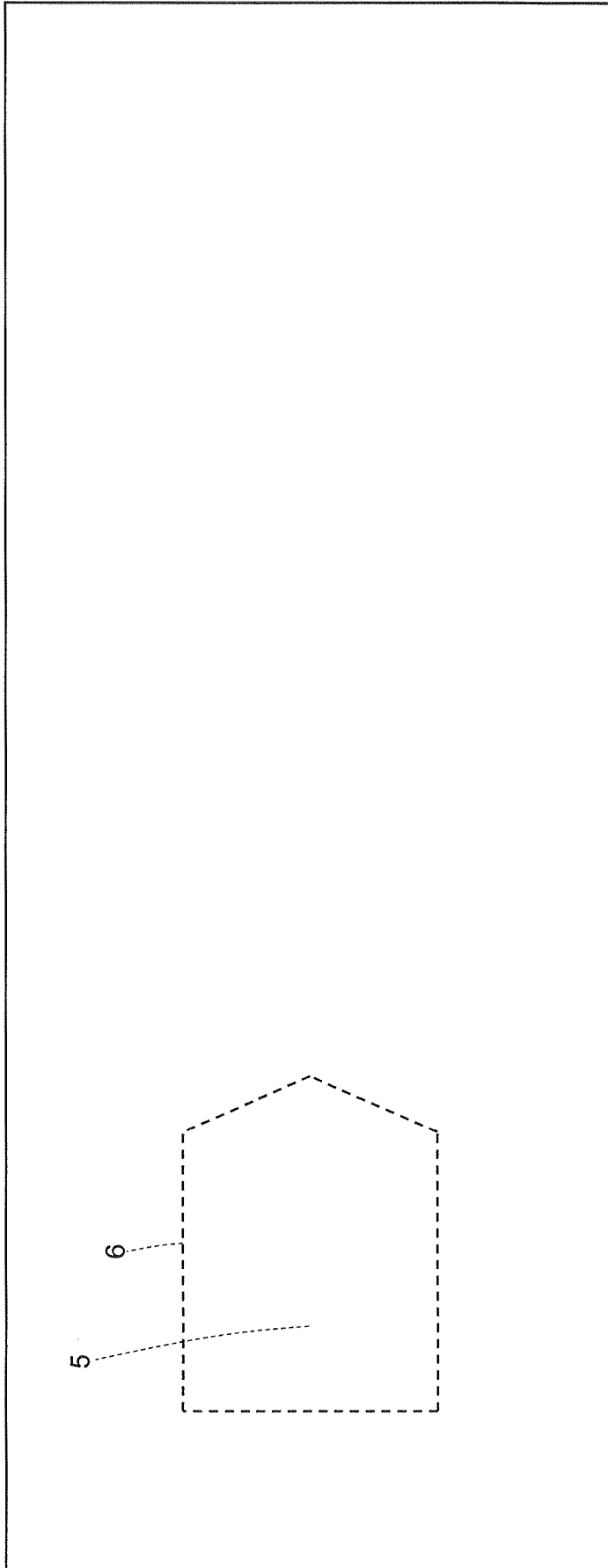
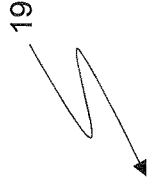

Fig.9

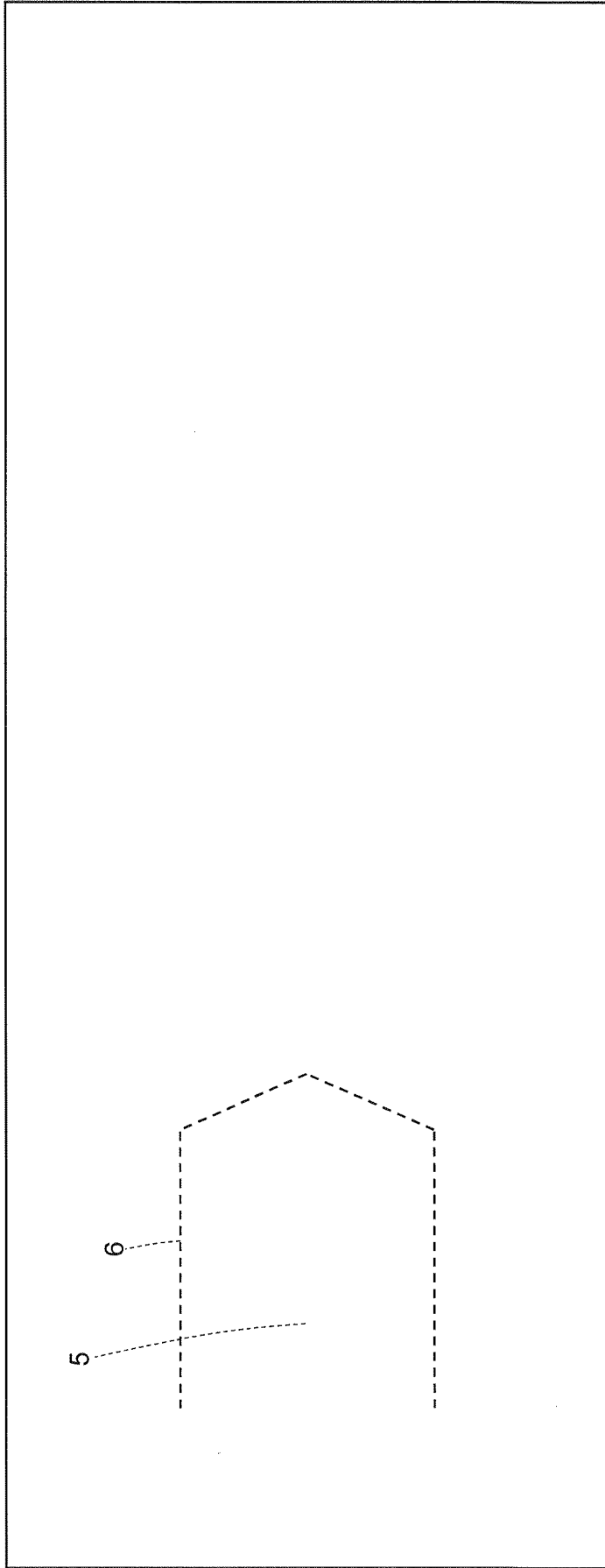
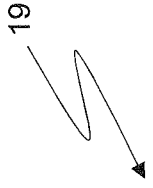

Fig.10



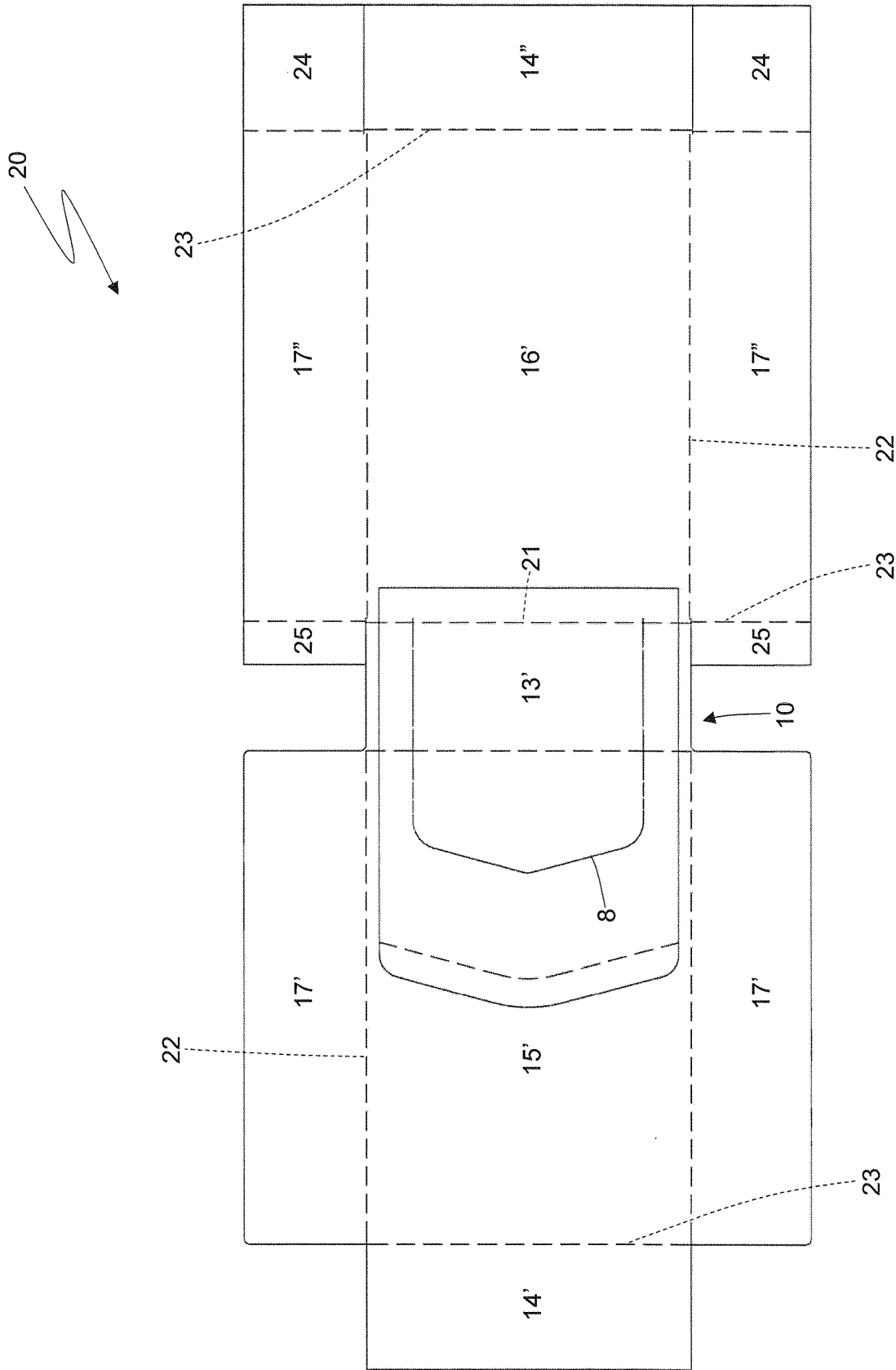

Fig.12

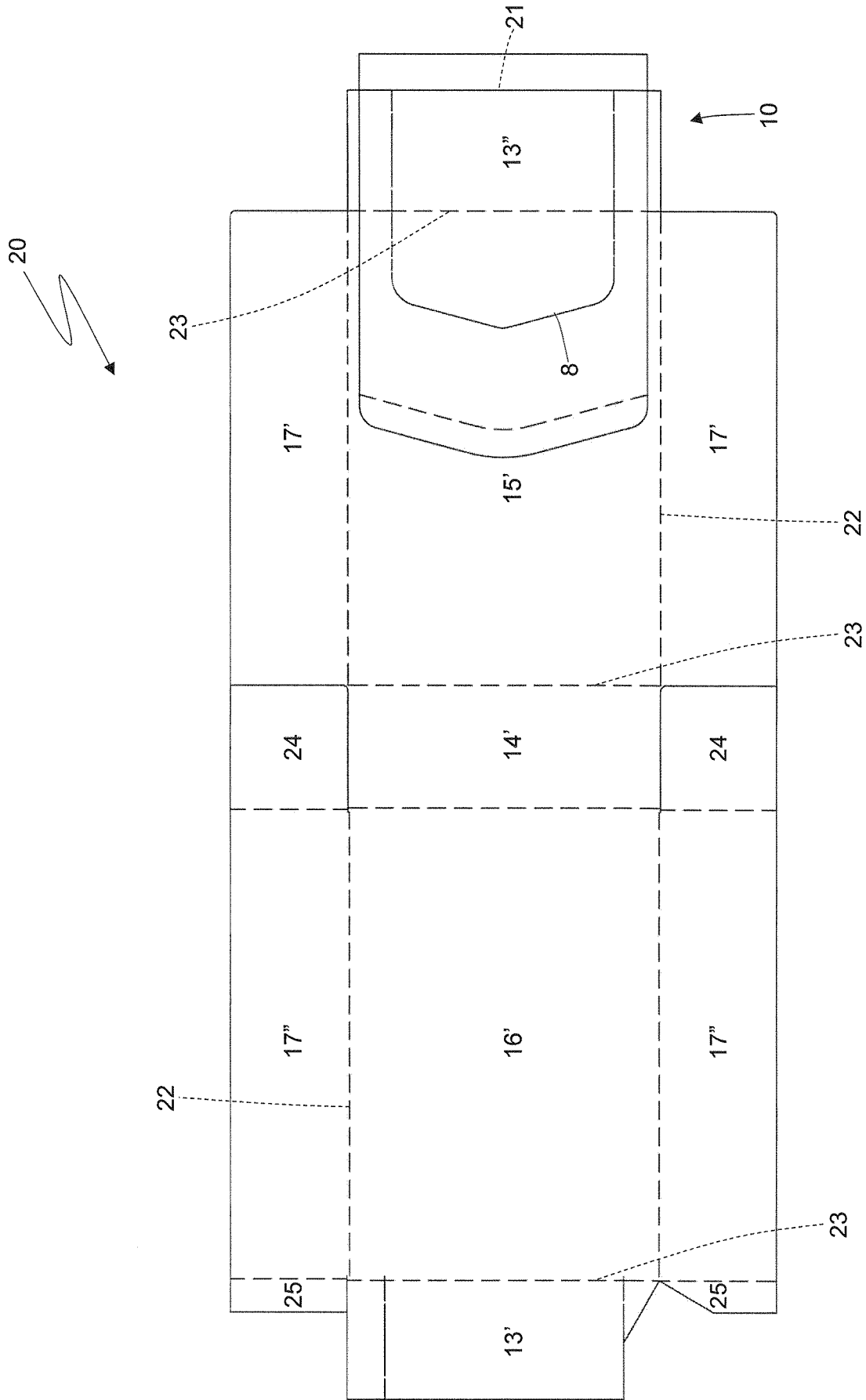

Fig.13

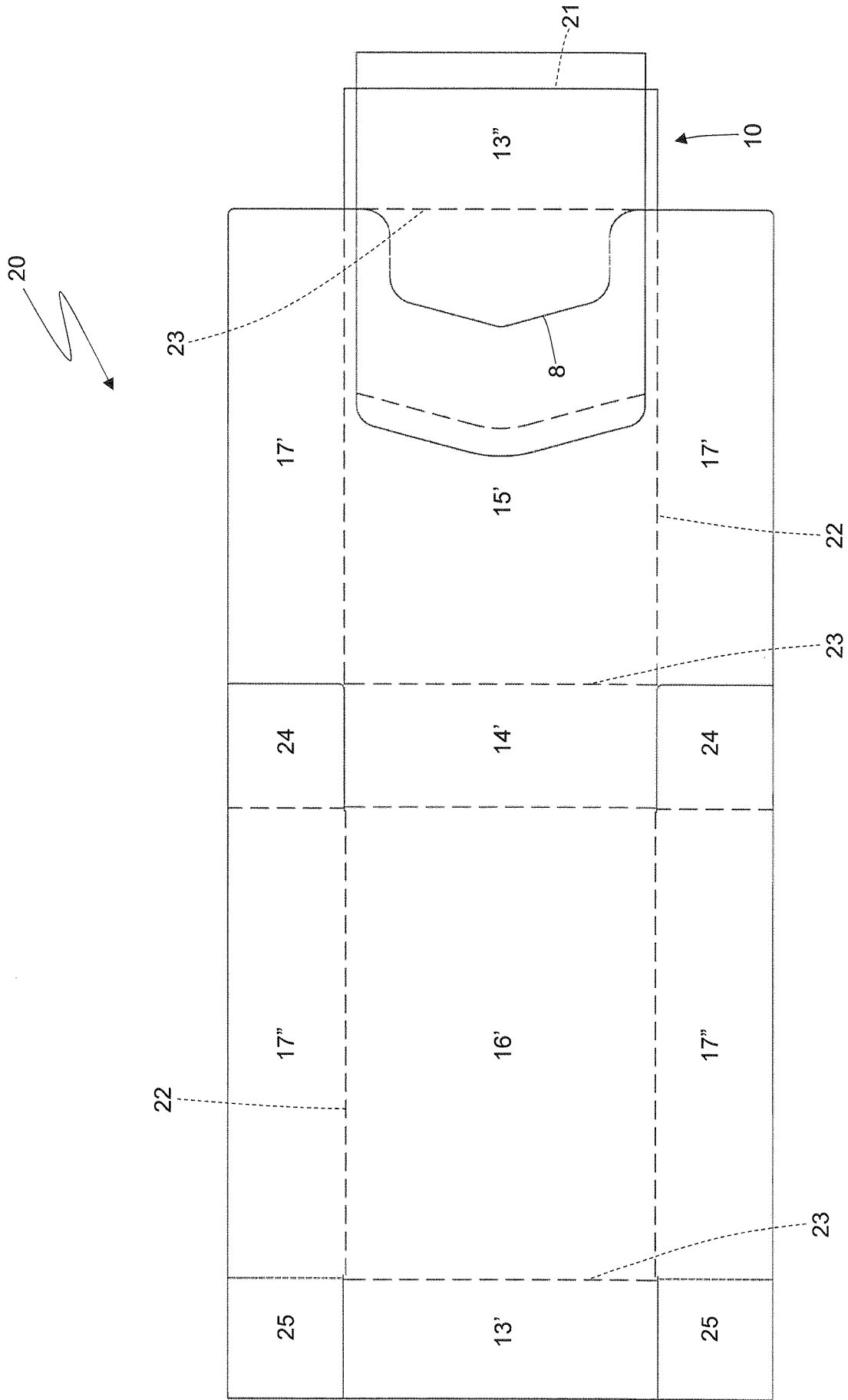

Fig.14

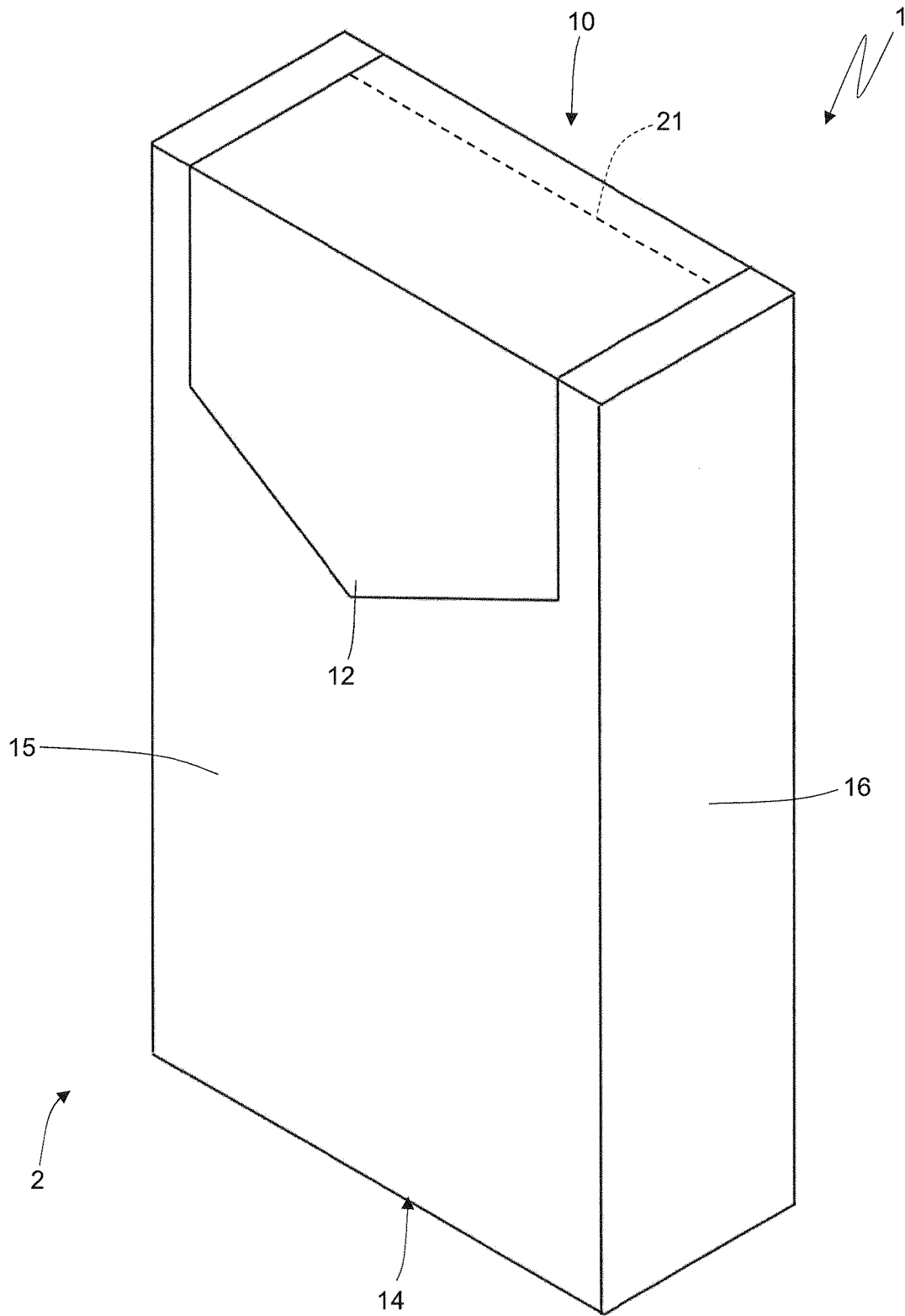
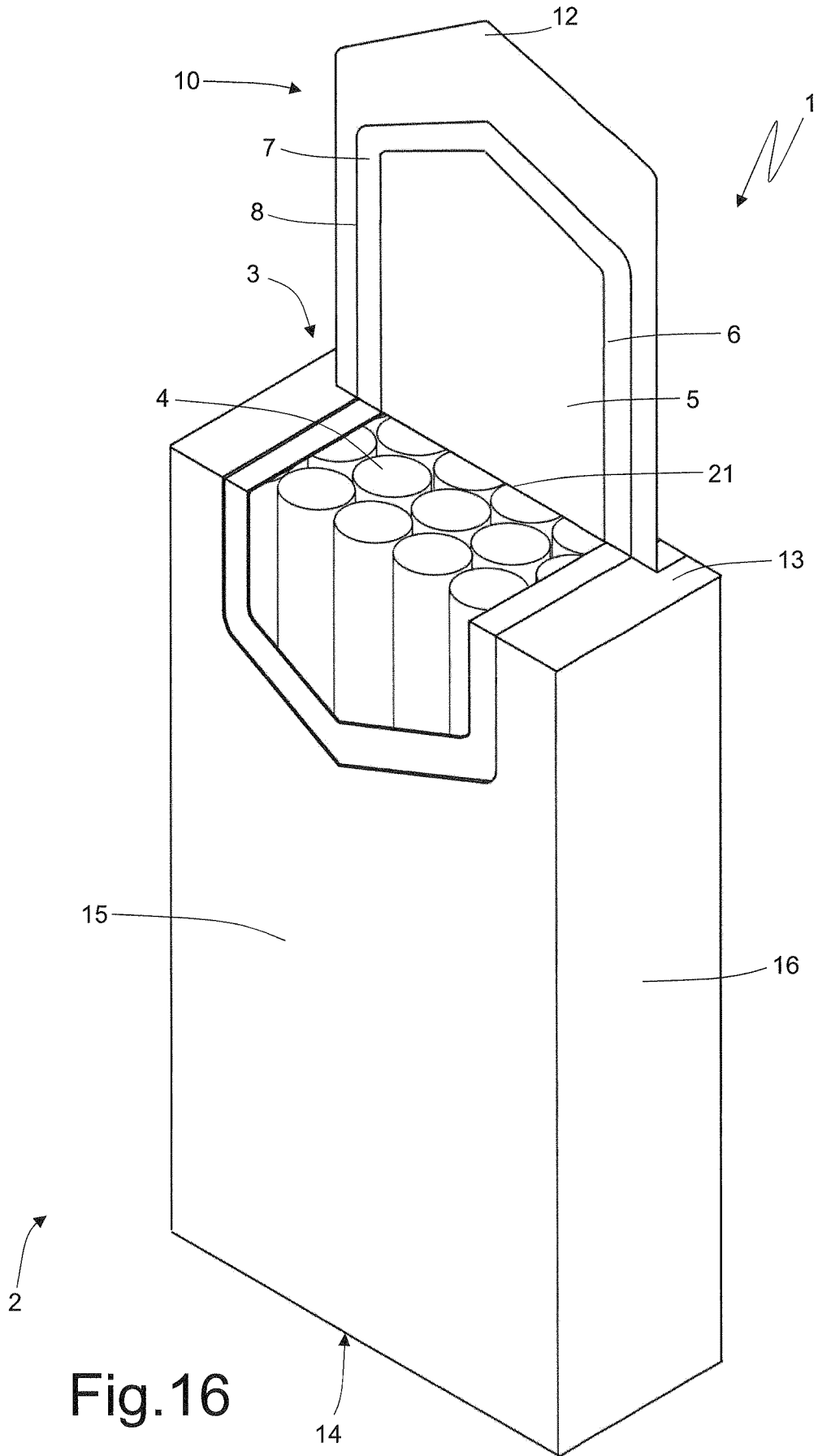

Fig.15





## INTERNATIONAL SEARCH REPORT

International application No  
PCT/IB2014/061597A. CLASSIFICATION OF SUBJECT MATTER  
INV. B65D85/10 B65D5/54  
ADD.

According to International Patent Classification (IPC) or to both national classification and IPC

## B. FIELDS SEARCHED

Minimum documentation searched (classification system followed by classification symbols)  
B65D

Documentation searched other than minimum documentation to the extent that such documents are included in the fields searched

Electronic data base consulted during the international search (name of data base and, where practicable, search terms used)

EPO-Internal

## C. DOCUMENTS CONSIDERED TO BE RELEVANT

Category*	Citation of document, with indication, where appropriate, of the relevant passages	Relevant to claim No.
Y	US 2012/111746 A1 (TANBO HITOSHI [JP] ET AL) 10 May 2012 (2012-05-10) the whole document	1-12, 14-18
Y	US 2011/233080 A1 (BERTUZZI IVANOE [IT] ET AL) 29 September 2011 (2011-09-29) the whole document	1-12, 14-18
Y	US 6 478 149 B1 (PARKER MICHAEL PATRICK [GB]) 12 November 2002 (2002-11-12) the whole document	16-18
A		1-15
A	US 2011/114518 A1 (HEIN VIKTOR [DE]) 19 May 2011 (2011-05-19) the whole document	1-18
	-/--	

 Further documents are listed in the continuation of Box C. See patent family annex.

\* Special categories of cited documents :

"A" document defining the general state of the art which is not considered to be of particular relevance

"E" earlier application or patent but published on or after the international filing date

"L" document which may throw doubts on priority claim(s) or which is cited to establish the publication date of another citation or other special reason (as specified)

"O" document referring to an oral disclosure, use, exhibition or other means

"P" document published prior to the international filing date but later than the priority date claimed

"T" later document published after the international filing date or priority date and not in conflict with the application but cited to understand the principle or theory underlying the invention

"X" document of particular relevance; the claimed invention cannot be considered novel or cannot be considered to involve an inventive step when the document is taken alone

"Y" document of particular relevance; the claimed invention cannot be considered to involve an inventive step when the document is combined with one or more other such documents, such combination being obvious to a person skilled in the art

"&amp;" document member of the same patent family

Date of the actual completion of the international search

26 August 2014

Date of mailing of the international search report

03/09/2014

Name and mailing address of the ISA/

European Patent Office, P.B. 5818 Patentlaan 2  
NL - 2280 HV Rijswijk  
Tel. (+31-70) 340-2040,  
Fax: (+31-70) 340-3016

Authorized officer

Pernice, Ciro

## INTERNATIONAL SEARCH REPORT

International application No  
PCT/IB2014/061597

C(Continuation). DOCUMENTS CONSIDERED TO BE RELEVANT

Category*	Citation of document, with indication, where appropriate, of the relevant passages	Relevant to claim No.
A	US 2009/308766 A1 (POLLONI ROBERTO [IT] ET AL) 17 December 2009 (2009-12-17) the whole document	1-18
A	----- DE 10 2009 034705 A1 (FOCKE & CO [DE]) 27 January 2011 (2011-01-27) the whole document -----	1-18

## INTERNATIONAL SEARCH REPORT

Information on patent family members

International application No

PCT/IB2014/061597

Patent document cited in search report	Publication date	Patent family member(s)	Publication date	
US 2012111746	A1	10-05-2012	CN 102470973 A	23-05-2012
			EP 2455302 A1	23-05-2012
			ES 2435624 T3	20-12-2013
			JP 5196688 B2	15-05-2013
			KR 20120024859 A	14-03-2012
			US 2012111746 A1	10-05-2012
			WO 2011007422 A1	20-01-2011
-----				
US 2011233080	A1	29-09-2011	EP 2361839 A1	31-08-2011
			RU 2011106780 A	27-08-2012
			US 2011233080 A1	29-09-2011
-----				
US 6478149	B1	12-11-2002	AT 233218 T	15-03-2003
			AU 731922 B2	05-04-2001
			AU 1343899 A	16-06-1999
			BG 65175 B1	31-05-2007
			BR 9815150 A	10-10-2000
			CA 2309915 A1	10-06-1999
			CN 1280545 A	17-01-2001
			CZ 20002068 A3	16-01-2002
			DE 69811725 D1	03-04-2003
			DE 69811725 T2	18-09-2003
			DK 1037822 T3	31-03-2003
			EG 21659 A	27-02-2002
			EP 1037822 A1	27-09-2000
			ES 2189272 T3	01-07-2003
			HK 1030919 A1	05-09-2003
			HU 0100425 A2	28-06-2001
			ID 21712 A	15-07-1999
			IL 136298 A	17-09-2003
			JO 2050 B	15-05-1999
			JP 3981404 B2	26-09-2007
			JP 2001524429 A	04-12-2001
			MY 120062 A	30-08-2005
			NZ 504556 A	27-09-2002
			PL 340911 A1	12-03-2001
			PT 1037822 E	30-06-2003
			RU 2203206 C2	27-04-2003
			SI 1037822 T1	30-06-2003
			TR 200001574 T2	21-12-2000
			US 6478149 B1	12-11-2002
			US 2003047470 A1	13-03-2003
			WO 9928212 A1	10-06-1999
			ZA 9810983 A	01-06-1999
			-----	
US 2011114518	A1	19-05-2011	CN 102112378 A	29-06-2011
			DE 102008035467 A1	04-02-2010
			EP 2310300 A1	20-04-2011
			JP 5398832 B2	29-01-2014
			JP 2011529421 A	08-12-2011
			US 2011114518 A1	19-05-2011
			WO 2010012370 A1	04-02-2010
-----				
US 2009308766	A1	17-12-2009	CN 201553413 U	18-08-2010
			EP 2133278 A1	16-12-2009
			JP 2009298482 A	24-12-2009
			US 2009308766 A1	17-12-2009
-----				

# INTERNATIONAL SEARCH REPORT

Information on patent family members

International application No  
PCT/IB2014/061597

Patent document cited in search report	Publication date	Patent family member(s)	Publication date
DE 102009034705 A1	27-01-2011	DE 102009034705 A1	27-01-2011
		EP 2456685 A1	30-05-2012
		WO 2011009520 A1	27-01-2011
-----			