

(19) World Intellectual Property Organization
International Bureau



(43) International Publication Date
27 February 2003 (27.02.2003)

PCT

(10) International Publication Number
WO 03/015664 A1

- (51) International Patent Classification⁷: **A61F 2/06**
- (21) International Application Number: PCT/US02/17609
- (22) International Filing Date: 5 June 2002 (05.06.2002)
- (25) Filing Language: English
- (26) Publication Language: English
- (30) Priority Data:

60/314,259	20 August 2001 (20.08.2001)	US
09/948,989	7 September 2001 (07.09.2001)	US
- (63) Related by continuation (CON) or continuation-in-part (CIP) to earlier application:

US	09/948,989 (CON)
Filed on	7 September 2001 (07.09.2001)
- (71) Applicant (for all designated States except US): **CONOR MEDSYSTEMS, INC.** [US/US]; 2468 Embarcadero Way, Palo Alto, CA 94303 (US).
- (72) Inventors; and
- (75) Inventors/Applicants (for US only): **SHANLEY, John, F.** [US/US]; 401 Camberly Way, Redwood City, CA 94061 (US). **EIGLER, Neal, L.** [US/US]; 459 Surfview Drive, Pacific Palisades, CA 90272 (US). **PARK, Kinam** [KR/US]; 455 Lagrange Street, West Lafayette, IN 47906 (US). **EDELMAN, Elazer, R.** [US/US]; 30 Warren Street, Brookline, MA 02445 (US).
- (74) Agent: **PETERSON, James, W.**; Burns, Doane, Swecker & Mathis, LLP, P.O. Box 1404, Alexandria, VA 22314-2756 (US).
- (81) Designated States (national): AE, AG, AL, AM, AT, AU, AZ, BA, BB, BG, BR, BY, BZ, CA, CH, CN, CO, CR, CU, CZ, DE, DK, DM, DZ, EC, EE, ES, FI, GB, GD, GE, GH, GM, HR, HU, ID, IL, IN, IS, JP, KE, KG, KP, KR, KZ, LC, LK, LR, LS, LT, LU, LV, MA, MD, MG, MK, MN, MW, MX, MZ, NO, NZ, OM, PH, PL, PT, RO, RU, SD, SE, SG, SI, SK, SL, TJ, TM, TN, TR, TT, TZ, UA, UG, US, UZ, VN, YU, ZA, ZM, ZW.

[Continued on next page]

(54) Title: EXPANDABLE MEDICAL DEVICE FOR DELIVERY OF BENEFICIAL AGENT

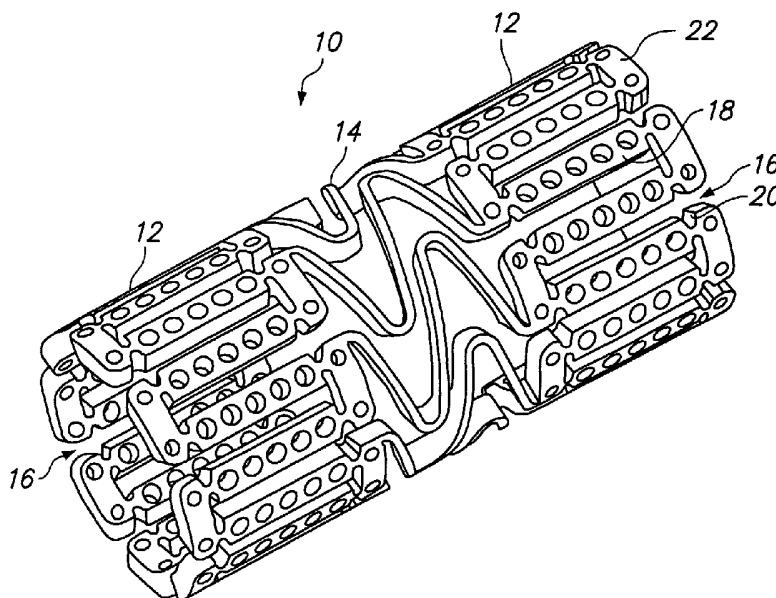

(57) Abstract: An expandable medical device has a plurality of elongated struts joined together to form a substantially cylindrical device which is expandable from a cylinder having a first diameter to a cylinder having a second diameter. At least one of the plurality of struts includes at least one opening extending at least partially through a thickness of said strut. A beneficial agent is loaded into the opening within the strut in layers to achieve desired temporal release kinetics of the agent. Alternatively, the beneficial agent is loaded in a shape which is configured to achieve the desired agent delivery profile. A wide variety of delivery profiles can be achieved including zero order, pulsatile, increasing, decrease, sinusoidal, and other delivery profiles.



WO 03/015664 A1



(84) Designated States (regional): ARIPO patent (GH, GM, KE, LS, MW, MZ, SD, SL, SZ, TZ, UG, ZM, ZW), Eurasian patent (AM, AZ, BY, KG, KZ, MD, RU, TJ, TM), European patent (AT, BE, CH, CY, DE, DK, ES, FI, FR, GB, GR, IE, IT, LU, MC, NL, PT, SE, TR), OAPI patent (BF, BJ, CF, CG, CI, CM, GA, GN, GQ, GW, ML, MR, NE, SN, TD, TG).

Published:

— *with international search report*

For two-letter codes and other abbreviations, refer to the "Guidance Notes on Codes and Abbreviations" appearing at the beginning of each regular issue of the PCT Gazette.

-1-

**EXPANDABLE MEDICAL DEVICE
FOR DELIVERY OF BENEFICIAL AGENT**

CROSS-REFERENCE TO RELATED APPLICATIONS

5 This application is a continuation-in-part of pending U.S. Application Serial No. 09/688,092, filed October 16, 2000, which is incorporated herein in its entirety. This application also claims priority to U.S. Provisional Application Serial No. 60/314,259, filed August 20, 2001 which is incorporated herein in its entirety.

BACKGROUND OF THE INVENTION

10 1. **Field of the Invention**

The present invention relates to tissue-supporting medical devices, and more particularly to expandable, non-removable devices that are implanted within a bodily lumen of a living animal or human to support the organ and maintain patency, and that can deliver a beneficial agent to the intervention site.

15 2. **Summary of the Related Art**

In the past, permanent or biodegradable devices have been developed for implantation within a body passageway to maintain patency of the passageway. These devices are typically introduced percutaneously, and transported transluminally until positioned at a desired location. These devices are then
20 expanded either mechanically, such as by the expansion of a mandrel or balloon positioned inside the device, or expand themselves by releasing stored energy upon actuation within the body. Once expanded within the lumen, these devices, called stents, become encapsulated within the body tissue and remain a permanent implant.

-2-

Known stent designs include monofilament wire coil stents (U.S. Pat. No. 4,969,458); welded metal cages (U.S. Pat. Nos. 4,733,665 and 4,776,337); and, most prominently, thin-walled metal cylinders with axial slots formed around the circumference (U.S. Pat. Nos. 4,733,665; 4,739,762; and 4,776,337). Known construction materials for use in stents include polymers, organic fabrics and biocompatible metals, such as, stainless steel, gold, silver, tantalum, titanium, and shape memory alloys such as Nitinol.

U.S. Pat. Nos. 4,733,665; 4,739,762; and 4,776,337 disclose expandable and deformable interluminal vascular grafts in the form of thin-walled tubular members with axial slots allowing the members to be expanded radially outwardly into contact with a body passageway. After insertion, the tubular members are mechanically expanded beyond their elastic limit and thus permanently fixed within the body. U.S. Pat. No. 5,545,210 discloses a thin-walled tubular stent geometrically similar to those discussed above, but constructed of a nickel-titanium shape memory alloy ("Nitinol"), which can be permanently fixed within the body without exceeding its elastic limit. All of these stents share a critical design property: in each design, the features that undergo permanent deformation during stent expansion are prismatic, i.e., the cross sections of these features remain constant or change very gradually along their entire active length. These prismatic structures are ideally suited to providing large amounts of elastic deformation before permanent deformation commences, which in turn leads to sub-optimal device performance in important properties including stent expansion force, stent recoil, strut element stability, stent securement on delivery catheters, and radiopacity.

U.S. Pat. No. 6,241,762, which is incorporated herein by reference in its entirety, discloses a non-prismatic stent design which remedies the above mentioned performance deficiencies of previous stents. In addition, preferred embodiments of this patent provide a stent with large, non-deforming strut and link

-3-

elements, which can contain holes without compromising the mechanical properties of the strut or link elements, or the device as a whole. Further, these holes may serve as large, protected reservoirs for delivering various beneficial agents to the device implantation site.

5 Of the many problems that may be addressed through stent-based local delivery of beneficial agents, one of the most important is restenosis. Restenosis is a major complication that can arise following vascular interventions such as angioplasty and the implantation of stents. Simply defined, restenosis is a wound healing process that reduces the vessel lumen diameter by extracellular matrix
10 deposition and vascular smooth muscle cell proliferation, and which may ultimately result in renarrowing or even reocclusion of the lumen. Despite the introduction of improved surgical techniques, devices and pharmaceutical agents, the overall restenosis rate is still reported in the range of 25% to 50% within six to twelve months after an angioplasty procedure. To treat this condition, additional
15 revascularization procedures are frequently required, thereby increasing trauma and risk to the patient.

 Some of the techniques under development to address the problem of restenosis include irradiation of the injury site and the use of conventional stents to deliver a variety of beneficial or pharmaceutical agents to the wall of the
20 traumatized vessel. In the latter case, a conventional stent is frequently surface-coated with a beneficial agent (often a drug-impregnated polymer) and implanted at the angioplasty site. Alternatively, an external drug-impregnated polymer sheath is mounted over the stent and co-deployed in the vessel.

 While acute outcomes from radiation therapies appeared promising
25 initially, long term beneficial outcomes have been limited to reduction in restenosis occurring within a previously implanted stent, so-called 'in-stent' restenosis. Radiation therapies have not been effective for preventing restenosis in *de novo* lesions. Polymer sheaths that span stent struts have also proven problematic in

human clinical trials due to the danger of blocking flow to branch arteries, incomplete apposition of stent struts to arterial walls and other problems. Unacceptably high levels of MACE (Major Adverse Cardiac Events that include death, heart attack, or the need for a repeat angioplasty or coronary artery bypass surgery) have resulted in early termination of clinical trials for sheath covered stents.

Conventional stents with surface coatings of various beneficial agents, by contrast, have shown promising early results. U.S. Pat. No. 5,716,981, for example, discloses a stent that is surface-coated with a composition comprising a polymer carrier and paclitaxel (a well-known compound that is commonly used in the treatment of cancerous tumors). The patent offers detailed descriptions of methods for coating stent surfaces, such as spraying and dipping, as well as the desired character of the coating itself: it should “coat the stent smoothly and evenly” and “provide a uniform, predictable, prolonged release of the anti-angiogenic factor.” Surface coatings, however, can provide little actual control over the release kinetics of beneficial agents. These coatings are necessarily very thin, typically 5 to 8 microns deep. The surface area of the stent, by comparison is very large, so that the entire volume of the beneficial agent has a very short diffusion path to discharge into the surrounding tissue.

Increasing the thickness of the surface coating has the beneficial effects of improving drug release kinetics including the ability to control drug release and to allow increased drug loading. However, the increased coating thickness results in increased overall thickness of the stent wall. This is undesirable for a number of reasons, including increased trauma to the vessel wall during implantation, reduced flow cross-section of the lumen after implantation, and increased vulnerability of the coating to mechanical failure or damage during expansion and implantation. Coating thickness is one of several factors that affect the release kinetics of the

-5-

beneficial agent, and limitations on thickness thereby limit the range of release rates, durations, and the like that can be achieved.

In addition to sub-optimal release profiles, there are further problems with surface coated stents. The fixed matrix polymer carriers frequently used in the device coatings typically retain approximately 30% of the beneficial agent in the coating indefinitely. Since these beneficial agents are frequently highly cytotoxic, sub-acute and chronic problems such as chronic inflammation, late thrombosis, and late or incomplete healing of the vessel wall may occur. Additionally, the carrier polymers themselves are often highly inflammatory to the tissue of the vessel wall. On the other hand, use of bio-degradable polymer carriers on stent surfaces can result in the creation of "virtual spaces" or voids between the stent and tissue of the vessel wall after the polymer carrier has degraded, which permits differential motion between the stent and adjacent tissue. Resulting problems include micro-abrasion and inflammation, stent drift, and failure to re-endothelialize the vessel wall.

Another significant problem is that expansion of the stent may stress the overlying polymeric coating causing the coating to plastically deform or even to rupture, which may therefore effect drug release kinetics or have other untoward effects. Further, expansion of such a coated stent in an atherosclerotic blood vessel will place circumferential shear forces on the polymeric coating, which may cause the coating to separate from the underlying stent surface. Such separation may again have untoward effects including embolization of coating fragments causing vascular obstruction.

SUMMARY OF THE INVENTION

In view of the drawbacks of the prior art, it would be advantageous to provide a stent capable of delivering a relatively large volume of a beneficial agent to a traumatized site in a vessel while avoiding the numerous problems associated

with surface coatings containing beneficial agents, without increasing the effective wall thickness of the stent, and without adversely impacting the mechanical expansion properties of the stent.

5 It would further be advantageous to have such a stent, which also significantly increases the available depth of the beneficial agent reservoir.

It would also be advantageous to have methods of loading various beneficial agents or combinations of beneficial agents into these deep reservoirs, which provided control over the temporal release kinetics of the agents.

10 In accordance with one aspect of the invention, an expandable medical device includes a plurality of elongated struts, said plurality of elongated struts joined together to form a substantially cylindrical device which is expandable from a cylinder having a first diameter to a cylinder having a second diameter, said plurality of struts each having a strut width in a circumferential direction and a strut thickness in a radial direction, at least one opening in at least one of the
15 plurality of struts, and at least one beneficial agent provided in the at least one opening in a plurality of layers.

In accordance with a further aspect of the present invention, an expandable medical device includes a plurality of elongated struts, said plurality of elongated struts joined together to form a substantially cylindrical device which is expandable
20 from a cylinder having a first diameter to a cylinder having a second diameter, said plurality of struts each having a strut width in a circumferential direction and a strut thickness in a radial direction, at least one opening in at least one of the plurality of struts, and at least one beneficial agent provided in the at least one opening. A shape of the beneficial agent is configured to achieve a desired agent
25 delivery profile.

In accordance with another aspect of the present invention, an expandable medical device for treating cardiac arrhythmias includes an expandable cylindrical device having a plurality of struts, a plurality of openings in the plurality of struts,

-7-

and a chemically ablative agent provided in the openings. The openings are configured to deliver the chemically ablative agent to tissue surrounding the expandable cylindrical device without permanently trapping any agent in the openings.

5 In accordance with an additional aspect of the present invention, an expandable medical device for treating cardiac arrhythmias includes an expandable cylindrical device having a plurality of struts, a plurality of openings in the plurality of struts, and an anti-arrhythmic drug and a non-biodegradable carrier provided in the openings. The openings are configured to deliver the anti-
10 arrhythmic drug to tissue surrounding the cylindrical device over an extended time period.

 In accordance with another aspect of the present invention, a method of forming an expandable medical device includes providing an expandable medical device with a plurality of struts, said plurality of struts joined together to form a
15 substantially cylindrical device which is expandable from a cylinder having a first diameter to a cylinder having a second diameter, forming at least one opening in at least one of the plurality of struts, and delivering at least one beneficial agent into in the at least one opening in a plurality of layers.

BRIEF DESCRIPTION OF THE DRAWINGS

20 The invention will now be described in greater detail with reference to the preferred embodiments illustrated in the accompanying drawings, in which like elements bear like reference numerals, and wherein:

 FIG. 1 is a perspective view of a tissue supporting device in accordance with a first preferred embodiment of the present invention;

25 FIG. 2 is an enlarged side view of a portion of the device of FIG. 1;

 FIG. 3 is an enlarged side view of a tissue supporting device in accordance with a further preferred embodiment of the present invention;

FIG. 4 is an enlarged side view of a portion of the stent shown in FIG. 3;

FIG. 5 is an enlarged cross section of an opening;

FIG. 6 is an enlarged cross section of an opening illustrating beneficial agent loaded into the opening;

5 FIG. 7 is an enlarged cross section of an opening illustrating a beneficial agent loaded into the opening and a thin coating of a beneficial agent;

FIG. 8 is an enlarged cross section of an opening illustrating a beneficial agent loaded into the opening and thin coatings of different beneficial agents on different surfaces of the device;

10 FIG. 9 is an enlarged cross section of an opening illustrating a beneficial agent provided in a plurality of layers;

FIG. 10 is an enlarged cross section of an opening illustrating a beneficial agent and a barrier layer loaded into the opening in layers;

15 FIG. 11A is an enlarged cross section of an opening illustrating a beneficial agent, a biodegradable carrier, and a barrier layer loaded into the opening in layers;

FIG. 11B is a graph of the release kinetics of the device of FIG. 11A;

FIG. 12 is an enlarged cross section of an opening illustrating different beneficial agents, carrier, and barrier layers loaded into the opening;

20 FIG. 13 is an enlarged cross section of an opening illustrating a beneficial agent loaded into the opening in layers of different concentrations;

FIG. 14 is an enlarged cross section of an opening illustrating a beneficial agent loaded into the opening in layers of microspheres of different sizes;

25 FIG. 15A is an enlarged cross section of a tapered opening illustrating a beneficial agent loaded into the opening;

FIG. 15B is an enlarged cross section of the tapered opening of FIG. 15A with the beneficial agent partially degraded;

FIG. 15C is a graph of the release kinetics of the device of FIGS. 15A and 15B;

FIG. 16A is an enlarged cross section of an opening illustrating a beneficial agent loaded into the opening in a shape configured to achieve a desired agent
5 delivery profile;

FIG. 16B is an enlarged cross section of the opening of FIG. 16A with the beneficial agent partially degraded;

FIG. 16C is a graph of the release kinetics of the device of FIGS. 16A and 16B;

10 FIG. 17A is an enlarged cross section of an opening illustrating the beneficial agent loaded into the opening and a spherical shape;

FIG. 17B is a graph of the release kinetics of the device of FIG. 17A;

FIG. 18A is an enlarged cross section of an opening illustrating a plurality of beneficial agent layers and a barrier layer with an opening for achieving a
15 desired agent delivery profile;

FIG. 18B is an enlarged cross section of the opening of FIG. 18A with the agent layers beginning to degraded;

FIG. 18C is an enlarged cross section of the opening of FIG. 18A with the agent layers further degraded; and

20 FIG. 19 is an enlarged cross section of an opening illustrating a plurality of cylindrical beneficial agent layers.

DETAILED DESCRIPTION OF THE PREFERRED EMBODIMENTS

Referring to FIGS. 1 and 2, a tissue supporting device in accordance with one preferred embodiment of the present invention is shown generally by reference
25 numeral 10. The tissue supporting device 10 includes a plurality of cylindrical tubes 12 connected by S-shaped bridging elements 14. The bridging elements 14 allow the tissue supporting device to bend axially when passing through the

-10-

tortuous path of the vasculature to the deployment site and allow the device to bend when necessary to match the curvature of a vessel wall to be supported. Each of the cylindrical tubes 12 has a plurality of axial slots 16 extending from an end surface of the cylindrical tube toward an opposite end surface.

5 Formed between the slots 16 is a network of axial struts 18 and links 22. The struts 18 and links 22 are provided with openings for receiving and delivering a beneficial agent. As will be described below with respect to FIGS. 9-17, the beneficial agent is loaded into the openings in layers or other configurations which provide control over the temporal release kinetics of the agent.

10 Each individual strut 18 is preferably linked to the rest of the structure through a pair of reduced sections 20, one at each end, which act as stress/strain concentration features. The reduced sections 20 of the struts function as hinges in the cylindrical structure. Since the stress/strain concentration features are designed to operate into the plastic deformation range of generally ductile
15 materials, they are referred to as ductile hinges 20. The ductile hinges 20 are described in further detail in U.S. Pat. No. 6,241,762, which has been incorporated herein by reference.

20 With reference to the drawings and the discussion, the *width* of any feature is defined as its dimension in the circumferential direction of the cylinder. The *length* of any feature is defined as its dimension in the axial direction of the cylinder. The *thickness* of any feature is defined as the wall thickness of the cylinder.

25 The presence of the ductile hinges 20 allows all of the remaining features in the tissue supporting device to be increased in width or the circumferentially oriented component of their respective rectangular moments of inertia - thus greatly increasing the strength and rigidity of these features. The net result is that elastic, and then plastic deformation commence and propagate in the ductile hinges 20 before other structural elements of the device undergo any significant elastic

-11-

deformation. The force required to expand the tissue supporting device 10 becomes a function of the geometry of the ductile hinges 20, rather than the device structure as a whole, and arbitrarily small expansion forces can be specified by changing hinge geometry for virtually any material wall thickness. The ability to
5 increase the width and thickness of the struts 18 and links 22 provides additional area and depth for the beneficial agent receiving openings.

In the preferred embodiment of FIGS. 1 and 2, it is desirable to increase the width of the individual struts 18 between the ductile hinges 20 to the maximum width that is geometrically possible for a given diameter and a given number of
10 struts arrayed around that diameter. The only geometric limitation on strut width is the minimum practical width of the slots 16 which is about 0.002 inches (0.0508 mm) for laser machining. Lateral stiffness of the struts 18 increases as the cube of strut width, so that relatively small increases in strut width significantly increase strut stiffness. The net result of inserting ductile hinges 20 and increasing strut
15 width is that the struts 18 no longer act as flexible leaf springs, but act as essentially rigid beams between the ductile hinges. All radial expansion or compression of the cylindrical tissue supporting device 10 is accommodated by mechanical strain in the hinge features 20, and yield in the hinge commences at very small overall radial expansion or compression.

The ductile hinge 20 illustrated in FIGS. 1 and 2 is exemplary of a
20 preferred structure that will function as a stress/strain concentrator. Many other stress/strain concentrator configurations may also be used as the ductile hinges in the present invention, as shown and described by way of example in U.S. Pat. No. 6,241,762. The geometric details of the stress/strain concentration features or
25 ductile hinges 20 can be varied greatly to tailor the exact mechanical expansion properties to those required in a specific application.

Although a tissue supporting device configuration has been illustrated in FIG. 1 which includes ductile hinges, it should be understood that the beneficial

-12-

agent may be contained in openings in stents having a variety of designs including the designs illustrated in U.S. Provisional Patent Application Serial No. 60/314,360, filed on August 20, 2001 and U.S. Patent Application Serial No. 09/948,987, filed on September 7, 2001 (Attorney Docket No. 032304-033),
5 which are incorporated herein by reference. The present invention incorporating beneficial agent openings may also be used with other known stent designs.

As shown in FIGS. 1-4, at least one and more preferably a series of openings 24 are formed by laser drilling or any other means known to one skilled in the art at intervals along the neutral axis of the struts 18. Similarly, at least one
10 and preferably a series of openings 26 are formed at selected locations in the links 22. Although the use of openings 24 and 26 in both the struts 18 and links 22 is preferred, it should be clear to one skilled in the art that openings could be formed in only one of the struts and links. Openings may also be formed in the bridging elements 14. In the embodiment of FIGS. 1 and 2, the openings 24, 26 are
15 circular in nature and form cylindrical holes extending through the width of the tissue supporting device 10. It should be apparent to one skilled in the art, however, that openings of any geometrical shape or configuration could of course be used without departing from the scope of the present invention. In addition, openings having a depth less than the thickness of the device may also be used.

20 The behavior of the struts 18 in bending is analogous to the behavior of an I-beam or truss. The outer edge elements 32 of the struts 18, shown in FIG. 2, correspond to the I-beam flange and carry the tensile and compressive stresses, whereas the inner elements 34 of the struts 18 correspond to the web of an I-beam which carries the shear and helps to prevent buckling and wrinkling of the faces.
25 Since most of the bending load is carried by the outer edge elements 32 of the struts 18, a concentration of as much material as possible away from the neutral axis results in the most efficient sections for resisting strut flexure. As a result, material can be judiciously removed along the axis of the strut so as to form

-13-

openings 24, 26 without adversely impacting the strength and rigidity of the strut. Since the struts 18 and links 22 thus formed remain essentially rigid during stent expansion, the openings 24, 26 are also non-deforming.

5 The openings 24, 26 in the struts 18 may promote the healing of the intervention site by promoting regrowth of the endothelial cells. By providing the openings 24, 26 in the struts, 18, the cross section of the strut is effectively reduced without decreasing the strength and integrity of the strut, as described above. As a result, the overall distance across which endothelial cell regrowth must occur is also reduced to approximately 0.0025 - 0.0035 inches, which is
10 approximately one-half of the thickness of a conventional stent. It is further believed that during insertion of the expandable medical device, cells from the endothelial layer may be scraped from the inner wall of the vessel by the openings 24, 26 and remain therein after implantation. The presence of such endothelial cells would thus provide a basis for the healing of the vessel wall.

15 The openings 24, 26 are loaded with an agent, most preferably a beneficial agent, for delivery to the vessel wall which the tissue supporting device 10 is supporting.

The terms "agent" and "beneficial agent" as used herein are intended to have their broadest possible interpretation and are used to include any therapeutic
20 agent or drug, as well as inactive agents such as barrier layers or carrier layers. The terms "drug" and "therapeutic agent" are used interchangeably to refer to any therapeutically active substance that is delivered to a bodily conduit of a living being to produce a desired, usually beneficial, effect. The present invention is particularly well suited for the delivery of antiproliferatives (anti-restenosis agents)
25 such as paclitaxel and rapamycin for example, and antithrombins such as heparin, for example.

The beneficial agents used in the present invention include classical small molecular weight therapeutic agents commonly referred to as drugs including all

-14-

classes of action as exemplified by, but not limited to: antiproliferatives, antithrombins, antiplatelet, antilipid, anti-inflammatory, and anti-angiogenic, vitamins, ACE inhibitors, vasoactive substances, antimetabolites, metallo-proteinase inhibitors, NO donors, estradiols, anti-sclerosing agents, alone or in combination.

5 Beneficial agent also includes larger molecular weight substances with drug like effects on target tissue sometimes called biologic agents including but not limited to: peptides, lipids, protein drugs, enzymes, oligonucleotides, ribozymes, genetic material, prions, virus, bacteria, and eucaryotic cells such as endothelial cells, monocyte/macrophages or vascular smooth muscle cells to name but a few
10 examples. Other beneficial agents may include but not be limited to physical agents such as microspheres, microbubbles, liposomes, radioactive isotopes, or agents activated by some other form of energy such as light or ultrasonic energy, or by other circulating molecules that can be systemically administered.

The embodiment of the invention shown in FIGS. 1 and 2 can be further
15 refined by using Finite Element Analysis and other techniques to optimize the deployment of the beneficial agent within the openings of the struts and links. Basically, the shape and location of the openings 24, 26 can be modified to maximize the volume of the voids while preserving the relatively high strength and rigidity of the struts 18 with respect to the ductile hinges 20.

20 FIG. 3 illustrates a further preferred embodiment of the present invention, wherein like reference numerals have been used to indicate like components. The tissue supporting device 100 includes a plurality of cylindrical tubes 12 connected by S-shaped bridging elements 14. Each of the cylindrical tubes 12 has a plurality of axial slots 16 extending from an end surface of the cylindrical tube toward an
25 opposite end surface. Formed between the slots 16 is a network of axial struts 18 and links 22. Each individual strut 18 is linked to the rest of the structure through a pair of ductile hinges 20, one at each end, which act as stress/strain

-15-

concentration features. Each of the ductile hinges 20 is formed between an arc surface 28 and a concave notch surface 29.

At intervals along the neutral axis of the struts 18, at least one and more preferably a series of openings 24' are formed by laser drilling or any other means known to one skilled in the art. Similarly, at least one and preferably a series of openings 26' are formed at selected locations in the links 22. Although the use of openings 24', 26' in both the struts 18 and links 22 is preferred, it should be clear to one skilled in the art that openings could be formed in only one of the struts and links. In the illustrated embodiment, the openings 24' in the struts 18 are generally rectangular whereas the openings 26' in the links 22 are polygonal. It should be apparent to one skilled in the art, however, that openings of any geometrical shape or configuration could of course be used, and that the shape of openings 24, 24' may be the same or different from the shape of openings 26, 26', without departing from the scope of the present invention. As described in detail above, the openings 24', 26' may be loaded with an agent, most preferably a beneficial agent, for delivery to the vessel in which the tissue support device 100 is deployed. Although the openings 24', 26' are preferably through openings, they may also be recesses extending only partially through the thickness of the struts and links.

The relatively large, protected openings 24, 24', 26, 26', as described above, make the expandable medical device of the present invention particularly suitable for delivering agents having more esoteric larger molecules or genetic or cellular agents, such as, for example, protein drugs, enzymes, antibodies, antisense oligonucleotides, ribozymes, gene/vector constructs, and cells (including but not limited to cultures of a patient's own endothelial cells). Many of these types of agents are biodegradable or fragile, have a very short or no shelf life, must be prepared at the time of use, or cannot be pre-loaded into delivery devices such as stents during the manufacture thereof for some other reason. The large

-16-

through-openings in the expandable device of the present invention form protected areas or receptors to facilitate the loading of such an agent either at the time of use or prior to use, and to protect the agent from abrasion and extrusion during delivery and implantation.

5 The volume of beneficial agent that can be delivered using through openings is about 3 to 10 times greater than the volume of a 5 micron coating covering a stent with the same stent/vessel wall coverage ratio. This much larger beneficial agent capacity provides several advantages. The larger capacity can be used to deliver multi-drug combinations, each with independent release profiles,
10 for improved efficacy. Also, larger capacity can be used to provide larger quantities of less aggressive drugs and to achieve clinical efficacy without the undesirable side-effects of more potent drugs, such as retarded healing of the endothelial layer.

 Through openings also decrease the surface area of the beneficial agent
15 bearing compounds to which the vessel wall surface is exposed. For typical devices with beneficial agent openings, this exposure decreases by a factors ranging from about 6:1 to 8:1, by comparison with surface coated stents. This dramatically reduces the exposure of vessel wall tissue to polymer carriers and other agents that can cause inflammation, while simultaneously increasing the
20 quantity of beneficial agent delivered, and improving control of release kinetics.

 FIG. 4 shows an enlarged view of one of the struts 18 of device 100 disposed between a pair of ductile hinges 20 having a plurality of openings 24'. FIG. 5 illustrates a cross section of one of the openings 24' shown in FIG. 4. FIG. 6 illustrates the same cross section when a beneficial agent 36 has been
25 loaded into the opening 24' of the strut 18. Optionally, after loading the opening 24' and/or the opening 26' with a beneficial agent 36, the entire exterior surface of the stent can be coated with a thin layer of a beneficial agent 38, which may be the same as or different from the beneficial agent 36, as schematically shown in FIG.

7. Still further, another variation of the present invention would coat the outwardly facing surfaces of the stent with a first beneficial agent 38 while coating the inwardly facing surfaces of the stent with a different beneficial agent 39, as illustrated in FIG. 8. The inwardly facing surface of the stent would be defined as
5 at least the surface of the stent which, after expansion, forms the inner passage of the vessel. The outwardly facing surface of the stent would be defined as at least the surface of the stent which, after expansion, is in contact with and directly supports the inner wall of the vessel. The beneficial agent 39 coated on the inner surfaces may be a barrier layer which prevents the beneficial agent 36 from
10 passing into the lumen of the blood vessel and being washed away in the blood stream.

FIG. 9 shows a cross section of an opening 24 in which one or more beneficial agents have been loaded into the opening 24 in discrete layers 50. One method of creating such layers is to deliver a solution comprising beneficial agent,
15 polymer carrier, and a solvent into the opening and evaporating the solvent to create a thin solid layer of beneficial agent in the carrier. Other methods of delivering the beneficial agent can also be used to create layers. According to another method for creating layers, a beneficial agent may be loaded into the openings alone if the agent is structurally viable without the need for a carrier.
20 The process can then be repeated until each opening is partially or entirely filled.

In a typical embodiment, the total depth of the opening 24 is about 125 to about 140 microns, and the typical layer thickness would be about 2 to about 50 microns, preferably about 12 microns. Each typical layer is thus individually about twice as thick as the typical coating applied to surface-coated stents. There
25 would be at least two and preferably about ten to twelve such layers in a typical opening, with a total beneficial agent thickness about 25 to 28 times greater than a typical surface coating. According to one preferred embodiment of the present

-18-

invention, the openings have an area of at least 5×10^{-6} square inches, and preferably at least 7×10^{-6} square inches.

5 Since each layer is created independently, individual chemical compositions and pharmacokinetic properties can be imparted to each layer. Numerous useful arrangements of such layers can be formed, some of which will be described below. Each of the layers may include one or more agents in the same or different proportions from layer to layer. The layers may be solid, porous, or filled with other drugs or excipients.

10 FIG. 9 shows the simplest arrangement of layers including identical layers 50 that together form a uniform, homogeneous distribution of beneficial agent. If the carrier polymer were comprised of a biodegradable material, then erosion of the beneficial agent containing carrier would occur on both faces of the opening at the same time, and beneficial agent would be released at an approximately linear rate over time corresponding to the erosion rate of the carrier. This linear or
15 constant release rate is referred to as a zero order delivery profile. Use of biodegradable carriers in combination with through openings is especially useful, to guarantee 100% discharge of the beneficial agent within a desired time without creating virtual spaces or voids between the radially outermost surface of the stent and tissue of the vessel wall. When the biodegradable material in the through
20 openings is removed, the openings may provide a communication between the strut-covered vessel wall and the blood stream. Such communication may accelerate vessel healing and allow the ingrowth of cells and extracellular components that more thoroughly lock the stent in contact with the vessel wall. Alternatively, some through-openings may be loaded with beneficial agent while
25 others are left unloaded. The unloaded holes could provide an immediate nidus for the ingrowth of cells and extracellular components to lock the stent into place, while loaded openings dispense the beneficial agent.

The advantage of complete erosion using the through openings over surface coated stents opens up new possibilities for stent-based therapies. In the treatment of cardiac arrhythmias, such as atrial fibrillation both sustained and paroxysmal, sustained ventricular tachycardia, super ventricular tachycardia including reentrant and ectopic, and sinus tachycardia, a number of techniques under development attempt to ablate tissue in the pulmonary veins or some other critical location using various energy sources, e.g. microwaves, generally referred to as radio-frequency ablation, to create a barrier to the propagation of undesired electrical signals in the form of scar tissue. These techniques have proven difficult to control accurately.

5 A stent based therapy using through openings, biodegradable carriers, and associated techniques described herein could be used to deliver a *chemically* ablative agent in a specific, precise pattern to a specific area for treatment of atrial fibrillation, while guaranteeing that none of the inherently cytotoxic ablating agent could be permanently trapped in contact with the tissue of the vessel wall.

15 If, on the other hand, the goal of a particular therapy is to provide a long term effect, beneficial agents located in openings provide an equally dramatic advantage over surface coated devices. In this case, a composition comprising a beneficial agent and a non-biodegradable carrier would be loaded into the through openings, preferably in combination with a diffusion barrier layer as described

20 below. To continue the cardiac arrhythmias example, it might be desirable to introduce a long-term anti-arrhythmic drug near the ostia of the pulmonary veins or some other critical location. The transient diffusion behavior of a beneficial agent through a non-biodegradable carrier matrix can be generally described by Fick's second law:

$$\frac{\partial C_x}{\partial t} = \frac{\partial}{\partial x} \left[D \frac{\partial C_x}{\partial x} \right]$$

-20-

Where C is the concentration of beneficial agent at cross section x, x is either the thickness of a surface coating or depth of a through opening, D is the diffusion coefficient and t is time. The solution of this partial differential equation for a through opening with a barrier layer will have the form of a *normalized probability integral* or *Gaussian Error Function*, the argument of which will contain the term

$$\frac{x}{2\sqrt{Dt}}$$

To compare the time intervals over which a given level of therapy can be sustained for surface coatings vs. through openings, we can use Fick's Second Law to compare the times required to achieve equal concentrations at the most inward surfaces of the coating and opening respectively, i.e. the values of x and t for which the arguments of the Error Function are equal:

$$\frac{x_1}{2\sqrt{Dt_1}} = \frac{x_2}{2\sqrt{Dt_2}} \Rightarrow \frac{x_1^2}{x_2^2} = \frac{t_1}{t_2}$$

The ratio of diffusion times to achieve comparable concentrations thus varies as the square of the ratio of depths. A typical opening depth is about 140 microns while a typical coating thickness is about 5 micron; the square of this ratio is 784, meaning that the effective duration of therapy for through openings is potentially almost three orders of magnitude greater for through openings than for surface coatings of the same composition. The inherent non-linearity of such release profiles can in part be compensated for in the case of through openings, but not in thin surface coatings, by varying the beneficial agent concentration of layers in a through opening as described below. It will be recalled that, in addition to this great advantage in beneficial agent delivery *duration*, through openings are capable

of delivering a 3 to 10 times greater *quantity* of beneficial agent, providing a decisive overall advantage in sustained therapies. The diffusion example above illustrates the general relationship between depth and diffusion time that is characteristic of a wider class of solid state transport mechanisms.

5 Beneficial agent that is released to the radially innermost or inwardly facing surface known as the lumen facing surface of an expanded device may be rapidly carried away from the targeted area, for example by the bloodstream, and thus lost. Up to half of the total agent loaded in such situations may have no therapeutic effect due to being carried away by the bloodstream. This is probably
10 the case for all surface coated stents as well as the through opening device of FIG. 9.

FIG. 10 shows a device in which the first layer 52 is loaded into a through opening 24 such that the inner surface of the layer is substantially co-planar with the inwardly facing surface 54 of the cylindrical device. The first layer 52 is
15 comprised of a material called a barrier material which blocks or retards biodegradation of subsequent layers in the inwardly facing direction toward the vessel lumen, and/or blocks or retards diffusion of the beneficial agent in that direction. Biodegradation of other layers or beneficial agent diffusion can then proceed only in the direction of the outwardly facing surface 56 of the device,
20 which is in direct contact with the targeted tissue of the vessel wall. The barrier layer 52 may also function to prevent hydration of inner layers of beneficial agent and thus prevent swelling of the inner layers when such layers are formed of hygroscopic materials. The barrier layer 52 may further be comprised of a biodegradable material that degrades at a much slower rate than the biodegradable
25 material in the other layers, so that the opening will eventually be entirely cleared. Providing a barrier layer 52 in the most inwardly facing surface of a through-opening thus guarantees that the entire load of beneficial agent is delivered to the target area in the vessel wall. It should be noted that providing a barrier layer on

-22-

the inwardly facing surface of a surface-coated stent without openings *does not* have the same effect; since the beneficial agent in such a coating cannot migrate through the metal stent to the target area on the outer surface, it simply remains trapped on the inner diameter of the device, again having no therapeutic effect.

5 Barrier layers can be used to control beneficial agent release kinetics in more sophisticated ways. A barrier layer 52 with a pre-determined degradation time could be used to deliberately terminate the beneficial agent therapy at a pre-determined time, by exposing the underlying layers to more rapid bio-degradation from both sides. Barrier layers can also be formulated to be activated by a
10 separate, systemically applied agent. Such systemically applied agent could change the porosity of the barrier layer and/or change the rate of bio-degradation of the barrier layer or the bulk beneficial agent carrier. In each case, release of the beneficial agent could be activated by the physician at will by delivery of the systemically applied agent. A further embodiment of physician activated therapy
15 would utilize a beneficial agent encapsulated in micro-bubbles and loaded into device openings. Application of ultrasonic energy from an exterior of the body could be used to collapse the bubbles at a desired time, releasing the beneficial agent to diffuse to the outwardly facing surface of the reservoirs. These activation techniques can be used in conjunction with the release kinetics control techniques
20 described herein to achieve a desired drug release profile that can be activated and/or terminated at selectable points in time.

 FIG. 11A shows an arrangement of layers provided in a through opening in which layers 50 of a beneficial agent in a biodegradable carrier material, are alternated with layers 58 of the biodegradable carrier material alone, with no
25 active agent loaded, and a barrier layer 52 is provided at the inwardly facing surface. As shown in the release kinetics plot of FIG. 11B, such an arrangement releases beneficial agent in three programmable bursts or waves achieving a stepped or pulsatile delivery profile. The use of carrier material layers without

-23-

active agent creates the potential for synchronization of drug release with cellular biochemical processes for enhanced efficacy.

Alternatively, different layers could be comprised of different beneficial agents altogether, creating the ability to release different beneficial agents at
5 different points in time, as shown in FIG. 12. For example, in FIG. 12, a layer
60 of anti-thrombotic agent could be deposited at the inwardly facing surface of the
stent, followed by a barrier layer 52 and alternating layers of anti-proliferatives 62
and anti-inflammatories 64. This configuration could provide an initial release of
anti-thrombotic agent into the bloodstream while simultaneously providing a
10 gradual release of anti-proliferatives interspersed with programmed bursts of anti-
inflammatory agents to the vessel wall. The configurations of these layers can be
designed to achieve the agent delivery bursts at particular points in time
coordinated with the body's various natural healing processes.

A further alternative is illustrated in FIG. 13. Here the concentration of
15 the same beneficial agent is varied from layer to layer, creating the ability to
generate release profiles of arbitrary shape. Progressively increasing the
concentration of agent in the layers 66 with increasing distance from the outwardly
facing surface 56, for example, produces a release profile with a progressively
increasing release rate, which would be impossible to produce in a thin surface
20 coating.

Another general method for controlling beneficial agent release kinetics is
to alter the beneficial agent flux by changing the surface area of drug elution
sources as a function of time. This follows from Fick's First Law, which states
that the instantaneous molecular flux is proportional to surface area, among other
25 factors:

$$J = D \frac{\partial C}{\partial x} \Rightarrow \frac{\partial N}{\partial t} = AD \frac{\partial c}{\partial x}$$

-24-

Where $\partial N/\partial t$ is the number of molecules per unit time, A is the instantaneous drug eluting surface area, D is the diffusivity, and C is the concentration. The drug eluting surface area of a surface coated stent is simply the surface area of the stent itself. Since this area is fixed, this method of controlling release kinetics is
5 not available to surface coated devices. Through openings, however, present several possibilities for varying surface area as a function of time.

In the embodiment of FIG. 14, beneficial agent is provided in the openings
24 in the form of microspheres, particles or the like. Individual layers 70 can then be created that contain these particles. Further, the particle size can be varied
10 from layer to layer. For a given layer volume, smaller particle sizes increase the total particle surface area in that layer, which has the effect of varying the total surface area of the beneficial agent from layer to layer. Since the flux of drug molecules is proportional to surface area, the total drug flux can be adjusted from layer to layer by changing the particle size, and the net effect is control of release
15 kinetics by varying particle sizes within layers.

A second general method for varying drug eluting surface area as a function of time is to change the shape or cross-sectional area of the drug-bearing element along the axis of the opening. FIG. 15A shows an opening 70 having a conical shape cut into the material of the stent itself. The opening 70 may then be
20 filled with beneficial agent 72 in layers as described above or in another manner. In this embodiment, a barrier layer 74 may be provided on the inwardly facing side of the opening 70 to prevent the beneficial agent 72 from passing into the blood stream. In this example, the drug eluting surface area A_t would continuously diminish (from FIG. 15A to FIG. 15B) as the bio-degradable carrier
25 material erodes, yielding the elution pattern of FIG. 15C.

FIG. 16A shows a simple cylindrical through-opening 80 in which a preformed, inverted cone 82 of beneficial agent has been inserted. The rest of the through opening 80 is then back-filled with a biodegradable substance 84 with a

-25-

much slower rate of degradation or a non-biodegradable substance, and the inwardly facing opening of the through opening is sealed with a barrier layer 86. This technique yields the opposite behavior to the previous example. The drug-eluting surface area A_t continuously increases with time between FIG. 16A and 5 16B, yielding the elution pattern of FIG. 16C.

The changing cross section openings 70 of FIG. 15A and the non-biodegradable backfilling techniques of FIG. 16A may be combined with any of the layered agent embodiments of FIGS. 9-14 to achieve desired release profiles. For example, the embodiment of FIG. 15A may use the varying agent 10 concentration layers of FIG. 13 to more accurately tailor a release curve to a desired profile.

The process of preforming the beneficial agent plug 82 to a special shape, inserting in a through opening, and back-filling with a second material can yield more complex release kinetics as well. FIG. 17A shows a through opening 90 in 15 which a spherical beneficial agent plug 92 has been inserted. The resulting biodegradation of the sphere, in which the cross sectional surface area varies as a sinusoidal function of depth, produces a flux density which is roughly a sinusoidal function of time, FIG. 17B. Other results are of course possible with other profiles, but none of these more complex behaviors could be generated in a thin, 20 fixed-area surface coating.

An alternative embodiment of FIGS. 18A-18C use a barrier layer 52' with an opening 96 to achieve the increasing agent release profile of FIG. 16C. As shown in FIG. 18A, the opening 24 is provided with an inner barrier layer 52 and multiple beneficial agent layers 50 as in the embodiment of FIG. 10. An 25 additional outer barrier layer 52' is provided with a small hole 96 for delivery of the agent to the vessel wall. As shown in FIGS. 18B and 18C, the beneficial agent containing layers 50 degrade in a hemispherical pattern resulting in

-26-

increasing surface area for agent delivery over time and thus, an increasing agent release profile.

FIG. 19 illustrates an alternative embodiment in which an opening in the tissue supporting device is loaded with cylindrical layers of beneficial agent.

5 According to one method of forming the device of FIG. 19, the entire device is coated with sequential layers 100, 102, 104, 106 of beneficial agent. The interior surface 54 and exterior surface 56 of the device are then stripped to remove the beneficial agent on these surfaces leaving the cylindrical layers of beneficial agent in the openings. In this embodiment, a central opening remains after the coating
10 layers have been deposited which allows communication between the outer surface 56 and inner surface 54 of the tissue supporting device.

In the embodiment of FIG. 19, the cylindrical layers are eroded sequentially. This can be used for pulsatile delivery of different beneficial agents, delivery of different concentrations of beneficial agents, or delivery of the same
15 agent. As shown in FIG. 19, the ends of the cylindrical layers 100, 102, 104, 106 are exposed. This results in a low level of erosion of the underlying layers during erosion of an exposed layer. Alternatively, the ends of the cylindrical layers may be covered by a barrier layer to prevent this low level continuous erosion. Erosion rates of the cylindrical layers may be further controlled by contouring the surfaces
20 of the layers. For example, a ribbed or star-shaped pattern may be provided on the radially inner layers to provide a uniform surface area or uniform erosion rate between the radially inner layers and the radially outer layers. Contouring of the surfaces of layers may also be used in other embodiments to provide an additional variable for controlling the erosion rates.

25 While the invention has been described in detail with reference to the preferred embodiments thereof, it will be apparent to one skilled in the art that various changes and modifications can be made and equivalents employed, without departing from the present invention.

-27-

Claims:

1. An expandable medical device comprising:
a plurality of elongated struts, said plurality of elongated struts
joined together to form a substantially cylindrical device which is expandable from
5 a cylinder having a first diameter to a cylinder having a second diameter, said
plurality of struts each having a strut width in a circumferential direction and a
strut thickness in a radial direction;
at least one opening in at least one of the plurality of struts; and
at least one beneficial agent provided in the at least one opening in a
10 plurality of layers.
2. The expandable medical device according to Claim 1, wherein the
at least one opening extends at least partially through the thickness of said strut.
3. The expandable medical device according to Claim 1, wherein said
at least one opening comprises a plurality of openings.
- 15 4. The expandable medical device according to Claim 1, wherein said
at least one opening extends through the thickness of said at least one strut, so as
to thereby define a through opening.
5. The expandable medical device according to Claim 1, wherein said
at least one opening has a depth less than the thickness of said at least one strut, so
20 as to thereby define a recess.
6. The expandable medical device according to Claim 1, wherein said
plurality of beneficial agent layers include layers of different chemical
compositions.

-28-

7. The expandable medical device according to Claim 6, wherein said different chemical compositions include a barrier composition and an active beneficial agent composition.

5 8. The expandable medical device according to Claim 7, wherein said barrier composition has an opening formed therein.

9. The expandable medical device according to Claim 6, wherein said different chemical compositions include different active beneficial agents.

10 10. The expandable medical device according to Claim 9, wherein said different active beneficial agents include anti-thrombotic agents and anti-proliferative agents.

11. The expandable medical device according to Claim 1, wherein said plurality of beneficial agent layers include layers of beneficial agent having the same chemical composition in different concentrations.

15 12. The expandable medical device according to Claim 1, wherein said plurality of beneficial agent layers include a barrier layer at a radially innermost location in the at least one opening.

13. The expandable medical device according to Claim 1, wherein the plurality of beneficial agent layers include a barrier layer between two active beneficial agent layers.

20 14. The expandable medical device according to Claim 1, wherein said beneficial agent is formulated to be activated by a systemically applied agent.

-29-

15. The expandable medical device according to Claim 14, wherein said systemically applied agent is ultrasound.
16. The expandable medical device according to Claim 14, wherein said systemically applied agent is a chemical agent.
- 5 17. The expandable medical device according to Claim 1, wherein the beneficial agent is contained in microspheres.
18. The expandable medical device according to Claim 17, wherein said plurality of layers include layers with microspheres of different sizes.
- 10 19. The expandable medical device according to Claim 1, wherein the opening has a shape configured to vary the release rate of a beneficial agent over time.
20. The expandable medical device according to Claim 1, wherein the beneficial agent is provided in the opening in a biodegradable carrier.
- 15 21. The expandable medical device according to Claim 1, wherein the beneficial agent is configured to diffuse from a carrier in the opening.
22. The expandable medical device according to Claim 1, wherein the beneficial agent layers include a bio-degradable barrier layer configured to terminate a therapy at a predetermined time.
- 20 23. The expandable medical device according to Claim 1, wherein the beneficial agent is paclitaxel, or an analogue or derivative thereof.

-30-

24. The expandable medical device according to Claim 1, wherein the beneficial agent is rapamycin, or an analogue or derivative thereof.

25. The expandable medical device according to Claim 1, wherein the at least one opening comprises a plurality of openings containing the beneficial agent and a plurality of openings remaining open for anchoring purposes.

26. The expandable medical device according to Claim 1, wherein the plurality of beneficial agent layers are substantially cylindrical.

27. An expandable medical device comprising:
a plurality of elongated struts, said plurality of elongated struts joined together to form a substantially cylindrical device which is expandable from a cylinder having a first diameter to a cylinder having a second diameter, said plurality of struts each having a strut width in a circumferential direction and a strut thickness in a radial direction;
at least one opening in at least one of the plurality of struts; and
at least one beneficial agent provided in the at least one opening, wherein a shape of the beneficial agent is configured to achieve a desired agent delivery profile.

28. The expandable medical device according to Claim 27, wherein said at least one opening comprises a plurality of openings.

29. The expandable medical device according to Claim 27, wherein said at least one opening extends through the thickness of said at least one strut, so as to thereby define a through-opening.

-31-

30. The expandable medical device according to Claim 27, wherein said at least one opening has a depth less than the thickness of said at least one strut, so as to thereby define a recess.

5 31. The expandable medical device according to Claim 27, wherein the at least one beneficial agent is a substantially conical plug configured to achieve an continuously varying agent delivery profile.

32. The expandable medical device according to Claim 27, wherein the at least one beneficial agent is a substantially spherical plug configured to achieve a substantially sinusoidally varying agent delivery profile.

10 33. The expandable medical device according to Claim 27, wherein the at least one beneficial agent is a plug and a filling material surrounds the plug in the opening.

15 34. The expandable medical device according to Claim 27, wherein the opening is configured in a non-cylindrical shape to achieve the desired agent delivery profile.

35. The expandable medical device according to Claim 27, wherein the beneficial agent is paclitaxel, or an analogue or derivative thereof.

36. The expandable medical device according to Claim 27, wherein the beneficial agent is rapamycin, or an analogue or derivative thereof.

-32-

37. The expandable medical device according to Claim 27, wherein the at least one opening comprises a plurality of openings containing the beneficial agent and a plurality of openings remaining open for anchoring purposes.

5 38. An expandable medical device for treating cardiac arrhythmias, the device comprising:

an expandable cylindrical device having a plurality of struts;
a plurality of openings in the plurality of struts; and
a chemically ablative agent provided in the openings, wherein the openings are configured to deliver the chemically ablative agent to tissue
10 surrounding the expandable cylindrical device without permanently trapping any agent in the openings.

39. The expandable medical device of Claim 38, further comprising a biodegradable barrier layer provided in the opening substantially adjacent an innermost surface of the cylindrical device.

15 40. An expandable medical device for treating cardiac arrhythmias, the device comprising:

an expandable cylindrical device having a plurality of struts;
a plurality of openings in the plurality of struts; and
an anti-arrhythmic drug and a non-biodegradable carrier provided in
20 the openings, wherein the openings are configured to deliver the anti-arrhythmic drug to tissue surrounding the cylindrical device over an extended time period.

41. The expandable medical device of Claim 40, further comprising a non-biodegradable barrier layer provided in the opening substantially adjacent an innermost surface of the cylindrical device.

-33-

42. A method of forming an expandable medical device, the method comprising:

providing an expandable medical device with a plurality of struts, said plurality of struts joined together to form a substantially cylindrical device

5 which is expandable from a cylinder having a first diameter to a cylinder having a second diameter;

forming at least one opening in at least one of the plurality of struts;

and

10 delivering at least one beneficial agent into in the at least one opening in a plurality of layers.

43. The method according to Claim 42, wherein the least one opening extends at least partially through the thickness of said struts.

44. The method according to Claim 42, wherein said at least one opening comprises a plurality of openings.

15 45. The method according to Claim 42, wherein said at least one opening extends through the thickness of said struts, so as to thereby define a through opening.

20 46. The method according to Claim 42, wherein said at least one opening has a depth less than the thickness of the struts, so as to thereby define a recess.

47. The method according to Claim 42, wherein the beneficial agent delivered is paclitaxel, or an analogue or derivative thereof.

-34-

48. The method according to Claim 42, wherein the beneficial agent delivered is rapamycin, or an analogue or derivative thereof.

1/9

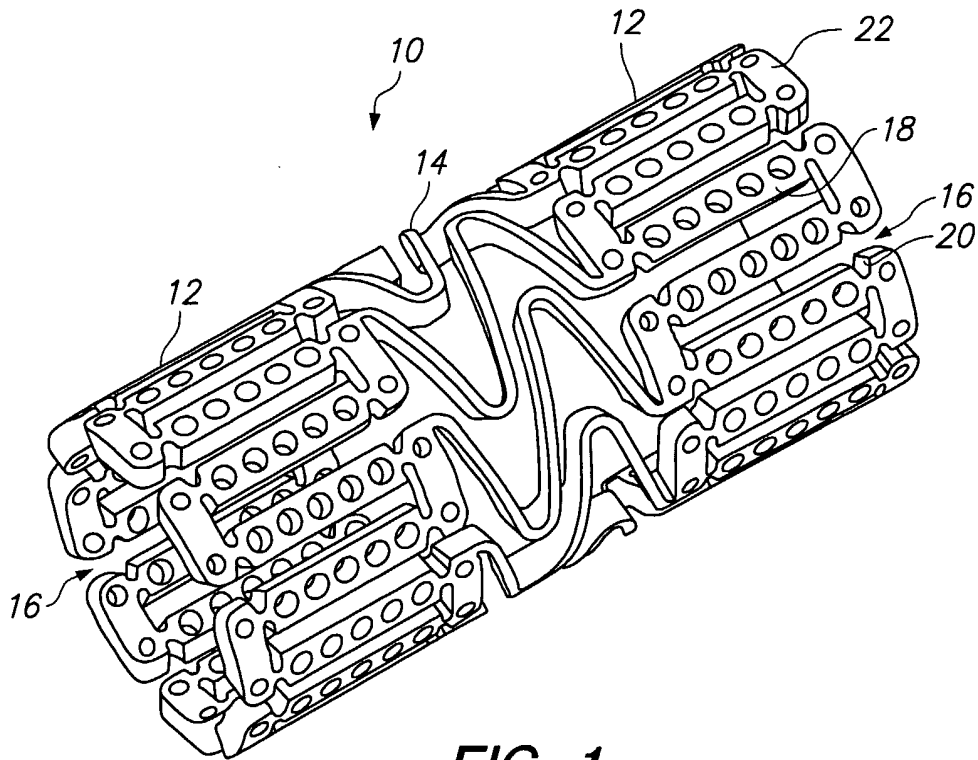

FIG. 1

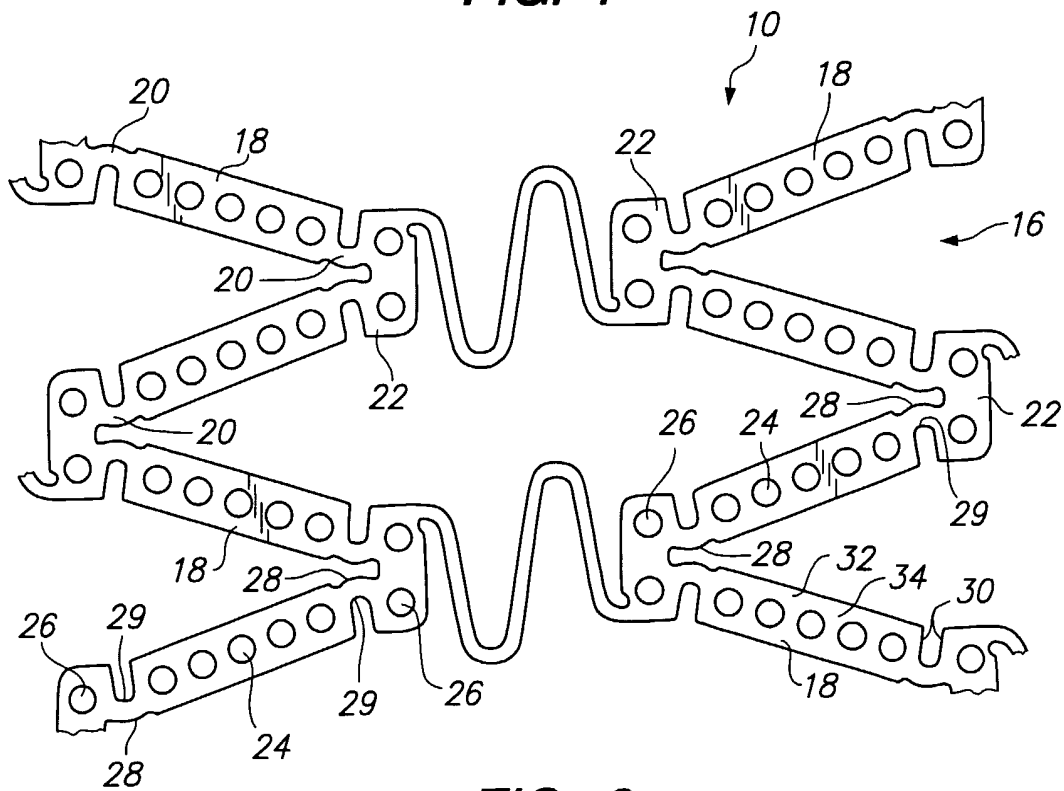

FIG. 2

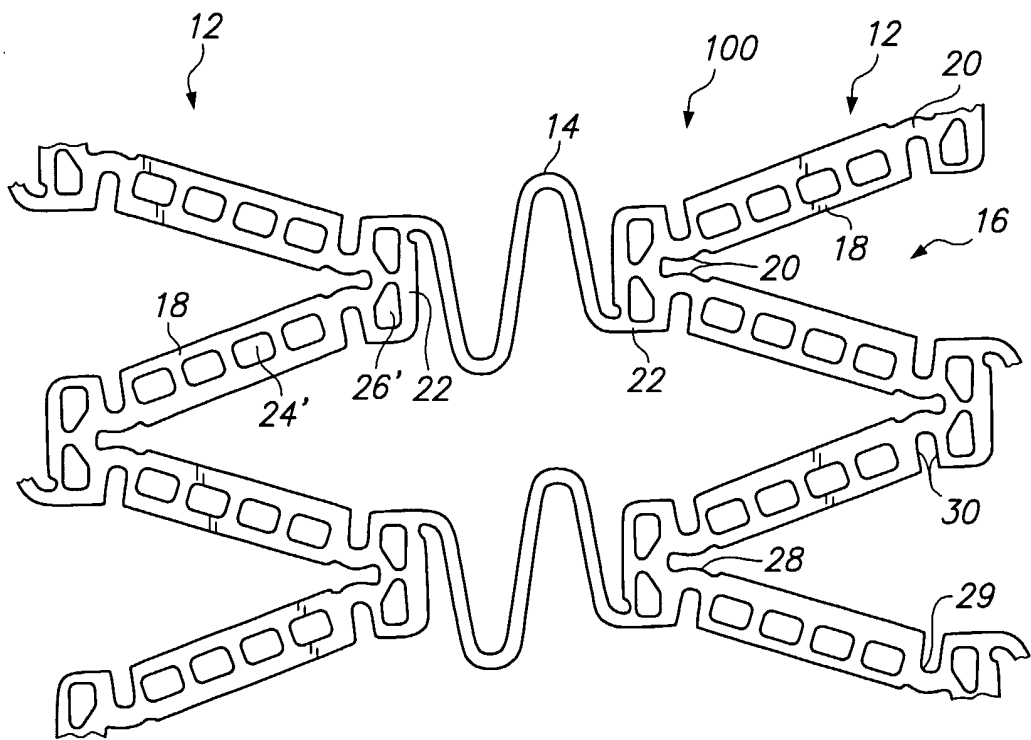

FIG. 3

FIG. 4

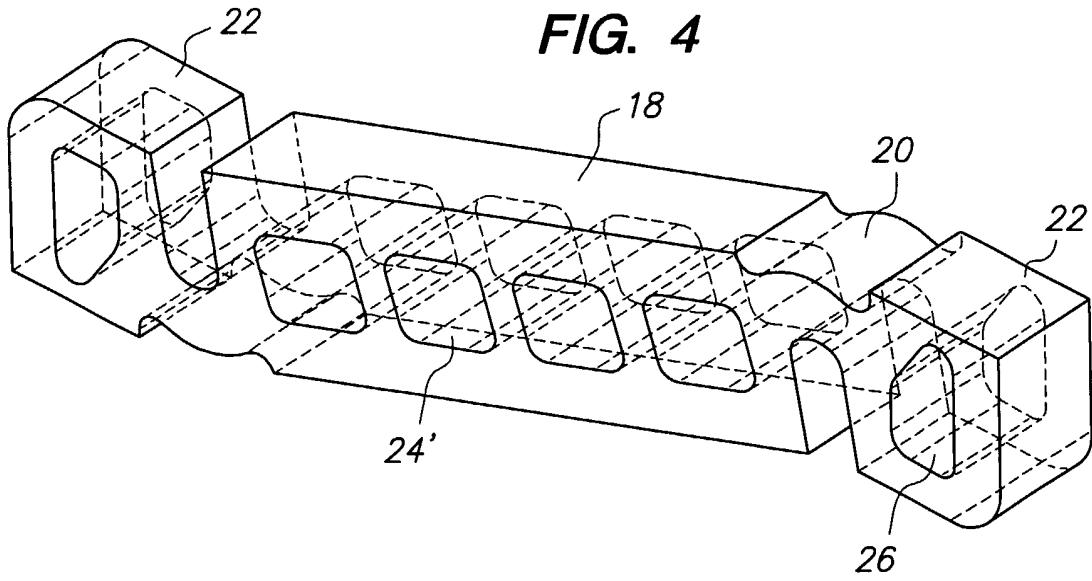

FIG. 5

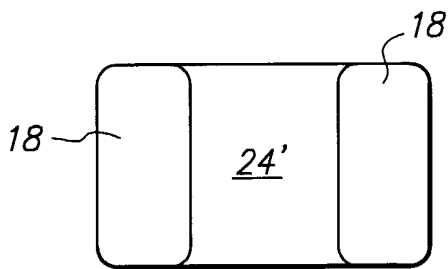

FIG. 6

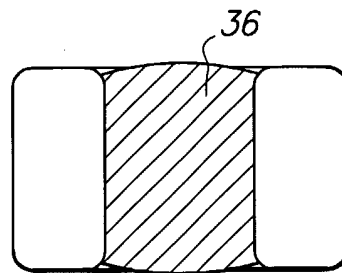

FIG. 7

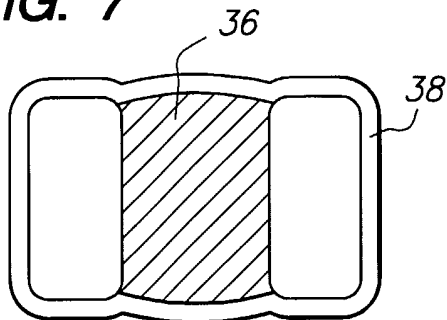
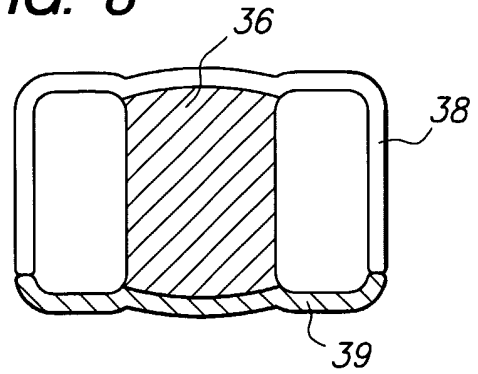

FIG. 8



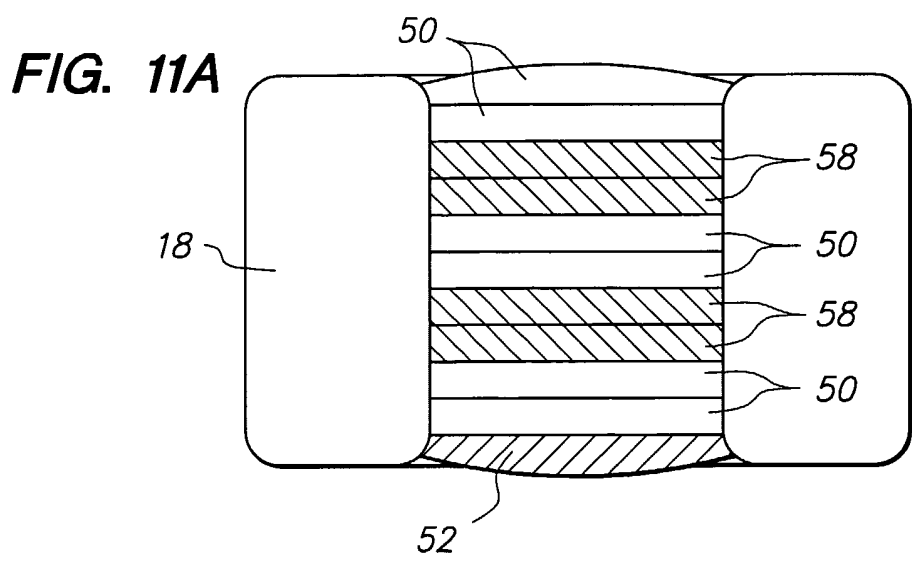
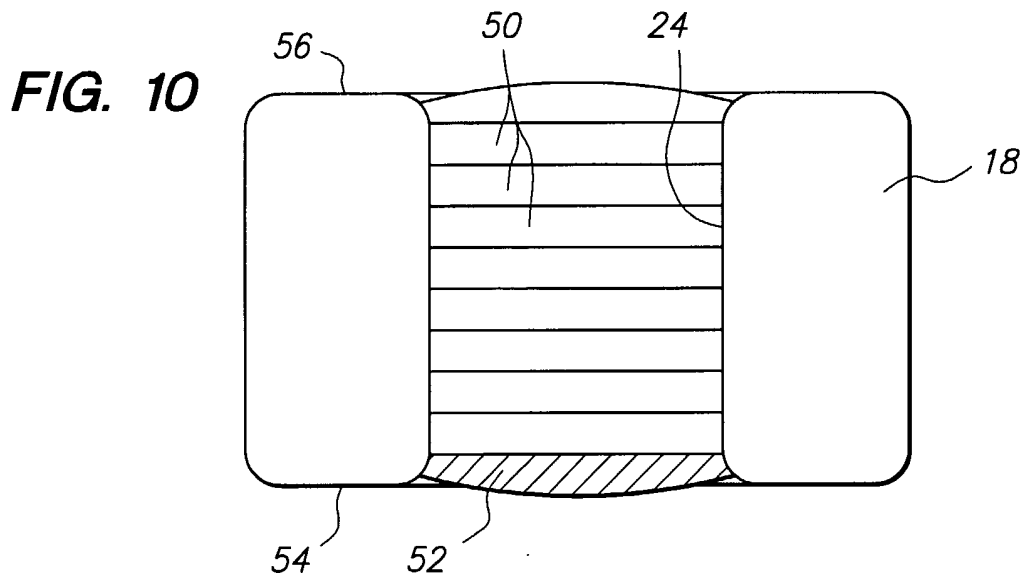
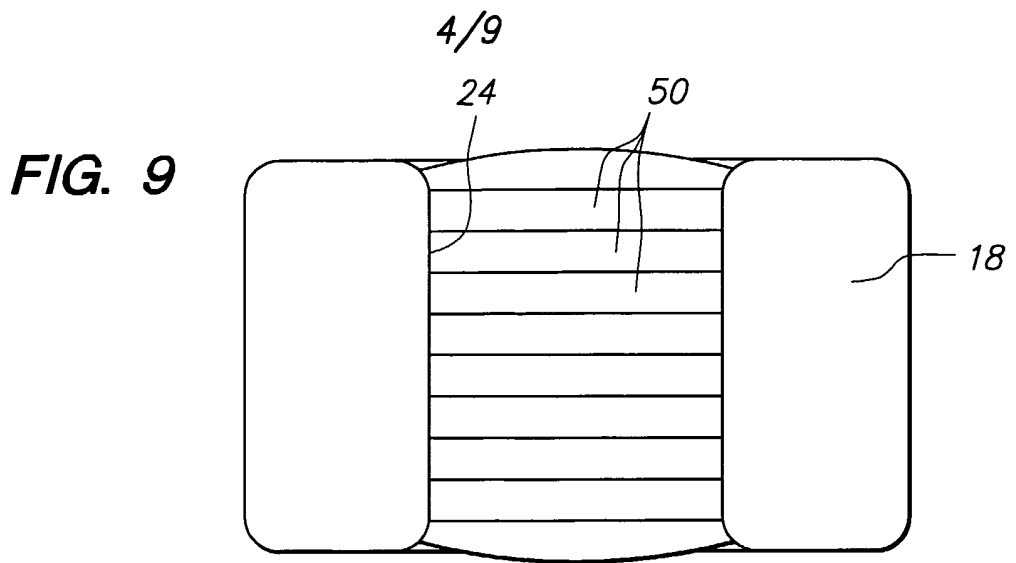

FIG. 11B

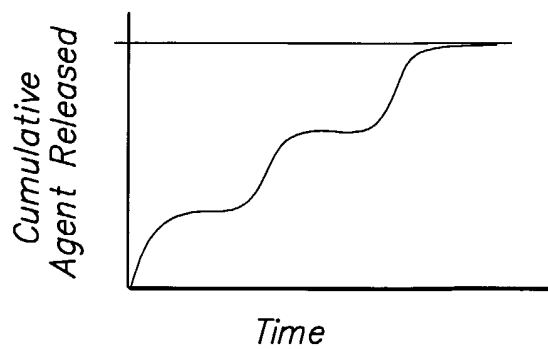

FIG. 12

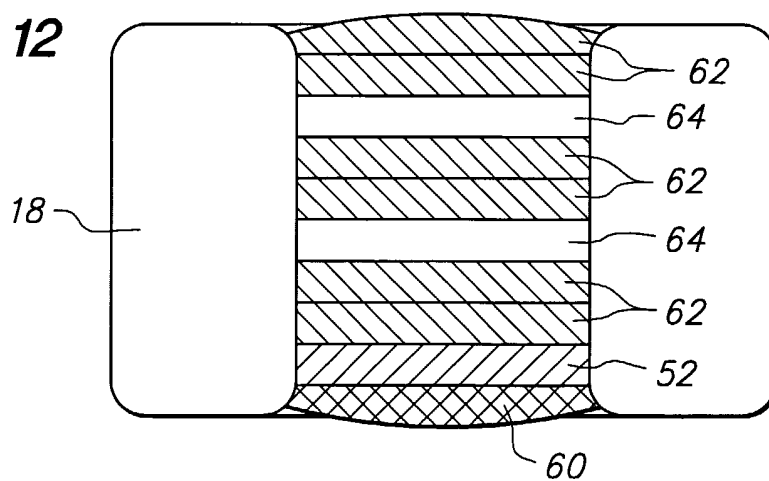

FIG. 13

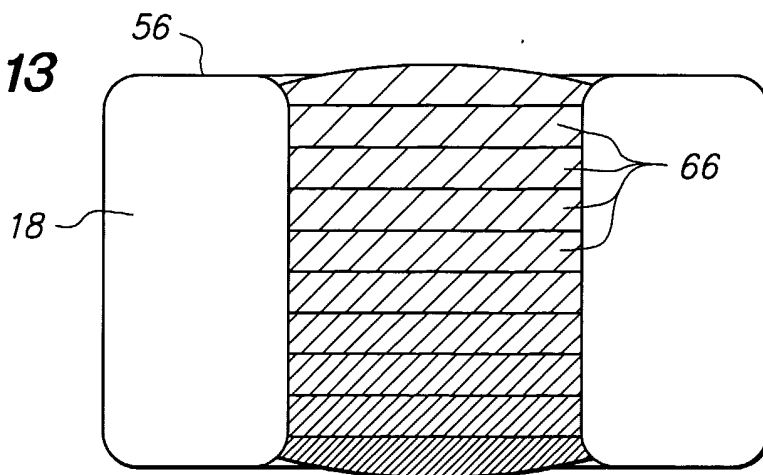

FIG. 14

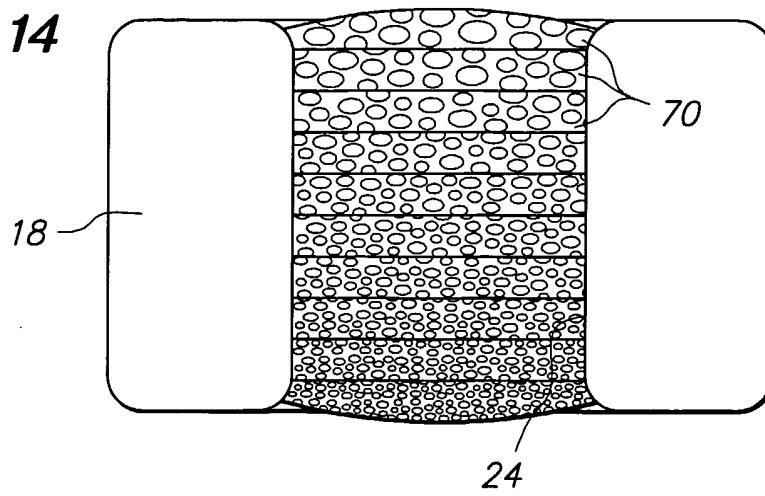

FIG. 15A

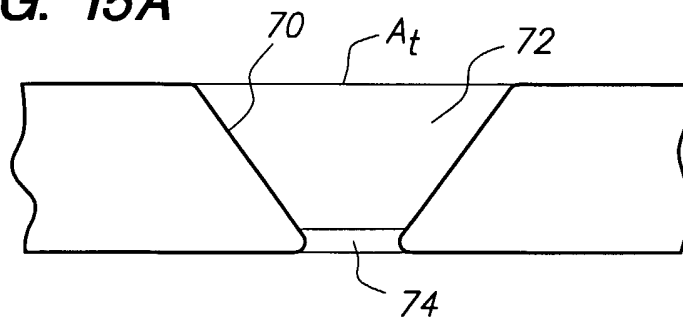

FIG. 15B

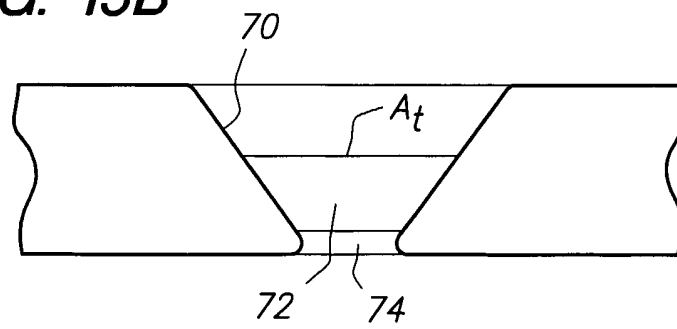
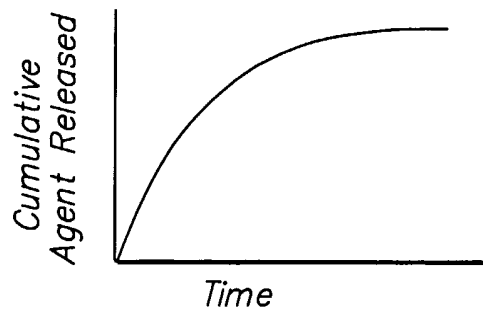

FIG. 15C



7/9

FIG. 16A

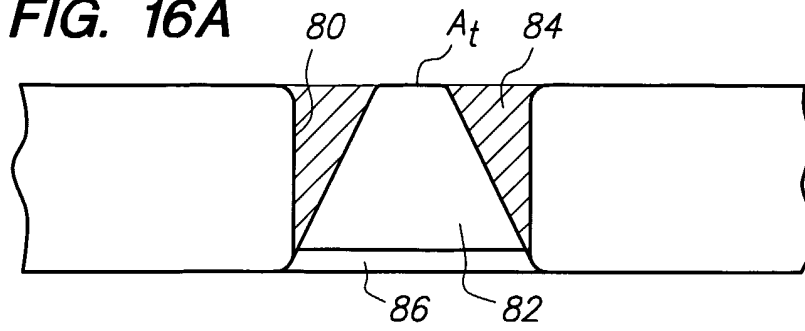

FIG. 16B

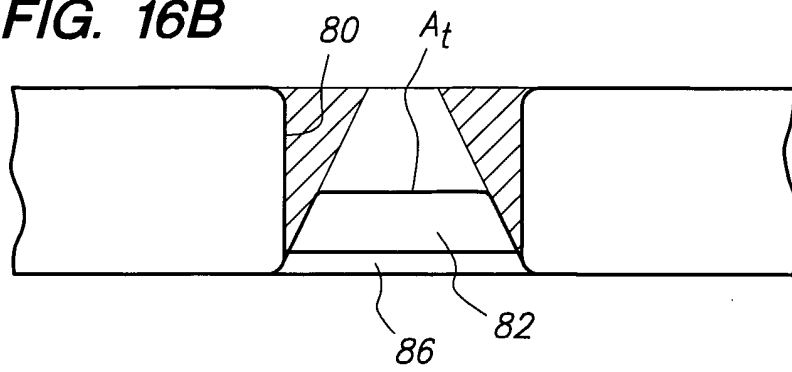

FIG. 17A

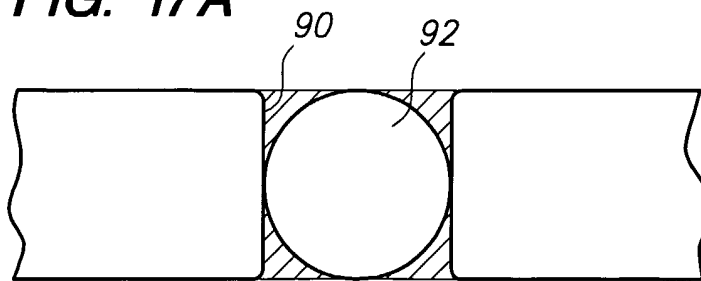

FIG. 16C

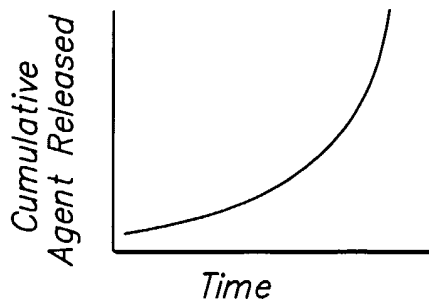
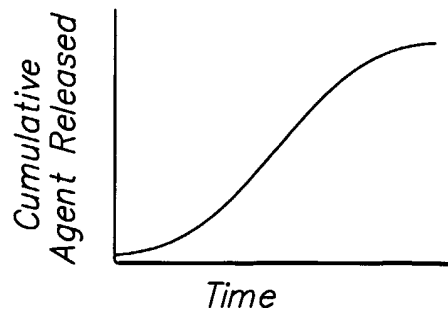

FIG. 17B



8/9

FIG. 18A

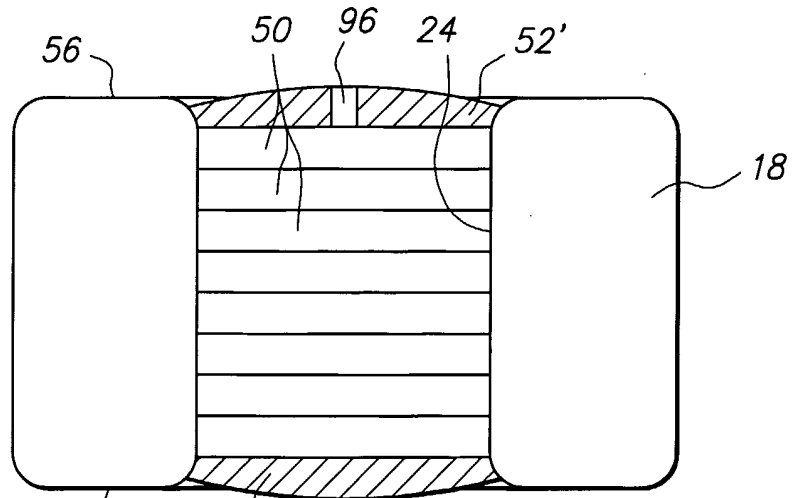

FIG. 18B

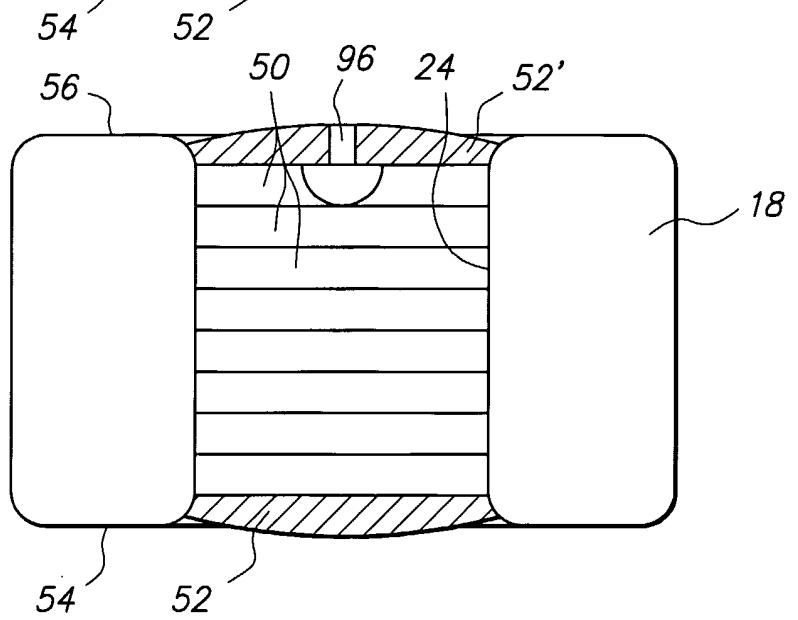
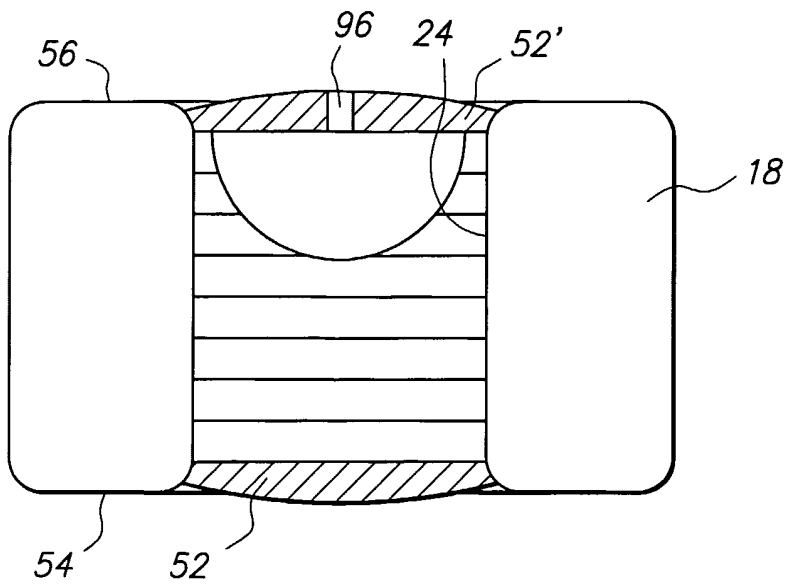
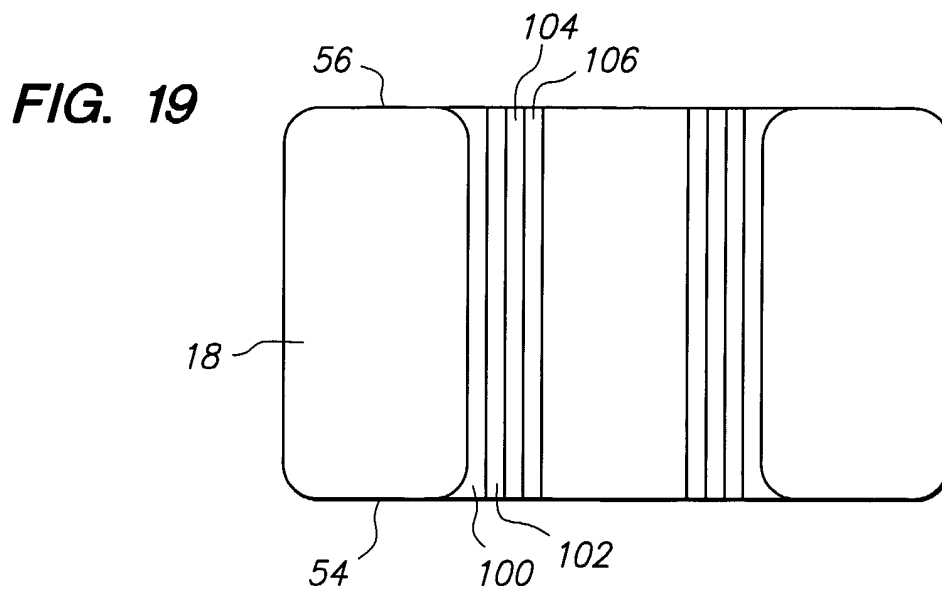

FIG. 18C





INTERNATIONAL SEARCH REPORT

International Application No
PCT/US 02/17609

A. CLASSIFICATION OF SUBJECT MATTER
IPC 7 A61F2/06

According to International Patent Classification (IPC) or to both national classification and IPC

B. FIELDS SEARCHED
Minimum documentation searched (classification system followed by classification symbols)
IPC 7 A61F

Documentation searched other than minimum documentation to the extent that such documents are included in the fields searched

Electronic data base consulted during the international search (name of data base and, where practical, search terms used)
EPO-Internal

C. DOCUMENTS CONSIDERED TO BE RELEVANT

Category °	Citation of document, with indication, where appropriate, of the relevant passages	Relevant to claim No.
X	<p>WO 98 36784 A (COOK INC) 27 August 1998 (1998-08-27)</p> <p>figures 8-10D page 11, line 23 -page 15, line 31 page 27, line 17 -page 29, line 20</p> <p style="text-align: center;">-/--</p>	<p>1-3, 5-13, 19-22, . 25-28, 30, 31, 37-44, 46</p>

Further documents are listed in the continuation of box C.

Patent family members are listed in annex.

- ° Special categories of cited documents :
- *A* document defining the general state of the art which is not considered to be of particular relevance
 - *E* earlier document but published on or after the international filing date
 - *L* document which may throw doubts on priority claim(s) or which is cited to establish the publication date of another citation or other special reason (as specified)
 - *O* document referring to an oral disclosure, use, exhibition or other means
 - *P* document published prior to the international filing date but later than the priority date claimed
 - *T* later document published after the international filing date or priority date and not in conflict with the application but cited to understand the principle or theory underlying the invention
 - *X* document of particular relevance; the claimed invention cannot be considered novel or cannot be considered to involve an inventive step when the document is taken alone
 - *Y* document of particular relevance; the claimed invention cannot be considered to involve an inventive step when the document is combined with one or more other such documents, such combination being obvious to a person skilled in the art.
 - *&* document member of the same patent family

Date of the actual completion of the international search 10 October 2002	Date of mailing of the international search report 17/10/2002
--	--

Name and mailing address of the ISA European Patent Office, P.B. 5818 Patentlaan 2 NL - 2280 HV Rijswijk Tel. (+31-70) 340-2040, Tx. 31 651 epo nl, Fax: (+31-70) 340-3016	Authorized officer Mary, C
--	-----------------------------------

INTERNATIONAL SEARCH REPORT

International Application No
PCT/US 02/17609

C.(Continuation) DOCUMENTS CONSIDERED TO BE RELEVANT		
Category °	Citation of document, with indication, where appropriate, of the relevant passages	Relevant to claim No.
X	<p>WO 01 17577 A (ADVANCED CARDIOVASCULAR SYSTEM) 15 March 2001 (2001-03-15)</p> <p>page 5, line 15 -page 10, line 7 page 13, line 8 -page 17, line 27</p> <p>---</p>	<p>1-3, 5-13, 19-28, 30,31, 35-39, 42-44, 46-48</p>
X A	<p>US 6 071 305 A (BROWN JAMES E ET AL) 6 June 2000 (2000-06-06) column 4, line 61 -column 13, line 43</p> <p>---</p>	<p>38-41</p> <p>1-37, 42-48</p>
P,X A	<p>US 2002/038145 A1 (JANG G DAVID) 28 March 2002 (2002-03-28)</p> <p>figure ALL paragraph '0028! - paragraph '0048!</p> <p>---</p>	<p>1-5, 27-30, 42-46</p> <p>38,40</p>
P,X A	<p>EP 1 132 058 A (ADVANCED LASER APPLIC HOLDING) 12 September 2001 (2001-09-12)</p> <p>page 5, paragraph 5 -page 18, paragraph 92</p> <p>---</p>	<p>1-3, 5-13,27, 28,30, 31, 42-44, 46-48</p> <p>38,40</p>
P,X	<p>WO 02 26281 A (CORDIS CORP) 4 April 2002 (2002-04-04)</p> <p>page 15, line 15 -page 21, line 22 page 22, line 17 -page 33, line 25</p> <p>---</p>	<p>1-3,24, 42-44, 46,48</p>
A,P	<p>DE 202 00 220 U (TRANSLUMINA GMBH) 21 March 2002 (2002-03-21) figure ALL page 9, line 19 -page 12, line 2</p> <p>-----</p>	<p>1-46</p>

INTERNATIONAL SEARCH REPORT

Information on patent family members

International Application No

PCT/US 02/17609

Patent document cited in search report		Publication date	Patent family member(s)	Publication date
WO 9836784	A	27-08-1998	AU 737252 B2	16-08-2001
			AU 6663298 A	09-09-1998
			EP 0968013 A1	05-01-2000
			JP 2001512354 T	21-08-2001
			WO 9836784 A1	27-08-1998
WO 0117577	A	15-03-2001	US 6287628 B1	11-09-2001
			US 6379381 B1	30-04-2002
			AU 6941800 A	10-04-2001
			EP 1214108 A1	19-06-2002
			WO 0117577 A1	15-03-2001
US 6071305	A	06-06-2000	AU 5266698 A	22-06-1998
			WO 9823228 A1	04-06-1998
			ZA 9710342 A	10-06-1998
US 2002038145	A1	28-03-2002	AU 8697401 A	02-04-2002
			WO 0224109 A2	28-03-2002
			US 2002058990 A1	16-05-2002
EP 1132058	A	12-09-2001	EP 1132058 A1	12-09-2001
			AU 5215401 A	17-09-2001
			WO 0166036 A2	13-09-2001
			US 2002007209 A1	17-01-2002
WO 0226281	A	04-04-2002	US 2001029351 A1	11-10-2001
			AU 1129902 A	08-04-2002
			AU 1132102 A	08-04-2002
			AU 7730201 A	11-04-2002
			AU 9316101 A	08-04-2002
			AU 9486901 A	08-04-2002
			EP 1192957 A2	03-04-2002
			WO 0226280 A1	04-04-2002
			WO 0226139 A1	04-04-2002
			WO 0226281 A1	04-04-2002
			WO 0226271 A1	04-04-2002
			US 2002094440 A1	18-07-2002
			US 2002111590 A1	15-08-2002
			US 2002133183 A1	19-09-2002
			US 2002051730 A1	02-05-2002
DE 20200220	U	21-03-2002	DE 20200220 U1	21-03-2002