



- (51) **International Patent Classification:** Not classified
- (21) **International Application Number:** PCT/EP2012/062105
- (22) **International Filing Date:** 22 June 2012 (22.06.2012)
- (25) **Filing Language:** English
- (26) **Publication Language:** English
- (30) **Priority Data:**
- | | | |
|------------|---------------------------|----|
| 13/167,781 | 24 June 2011 (24.06.2011) | US |
| 13/167,796 | 24 June 2011 (24.06.2011) | US |
| 13/167,837 | 24 June 2011 (24.06.2011) | US |
| 13/167,882 | 24 June 2011 (24.06.2011) | US |
- (71) **Applicant** (for all designated States except US): L'OREAL [FR/FR]; 14, Rue Royale, F-75008 Paris (FR).
- (72) **Inventors; and**
- (75) **Inventors/Applicants** (for US only): **HASHIMOTO, Sawa** [US/US]; 404 Locust Avenue, Garwood, New Jersey 07027 (US). **NGUYEN, Nghi Van** [US/US]; 8 Churchill Road, Edison, New Jersey 08837 (US). **TAN, Siliu** [CN/US]; 10 Plymouth Road, Westfield, New Jersey 07090 (US). **CERVANTES, Frederic** [FR/US]; 2 Faulkner Drive, Westfield, New Jersey 07090 (US).
- (74) **Agent:** **DOSSMANN, Gérard**; Bureau D.A. Casalonga & Josse, 8 Avenue Percier, F-75008 Paris (FR).
- (81) **Designated States** (unless otherwise indicated, for every kind of national protection available): AE, AG, AL, AM, AO, AT, AU, AZ, BA, BB, BG, BH, BR, BW, BY, BZ, CA, CH, CL, CN, CO, CR, CU, CZ, DE, DK, DM, DO, DZ, EC, EE, EG, ES, FI, GB, GD, GE, GH, GM, GT, HN, HR, HU, ID, IL, IN, IS, JP, KE, KG, KM, KN, KP, KR, KZ, LA, LC, LK, LR, LS, LT, LU, LY, MA, MD, ME, MG, MK, MN, MW, MX, MY, MZ, NA, NG, NI, NO, NZ, OM, PE, PG, PH, PL, PT, QA, RO, RS, RU, RW, SC, SD, SE, SG, SK, SL, SM, ST, SV, SY, TH, TJ, TM, TN, TR, TT, TZ, UA, UG, US, UZ, VC, VN, ZA, ZM, ZW.
- (84) **Designated States** (unless otherwise indicated, for every kind of regional protection available): ARIPO (BW, GH, GM, KE, LR, LS, MW, MZ, NA, RW, SD, SL, SZ, TZ, UG, ZM, ZW), Eurasian (AM, AZ, BY, KG, KZ, RU, TJ, TM), European (AL, AT, BE, BG, CH, CY, CZ, DE, DK, EE, ES, FI, FR, GB, GR, HR, HU, IE, IS, IT, LT, LU, LV, MC, MK, MT, NL, NO, PL, PT, RO, RS, SE, SI, SK, SM, TR), OAPI (BF, BJ, CF, CG, CI, CM, GA, GN, GQ, GW, ML, MR, NE, SN, TD, TG).
- Published:**
- without international search report and to be republished upon receipt of that report (Rule 48.2(g))

(54) **Title:** EMULSION DYEING COMPOSITION CONTAINING AN AMINE OR A PHOSPHOLIPID, AT LEAST ONE NON-IONIC SURFACTANT AND AT LEAST ONE SILICONE, AND METHOD OF USING SAME

(57) **Abstract:** The present invention is drawn to a composition and method for dyeing keratinous substrates containing: (a) at least one amine selected from the group comprising fatty monoamine compounds, polyamine compounds having at least three amino groups and fatty quaternary amine compounds, or at least one phospholipid; (b) at least one nonionic surfactant; (c) at least one anionic silicone; (d) at least one dye chosen from oxidation dye precursors and direct dyes. The compositions of the present invention may optionally contain at least one thickening agent, at least one alkaline agent, at least one fatty substance other than a fatty acid, at least one salt, and at least one oxidizing agent.



EMULSION DYEING COMPOSITION CONTAINING AN AMINE OR A
PHOSPHOLIPID, AT LEAST ONE NONIONIC SURFACTANT AND AT LEAST
ONE SILICONE, AND METHOD OF USING SAME

5 FILED OF THE INVENTION

[0001] The present invention relates to novel compositions for dyeing keratinous substrates based on a combination of at least one amine or at least one phospholipid, at least one nonionic surfactant, at least one anionic silicone and at
10 least one dye chosen from oxidation dye precursors and direct dyes.

BACKGROUND OF THE INVENTION

[0002] Throughout the years, people have sought to modify
15 the color of their skin, their eyelashes or their hair. Several techniques have been developed to achieve the desired color.

[0003] It is known to dye human keratinous substrates, such as the hair, with dye compositions comprising oxidation dye
20 precursors, which are also known as oxidation bases. To vary the shades obtained with these oxidation bases, additional couplers or coloration modifiers may be employed.

[0004] It is also known to dye human keratinous substrates by direct dyeing, which comprises applying to the keratinous
25 substrates direct dyes, which are colored.

[0005] Traditional application time for dyeing keratinous substrates is around thirty minutes. Such a period is considered to be too long under current tendency.

[0006] This problem cannot be solved by merely reducing the
30 application time of the dyeing compositions since it would be difficult to maintain the same satisfactory levels of coloring in shortened application times.

[0007] Another way to solve the problem is to increase the power of the oxidizing agent and the alkaline agent, by employing, for example, oxidizing agents of the type of the persalts, and/or alternatively by increasing the pH of the dyeing composition. However, such an option is undesirable, because of the increased risk of degradation of the keratinous substrates.

[0008] Therefore, there is a real need to develop dyeing compositions with improved efficiency to yield minimum degradation of the treated keratinous substrates while achieving improved levels of coloring in both conventional application time e.g., around 30 minutes and in shortened application times, e.g., around 15 minutes.

[0009] Another object of the present invention is to provide an effective dyeing composition capable of depositing acceptable levels of color onto keratinous substrates utilizing decreased levels of dye therein.

[00010] It is also desirable that such a composition can provide other advantageous properties to the hair such as shine, conditioning and a healthy appearance.

[00011] Finally, it is an object of the present invention to provide an effective dyeing composition with lowered cost of production.

25 BRIEF SUMMARY OF THE INVENTION

[00012] In order to achieve these and other advantages, the present invention is drawn to a dyeing aqueous composition for dyeing keratinous substrates containing, in a cosmetically acceptable medium:

30 a) at least one amine selected from the group comprising fatty monoamine compounds, polyamine compounds having at least three amino groups and

fatty quaternary amine compounds, or at least one phospholipid;

b) at least one nonionic surfactant;

c) at least one anionic silicone;

5 d) at least one dye chosen from oxidation dye precursors and direct dyes.

[00013] The present invention is also drawn to a method of dyeing keratinous substrates, comprising applying onto the keratinous substrates a dyeing aqueous composition containing,
10 in a cosmetically acceptable medium:

a) at least one amine selected from the group comprising fatty monoamine compounds, polyamine compounds having at least three amino groups and fatty quaternary amine compounds, or at least one
15 phospholipid ;

b) at least one nonionic surfactant;

c) at least one anionic silicone;

d) at least one dye chosen from oxidation dye precursors and direct dyes.

20 [00014] According to another embodiment of the invention, a kit for dyeing keratinous substrates is provided, comprising:

[00015] a first unit containing in a cosmetically acceptable medium: at least one amine selected from the group comprising fatty monoamine compounds, polyamine compounds having at least
25 three amino groups and fatty quaternary amine compounds, or at least one phospholipid; at least one nonionic surfactant; at least one anionic silicone; and at least one dye chosen from oxidation dye precursors and direct dyes; and

[00016] a second unit comprising at least one oxidizing
30 agent.

DETAILED DESCRIPTION OF THE INVENTION

[00017] Other than in the operating examples, or where

otherwise indicated, all numbers expressing quantities of ingredients and/or reaction conditions are to be understood as being modified in all instances by the term "about" which encompasses $\pm 10\%$.

5 [00018] "Amino groups" as defined herein includes primary amino groups, secondary amino groups, and tertiary amino groups, and further includes amino groups which are terminal, pendant, and intercalated in a skeleton of the at least one polyamine compound, but does not, for example, include
10 quaternary amino groups, amido groups, imino groups, nitrilo groups, or heteroatom analogs of any of the foregoing.

[00019] "At least one" as used herein means one or more and thus includes individual components as well as mixtures/combinations.

15 [00020] "Conditioning" as used herein means imparting to at least one keratinous fiber at least one property chosen from combability, manageability, moisture-retentivity, luster, shine, and softness. The state of conditioning is evaluated by measuring, and comparing, the ease of combability of the
20 treated hair and of the untreated hair in terms of combing work (gm-in).

[00021] "Formed from," as used herein, means obtained from chemical reaction of, wherein "chemical reaction," includes spontaneous chemical reactions and induced chemical reactions.

25 As used herein, the phrase "formed from", is open ended and does not limit the components of the composition to those listed, e.g., as component (i) and component (ii). Furthermore, the phrase "formed from" does not limit the order of adding components to the composition or require that the
30 listed components (e.g., components (i) and (ii)) be added to the composition before any other components.

[00022] "Hydrocarbons," as used herein, include alkanes, alkenes, and alkynes, wherein the alkanes comprise at least

one carbon, and the alkenes and alkynes each comprise at least two carbons; further wherein the hydrocarbons may be chosen from linear hydrocarbons, branched hydrocarbons, and cyclic hydrocarbons; further wherein the hydrocarbons may optionally
5 be substituted; and further wherein the hydrocarbons may optionally further comprise at least one heteroatom intercalated in the hydrocarbon chain.

[00023] "Silicone compound," as used herein, includes, for example, silica, silanes, silazanes, siloxanes, and
10 organosiloxanes; and refers to a compound comprising at least one silicon; wherein the silicone compound may be chosen from linear silicone compounds, branched silicone compounds, and cyclic silicone compounds; further wherein the silicone compound may optionally be substituted; and further wherein
15 the silicone compound may optionally further comprise at least one heteroatom intercalated in the silicone chain, wherein the at least one heteroatom is different from the at least one silicon.

[00024] "Substituted," as used herein, means comprising at
20 least one substituent. Non-limiting examples of substituents include atoms, such as oxygen atoms and nitrogen atoms, as well as functional groups, such as hydroxyl groups, ether groups, alkoxy groups, acyloxyalkyl groups, oxyalkylene groups, polyoxyalkylene groups, carboxylic acid groups, amine
25 groups, acylamino groups, amide groups, halogen containing groups, ester groups, thiol groups, sulphonate groups, thiosulphate groups, siloxane groups, and polysiloxane groups. The substituent(s) may be further substituted.

[00025] "Ethylene oxide group" as defined herein refers to a
30 group of formula $-\text{CH}_2\text{CH}_2-\text{O}-$.

[00026] "Propylene oxide group" as defined herein includes groups of formula $-\text{CH}_2\text{CH}_2\text{CH}_2-\text{O}-$, groups of formula $(\text{CH}_3)\text{CHCH}_2-$
 $\text{O}-$, and groups of formula $-\text{CH}_2(\text{CH}_3)\text{CH}-\text{O}-$.

[00027] "Keratinous substrate" may be chosen from, for example, hair, eyelashes, and eyebrows, as well as the stratum corneum of the skin and nails.

[00028] "Polymers," as defined herein, include homopolymers and copolymers formed from at least two different types of monomers.

[00029] The component (a) is at least one amine selected from the group comprising fatty quaternary amine compounds, fatty monoamine compounds and polyamine compounds having at least three amino groups, or at least one phospholipid.

FATTY MONOAMINE COMPOUND

[00030] In a first embodiment, the component (a) may be fatty monoamine compound(s).

[00031] In accordance with the present invention, fatty monoamine compounds are those compounds which have more than one hydrocarbon radical group wherein at least one hydrocarbon radical group is chosen from a C₆ to C₂₂ hydrocarbon radical group.

[00032] The fatty monoamine compounds of the present invention may be chosen from primary, secondary, and tertiary fatty monoamines.

[00033] The fatty monoamine compound may also contain an amide group. Particularly useful fatty monoamine compounds of the present invention are tertiary amido amines having an alkyl group of from about 6 to about 22 carbons. Exemplary tertiary amido amines include: stearamidopropyldimethylamine, stearamidopropyldiethylamine, stearamidoethyldiethylamine, stearamidoethyldimethylamine, palmitamidopropyldimethyl amine, palmitamidopropyldiethylamine, palmitamidoethyldiethylamine, palmitamidoethyldimethylamine, behenamidopropyldimethylamine, behenamidopropyldiethylamine, behenamidoethyldiethylamine,

behenamidoethyldimethylamine,
arachnidamidopropyldimethylamine,
arachidamidopropyldiethylamine, arachidamidoethyldiethylamine,
arachidamidoethyldimethylamine, diethylaminoethylstearamide.

5 [00034] Other particularly useful fatty monoamine compounds
of the present invention are dimethylstearamine,
dimethylsoyamine, soyamine, myristylamine, tridecylamine,
ethylstearylamine, arachidylbehenylamine, and alkoxyatedd
fatty amines such as ethoxylated stearylamine and. Useful
10 amines in the present invention are disclosed in U.S. Pat. No.
4,275,055.

[00035] Preferably, fatty monoamine compounds are chosen
from tertiary amidoamine having an alkyl group with from about
12 to about 22 carbon atoms.

15 [00036] In the present invention, the at least one fatty
monoamine compound is preferably used in an amount of from
greater than 0% to about 20% by weight, preferably from about
0.01% to about 10% by weight, and more preferably from about
0.1% to about 5% by weight, and even more preferably from
20 about 1% to about 4% by weight, based on the total weight of
the composition.

POLYAMINE COMPOUND

[00037] In a second embodiment, the component (a) may be
25 polyamine compounds comprising at least three amino groups.

[00038] The at least one polyamine compound of the present
invention comprises at least three amino groups; preferably at
least four amino groups; preferably at least five amino
groups; preferably at least ten amino groups.

30 [00039] In one embodiment of the present invention, the at
least one polyamine compound having at least three amino
groups may, for example, be chosen from aminated
polysaccharides comprising at least three amino groups, such

as, for example, hydrolysates of aminated polysaccharides comprising at least three amino groups. In one embodiment, polyamine compounds having at least three amino groups may, for example, be chosen from polymers. Suitable polymers for use as the at least one amine compound are polymers comprising at least three amino groups as defined herein. Non-limiting examples of suitable polymers include homopolymers comprising at least three amino groups, copolymers comprising at least three amino groups, and terpolymers comprising at least three amino groups. Thus, the at least one polyamine compound comprising at least three amino groups may be chosen from, for example, polymers comprising at least three amino groups formed from (i) at least one monomer unit comprising at least one amino group as defined herein, and, optionally, (ii) at least two additional monomer unit different from the at least one monomer (i); and polymers comprising at least three amino groups formed from (i) at least one monomer comprising at least three amino groups as defined herein, and, optionally, (ii) at least one additional monomer unit different from the at least three monomer (i). According to the present invention, the at least one additional monomer different from the at least one monomer (i) may or may not comprise at least one amino group as defined herein.

[00040] In one embodiment of the present invention, the at least one polyamine compound having at least three amino groups is chosen from polyamines. As used herein, "polyamines" comprise at least three repeating units, wherein each unit comprises at least one amino group as defined herein. In one embodiment, polyamines are chosen from polyethyleneimines. Polyethyleneimines suitable for use in the compositions of the present invention may optionally be substituted. Non-limiting examples of polyethyleneimines which may be used in the composition according to the present invention are the

Lupasol™ products commercially available from BASF. Suitable examples of Lupasol™ polyethyleneimines include Lupasol™ PS, Lupasol PL, Lupasol™ PR8515, Lupasol™ G20, Lupasol™ G35 as well as Lupasol™ SC® Polyethyleneimine Reaction Products (such as Lupasol™ SC-61B®, Lupasol™ SC-62J®, and Lupasol™ SC-86X®). Other non-limiting examples of polyethyleneimines which may be used in the composition according to the present invention are the Epomin™ products commercially available from Aceto. Suitable examples of Epomin™ polyethyleneimines include Epomin™ SP-006, Epomin™ SP-012, Epomin™ SP-018, and Epomin™ P-1000.

[00041] Polyamines suitable for use in the present invention may also be chosen from polyvinylamines. Examples thereof include Lupamines® 9095, 9030, 9010, 5095, 1595 from BASF.

[00042] The polyamine compound having at least three amino groups can also be substituted. An example of such a compound is PEG-15 Cocopolyamine from Cognis.

[00043] In another embodiment, the at least one polyamine compound comprising at least three amino groups is chosen from proteins and protein derivatives. Non-limiting examples of suitable proteins and protein derivatives for use in the present invention include those listed at pages 1701 to 1703 of the C.T.F.A. International Cosmetic Ingredient Dictionary and Handbook, 8th edition, vol. 2, (2000). In one embodiment, the at least one polyamine compound comprising at least three amino groups is chosen from wheat protein, soy protein, oat protein, collagen, and keratinous protein.

[00044] In one embodiment, the at least one polyamine compound comprising at least three amino groups is not chosen from proteins and protein derivatives. In one embodiment, the at least one polyamine compound comprising at least three amino groups is not chosen from compounds comprising lysine, compounds comprising arginine, and compounds comprising

histidine. In one embodiment, the at least one polyamine compound comprising at least three amino groups is chosen from compounds comprising lysine, compounds comprising arginine, compounds comprising histidine, and compounds comprising
5 hydroxylysine.

[00045] The polyamine compound having at least three amino groupss can also be substituted. An example of such a compound is PEG-15 Cocopolyamine from Cognis.

[00046] In another embodiment, the at least one polyamine
10 compound comprising at least three amino groups is chosen from proteins and protein derivatives. Non-limiting examples of suitable proteins and protein derivatives for use in the present invention include those listed at pages 1701 to 1703 of the C.T.F.A. International Cosmetic Ingredient Dictionary
15 and Handbook, 8th edition, vol. 2, (2000). In one embodiment, the at least one polyamine compound comprising at least three amino groups is chosen from wheat protein, soy protein, oat protein, collagen, and keratinous protein.

[00047] In another embodiment, the at least one polyamine
20 compound comprising at least three amino groups is chosen from proteins and protein derivatives. Non-limiting examples of suitable proteins and protein derivatives for use in the present invention include those listed at pages 1701 to 1703 of the C.T.F.A. International Cosmetic Ingredient Dictionary
25 and Handbook, 8th edition, vol. 2, (2000). In one embodiment, the at least one polyamine compound comprising at least three amino groups is chosen from wheat protein, soy protein, oat protein, collagen, and keratinous protein.

[00048] In one embodiment the at least one polyamine
30 compound comprising at least three amino groups is not chosen from proteins and protein derivatives. In one embodiment, the at least one polyamine compound comprising at least three amino groups is not chosen from compounds comprising lysine,

compounds comprising arginine, and compounds comprising histidine. In one embodiment, the at least one polyamine compound comprising at least three amino groups is chosen from compounds comprising lysine, compounds comprising arginine, 5 compounds comprising histidine, and compounds comprising hydroxylysine.

[00049] Preferably, the polyamine compound having at least three amino groups is chosen from polyethyleneimine and polyvinylamine.

10 [00050] In one embodiment, the polyamine compound having at least three amino groups is polyethyleneimine.

[00051] In one embodiment, the polyamine compound having at least three amino groups is polyvinylamine.

[00052] In the present invention, the at least one polyamine 15 compound having at least three amino groups is preferably used in an amount of from greater than 0% to about 30% by weight, more preferably greater than 0% to about 20% by weight, particularly from about 0.01% to about 10% by weight, and more preferably from about 0.1% to about 5% by weight, and even 20 more preferably from about 1% to about 4% by weight, based on the weight of the composition as a whole.

FATTY QUATERNARY AMINE COMPOUND

[00053] In a third embodiment, the component (a) may be 25 fatty quaternary amine compound(s).

[00054] The present invention provides for the use of conventional fatty quaternary amine compounds containing from 6 to 22 carbon atoms. The anion of the quaternary ammonium compound can be a common ion such as chloride, ethosulfate, 30 methosulfate, acetate, bromide, lactate, nitrate, phosphate, or tosylate and mixtures thereof. The long chain alkyl groups can include additional or replaced carbon or hydrogen atoms or ether linkages. Other substitutions on the quaternary nitrogen

can be hydrogen, benzyl or short chain alkyl or hydroxyalkyl groups such as methyl, ethyl, hydroxymethyl or hydroxyethyl, hydroxypropyl or combinations thereof.

[00055] Examples of fatty quaternary ammonium compounds
5 include but are not limited to: Behentrimonium chloride,
Cocotrimonium chloride, Cethethyldimonium bromide,
Dibehenyldimonium chloride, Dihydrogenated tallow benzylmonium
chloride, disoyadimonium chloride, Ditalowdimonium chloride,
Hydroxycetyl hydroxyethyl dimonium chloride, Hydroxyethyl
10 Behenamidopropyl dimonium chloride, Hydroxyethyl Cetyldimonium
chloride, Hydroxyethyl tallowdimonium chloride, myristalkonium
chloride, PEG-2 Oleamonium chloride, PEG-5 Stearmonium
chloride, PEG-15 cocoyl quaternium 4, PEG-2 stearalkonium 4,
lauryltrimonium chloride; Quaternium-16; Quaternium-18,
15 lauralkonium chloride, olealkonium chloride, cetylpyridinium
chloride, Polyquaternium-5, Polyquaternium-6, Polyquaternium-
7, Polyquaternium-10, Polyquaternium-22, Polyquaternium-37,
Polyquaternium-39, Polyquaternium-47, cetyl trimonium
chloride, dilauryldimonium chloride, cetalkonium chloride,
20 dicetyldimonium chloride, soyatrimonium chloride, stearyl
octyl dimonium methosulfate, behentrimonium methosulfate (18-
MEA), stearalkonium chloride, and mixtures thereof. Other
quaternary ammonium compounds are listed in the CTFA Cosmetic
Ingredient Handbook, First Edition, on pages 41-42,
25 incorporated herein by reference.

[00056] In the present invention, the at least one fatty
quaternary amine compound is preferably used in an amount of
from greater than 0% to about 30% by weight, preferably from
about 0.1% to about 20% by weight, and more preferably from
30 about 1% to about 10%, or from about 2% to about 5% by weight,
based on the weight of the composition as a whole.

PHOSPHOLIPID

[00057] In a fourth embodiment, the component (a) is at least one phospholipid.

[00058] The present invention provides for the use of conventional organic phospholipids. Particularly preferred organic phospholipids include lecithins. Lecithins are mixtures of phospholipids, i.e., of diglycerides of fatty acids linked to an ester of phosphoric acid. Preferably, lecithins are diglycerides of stearic, palmitic, and oleic acids linked to the choline ester of phosphoric acid. Lecithin is usually defined either as pure phosphatidyl cholines or as crude mixtures of phospholipids which include phosphatidyl choline, phosphatidyl serine, phosphatidyl ethanolamine, phosphatidyl inositol, other phospholipids, and a variety of other compounds such as fatty acids, triglycerides, sterols, carbohydrates, and glycolipids.

[00059] The lecithin used in the present invention may be present in the form of a liquid, powder, or granules. Lecithins useful in the invention include, but are not limited to, soy lecithin and hydroxylated lecithin. For example, ALCOLEC S is a fluid soy lecithin, ALCOLEC F 100 is a powder soy lecithin, and ALCOLEC Z3 is a hydroxylated lecithin, all of which are available from the American Lecithin Company.

[00060] Other than lecithins, additional examples of phospholipids which may be useful in the present invention include, but are not limited to, multifunctional biomimetic phospholipids. For example, the following multifunctional biomimetic phospholipids manufactured by Uniqema Industries may be useful: cocamidopropyl PG-dimonium chloride phosphate (PHOSPHOLIPID PTC), sodium coco PG-dimonium chloride phosphate (PHOSPHOLIPID CDM), stearamidopropyl PG-dimonium chloride phosphate (PHOSPHOLIPID SV), sodium borageamidopropyl PG-dimonium chloride phosphate (PHOSPHOLIPID GLA), and

linoleamidopropyl PG-dimonium chloride phosphate (PHOSPHOLIPID EFA). A preferred multifunctional biomimetic phospholipid in the present invention is linoleamidopropyl PG-dimonium chloride phosphate.

5 [00061] In one embodiment, the phospholipid is lecithin.

[00062] In one embodiment, the phospholipid is linoleamidopropyl PG-dimonium chloride phosphate.

[00063] In the present invention, the at least one phospholipid compound is preferably used in an amount of from
10 greater than 0% to about 30% by weight, preferably in an amount of from greater than 0% to about 20% by weight, more particularly from about 0.01% to about 10% by weight, and more preferably from about 0.1% to about 5% by weight, and even more preferably from about 1% to about 4% by weight, based on
15 the weight of the composition as a whole.

[00064] Preferably, the component (a) is chosen from tertiary amidoamine having an alkyl group with from 12 to 22 carbon atoms, polyethyleneimine, polyvinylamine,
20 behentrimonium chloride, lecithin and linoleamidopropyl PG-dimonium chloride phosphate.

[00065] In the present invention, the component (a) is preferably used in an amount of from greater than 0 to about
25 30% by weight, particularly from greater than 0 to about 20% by weight, more particularly from about 0.01% by weight to about 10% by weight, and more preferably from about 0.1% to about 5% by weight, and even more preferably from about 1% to about 4% by weight, based on the total weight of the
30 composition.

NONIONIC SURFACTANTS

[00066] In general, nonionic surfactants having a Hydrophilic-Lipophilic Balance (HLB) of at least 8, preferably from about 8 to about 20, are contemplated for use by the present invention. Nonlimiting examples of nonionic surfactants useful in the compositions of the present invention are disclosed in McCutcheon's "Detergents and Emulsifiers," North American Edition (1986), published by Allured Publishing Corporation; and McCutcheon's "Functional Materials," North American Edition (1992); both of which are incorporated by reference herein in their entirety.

[00067] Examples of nonionic surfactants useful herein include, but are not limited to, alkoxyated derivatives of the following: fatty alcohols, alkyl phenols, fatty acids, fatty acid esters and fatty acid amides, wherein the alkyl chain is in the C₁₂-C₅₀ range, preferably in the C₁₆-C₄₀ range, more preferably in the C₂₄ to C₄₀ range, and having from about 1 to about 110 alkoxy groups. The alkoxy groups are selected from the group consisting of C₂-C₆ oxides and their mixtures, with ethylene oxide, propylene oxide, and their mixtures being the preferred alkoxides. The alkyl chain may be linear, branched, saturated, or unsaturated. Of these alkoxyated non-ionic surfactants, the alkoxyated alcohols are preferred, and the ethoxyated alcohols and propoxyated alcohols are more preferred. The alkoxyated alcohols may be used alone or in mixtures thereof. The alkoxyated alcohols may also be used in mixtures with those alkoxyated materials disclosed herein-above.

[00068] Other representative examples of such ethoxyated fatty alcohols include laureth-3 (a lauryl ethoxylate having an average degree of ethoxylation of 3), laureth-23 (a lauryl ethoxylate having an average degree of ethoxylation of 23), ceteth-10 (a cetyl alcohol ethoxylate having an average degree

of ethoxylation of 10) steareth-10 (a stearyl alcohol ethoxylate having an average degree of ethoxylation of 10), and steareth-2 (a stearyl alcohol ethoxylate having an average degree of ethoxylation of 2), steareth-100 (a stearyl alcohol ethoxylate having an average degree of ethoxylation of 100),
5 beheneth-5 (a behenyl alcohol ethoxylate having an average degree of ethoxylation of 5), beheneth-10 (a behenyl alcohol ethoxylate having an average degree of ethoxylation of 10), and other derivatives and mixtures of the preceding.

10 [00069] Also available commercially are Brij® nonionic surfactants from Uniqema, Wilmington, DE. Typically, Brij® is the condensation products of aliphatic alcohols with from about 1 to about 54 moles of ethylene oxide, the alkyl chain of the alcohol being typically a linear chain and having from
15 about 8 to about 22 carbon atoms, for example, Brij 72 (i.e., Steareth-2) and Brij 76 (i.e., Steareth-10).

[00070] Also useful herein as nonionic surfactants are alkyl glycosides, which are the condensation products of long chain alcohols, e.g. C₈ to C₃₀ alcohols, with sugar or starch
20 polymers. These compounds can be represented by the formula (S)_n--O--R wherein S is a sugar moiety such as glucose, fructose, mannose, galactose, and the like; n is an integer of from about 1 to about 1000, and R is a C₈ to C₃₀ alkyl group. Examples of long chain alcohols from which the alkyl group can
25 be derived include decyl alcohol, cetyl alcohol, stearyl alcohol, lauryl alcohol, myristyl alcohol, oleyl alcohol, and the like. Preferred examples of these surfactants are alkyl polyglucosides wherein S is a glucose moiety, R is a C₈ to C₂₀ alkyl group, and n is an integer of from about 1 to about 9.
30 Commercially available examples of these surfactants include decyl polyglucoside (available as APG® 325 CS) and lauryl polyglucoside (available as APG® 600CS and 625 CS), all the above-identified polyglucosides are available from Cognis,

Ambler, Pa. Also useful herein are sucrose ester surfactants such as sucrose cocoate and sucrose laurate.

[00071] Other nonionic surfactants suitable for use in the present invention are glyceryl esters and polyglyceryl esters, including but not limited to, glyceryl monoesters, preferably
5 glyceryl monoesters of C₁₆-C₂₂ saturated, unsaturated and branched chain fatty acids such as glyceryl oleate, glyceryl monostearate, glyceryl monoisostearate, glyceryl monopalmitate, glyceryl monobehenate, and mixtures thereof,
10 and polyglyceryl esters of C₁₆-C₂₂ saturated, unsaturated and branched chain fatty acids, such as polyglyceryl-4 isostearate, polyglyceryl-3 oleate, polyglyceryl-2 sesquioleate, triglyceryl diisostearate, diglyceryl monooleate, tetraglyceryl monooleate, and mixtures thereof.

[00072] Also useful herein as nonionic surfactants are
15 sorbitan esters. Preferable are sorbitan esters of C₁₆-C₂₂ saturated, unsaturated and branched chain fatty acids. Because of the manner in which they are typically manufactured, these sorbitan esters usually comprise mixtures of mono-, di-, tri-,
20 etc. esters. Representative examples of suitable sorbitan esters include sorbitan monooleate (e.g., SPAN® 80), sorbitan sesquioleate (e.g., Arlacel® 83, Uniqema), sorbitan monoisostearate (e.g., CRILL® 6 from Croda, Inc., Edison, N.J.), sorbitan stearates (e.g., SPAN® 60), sorbitan trioleate
25 (e.g., SPAN® 85), sorbitan tristearate (e.g., SPAN® 65), sorbitan dipalmitates (e.g., SPAN® 40), and sorbitan isostearate. Sorbitan monoisostearate and sorbitan sesquioleate are particularly preferred emulsifiers for use in the present invention.

[00073] Also suitable for use herein are alkoxyated
30 derivatives of glyceryl esters, sorbitan esters, and alkyl polyglycosides, wherein the alkoxy groups is selected from the

group consisting of C₂-C₆ oxides and their mixtures, with ethoxylated or propoxylated derivatives of these materials being the preferred. Nonlimiting examples of commercially available ethoxylated materials include TWEEN® (ethoxylated sorbitan mono-, di- and/or tri-esters of C₁₂ to C₁₈ fatty acids with an average degree of ethoxylation of from about 2 to about 20).

[00074] Preferred nonionic surfactants are those formed from a fatty alcohol, a fatty acid, or a glyceride with a C₄ to C₃₆ carbon chain, preferably a C₁₂ to C₁₈ carbon chain, more preferably a C₁₆ to C₁₈ carbon chain, derivatized to yield an HLB of at least 8. HLB is understood to mean the balance between the size and strength of the hydrophilic group and the size and strength of the lipophilic group of the surfactant. Such derivatives can be polymers such as ethoxylates, propoxylates, polyglucosides, polyglycerins, polylactates, polyglycolates, polysorbates, and others that would be apparent to one of ordinary skill in the art. Such derivatives may also be mixed polymers of the above, such as ethoxylate/propoxylate species, where the total HLB is preferably at least 8. Preferably the nonionic surfactants contain ethoxylate in a molar content of from about 10-25, more preferably from about 10-20 moles.

[00075] The nonionic surfactant will typically be present in the composition in an amount of from greater than 0% to about 70% by weight, preferably from about 0.1% to about 50% by weight, and more preferably from about 1% to about 30% by weight, and even more preferably from about 5% to about 20% by weight based on the total weight of the composition.

ANIONIC SILICONE

[00076] In general, non-limiting examples of anionic silicones which may be used in the present invention include

silicone carboxylates, silicone phosphates, silicone sulfates, silicone sulfosuccinates, and silicone sulfonates.

[00077] Suitable silicone carboxylates may be chosen from water soluble silicone compounds comprising at least one
 5 carboxylic acid group, oil soluble silicone compounds comprising at least one carboxylic acid group, water-dispersible silicone compounds comprising at least one carboxylic acid group, and silicone compounds comprising at least one carboxylic acid group which are soluble in organic
 10 solvents. In one embodiment, the at least one silicone compound comprising at least one carboxylic acid group further comprises at least one alkoxy chain, wherein the at least one alkoxy group may be chosen from terminal alkoxy groups, pendant alkoxy groups, and alkoxy groups which are
 15 intercalated in the skeleton of the at least one silicone compound. Non-limiting examples of at least one alkoxy group include ethylene oxide groups and propylene oxide groups.

[00078] The at least one carboxylic acid group may be chosen from terminal carboxylic acid groups and pendant carboxylic
 20 acid groups. Further, the at least one carboxylic acid may be chosen from carboxylic acid groups in free acid form, *i.e.*, -COOH, and carboxylic acid groups in salt form, *i.e.*, -COOM, wherein M may be chosen from inorganic cations, such as, for example, potassium cations and sodium cations, and organic
 25 cations.

[00079] In one embodiment, the at least one silicone compound comprising at least one carboxylic acid group is chosen from silicone compounds of formula (I) and salts thereof:

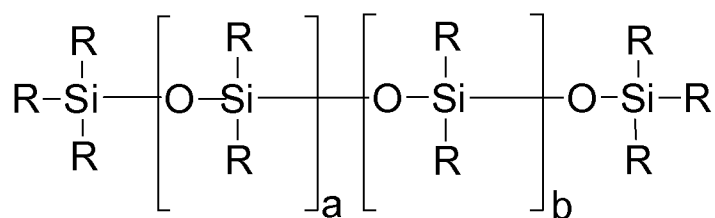

(I)

[00080] wherein: a is an integer ranging from 1 to 100; b is an integer ranging from 0 to 500; R, which may be identical or different, are each chosen from optionally substituted hydrocarbon groups comprising from 1 to 9 carbon atoms, optionally substituted phenyl groups, and groups of formula (II):

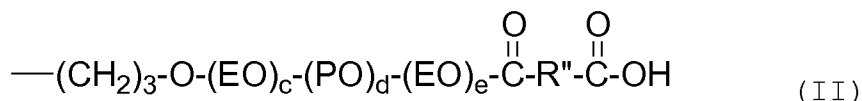

[00081] wherein: c, d, and e, which may be identical or different, are each integers ranging from 0 to 20; EO is an ethylene oxide group; PO is a propylene oxide group; and R'' is chosen from optionally substituted divalent hydrocarbons, such as alkylene groups and alkenylene groups comprising from 2 to 22 carbon atoms, and optionally substituted divalent aromatic groups, such as groups of formula (III):

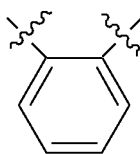

15 and groups of formula (IV):

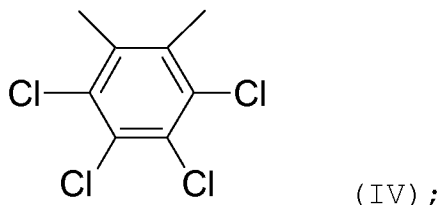

[00082] with the proviso that at least one of the R groups is chosen from groups of formula (II) and with the further proviso that when only one of the R groups is chosen from groups of formula (II), the other R groups are not all methyl groups.

[00083] Non-limiting examples of the at least one silicone compound include those commercially available from Noveon under the name Ultrasil ® CA-1 Silicone and Ultrasil ® CA-2 Silicone, both of which correspond to formula (V) below. This

silicone carboxylate is sold in the free acid form as an emulsifier and dispersing aid for complexing fatty cationic amines and quaternary amines. Thus, in one embodiment, the at least one silicone compound is chosen from silicone compounds
 5 of formula (V) and salts thereof:

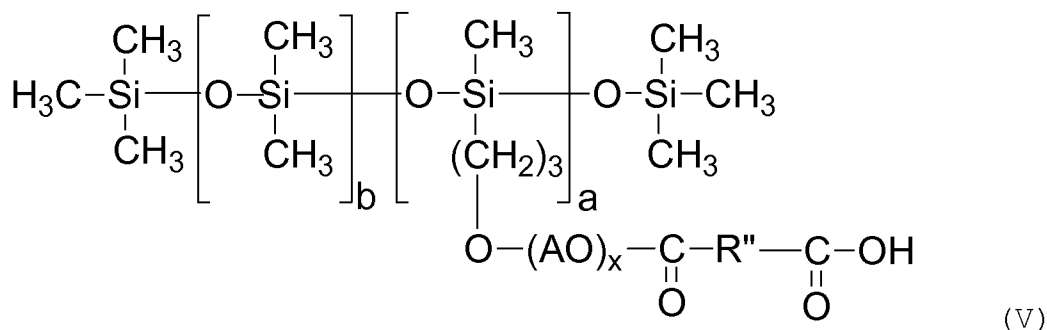

[00084] wherein: a is an integer ranging from 1 to 100; b is an integer ranging from 0 to 500; AO is chosen from groups of formula (VI):

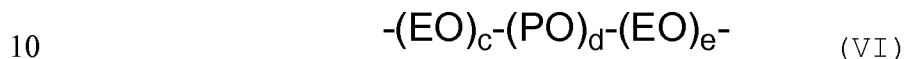

[00085] wherein: c, d, and e, which may be identical or different, are each integers ranging from 0 to 20; EO is an ethylene oxide group; and PO is a propylene oxide group; x is an integer ranging from 0 to 60; R'' is chosen from
 15 optionally substituted divalent hydrocarbons, such as alkylene groups and alkenylene groups comprising from 2 to 22 carbon atoms, and optionally substituted divalent aromatic groups, such as groups of formula (III):

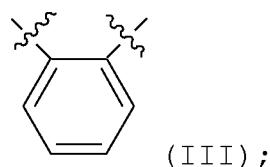

20 and groups of formula (IV):

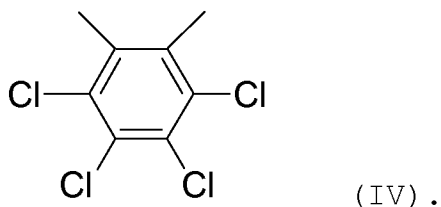

[00086] Non-limiting examples of the at least one silicone compound include those described in U.S. Patent Nos. 5,248,783 and 5,739,371, the disclosures of which are incorporated herein by reference, and which are silicone compounds of
5 formula (I).

[00087] Suitable silicone phosphates may be chosen from water-soluble silicone compounds comprising at least one phosphate group, oil soluble silicone compounds comprising at least one phosphate group, water-dispersible silicone
10 compounds comprising at least one phosphate group, and silicone compounds comprising at least one phosphate group which are soluble in organic solvents.

[00088] In one embodiment, the at least one silicone compound comprising at least one phosphate group further
15 comprises at least one alkoxy chain, wherein the at least one alkoxy group may be chosen from terminal alkoxy groups, pendant alkoxy groups, and alkoxy groups which are intercalated in the skeleton of the at least one silicone compound. Non-limiting examples of at least one alkoxy group
20 include ethylene oxide groups ("EO" = -CH₂-CH₂-O-) and propylene oxide groups ("PO" = C₃H₆O).

[00089] The at least one phosphate group may be chosen from terminal phosphate groups and pendant phosphate groups. Further, the at least one phosphate group may be chosen from
25 groups of formula -O-P(O)(OH)₂, groups of formula -O-P(O)(OH)(OR), and groups of formula -O-P(O)(OR)₂, wherein R may be chosen from H, inorganic cations, and organic cations. Non-limiting examples of inorganic cations include alkali metals, such as, for example, potassium lithium, and sodium.
30 A non-limiting example of organic cations is at least one additional silicone compound which may be identical to or different from the at least one silicone compound bonded to the other oxygen of the phosphate group.

[00090] In one embodiment, the at least one silicone compound comprising at least one phosphate group is chosen from silicone compounds of formula (VII):

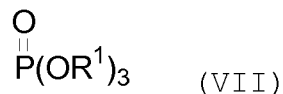

5 [00091] wherein R^1 , which may be identical or different, are each chosen from H, organic cations, inorganic cations, optionally substituted hydrocarbons (such as alkyl groups and alkenyl groups comprising from 1 to 22 carbon atoms), optionally substituted aromatic groups; groups of formula
10 (VIII) and salts thereof:

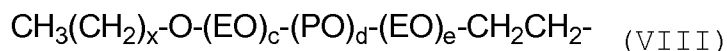

[00092] wherein: c, and d, which may be identical or different, are each integers ranging from 0 to 20; e is an integer ranging from 0 to 19; and x is an integer ranging from
15 0 to 21; groups of formula (IX) and salts thereof:

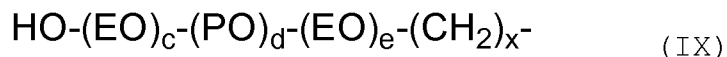

[00093] wherein: c, d, and e, which may be identical or different, are each integers ranging from 0 to 20; and x is an integer ranging from 0 to 21; and groups of formula (X) and
20 salts thereof:

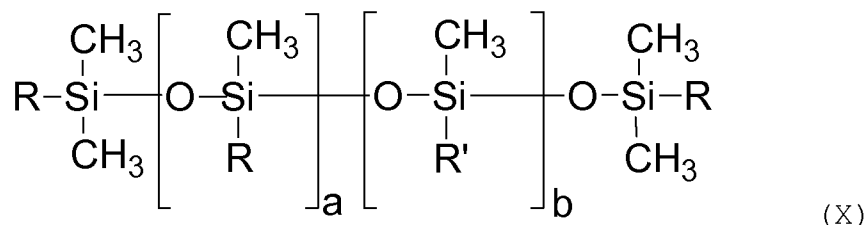

[00094] wherein: a is an integer ranging from 0 to 200; b is an integer ranging from 0 to 200; R' , which may be identical or different, are each chosen from optionally substituted
25 hydrocarbons, such as alkyl groups and alkenyl groups comprising from 1 to 22 carbon atoms, optionally substituted aromatic groups, groups of formula (IX) as defined above and salts thereof; and R, which may be identical or different, are

each chosen from optionally substituted hydrocarbons, such as alkyl groups and alkenyl groups comprising from 1 to 22 carbon atoms, optionally substituted aromatic groups, optionally substituted divalent hydrocarbons, such as alkylene groups and alkenylene groups comprising from 1 to 22 carbon atoms, optionally substituted divalent aromatic groups, groups of formula (IX) as defined above and salts thereof, and groups of formula (XI):

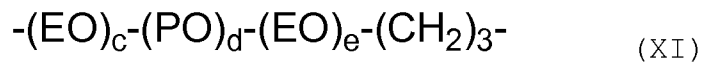

10 wherein:

[00095] the $(\text{CH}_2)_3$ end is bonded to the silicon of the compound of formula (X) and the (EO) or (PO) end, if present, is bonded to the oxygen of the compound of formula (VII); c, d, and e, which may be identical or different, are each integers ranging from 0 to 20; EO is an ethylene oxide group; and PO is a propylene oxide group; and with the proviso that at least one R is chosen from groups of formula (XI) and salts thereof; and with the further proviso that at least one R^1 is chosen from groups of formula (X) and salts thereof and at least one other R^1 is chosen from H, organic cations, and inorganic cations.

[00096] Non-limiting examples of the inorganic cations include alkali metals, such as potassium, lithium, and sodium. Non-limiting examples of the at least one silicone compound include those commercially available from Phoenix Chemical, Inc. of New Jersey under the name of Pecosil®, such as Pecosil® PS-100, Pecosil® PS-112, Pecosil® PS-150, Pecosil® PS-200, Pecosil® WDS-100, Pecosil® WDS-200, Pecosil® PS-100 B, and Pecosil® PS-100 K and those commercially available from Siltech under the name Silphos A-100 and Silphos A-150. Other non-limiting examples of the at least one silicone compound include those described in U.S. Patent Nos. 5,070,171, 5,093,452, and 5,149,765 the disclosures of which are

incorporated herein by reference.

[00097] Suitable silicone sulfates for use in the present invention include those represented by formula XII:

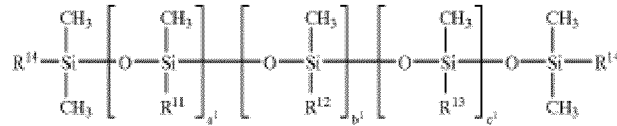

(XII)

5 [00098] wherein R¹¹ is selected from lower alkyl having one to eight carbon atoms or phenyl, R¹² is --(CH₂)₃--O--(EO)_x--(PO)_y--(EO)_z--SO₃³¹--M⁺ wherein M is a cation and is selected from Na, K, Li, or NH₄; x, y and z are integers independently ranging from 0 to 100; R¹³ is --(CH₂)₃--O--(EO)_x--(PO)_y--(EO)_z--H
 10 ; R¹⁴ is methyl or hydroxyl; a¹ and c¹ are independently integers ranging from 0 to 50; b¹ is an integer ranging from 1 to 50. An example thereof is Ultrasil SA-1 silicone commercially available from Noveon.

[00099] Suitable silicone sulfosuccinates which may be
 15 employed include, but are not limited to, those corresponding to formula XIII:

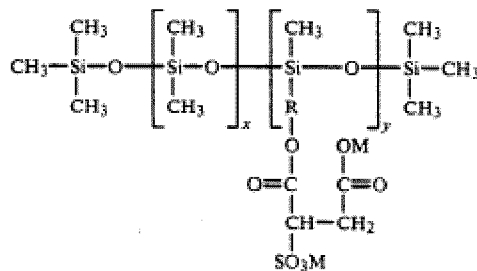

(XIII)

[000100] wherein R represents a divalent radical selected from

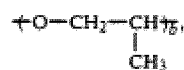

and

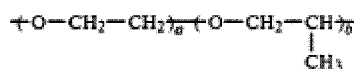

[000101] wherein a' and b' range from 0 to 30; x and y are such that the molecular weight ranges from 700 to 1600, and M is an alkali metal such as sodium or potassium, or an ammonium group.

5 [000102] A particularly preferred anionic silicone is Dimethicone PEG-7 phosphate, commercially available from Phoenix Chemical under the tradenames Pecosil® PS-100 and Pecosil® PS-112, and from Lubrizol Advanced Materials, Inc. under the tradename Silsense® PE-100L Silicone. Another
10 particularly preferred anionic silicone is Dimethicone PEG-8 phosphate, commercially available from Lubrizol Advanced Materials, Inc. under the tradename Silsense® PE-100 Silicone.

[000103] Preferably, the anionic silicone are chosen from silicone carboxylate, silicone phosphate, silicone sulfate,
15 silicone sulfosuccinate and silicone sulfonate.

[000104] In one embodiment, anionic silicone is a silicone phosphate.

[000105] In one embodiment, anionic silicone is a silicone carboxylate.

20 [000106] In one embodiment, anionic silicone is a silicone sulfate.

[000107] The anionic silicone is present in the composition in an amount ranging from greater than 0% to about 50% by weight, preferably from about 0.1% to about 30% by weight, and
25 more preferably from about 0.5% to about 20% by weight, based on the weight of the composition as a whole.

DYE COMPOUNDS

[000108] The dye compounds of the present disclosure may be
30 chosen from oxidation bases, couplers, and direct dyes.

OXIDATION BASES

[000109] Examples of oxidation bases include ortho or para

aminophenols, ortho or para phenylenediamines, double bases, heterocyclic bases, and the acid addition salts thereof.

[000110] The para-phenylenediamines which can be used include compounds of the following formula (A) and their addition salts with an acid :

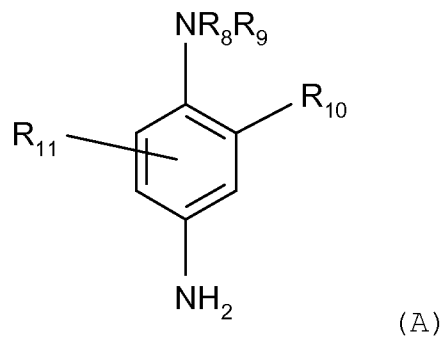

in which :

[000111] R_8 represents a hydrogen atom, a C_1 - C_4 alkyl radical, a C_1 - C_4 monohydroxyalkyl radical, a C_2 - C_4 polyhydroxyalkyl radical, a $(\text{C}_1$ - C_4)alkoxy(C_1 - C_4)alkyl radical, a C_1 - C_4 alkyl radical substituted by a nitrogenous group, a phenyl radical or a 4'-aminophenyl radical ;

[000112] R_9 represents a hydrogen atom, a C_1 - C_4 alkyl radical, a C_1 - C_4 monohydroxyalkyl radical, a C_2 - C_4 polyhydroxyalkyl radical, a $(\text{C}_1$ - C_4)alkoxy(C_1 - C_4)alkyl radical or a C_1 - C_4 radical substituted by a nitrogenous group;

[000113] R_8 and R_9 can also form, with the nitrogen atom which carries them, a 5- or 6-membered nitrogenous heterocycle optionally substituted by one or more alkyl, hydroxyl or ureido groups;

[000114] R_{10} represents a hydrogen atom, a halogen atom, such as a chlorine atom, a C_1 - C_4 alkyl radical, a sulpho radical, a carboxyl radical, a C_1 - C_4 monohydroxyalkyl radical, a C_1 - C_4 hydroxyalkoxy radical, a C_1 - C_4 acetylaminoalkoxy radical, a C_1 - C_4 mesylaminoalkoxy radical or C_1 - C_4 carbamoylaminoalkoxy radicals;

[000115] R_{11} represents a hydrogen atom, a halogen atom or a C_1 - C_4 alkyl radical.

[000116] The nitrogenous groups in the above formula (A) include amino, mono(C₁-C₄)alkylamino, di(C₁-C₄)alkylamino, tri(C₁-C₄)alkylamino, monohydroxy(C₁-C₄)alkylamino, imidazolium and ammonium radicals.

5 [000117] The para-phenylenediamines of above formula (A) include para-phenylenediamine, para-toluylenediamine, 2-chloro-para-phenylenediamine, 2,3-dimethyl-para-phenylenediamine, 2,6-dimethyl-para-phenylenediamine, 2,6-diethyl-para-phenylenediamine, 2,5-dimethyl-para-phenylenediamine, N,N-dimethyl-para-phenylenediamine, N,N-diethyl-para-phenylenediamine, N,N-dipropyl-para-phenylenediamine, 4-amino-N,N-diethyl-3-methylaniline, N,N-bis(β-hydroxyethyl)-para-phenylenediamine, 4-N,N-bis(β-hydroxyethyl)amino-2-methylaniline, 4-N,N-bis(β-hydroxyethyl)amino-2-chloroaniline, 2-(β-hydroxyethyl)-para-phenylenediamine, 2-fluoro-para-phenylenediamine, 2-isopropyl-para-phenylenediamine, N-(β-hydroxypropyl)-para-phenylenediamine, 2-hydroxymethyl-para-phenylenediamine, N,N-dimethyl-3-methyl-para-phenylenediamine, N-ethyl-N-(β-hydroxyethyl)-para-phenylenediamine, N-(β,γ-dihydroxypropyl)-para-phenylenediamine, N-(4'-aminophenyl)-para-phenylenediamine, N-phenyl-para-phenylenediamine, 2-(β-hydroxyethyloxy)-para-phenylenediamine, 2-(β-acetylaminoethyloxy)-para-phenylenediamine, N-(β-methoxyethyl)-para-phenylenediamine, 2-methyl-1-N-(β-hydroxyethyl)-para-phenylenediamine and their addition salts with an acid.

[000118] In one embodiment, the para-phenylenediamines of above formula (A) include para-phenylenediamine, para-toluylenediamine, 2-isopropyl-para-phenylenediamine, 2-(β-hydroxyethyl)-para-phenylenediamine, 2-(β-hydroxyethyloxy)-para-phenylenediamine, 2,6-dimethyl-para-phenylenediamine, 2,6-diethyl-para-phenylenediamine, 2,3-dimethyl-para-

phenylenediamine, *N,N*-bis(β -hydroxyethyl)-*para*-phenylenediamine, 2-chloro-*para*-phenylenediamine and their addition salts with an acid.

[000119] The *ortho*-phenylenediamines include *N*1-(2-
 5 hydroxyethyl)-4-nitro-*o*-phenylenediamine, 4-methyl-*o*-phenylenediamine, and 4-nitro-*o*-phenylenediamine and acid addition salts thereof.

[000120] As used herein, the term "double bases" means compounds comprising at least two aromatic nuclei having at
 10 least one of amino and hydroxyl groups.

[000121] Examples include compounds corresponding to the following formula (B) and their addition salts with an acid:

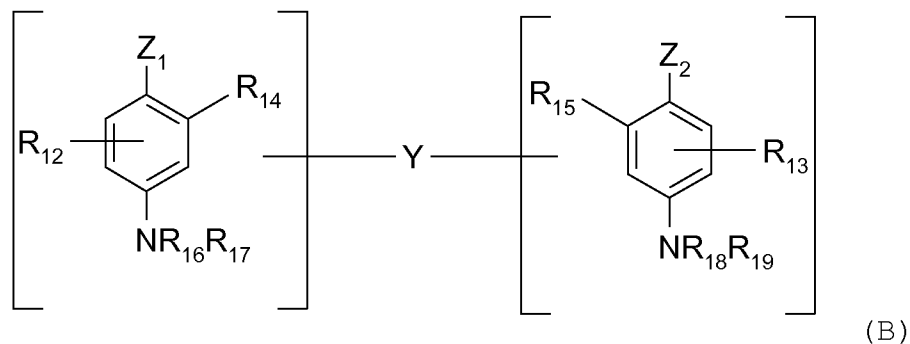

in which:

15 [000122] Z_1 and Z_2 , which are identical or different, represent a hydroxyl or $-NH_2$ radical which can be substituted by a C_1 - C_4 alkyl radical or by a connecting arm Y;

[000123] the connecting arm Y represents a linear or branched alkylene chain comprising from 1 to 14 carbon atoms which can
 20 be interrupted or terminated by one or more nitrogenous groups and/or by one or more heteroatoms, such as oxygen, sulphur or nitrogen atoms, and which is optionally substituted by one or more hydroxyl or C_1 - C_6 alkoxy radicals;

[000124] R_{12} and R_{13} represent a hydrogen or halogen atom, a
 25 C_1 - C_4 alkyl radical, a C_1 - C_4 monohydroxyalkyl radical, a C_2 - C_4 polyhydroxyalkyl radical, a C_1 - C_4 aminoalkyl radical or a connecting arm Y;

[000125] R_{14} , R_{15} , R_{16} , R_{17} , R_{18} and R_{19} , which are identical or different, represent a hydrogen atom, a connecting arm Y or a C_1 - C_4 alkyl radical;

[000126] it is being understood that the compounds of formula (B) only comprise a single connecting arm Y per molecule.

[000127] Nitrogenous groups of the above formula (B) include amino, mono(C_1 - C_4)alkylamino, di(C_1 - C_4)alkylamino, tri(C_1 - C_4)alkylamino, monohydroxy(C_1 - C_4)alkylamino, imidazolinium and ammonium radicals.

[000128] Additional examples of double bases of above formula (B) include of N,N' -bis(β -hydroxyethyl)- N,N' -bis(4'-aminophenyl)-1,3-diamino-propanol, N,N' -bis(β -hydroxyethyl)- N,N' -bis(4'-aminophenyl)ethylenediamine, N,N' -bis(4-aminophenyl)-tetramethylenediamine, N,N' -bis(β -hydroxyethyl)- N,N' -bis(4-aminophenyl)tetramethylenediamine, N,N' -bis(4-methylaminophenyl)tetramethylenediamine, N,N' -diethyl- N,N' -bis(4'-amino-3'-methylphenyl)ethylenediamine, 1,8-bis(2,5-diaminophenoxy)-3,5-dioxaoctane and their addition salts with an acid.

[000129] In one embodiment the double base is N,N' -Bis(β -hydroxyethyl)- N,N' -bis(4'-aminophenyl)-1,3-diaminopropanol, 1,8-bis(2,5-diaminophenoxy)-3,5-dioxaoctane or one of their addition salts with an acid.

[000130] The para-aminophenols which can be used include compounds of the following formula (C) and their addition salts with an acid:

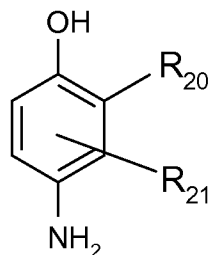

in which:

[000131] R_{20} represents a hydrogen atom, a halogen atom, such

as fluorine, a C₁-C₄ alkyl radical, a C₁-C₄ monohydroxyalkyl radical, a (C₁-C₄)alkoxy(C₁-C₄) alkyl radical, a C₁-C₄ aminoalkyl radical or a hydroxy(C₁-C₄)alkylamino-(C₁-C₄)alkyl radical,

5 [000132] R₂₁ represents a hydrogen atom, a halogen atom, such as fluorine, a C₁-C₄ alkyl radical, a C₁-C₄ monohydroxyalkyl radical, a C₂-C₄ polyhydroxyalkyl radical, a C₁-C₄ aminoalkyl radical, a C₁-C₄ cyanoalkyl radical or a (C₁-C₄)alkoxy(C₁-C₄)alkyl radical.

10 [000133] Among the para-aminophenols, mention may be made of para-aminophenol, 4-amino-3-methylphenol, 4-amino-3-fluorophenol, 4-amino-3-hydroxymethylphenol, 4-amino-2-methylphenol, 4-amino-2-hydroxymethyl phenol, 4-amino-2-methoxymethylphenol, 4-amino-2-aminomethylphenol, 4-amino-2-
15 (β-hydroxyethylaminomethyl)phenol, N-methyl-para-aminophenol, and the acid addition salts thereof.

[000134] The ortho-aminophenols that may be used as oxidation bases in the context of certain embodiments may be chosen from 2-aminophenol, 2-amino-1-hydroxy-5-methylbenzene, 2-amino-1-
20 hydroxy-6-methylbenzene, 5-acetamido-2-aminophenol, and the acid addition salts thereof.

[000135] Heterocyclic bases that can be used as oxidation bases in the methods of coloring keratinous substrates include pyridine derivatives, pyrimidine derivatives, pyrazole
25 derivatives, pyrazolinone derivatives, and the acid addition salts thereof.

[000136] Pyridine derivatives include the compounds described, for example, in patents GB 1,026,978 and GB 1,153,196, as well as the compounds 2,5-diaminopyridine, 2-(4-
30 methoxyphenyl)amino-3-aminopyridine, 2,3-diamino-6-methoxypyridine, 2-(β-methoxyethyl)amino-3-amino-6-methoxypyridine, 3,4-diaminopyridine, and the acid addition salts thereof.

[000137] Pyrimidine derivatives include the compounds disclosed, for example, in German Patent DE 2 359 399 or Japanese Patents JP 88-169 571 and JP 91-10659 or Patent Application WO 96/15765, such as 2,4,5,6-tetra-
5 aminopyrimidine, 4-hydroxy-2,5,6-triaminopyrimidine, 2-hydroxy-4,5,6-triamino-pyrimidine, 2,4-dihydroxy-5,6-diaminopyrimidine, 2,5,6-triaminopyrimidine, and the pyrazolopyrimidine derivatives, such as those mentioned in French Application FR-A-2 750 048 and among which may be
10 mentioned pyrazolo[1,5-a]pyrimidine-3,7-diamine; 2,5-dimethylpyrazolo[1,5-a]pyrimidine-3,7-diamine; pyrazolo[1,5-a]pyrimidine-3,5-diamine; 2,7-dimethylpyrazolo[1,5-a]pyrimidine-3,5-diamine; 3-aminopyrazolo[1,5-a]pyrimidin-7-ol; 3-aminopyrazolo[1,5-a]pyrimidin-5-ol; 2-(3-
15 aminopyrazolo[1,5-a]pyrimidin-7-ylamino)ethanol; 2-(7-aminopyrazolo[1,5-a]pyrimidin-3-ylamino)ethanol; 2-[(3-aminopyrazolo[1,5-a]pyrimidin-7-yl)(2-hydroxyethyl)amino]ethanol; 2-[(7-aminopyrazolo[1,5-a]pyrimidin-3-yl)(2-hydroxyethyl)amino]ethanol; 5,6-dimethyl-
20 pyrazolo[1,5-a]pyrimidine-3,7-diamine; 2,6-dimethylpyrazolo[1,5-a]pyrimidine-3,7-diamine; 2,5,N7,N7-tetramethylpyrazolo[1,5-a]pyrimidine-3,7-diamine; 3-amino-5-methyl-7-(imidazolylpropylamino)pyrazolo[1,5-a]pyrimidine; and their addition salts and their tautomeric forms, when there
25 exists a tautomeric equilibrium, and their addition salts with an acid.

[000138] Pyrazole and pyrazolinone derivatives include the compounds described in patents DE 3,843,892, DE 4,133,957 and patent applications WO 94/08969, WO 94/08970, FR-A-2,733,749,
30 and DE 195 43 988, such as 4,5-diamino-1-methyl-pyrazole, 3,4-diaminopyrazole, 4,5-diamino-1-(4'-chlorobenzyl)pyrazole, 4,5-diamino-1,3-dimethylpyrazole, 4,5-diamino-3-methyl-1-phenylpyrazole, 4,5-diamino-1-methyl-3-phenylpyrazole, 4-

amino-1, 3-dimethyl-5-hydrazinopyrazole, 1-benzyl-4,5-diamino-3-methylpyrazole, 4, 5-diamino-3-tert-butyl-1-methylpyrazole, 4,5-diamino-1-tert-butyl-3- methylpyrazole, 4,5-diamino-1-(β -hydroxyethyl)-3- methylpyrazole, 4,5-diamino-1-(β -hydroxyethyl)pyrazole, 4,5-diamino-1-ethyl-3-methylpyrazole, 4,5-diamino-1-ethyl-3-(4'-methoxyphenyl) pyrazole, 4,5-diamino-1-ethyl-3-hydroxymethylpyrazole, 4,5-diamino-3-hydroxymethyl-1- methylpyrazole, 4,5-diamino-3-hydroxymethyl-1-isopropylpyrazole, 4,5-diamino-3-methyl-1-isopropylpyrazole, 4-amino-5-(2'-aminoethyl) amino-1,3-dimethyl-pyrazole, 3,4,5-triaminopyrazole, 1- methyl-3,4,5- triaminopyrazole, 3,5-diamino-1-methyl-4- methylaminopyrazole, 3,5-diamino-4-(β -hydroxyethyl)amino-1- methylpyrazole, 2-(4,5-diamino-1H-pyrazol-1-yl), H₂SO₄, 2,3-diamino-6,7-dihydro-1H,5H-pyrazolo[1,2-z]pyrazol-1-one, 1-methyl-3-phenyl-2-pyrazolinone, and the acid addition salts thereof.

[000139] Even further non-limiting mentions can be made of 2,3-diamino-6,7-dihydro-1H,5H-pyrazolo[1,2-a]pyrazol-1-one and/or addition salts thereof.

[000140] As heterocyclic bases, further non-limiting mentions can be made of 4,5-diamino-1-(β -hydroxyethyl)pyrazole and/or 2,3-diamino-6,7-dihydro-1H,5H-pyrazolo[1,2-a]pyrazol-1-one and/or addition salts thereof.

[000141] As cationic oxidation bases usable in the compositions according to the disclosure, non-limiting mentions can be made of the following compounds: the paraphenylenediamines for example as described in French Patent Application Nos. 2 766 177 and 2 766 178, the paraaminophenols as described for example in French Patent Application Nos. 2 766 177 and 2 766 178, the orthophenylenediamines as described for example in French Patent Application Nos. 2 782 718, 2 782 716 and 2 782 719, the ortho-aminophenols or cationic double bases such as

derivatives of the bis(aminophenyl)alkylenediamine type described in French Patent Application No. 2 766 179, as well as the cationic heterocyclic bases, the compounds bearing at least one quaternary nitrogen atom.

5 [000142] For example, the cationic oxidation bases usable in the compositions according to the disclosure are cationic para-phenylenediamines. For example, in some embodiments cationic oxidation bases of para-phenylenediamine structure can be used, wherein at least one of the amine functions is a
10 tertiary amine bearing a pyrrolidine nucleus, the molecule possessing at least one quaternized nitrogen atom. Such bases are described, for example, in European Patent Application Publication No. 1 348 695.

[000143] The oxidation bases may be employed in amounts
15 ranging from about 0.0001% to about 12% by weight, or from about 0.1% to about 8.0% by weight, or from about 1% to about 5% by weight, based on the total weight of the composition.

COUPLER COMPOUNDS

20 [000144] The compositions of the present disclosure may also contain coupler compounds. The couplers that may be used in the dyeing method disclosed herein include those conventionally used in oxidative methods of coloring keratinous fibers, for example, meta-aminophenols, meta-
25 phenylenediamines and meta-diphenols, naphthols, mono- or polyhydroxylated naphthalene derivatives, and heterocyclic couplers such as, for example, indole derivatives, indoline derivatives, sesamol and its derivatives, pyridine derivatives, pyrazolotriazole derivatives, pyrazolones,
30 indazoles, benzimidazoles, benzothiazoles, benzoxazoles, 1,3-benzodioxoles, quinolines, benzomorpholine derivatives, pyrazoloazole derivatives, pyrroloazole derivatives, imidazoloazole derivatives, pyrazolopyrimidine derivatives,

pyrazoline-3,5-dione derivatives, pyrrolo[3,2-d]oxazole derivatives, pyrazolo[3,4-d]thiazole derivatives, thiazoloazole S-oxide derivatives, thiazoloazole S,S-dioxide derivatives, and the acid addition salts thereof.

5 [000145] Suitable color couplers include, for example, those having the general formula (D):

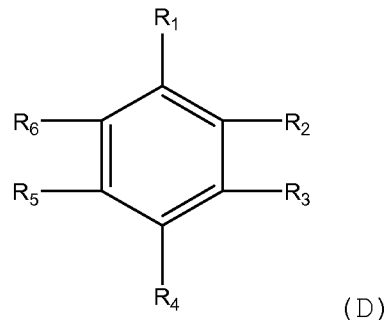

[000146] wherein R_1 is unsubstituted hydroxy or amino, or hydroxy or amino substituted with one or more C_{1-6} hydroxyalkyl groups, R_3 and R_5 are each independently hydrogen, hydroxy, amino, or amino substituted with C_{1-6} alkyl, C_{1-6} alkoxy, or C_{1-6} hydroxyalkyl group; and R_2 , R_4 , and R_6 are each independently hydrogen, C_{1-6} alkoxy, C_{1-6} hydroxyalkyl, or C_{1-6} alkyl, or R_3 and R_4 together may form a methylenedioxy or ethylenedioxy group.

10 Examples of such compounds include meta-derivatives such as phenols, meta-aminophenols, meta-phenylenediamines, and the like, which may be unsubstituted, or substituted on the amino group or benzene ring with alkyl, hydroxyalkyl, alkylamino groups, and the like. Suitable couplers include m-aminophenol,

15 2,4-diaminotoluene, 4-amino, 2-hydroxytoluene, phenyl methyl pyrazolone, 3,4-methylenedioxyphenol, 3,4-methylenedioxy-1-[(β -hydroxyethyl)amino]benzene, 1-methoxy-2-amino-4-[(β -hydroxyethyl)amino]benzene, 1-hydroxy-3-(dimethylamino)benzene, 6-methyl-1-hydroxy-3-[(β -hydroxyethyl)amino]benzene,

20 2,4-dichloro-1-hydroxy-3-aminobenzene, 1-hydroxy-3-(diethylamino)benzene, 1-hydroxy-2-methyl-3-aminobenzene, 2-chloro-6-methyl-1-hydroxy-3-aminobenzene, 1,3-diaminobenzene, 6-methoxy-1,3-

diaminobenzene, 6-hydroxyethoxy-1,3-diaminobenzene, 6-methoxy-5-ethyl-1,3-diaminobenzene, 6-ethoxy-1,3-diaminobenzene, 1-bis(β -hydroxyethyl)amino-3-aminobenzene, 2-methyl-1,3-diaminobenzene, 6-methoxy-1-amino-3-[(β -hydroxyethyl)amino]-benzene, 6-(β -aminoethoxy)-1,3-diaminobenzene, 6-(β -hydroxyethoxy)-1-amino-3-(methylamino)benzene, 6-carboxymethoxy-1,3-diaminobenzene, 6-ethoxy-1-bis(β -hydroxyethyl)amino-3-aminobenzene, 6-hydroxyethyl-1,3-diaminobenzene, 1-hydroxy-2-isopropyl-5-methylbenzene, 1,3-dihydroxybenzene, 2-chloro-1,3-dihydroxybenzene, 2-methyl-1,3-dihydroxybenzene, 4-chloro-1,3-dihydroxybenzene, 5,6-dichloro-2-methyl-1,3-dihydroxybenzene, 1-hydroxy-3-amino-benzene, 1-hydroxy-3-(carbamoylmethylamino)benzene, 6-hydroxybenzomorpholine, 4-methyl-2,6-dihydroxypyridine, 2,6-dihydroxypyridine, 2,6-diaminopyridine, 6-aminobenzomorpholine, 1-phenyl-3-methyl-5-pyrazolone, 1-hydroxynaphthalene, 1,7-dihydroxynaphthalene, 1,5-dihydroxynaphthalene, 5-amino-2-methyl phenol, 4-hydroxyindole, 4-hydroxyindoline, 6-hydroxyindole, 6-hydroxyindoline, 2,4-diamionphenoxyethanol, and mixtures thereof.

[000147] Other couplers may be chosen, for example, from 2,4-diamino-1-(β -hydroxyethoxy)benzene, 2-methyl-5-aminophenol, 5-N-(β -hydroxyethyl) amino-2-methylphenol, 3-aminophenol, 1,3-dihydroxybenzene, 1,3-dihydroxy-2-methylbenzene, 4-chloro-1,3-dihydroxybenzene, 2,4-diamino 1-(β -hydroxyethoxy) benzene, 2-amino-4-(β -hydroxyethylamino)-1-methoxybenzene, 1,3-diaminobenzene, 1,3-bis(2,4-diaminophenoxy)propane, sesamol, 1-amino-2-methoxy-4,5-methylenedioxybenzene, α -naphthol, 6-hydroxyindole, 4-hydroxyindole, 4-hydroxy-N-methylindole, 6-hydroxyindoline, 2,6-dihydroxy-4-methylpyridine, 1H-3-methylpyrazol-5-one, 1-phenyl-3-methylpyrazol-5-one, 2-amino-3-hydroxypyridine, 3,6-

dimethylpyrazolo[3,2-c]-1,2,4-triazole, 2, 6-dimethylpyrazolo[1,5-b]-1,2,4-triazole, 6-methyl pyrazolo[1,5-a]-benzimidazole, and the acid addition salts thereof.

[000148] In one embodiment, the couplers include resorcinol, 5 1-naphthol, 2-methylresorcinol, 4-amino-2-hydroxy toluene, m-aminophenol, 2,4-diaminophenoxyethanol, phenyl methyl pyrazolone, hydroxybenzomorpholine, 2-methyl-5-hydroxyetylamino-phenol, 6-hydroxyindole, 2-amino-3-hydroxypyridine, 5-amino-6-chloro-o-cresol, 4-10 chlororesorcinol, their salts, and mixtures thereof.

[000149] When they are present, couplers may be present in amounts ranging from about 0.0001% to about 12% by weight; or from about 0.1% to about 8% by weight; or from about 1% to about 5% based on the total weight of the composition.

15 [000150] In general, the acid addition salts of the oxidation bases and couplers may be chosen from hydrochlorides, hydrobromides, sulphates, tartrates, lactates, and acetates.

DIRECT DYES

20 [000151] A direct dye is a colored substance that does not require the use of an oxidizing agent in order to reveal its color. Suitable direct dyes which may be used according to the present invention may be chosen from acidic (anionic), basic (cationic), and neutral dyes.

25 [000152] "Acidic dye" is generally intended to mean a dye containing at least one COOH, SO₃H, PO₃H, or PO₄H₂ group, it being possible for said groups to exist in the form of salts. "Salts" is generally intended to mean salts of metals (for example, alkali metals or alkaline earth metals), salts of an30 organic amine that is optionally hydroxylated. Such dyes are also referred to as anionic dyes.

[000153] The acidic dyes that can be used in the context of this invention can be chosen from acidic nitro dyes, acidic

azo dyes, acidic azine dyes, acidic triarylmethane dyes, acidic quinone dyes, acidic indo-amine dyes and acidic natural dyes, and mixtures thereof.

[000154] "Basic dyes" is generally intended to mean a dye
5 that has at least one group bearing a positive charge, such as an ammonium group or a quaternized nitrogen atom in a ring. Such dyes are also referred to as cationic dyes.

[000155] The basic dyes that can be used in the context of this invention can be chosen from nitrobenzene dyes, azo dyes,
10 azomethine dyes, methine dyes, tetraazapentamethine dyes, anthraquinone dyes, naphthoquinone dyes, benzoquinone dyes, phenothiazine dyes, indigoid dyes, xanthene dyes, phenanthridine dyes, phthalocyanin dyes, triarylamethane-derived dyes and basic natural dyes, and mixtures thereof.

[000156] Preferably, the direct dyes may be present in
15 amounts ranging from about 0.001% to about 30% by weight, preferably from about 0.01% to about 20% by weight, more preferably from about 0.1% to about 10% by weight, and even more preferably from about 1% to about 5% by weight, based on
20 the total weight of the composition.

THICKENING AGENT

[000157] The composition of the present invention may further comprise at least one thickening agent.

[000158] The aqueous composition of the present invention
25 may further comprise at least one thickening agent.

[000159] Thickening agents of the present invention may be chosen from polymeric thickeners and non-polymeric thickeners as described in US2010154140A, herein incorporated by
30 reference in its entirety.

[000160] Thickening agents of the present invention may be chosen from polymeric thickeners and non-polymeric thickeners. The at least one polymeric thickener can be ionic or non-ionic,

associative or non-associative polymer. Exemplary polymeric thickeners include various native gums. Representative non-polymeric thickening agents include mineral salts such as sodium chloride; oxyethylenated molecules and especially
5 ethoxylated alkyl or acyl derivatives of polyols. These polymers can be modified physically or chemically.

[000161] In the present invention, the thickening agent is preferably used in an amount of from greater than 0% to about 15% by weight, particularly about 0.01 to about 10% by weight,
10 preferably 0.1% to 10% by weight, and more preferably from about 0.5% to about 5% by weight, and even more preferably from about 1% to about 4% by weight, based on the total weight of the composition.

15 ALKALINE AGENTS

[000162] The composition of the present invention may further comprise at least one alkaline agent.

[000163] The at least one alkaline agent of the present invention may be chosen from organic amines, organic amine
20 salts, ammonium salts, and inorganic bases.

[000164] The organic amines may be chosen from the ones having a pK_b at 25°C of less than 12, such as less than 10 or such as less than 6. It should be noted that this is the pK_b corresponding to the function of highest basicity.

25 [000165] Organic amines may be chosen from organic amines comprising one or two primary, secondary, or tertiary amine functions, and at least one linear or branched C₁-C₈ alkyl groups bearing at least one hydroxyl radical.

[000166] Organic amines may also be chosen from alkanolamines
30 such as mono-, di- or trialkanolamines, comprising one to three identical or different C₁-C₄ hydroxyalkyl radicals, ethylamines, ethyleneamines, quinoline, aniline and cyclic amines, such as pyrrolone, pyrrole, pyrrolidine, imidazole,

imidazolidine, imidazolidinine, morpholine, pyridine, piperidine, pyrimidine, piperazine, triazine and derivatives thereof.

[000167] Among the compounds of the alkanolamine type that
5 may be mentioned include but not limited to: monoethanolamine, diethanolamine, triethanolamine, monoisopropanolamine, diisopropanolamine, N-dimethylaminoethanolamine, 2-amino-2-methyl-1-propanol, triisopropanolamine, 2-amino-2-methyl-1,3-propanediol, 3-amino-1,2-propanediol, 3-dimethylamino-1,2-
10 propanediol, and tris(hydroxymethylamino)methane.

[000168] The organic amines correspond to formula XIV:

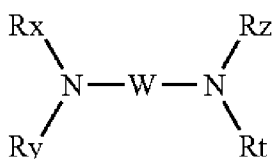

(XIV)

[000169] wherein W is chosen from C₁-C₆ alkylene residues optionally substituted with a hydroxyl group or a C₁-C₆ alkyl
15 radical; Rx, Ry, Rz and Rt, which may be identical or different, are chosen from a hydrogen atom, C₁-C₆ alkyl radicals, C₁-C₆ hydroxyalkyl radicals, and C₁-C₆ aminoalkyl radicals.

[000170] Examples of such amines that may be mentioned
20 include but not limited to: 1,3-diaminopropane, 1,3-diamino-2-propanol, spermine, and spermidine.

[000171] In some embodiments, the organic amines are chosen from amino acids.

[000172] As non-limiting examples, the amino acids that may
25 be used may be of natural or synthetic origin, in L, D, or racemic form, and comprise at least one acid function chosen from, for instance, carboxylic acid, sulfonic acid, phosphonic acid, and phosphoric acid functions. The amino acids may be in their neutral or ionic form.

[000173] Further as non-limiting examples, the amino acids may be chosen from basic amino acids comprising an additional amine function optionally included in a ring or in a ureido function.

5 [000174] Such basic amino acids may be chosen from those corresponding to formula (E) below:

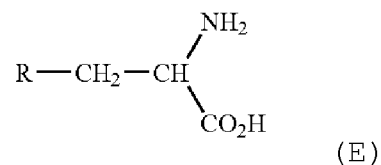

[000175] wherein R is a group chosen from:

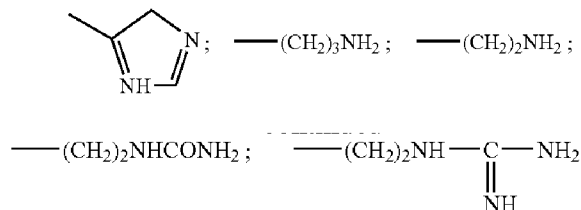

10

[000176] The compounds corresponding to formula (E) may be chosen from histidine, lysine, arginine, ornithine, and citrulline.

[000177] Amino acids that may be used in the present
15 disclosure include but not limited to: aspartic acid, glutamic acid, alanine, arginine, ornithine, citrulline, asparagine, carnitine, cysteine, glutamine, glycine, histidine, lysine, isoleucine, leucine, methionine, N-phenylalanine, proline, serine, taurine, threonine, tryptophan, tyrosine, and valine.

20 [000178] In some embodiments, the organic amines are chosen from basic amino acids. The amino acids may be chosen from, for instance, arginine, lysine and histidine, or mixtures thereof.

[000179] In some embodiments, the organic amines are chosen
25 from organic amines of heterocyclic type. Besides histidine that has already been mentioned in the amino acids, non-

limiting mention may also be made of pyridine, piperidine, imidazole, 1,2,4-triazole, tetrazole, and benzimidazole.

[000180] In some embodiments, the organic amines are chosen from amino acid dipeptides. Amino acid dipeptides that may be
5 used in the present disclosure include but not limited to: carnosine, anserine, and baleine.

[000181] In some embodiments, the organic amines are chosen from compounds comprising a guanidine function. Organic amines of this type that may be used in the present disclosure
10 include, besides arginine that has already been mentioned as an amino acid, creatine, creatinine, 1,1-dimethylguanidine, 1,1-diethylguanidine, glycoamine, metformin, agmatine, N-amidinoalanine, 3-guanidinopropionic acid, 4-guanidinobutyric acid, and 2-([amino(imino)methyl]amino)ethane-1-sulfonic acid.

[000182] As a non-limiting example, the organic amines are
15 chosen from alkanolamines. For example, the organic amines are chosen from 2-amino-2-methyl-1-propanol and monoethanolamine, or mixtures thereof. Further as an example, the organic amine is monoethanolamine.

[000183] The alkaline agent may be an organic amine in salt
20 form. The term "organic amine salt," as used herein, means organic or mineral salts of an organic amine as described above.

[000184] As a non-limiting example, the organic salts may be
25 chosen from the salts of organic acids, such as citrates, lactates, glycolates, gluconates, acetates, propionates, fumarates, oxalates and tartrates.

[000185] Further as a non-limiting example, the mineral salts
30 may be chosen from hydrohalides (for example hydrochlorides), carbonates, hydrogen carbonates, sulfates, hydrogen phosphates, and phosphates.

[000186] The ammonium salts that may be used in the composition according to the present disclosure may be chosen

from the following acid salts: carbonate, bicarbonate. For instance, the salt is the carbonate, such as ammonium carbonate.

[000187] The inorganic bases that may be used in the composition according to the present disclosure may be chosen from alkali metal phosphates and carbonates such as, for example, sodium phosphate, potassium phosphate, sodium carbonate, sodium bicarbonate, potassium carbonate, potassium bicarbonate, and their derivatives.

[000188] The inorganic bases may also include alkali metals of carboxylates such as, for example, sodium acetate, potassium acetate, sodium citrate, and potassium citrate, and their derivatives.

[000189] According to one embodiment, the dyeing composition of the present invention comprises an alkaline agent chosen from at least one organic amine such as at least one alkanolamine. When the composition comprises more than one alkaline agents including an alkanolamine and ammoniumhydroxides or salts thereof, the amount of organic amine(s) are for example higher than the amount of ammonia.

[000190] According to another embodiment, the dyeing composition of the present invention is substantially free of ammonia. The term "substantially free of ammonia" means that the composition of the present invention is either completely free of ammonia (including ammonium ions) or contains no appreciable amount of ammonia (including ammonium ions), for example, no more than 1% by weight, or no more than 0.5% by weight, or no more than 0.3% by weight, or no more than 0.1% by weight, based on the weight of the composition. According to this embodiment, the dyeing composition, for example, contains at least one alkanolamine such as monoethanolamine.

[000191] The at least one alkaline agent may be employed in the composition of the present invention in an amount ranging

from 0.001% to about 30% by weight, such as from about 0.01% to about 20% by weight or from 0.1% to 15% by weight, or from about 1% to about 10% by weight, based on the total weight of the composition.

5

FATTY SUBSTANCE

[000192] The composition of the present invention may further comprise at least one fatty substance other than a fatty acid.

[000193] "Fatty substance" means an organic compound
10 insoluble in water at normal temperature (25°C) and at atmospheric pressure (760 mmHg) (solubility below 5% and such as below 1% and further such as below 0.1%). Fatty substances have in their structure a chain of at least two siloxane groups or at least one hydrocarbon chain having at least 6
15 carbon atoms. Moreover, fatty substances are generally soluble in organic solvents in the same conditions of temperature and pressure, for example in chloroform, ethanol, benzene or decamethylcyclopentasiloxane.

[000194] The composition of the present invention comprises
20 at least 10% of fatty substances by weight relative to the total weight of the composition, these substances being other than fatty acid.

[000195] Fatty substances are, for example, chosen from lower alkanes, fatty alcohols, esters of fatty acid, esters of fatty
25 alcohol, oils such as mineral, vegetable, animal and synthetic non-silicone oils, non-silicone waxes and silicones.

[000196] In some embodiments, the alcohols and esters have at least one linear or branched, saturated or unsaturated hydrocarbon group, comprising 6 to 30 carbon atoms, optionally
30 substituted, for example, with at least one hydroxyl group (for example 1 to 4). If they are unsaturated, these compounds can have one to three, conjugated or unconjugated, carbon-carbon double bonds.

[000197] With regard to the lower alkanes, in some embodiments, these have from 6 to 16 carbon atoms and are linear or branched, optionally cyclic. As examples, alkanes can be chosen from hexane and dodecane, isoparaffins such as
5 isohexadecane and isodecane.

[000198] Non-limiting examples of non-silicone oils usable in the composition of the disclosure, include: hydrocarbon oils of animal origin, such as perhydrosqualene; hydrocarbon oils of vegetable origin, such as liquid triglycerides of fatty
10 acids having from 6 to 30 carbon atoms such as triglycerides of heptanoic or octanoic acids, or for example sunflower oil, maize oil, soya oil, cucurbit oil, grapeseed oil, sesame oil, hazelnut oil, apricot oil, macadamia oil, arara oil, sunflower oil, castor oil, avocado oil, triglycerides of caprylic/capric
15 acids such as those sold by the company Stearineries Dubois or those sold under the names MIGLYOL® 810, 812 and 818 by the company Dynamit Nobel, jojoba oil, shea butter oil; hydrocarbons with more than 16 carbon atoms, linear or branched, of mineral or synthetic origin, such as paraffin
20 oils, petroleum jelly, liquid paraffin, polydecenes, hydrogenated polyisobutene such as Parleam®. fluorinated, partially hydrocarbon oils; as fluorinated oils, non-limiting examples include perfluoromethylcyclopentane and perfluoro-1,3-dimethylcyclohexane, sold under the names "FLUTECH® PC1"
25 and "FLUTECH® PC3" by the company BNFL Fluorochemicals; perfluoro-1,2-dimethylcyclobutane; perfluoroalkanes such as dodecafluoropentane and tetradecafluorohexane, sold under the names "PF 5050®" and "PF 5060®" by the 3M Company, or bromoperfluorooctyl sold under the name "FORALKYL®" by the
30 company Atochem; nonafluoro-methoxybutane and nonafluoroethoxyisobutane; derivatives of perfluoromorpholine, such as 4-trifluoromethyl perfluoromorpholine sold under the name "PF 5052®" by the 3M Company.

[000199] The fatty alcohols usable as fatty substances in the composition of the disclosure include, but are not limited to, non-alkoxylated, saturated or unsaturated, linear or branched, and have from 6 to 30 carbon atoms and more particularly from
5 8 to 30 carbon atoms; For example, cetyl alcohol, stearyl alcohol and their mixture (cetylstearyl alcohol), octyldodecanol, 2-butyloctanol, 2-hexyldecanol, 2-undecylpentadecanol, oleic alcohol or linoleic alcohol.

[000200] The exemplary non-silicone wax or waxes that can be
10 used in the composition of the disclosure are chosen from carnauba wax, candelilla wax, and Alfa wax, paraffin wax, ozokerite, vegetable waxes such as olive wax, rice wax, hydrogenated jojoba wax or absolute waxes of flowers such as the essential wax of blackcurrant flower sold by the company
15 BERTIN (France), animal waxes such as beeswaxes, or modified beeswaxes (cerabellina); other waxes or waxy raw materials usable according to the disclosure are, for example, marine waxes such as that sold by the company SOPHIM under reference M82, waxes of polyethylene or of polyolefins in general.

[000201] The exemplary fatty acid esters are the esters of
20 saturated or unsaturated, linear or branched C₁-C₂₆ aliphatic mono- or polyacids and of saturated or unsaturated, linear or branched C₁-C₂₆ aliphatic mono- or polyalcohols, the total number of carbons of the esters being, for example, greater
25 than or equal to 10.

[000202] Among the monoesters, non-limiting mentions can be made of dihydroabietyl behenate; octyldodecyl behenate; isocetyl behenate; cetyl lactate; C₁₂-C₁₅ alkyl lactate; isostearyl lactate; lauryl lactate; linoleyl lactate; oleyl
30 lactate; (iso)stearyl octanoate; isocetyl octanoate; octyl octanoate; cetyl octanoate; decyl oleate; isocetyl isostearate; isocetyl laurate; isocetyl stearate; isodecyl octanoate; isodecyl oleate; isononyl isononanoate; isostearyl

palmitate; methyl acetyl ricinoleate; myristyl stearate; octyl
isononanoate; 2-ethylhexyl isononate; octyl palmitate; octyl
pelargonate; octyl stearate; octyldodecyl erucate; oleyl
erucate; ethyl and isopropyl palmitates, ethyl-2-hexyl
5 palmitate, 2-octyldecyl palmitate, alkyl myristates such as
isopropyl, butyl, cetyl, 2-octyldodecyl, mirystyl, stearyl
myristate, hexyl stearate, butyl stearate, isobutyl stearate;
dioctyl malate, hexyl laurate, and 2-hexyldecyl laurate.

[000203] Further non-limiting mentions of esters can be made
10 of the esters of C₄-C₂₂ di- or tricarboxylic acids and of C₁-C₂₂
alcohols and the esters of mono-, di- or tricarboxylic acids
and of C₂-C₂₆ di-, tri-, tetra- or pentahydroxy alcohols.

[000204] Even further non-limiting examples of esters
include: diethyl sebacate; diisopropyl sebacate; diisopropyl
15 adipate; di-n-propyl adipate; dioctyl adipate; diisostearyl
adipate; dioctyl maleate; glyceryl undecylenate; octyldodecyl
stearoyl stearate; pentaerythrityl monoricinoleate;
pentaerythrityl tetraisononanoate; pentaerythrityl
tetrapelargonate; pentaerythrityl tetraisostearate;
20 pentaerythrityl tetraoctanoate; propylene glycol dicaprylate;
propylene glycol dicaprinate, tridecyl erucate; triisopropyl
citrate; triisostearyl citrate; glyceryl trilactate; glyceryl
trioctanoate; trioctyldodecyl citrate; trioleyl citrate,
propylene glycol dioctanoate; neopentyl glycol diheptanoate;
25 diethylene glycol diisononate; and polyethylene glycol
distearates.

[000205] Among the esters mentioned above, exemplary esters
include ethyl, isopropyl, myristyl, cetyl, stearyl palmitates,
ethyl-2-hexyl palmitate, 2-octyldecyl palmitate, alkyl
30 myristates such as isopropyl, butyl, cetyl, 2-octyldodecyl
myristate, hexyl stearate, butyl stearate, isobutyl stearate;
dioctyl malate, hexyl laurate, 2-hexyldecyl laurate and
isononyl isononanoate, cetyl octanoate.

[000206] The composition can also comprise, as fatty ester, esters and di-esters of sugars of C₆-C₃₀, such as C₁₂-C₂₂ fatty acids. "Sugar" as used in the disclosure means oxygen-containing hydrocarbon compounds that possess several alcohol
5 functions, with or without aldehyde or ketone functions, and having at least 4 carbon atoms. These sugars can be monosaccharides, oligosaccharides or polysaccharides.

[000207] As suitable sugars, non-limiting examples include sucrose, glucose, galactose, ribose, fucose, maltose, fructose,
10 mannose, arabinose, xylose, lactose, and their derivatives, for example alkylated, such as methylated derivatives such as methylglucose.

[000208] The esters of sugars and of fatty acids can, for example, be chosen from the esters or mixtures of esters of
15 sugars described previously and of linear or branched, saturated or unsaturated C₆-C₃₀, such as C₁₂-C₂₂ fatty acids. If they are unsaturated, these compounds can have one to three, conjugated or unconjugated, carbon-carbon double bonds.

[000209] The esters according to at least one embodiment can
20 also be chosen from mono-, di-, tri- and tetra-esters, polyesters and mixtures thereof.

[000210] These esters can be for example oleate, laurate, palmitate, myristate, behenate, cocoate, stearate, linoleate, linolenate, caprate, arachidonates, or mixtures thereof such
25 as the oleo-palmitate, oleo-stearate, palmito-stearate mixed esters.

[000211] For example, the mono- and di-esters can be used, and such as the mono- or di-oleate, stearate, behenate, oleopalmitate, linoleate, linolenate, oleostearate, of sucrose,
30 of glucose or of methylglucose.

[000212] Non-limiting mention can be made of the product sold under the name GLUCATE® DO by the company Amerchol, which is a dioleate of methylglucose.

[000213] Exemplary esters or of mixtures of esters of sugar of fatty acid include: the products sold under the names F160, F140, F110, F90, F70, SL40 by the company Crodesta, denoting respectively the palmito-stearates of sucrose formed from 73%
5 of monoester and 27% of di- and tri-ester, from 61% of monoester and 39% of di-, tri-, and tetra-ester, from 52% of monoester and 48% of di-, tri-, and tetra-ester, from 45% of monoester and 55% of di-, tri-, and tetra-ester, from 39% of monoester and 61% of di-, tri-, and tetra-ester, and the mono-
10 laurate of sucrose; the products sold under the name Ryoto Sugar Esters for example with the reference B370 and corresponding to the behenate of sucrose formed from 20% of monoester and 80% of di-triester-polyester; sucrose mono-di-palmito-stearate marketed by the company Goldschmidt under the
15 name TEGOSOFT® PSE.

[000214] The silicones usable in the composition of the present disclosure include but are not limited to volatile or non-volatile, cyclic, linear or branched silicones, modified or not with organic groups, having a viscosity from 5×10^{-6} to
20 $2.5 \text{ m}^2/\text{s}$ at 25°C , such as from 1×10^{-5} to $1 \text{ m}^2/\text{s}$.

[000215] The silicones usable according to the disclosure can be in the form of oils, waxes, resins or gums.

[000216] In some embodiments, the silicone is chosen from the polydialkylsiloxanes, such as the polydimethylsiloxanes (PDMS),
25 and the organo-modified polysiloxanes having at least one functional group selected from the poly(alkoxylated) groups, the amine groups and the alkoxy groups.

[000217] The organopolysiloxanes are defined in more detail in the work of Walter NOLL "Chemistry and Technology of
30 Silicones" (1968), Academic Press. They can be volatile or non-volatile.

[000218] When they are volatile, the silicones are, for example, chosen from those with a boiling point between 60° and 260°, and for further examples, chosen from:

[000219] the cyclic polydialkylsiloxanes having from 3 to 7, such as from 4 to 5 silicon atoms. It can be, for example, the octamethylcyclotetrasiloxane marketed under the name VOLATILE SILICONE® 7207 by UNION CARBIDE or SILBIONE® 70045 V2 by RHODIA, the decamethylcyclopentasiloxane marketed under the name VOLATILE SILICONE® 7158 by UNION CARBIDE, and SILBIONE® 70045 V5 by RHODIA, and mixtures thereof.

[000220] Non-limiting mentions can also be made of the cyclocopolymers of the dimethylsiloxanes/methylalkylsiloxane type, such as SILICONE VOLATILE® FZ 3109 marketed by the company UNION CARBIDE, of the formula XV:

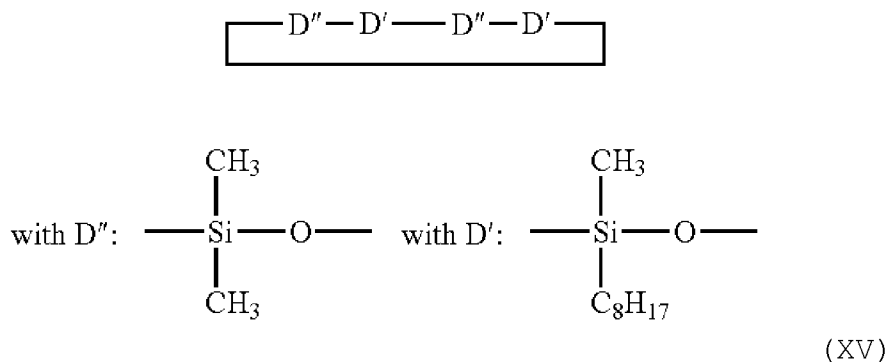

15

[000221] Non-limiting mentions can further be made of the mixtures of cyclic polydialkylsiloxanes with organic compounds derived from silicon, such as the mixture of octamethylcyclotetrasiloxane and tetratrimethylsilylpentaerythritol (50/50) and the mixture of octamethylcyclotetrasiloxane and oxy-1,1'-(hexa-2,2,2',2',3,3'-trimethylsilyloxy) bis-neopentane.

20

[000222] Other suitable volatile silicones include the linear volatile polydialkylsiloxanes having 2 to 9 silicon atoms and with a viscosity less than or equal to 5×10^{-6} m²/s at 25°C. An example is decamethyltetrasiloxane, marketed under the name "SH 200" by the company TORAY SILICONE. Silicones included in

25

this class are also described in the article published in Cosmetics and Toiletries, Vol. 91, Jan. 76, p. 27-32--TODD BYERS "Volatile Silicone fluids for cosmetics".

[000223] Even further non-limiting mentions can be made of
5 non-volatile polydialkylsiloxanes, gums and resins of polydialkylsiloxanes, polyorganosiloxanes modified with the aforementioned organofunctional groups, and mixtures thereof.

[000224] These silicones are, for example, chosen from the polydialkylsiloxanes, such as the polydimethylsiloxanes with
10 trimethylsilyl end groups. The viscosity of the silicones is measured at 25°C according to Standard Test Method for Kinematic Viscosity of Transparent and Opaque Liquids (and Calculation of Dynamic Viscosity)

[000225] Among these polydialkylsiloxanes, mention can be
15 made of, non-exhaustively, the following commercial products: the SILBIONE® oils of series 47 and 70 047 or the MIRASIL® oils marketed by RHODIA, for example the oil 70 047 V 500 000; the oils of the MIRASIL® series marketed by the company RHODIA; the oils of the 200 series from the company DOW
20 CORNING such as DC200, with a viscosity of 60 000 mm²/s; the VISCASIL® oils from GENERAL ELECTRIC and certain oils of the SF series (SF 96, SF 18) from GENERAL ELECTRIC.

[000226] Non-limiting mention can also be made of the polydimethylsiloxanes with dimethylsilanol end groups known
25 under the name of dimethiconol (CTFA), such as the oils of the 48 series from the company RHODIA.

[000227] In this class of polydialkylsiloxanes, non-limiting mentions can be made of the products marketed under the names "ABIL WAX® 9800 and 9801" by the company GOLDSCHMIDT, which
30 are polydialkyl (C₁-C₂₀) siloxanes.

[000228] The silicone gums usable according to the disclosure are, for example, polydialkylsiloxanes, such as polydimethylsiloxanes with high number-average molecular

weights between 200,000 and 1,000,000 used alone or mixed in a solvent. This solvent can be chosen from the volatile silicones, the polydimethylsiloxane (PDMS) oils, the polyphenylmethylsiloxane (PPMS) oils, the isoparaffins, the
5 polyisobutylenes, methylene chloride, pentane, dodecane, tridecane and mixtures thereof.

[000229] Products usable according to the disclosure are, for example, mixtures such as: mixtures formed from a chain end hydroxylated polydimethylsiloxane, or dimethiconol (CTFA) and
10 a cyclic polydimethylsiloxane also called cyclomethicone (CTFA), such as the product Q2 1401 marketed by the company DOW CORNING; mixtures of a polydimethylsiloxane gum and a cyclic silicone such as the product SF 1214 Silicone Fluid from the company GENERAL ELECTRIC, said product being a gum SF
15 30 corresponding to a dimethicone, having a number-average molecular weight of 500,000, dissolved in the oil SF 1202 Silicone Fluid corresponding to decamethylcyclopentasiloxane; mixtures of two PDMS of different viscosities, for example, of a PDMS gum and a PDMS oil, such as the product SF 1236 from
20 the company GENERAL ELECTRIC. The product SF 1236 is a mixture of a gum SE 30 as defined above having a viscosity of 20 m²/s and an oil SF 96 with a viscosity of 5 x 10⁻⁶ m²/s. This product, for example, has 15% of gum SE 30 and 85% of oil SF 96.

25 [000230] The organopolysiloxane resins usable according to the disclosure include but are not limited to crosslinked siloxane systems containing the units: R₂SiO_{2/2}, R₃SiO_{1/2}, RSiO_{3/2} and SiO_{4/2}

[000231] in which R represents an alkyl having 1 to 16 carbon
30 atoms. For example, R denotes a C₁-C₄ lower alkyl group such as methyl.

[000232] Among these resins, non-limiting mention can be made of the product marketed under the name "DOW CORNING® 593" or

those marketed under the names "SILICONE FLUID SS 4230 and SS 4267" by the company GENERAL ELECTRIC, which are silicones of dimethyl/trimethyl siloxane structure.

[000233] Non-limiting mention can also be made of the resins
5 of the trimethylsiloxysilicate type, such as those marketed under the names X22-4914, X21-5034 and X21-5037 by the company SHIN-ETSU.

[000234] The organomodified silicones usable according to the disclosure include but are not limited to silicones as defined
10 previously, having in their structure at least one organofunctional group fixed by a hydrocarbon group.

[000235] In addition to the silicones described above, the organomodified silicones can be polydiaryl siloxanes, such as polydiphenylsiloxanes, and polyalkyl-arylsiloxanes
15 functionalized by the aforementioned organofunctional groups.

[000236] The polyalkarylsiloxanes are, for example, chosen from the polydimethyl/methylphenylsiloxanes, the polydimethyl/diphenylsiloxanes, linear and/or branched, with viscosity ranging from 1×10^{-5} to 5×10^2 m²/s at 25°C.

[000237] Among these polyalkarylsiloxanes, non-limiting
20 mentins can be made of the products marketed under the following names: the SILBIONE® oils of series 70 641 from RHODIA; the oils of the series RHODORSIL® 70 633 and 763 from RHODIA; the oil DOW CORNING® 556 COSMETIC GRADE FLUID from DOW
25 CORNING; the silicones of the PK series from BAYER such as the product PK20; the silicones of the series PN, PH from BAYER such as the products PN1000 and PH1000; certain oils of the SF series from GENERAL ELECTRIC such as SF 1023, SF 1154, SF 1250, SF 1265.

[000238] Among the organomodified silicones, non-limiting
30 mention can be made of the polyorganosiloxanes having: polyoxyethylene and/or polyoxypropylene groups optionally with C₆-C₂₄ alkyl groups such as the products called dimethicone

copolyol marketed by the company DOW CORNING under the name DC 1248 or the oils SILWET® L 722, L 7500, L 77, L 711 from the company UNION CARBIDE and the alkyl (C₁₂)-methicone copolyol marketed by the company DOW CORNING under the name Q2 5200;
5 substituted or unsubstituted amine groups such as the products marketed under the name GP 4 Silicone Fluid and GP 7100 by the company GENESEE or the products marketed under the names Q2 8220 and DOW CORNING® 929 or 939 by the company DOW CORNING. The substituted amine groups are, for example, C₁-C₄ aminoalkyl
10 groups; alkoxyated groups, such as the product marketed under the name "SILICONE COPOLYMER F-755" by SWS SILICONES and ABIL WAX® 2428, 2434 and 2440 by the company GOLDSCHMIDT.

[000239] In some embodiments, the at least one fatty substance is neither alkoxyated, nor glycerolated.

15 [000240] For example, the at least one fatty substance is chosen from compounds that are liquid or pasty at room temperature and at atmospheric pressure.

[000241] For further example, the at least one fatty substance is a compound that is liquid at a temperature of
20 25°C and at atmospheric pressure.

[000242] The at least one fatty substance is, for example, chosen from the lower alkanes, fatty alcohols, esters of fatty acid, esters of fatty alcohol, and oils such as non-silicone mineral, vegetable and synthetic oils, the silicones.

25 [000243] According to at least one embodiment, the at least one fatty substance is chosen from liquid paraffin, polydecenes, liquid esters of fatty acids and of fatty alcohols, and mixtures thereof, for example, the at least one fatty substance of the composition according to the disclosure
30 can be non-silicone.

[000244] In some embodiments, the at least one fatty substance is chosen from alkanes, hydrocarbons and silicones.

[000245] The composition according to the disclosure comprises at least one fatty substance other than a fatty acid, which is present in the composition in an amount of at least 10% by weight relative to the total weight of the composition.

5 For example, the concentration of fatty substances is from about 10% to about 80% by weight, such as from about 15% to about 65% by weight, further such as from about 20% to about 55% by weight, based on the total weight of the composition.

10 SALTS

[000246] The composition of the present invention may further comprise at least one salt.

[000247] The at least one salt of the present invention may be chosen from alkali earth metal salts and metal salts.

15 [000248] Suitable alkali earth metal salts may be chosen from Lithium, Sodium, Potassium, Magnesium, Calcium, Barium salts.

[000249] Suitable metal salts may be chosen from Manganese, Iron, Copper, Silver, Zinc, Aluminum salts.

[000250] In some embodiments, the salt is a mono- or a
20 divalent metal. In some embodiments, the metal salt is a salt of a transition metal. In other embodiments, the metal salt is not a salt of an alkali earth metal.

[000251] The at least one salt of the present invention may be also chosen from salt compounds having organic counterions
25 and salt compounds having polyatomic counterions such as an ammonium ion or such as a substituted ammonium ion.

[000252] In other embodiments, the at least one salt of the present invention may be chosen from silicates. Suitable silicates include, but are not limited to, metal silicates,
30 organic silicates and polyatomic silicates.

[000253] Within the meaning of the present disclosure, "salt" is understood to include, but not limited to, the oxides and hydroxides of metals and the salts proper that can result from

the action of an acid on a metal. In some embodiments, the at least one salt is not an oxide. In some embodiments, the at least one salt is not a hydroxide. Mention may be made, among the salts, of halides, such as chlorides, fluorides and iodides, sulfates, phosphates, lactates, acetates, glycinates, aspartates, nitrates, perchlorates, carbonates, hydrogen carbonates, silicates, borates and salts of carboxylic acids and polymeric complexes which can support said salts, and also their mixtures.

5 [000254] The salts of carboxylic acids which can be used in the disclosure also include salts of hydroxylated carboxylic acids, such as gluconate.

[000255] Mention may be made, as example of polymeric complexes which can support said salts, of manganese pyrrolidonecarboxylate.

15 [000256] One particularly preferred salt of the present invention is sodium sulfate.

[000257] It was surprisingly found that when the at least one salt is employed in the compositions of the present invention, less amounts of the alkaline agent and/or the oxidizing agent are necessary in order to achieve the desired degree of coloring of keratinous substrates. This would be more desirable since higher levels of the alkaline agent and/or oxidizing agent could result in more damage to the hair.

20 [000258] Moreover, when both the at least one salt and an oxidizing agent are present in the compositions of the present invention, peroxy compounds such as peroxyacids and peroxy salts, for example, peroxyborates, peroxy carbonates and peroxy sulfates, may form in said compositions.

25 [000259] The at least one salt of the present invention can be present in an amount ranging from about 0.001% to about 40% by weight or from about 0.05% to about 30% by weight, or from

about 0.1% to about 20%, or from about 1% to about 15%, based on the total weight of the composition.

CATIONIC POLYMERS

5 [000260] The composition of the present invention may further comprise at least one cationic polymer.

[000261] In at least one embodiment, the at least one cationic polymer included in the composition of the disclosure is not chosen from cationic associative polymers. In other
10 words, these cationic polymers do not comprise in their structure a pendent or terminal hydrophobic chain, for example of alkyl or alkenyl type, containing from 10 to 30 carbon atoms.

[000262] The at least one cationic polymer of the composition
15 according to the disclosure can be chosen from, for example:

[000263] (1) homopolymers and copolymers derived from acrylic or methacrylic esters or amides and comprising at least one unit chosen from units of formulae (XVI), (XVII), (XVIII) and (XIX):

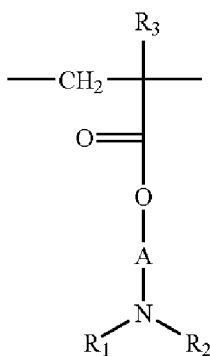

(XVI)

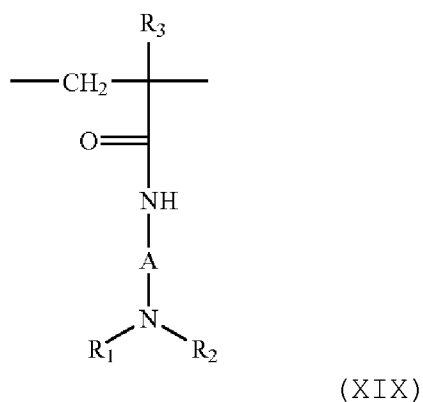
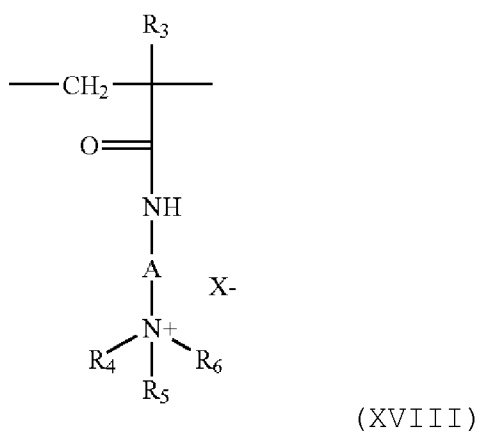
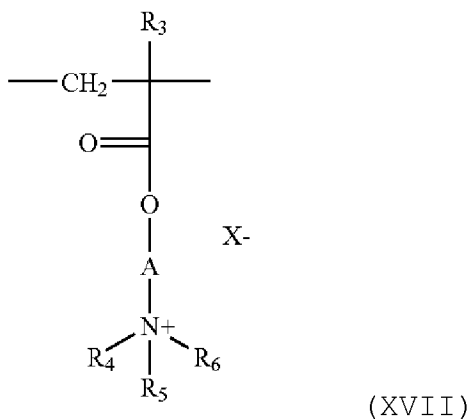

wherein:

5 [000264] R₃, which may be identical or different, denotes a hydrogen atom or a CH₃ radical;

[000265] A, which may be identical or different, represents a linear or branched C₁-C₆ and, for example, C₂-C₃ alkyl group or a C₁-C₄ hydroxyalkyl group;

[000266] R_4 , R_5 and R_6 , which may be identical or different, represent a C_1 - C_{18} alkyl group or a benzyl radical, such as a C_1 - C_6 alkyl group;

[000267] R_1 and R_2 , which may be identical or different,
5 represent hydrogen or a C_1 - C_6 alkyl group, for example methyl or ethyl;

[000268] X^- denotes an anion derived from a mineral or organic acid, such as a methosulfate anion or a halide such as chloride or bromide.

10 [000269] The polymers of this family can also contain at least one unit derived from at least one comonomer which may be chosen from the family of acrylamides, methacrylamides, diacetone acrylamides, acrylamides and methacrylamides substituted on the nitrogen with lower (C_1 - C_4) alkyls, acrylic
15 or methacrylic acids or esters thereof, vinyl lactams such as vinylpyrrolidone or vinylcaprolactam, and vinyl esters.

[000270] Thus, among the polymers of this family, exemplary mention may be made of:

[000271] copolymers of acrylamide and of dimethylaminoethyl
20 methacrylate quaternized with dimethyl sulfate or with a dimethyl halide, such as the product sold under the name HERCOFLOC by the company Hercules,

[000272] the copolymers of acrylamide and of
25 methacryloyloxyethyltrimethylammonium chloride described, for example, in EP 80 976 and sold under the name BINA QUAT P 100 by the company Ciba Geigy,

[000273] the copolymer of acrylamide and of
methacryloyloxyethyltrimethylammonium methosulfate sold under the name RETEN by the company Hercules,

30 [000274] quaternized or non-quaternized vinylpyrrolidone/dialkylaminoalkyl acrylate or methacrylate copolymers, such as the products sold under the name GAFQUAT by the company ISP,

for instance GAFQUAT 734 or GAFQUAT 755, or alternatively the products known as COPOLYMER 845, 958 and 937,

[000275] dimethylaminoethyl methacrylate/ vinylcaprolactam/ vinylpyrrolidone terpolymers, such as the product sold under
5 the name GAFFIX VC 713 by the company ISP,

[000276] vinylpyrrolidone/methacrylamidopropyl dimethylamine copolymers sold, for example, under the name STYLEZE CC 10 by ISP,

[000277] quaternized vinylpyrrolidone/

10 dimethylaminopropylmethacrylamide copolymers such as the product sold under the name GAFQUAT HS 100 by the company ISP, and crosslinked polymers of methacryloyloxy(C₁-C₄)alkyltri(C₁-C₄)alkylammonium salts such as the polymers obtained by homopolymerization of dimethylaminoethyl methacrylate

15 quaternized with methyl chloride, or by copolymerization of acrylamide with dimethylaminoethyl methacrylate quaternized with methyl chloride, the homo- or copolymerization being followed by crosslinking with a compound containing olefinic unsaturation, such as methylenebisacrylamide. In at least one

20 embodiment, a crosslinked acrylamide/ methacryloyloxyethyltrimethylammonium chloride copolymer (20/80 by weight) in the form of a dispersion containing 50% by weight of the copolymer in mineral oil can be used. This

dispersion is sold under the name SALCARE® SC 92 by the
25 company Ciba. In some embodiments, a crosslinked methacryloyloxyethyltrimethylammonium chloride homopolymer containing about 50% by weight of the homopolymer in mineral oil or in a liquid ester can be used. These dispersions are

sold under the names SALCARE® SC 95 and SALCARE® SC 96 by the
30 company Ciba.

[000278] Other examples are cellulose ether derivatives comprising quaternary ammonium groups, such as the polymers

sold under the names JR (JR 400, JR 125, JR 30M) or LR (LR 400, LR 30M) by the company Union Carbide Corporation.

[000279] (2) copolymers of cellulose or cellulose derivatives grafted with a water-soluble quaternary ammonium monomer, such as hydroxymethyl-, hydroxyethyl- or hydroxy-propylcelluloses grafted, for instance, with a methacryloylethyltrimethylammonium, methacrylamidopropyltrimethylammonium or dimethyldiallylammonium salt. These are sold under the name CELQUAT L 200 and CELQUAT H 100 by the company National Starch.

[000280] (3) non-cellulose cationic polysaccharides, such as guar gums containing trialkylammonium cationic groups. Such products are sold, for example, under the trade names JAGUAR C13S, JAGUAR C15, JAGUAR C17 and JAGUAR C162 by the company Meyhall.

[000281] (4) polymers of piperazinyl units and of divalent alkylene or hydroxyalkylene radicals.

[000282] (5) water-soluble polyamino amides prepared, for example, by polycondensation of an acidic compound with a polyamine; these polyamino amides can be crosslinked with an epihalohydrin, a diepoxide, a dianhydride, an unsaturated dianhydride, a bis-unsaturated derivative, a bis-halohydrin, a bis-azetidinium, a bis-haloacyldiamine, a bis-alkyl halide or alternatively with an oligomer resulting from the reaction of a difunctional compound which is reactive with a bis-halohydrin, a bis-azetidinium, a bis-haloacyldiamine, a bis-alkyl halide, an epihalohydrin, a diepoxide or a bis-unsaturated derivative; the crosslinking agent being used in an amount ranging from 0.025 to 0.35 mol per amine group of the polyamino amide; these polyamino amides can be alkylated or, if they contain at least one tertiary amine function, they can be quaternized. Exemplary mention may be made of the adipic acid/dimethylaminohydroxypropyl/diethylenetriamine

polymers sold under the name CARTARETINE F, F4 or F8 by the company Sandoz.

[000283] (6) the polymers obtained by reaction of at least one polyalkylene polyamine containing two primary amine groups and at least one secondary amine group with a dicarboxylic acid chosen from diglycolic acid and saturated C₃-C₈ aliphatic dicarboxylic acids. The molar ratio between the polyalkylene polyamine and the dicarboxylic acid ranges from 0.8:1 to 1.4:1; the polyamino amide resulting therefrom is reacted with epichlorohydrin in a molar ratio of epichlorohydrin relative to the secondary amine group of the polyamino amide ranging from 0.5:1 to 1.8:1. Polymers of this type are sold, for example, under the name HERCOSETT 57, PD 170 or DELSETTE 101 by the company Hercules.

[000284] (7) cyclopolymers of alkyldiallylamine and of dialkyldiallylammonium, such as the homopolymers or copolymers containing, as main constituent of the chain, at least one unit corresponding to formula (XX) or (XXI):

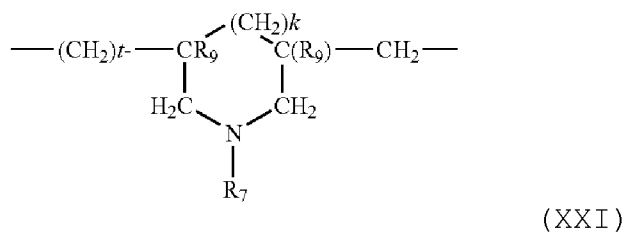
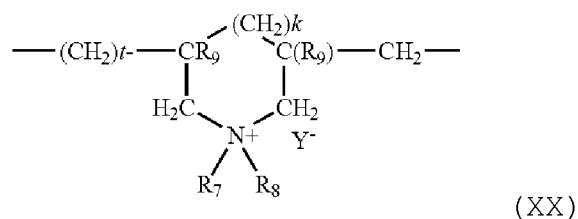

[000285] wherein formulae k and t are equal to 0 or 1, the sum k+t being equal to 1; R₉ denotes a hydrogen atom or a methyl radical; R₇ and R₈, independently of each other, denote a C₁-C₈ alkyl group, a hydroxyalkyl group in which the alkyl group is C₁-C₅, an amidoalkyl group in which the alkyl is C₁-C₄;

or R₇ and R₈ denote, together with the nitrogen atom to which they are attached, a heterocyclic group such as piperidyl or morpholinyl; in at least one embodiment R₇ and R₈, independently of each other, denote a C₁-C₄ alkyl group; Y⁻ is
 5 an organic or mineral anion such as bromide, chloride, acetate, borate, citrate, tartrate, bisulfate, bisulfite, sulfate or phosphate.

[000286] Among the polymers defined above, exemplary mention may be made of the dimethyldiallylammonium chloride
 10 homopolymer sold under the name MERQUAT 100 and MERQUAT 280 by the company Nalco (and its homologues of low weight-average molecular mass) and the copolymers of diallyldimethylammonium chloride and of acrylamide, sold under the name MERQUAT 550.

[000287] (8) quaternary diammonium polymers containing
 15 repeating units of formula (XXII):

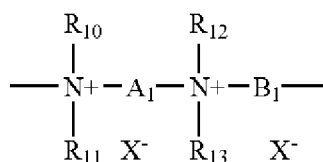

(XXII)

herein:

[000288] R₁₀, R₁₁, R₁₂ and R₁₃, which may be identical or different, represent C₁-C₆ aliphatic, alicyclic or
 20 arylaliphatic radicals or hydroxyalkylaliphatic radicals wherein the alkyl radical is C₁-C₄, or alternatively R₁₀, R₁₁, R₁₂ and R₁₃, together or separately, constitute, with the nitrogen atoms to which they are attached, heterocycles optionally containing a second heteroatom other than nitrogen,
 25 or alternatively R₁₀, R₁₁, R₁₂ and R₁₃ represent a linear or branched C₁-C₆ alkyl radical substituted with a nitrile, ester, acyl or amide group or a group --CO--O--R₁₄-D or --CO--NH--R₁₄-D wherein R₁₄ is an alkylene and D is a quaternary ammonium group;

[000289] A₁ and B₁ represent C₂-C₆ polymethylene groups which are linear or branched, saturated or unsaturated, and which optionally contain, linked to or intercalated in the main chain, at least one aromatic ring or at least one atom chosen
5 from oxygen and sulfur atom or at least one group chosen from sulfoxide, sulfone, disulfide, amino, alkylamino, hydroxyl, quaternary ammonium, ureido, amide and ester groups, and

[000290] X⁻ denotes an anion derived from a mineral or organic acid;

10 [000291] A₁, R₁₀ and R₁₂ can form, with the two nitrogen atoms to which they are attached, a piperazine ring;

[000292] and wherein, if A₁ denotes a linear or branched, saturated or unsaturated alkylene or hydroxyalkylene radical, B₁ can also denote a group --(CH₂)_n--CO-D-OC--(CH₂)_n-- wherein n

15 is a number ranging from 1 to 6, and D is chosen from:

a) a glycol residue of formula: --O--Z--O--, where Z denotes a linear or branched hydrocarbon-based radical or a group corresponding to one of the following formulae: --(CH₂-CH₂--O)_x--CH₂--CH₂--; or --
20 [CH₂--CH(CH₃)--O]_y--CH₂ --CH(CH₃)--, where x and y denote an integer ranging from 1 to 4, representing a defined and unique degree of polymerization or any number ranging from 1 to 4 representing an average degree of polymerization;

25 b) a bis-secondary diamine residue such as a piperazine derivative;

c) a bis-primary diamine residue of formula: --NH--Y--NH--, wherein Y denotes a linear or branched hydrocarbon-based radical, or alternatively the
30 radical --CH₂--CH₂--S--S--CH₂--CH₂--; and

d) an ureylene group of formula: --NH--CO--NH--.

[000293] In at least one embodiment, X⁻ is an anion such as chloride or bromide.

[000294] These polymers, for example, have a number-average molecular mass ranging from 1000 to 100,000.

[000295] In some embodiments, polymers are used that consist of repeating units corresponding to formula (XXIII):

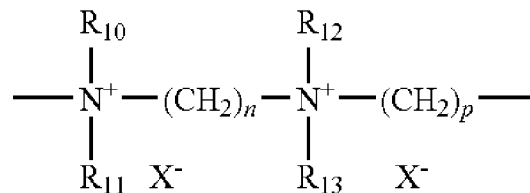

5

(XXIII)

[000296] wherein R₁₀, R₁₁, R₁₂ and R₁₃, which may be identical or different, denote a C₁-C₄ alkyl or hydroxyalkyl radical, n and p are integers ranging from 2 to 6, and X⁻ is an anion derived from a mineral or organic acid.

10

[000297] In at least one embodiment, the at least one cationic polymer corresponding to this family comprise repeating units of formulae (W) and (U):

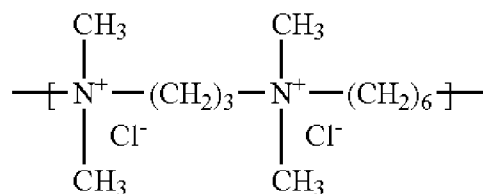

(W)

[000298] for example those whose molecular weight, determined by gel permeation chromatography, ranges from 9,500 to 9,900;

15

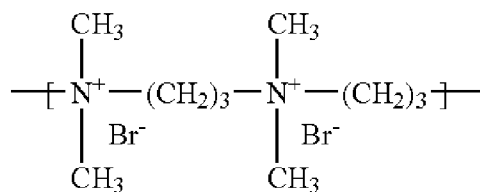

(U)

[000299] for instance those whose molecular weight, determined by gel permeation chromatography, is 1200.

[000300] (9) polyquaternary ammonium polymers consisting of repeating units of formula (XXIV):

20

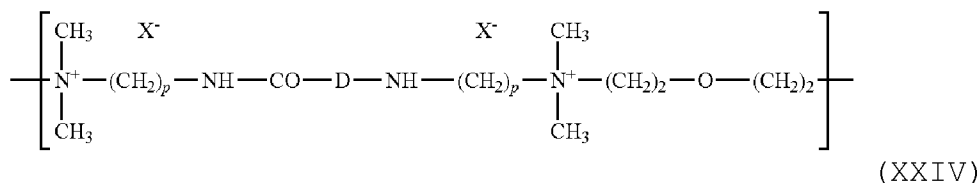

[000301] wherein p denotes an integer ranging from 1 to 6, D may be zero or may represent a group $-(\text{CH}_2)_r-\text{CO}-$ wherein r denotes a number ranging from 1 to 6, and X^- is an anion.

5 [000302] Such polymers may be prepared according to the processes described in U.S. Pat. Nos. 4,157,388, 4,702,906 and 4,719,282. They are described, for example, in patent application EP 122 324.

[000303] Among these polymers, examples that may be mentioned
10 include the products MIRAPOL A 15, MIRAPOL AD1, MIRAPOL AZ1 and MIRAPOL 175 sold by the company Miranol.

[000304] (10) quaternary polymers of vinylpyrrolidone and of vinylimidazole, for instance the products sold under the names LUVIQUAT FC 905, FC 550 and FC 370 by the company BASF.

15 [000305] (11) vinylamide homopolymers or copolymers, such as partially hydrolysed vinylamide homopolymers such as poly(vinylamine/vinylamide)s.

[000306] (12) cationic polyurethane derivatives, for example those of elastic nature formed from the reaction:

20 [000307] (a1) of at least one cationic unit resulting from at least one tertiary or quaternary amine bearing at least two reactive functions containing labile hydrogen,

[000308] (a2) of at least one mixture of at least two different nonionic units bearing at least two reactive
25 functions containing labile hydrogen, for instance chosen from hydroxyl groups, primary or secondary amine groups, and thiol groups, and

[000309] (b) of at least one compound comprising at least two isocyanate functions.

[000310] (13) Other cationic polymers that may be used in the context of the disclosure include, for example, cationic proteins or cationic protein hydrolysates, polyalkyleneimines, such as polyethyleneimines, polymers containing vinylpyridine or vinylpyridinium units, and chitin derivatives.

[000311] Particularly useful cationic polymers in the present invention include, but are not limited to, polyquaternium 4, polyquaternium 6, polyquaternium 7, polyquaternium 10, polyquaternium 11, polyquaternium 16, polyquaternium 22, polyquaternium 28, polyquaternium 32, polyquaternium-46, polyquaternium-51, polyquaternium-52, polyquaternium-53, polyquaternium-54, polyquaternium-55, polyquaternium-56, polyquaternium-57, polyquaternium-58, polyquaternium-59, polyquaternium-60, polyquaternium-63, polyquaternium-64, polyquaternium-65, polyquaternium-66, polyquaternium-67, polyquaternium-70, polyquaternium-73, polyquaternium-74, polyquaternium-75, polyquaternium-76, polyquaternium-77, polyquaternium-78, polyquaternium-79, polyquaternium-80, polyquaternium-81, polyquaternium-82, polyquaternium-84, polyquaternium-85, polyquaternium-86, polyquaternium-87, polyquaternium-90, polyquaternium-91, polyquaternium-92, polyquaternium-94, and guar hydroxypropyltrimonium chloride.

[000312] Particularly preferred cationic polymers of the present invention include POLYMER JR-125, POLYMER JR-400, Polymer JR-30M hydroxyethyl cellulosic polymers (polyquaternium 10) available from AMERCHOL; JAGUAR C® 13-S, guar hydroxypropyltrimonium chloride, available from Rhodia; and MERQUAT® 100 and 280, a dimethyl dialkyl ammonium chloride (polyquaternium 6) available from Nalco.

[000313] The cationic polymer is generally present in an amount of from greater than 0% to about 15%, preferably from about 0.5% to about 10% by weight, and more preferably from about 1% to about 5% by weight, based on the total weight of

the composition.

OXIDIZING AGENT

[000314] The compositions of the present disclosure may
5 require an oxidizing agent when the colorant comprises an
oxidative dye. Oxidizing agents are used in an amount
sufficient for the oxidative dye to develop a color. The
oxidizing agents may be, for example, peroxide, a persulfate,
a perborate, a percarbonate, alkali metal bromates,
10 ferricyanides or a mixture thereof. Oxidizing agents that may
also be used include at least one redox enzyme such as
laccases, peroxidases, and 2-electron oxidoreductases, such as
uricase, where appropriate in the presence of their respective
donor or co-factor.

15 [000315] In one embodiment, the oxidizing agent is hydrogen
peroxide present in an aqueous solution whose titre may range
from 1 to 40 volumes, such as from 5 to 40 volumes.

[000316] In another embodiment, the oxidizing agent is a
persulfate and/or a monopersulfate such as, for example,
20 potassium persulfate, sodium persulfate, ammonium persulfate,
as well as mixtures thereof. In one embodiment the oxidizing
agents in the present disclosure are selected from hydrogen
peroxide, potassium persulfate, sodium persulfate and mixtures
thereof.

25 [000317] Typically, the oxidizing agent is provided in the
form of a developer composition.

[000318] In one embodiment, the oxidizing agent is present in
an amount of at least 1% by weight, based on the total weight
of the developer composition.

30 [000319] In another embodiment, the oxidizing agent is
present in an amount ranging from greater than 0 % by weight
to about 40 % by weight, or from about 0.01 % by weight to
about 30 % by weight, or from about 0.1 % by weight to about

20 % by weight, or from about 1% to about 15% by weight, based on the total weight of the developer composition.

DEVELOPER COMPOSITION

5 [000320] The developer composition may be in the form of a powder, gel, liquid, foam, lotion, cream, mousse, and emulsion.

[000321] In one particular embodiment, the developer composition is aqueous or is in the form of an emulsion.

10 [000322] In another embodiment, the developer composition is substantially anhydrous. The term "substantially anhydrous" means that the developer composition is either completely free of water or contains no appreciable amount of water, for example, no more than 5% by weight, or no more than 2% by
15 weight, or no more than 1% by weight, based on the weight of the developer composition. It should be noted that this refers for example to bound water, such as the water of crystallization of the salts or traces of water absorbed by the raw materials used in the preparation of the compositions
20 according to the disclosure.

[000323] The developer composition can contain at least one solvent, chosen from water, organic solvents, and mixtures thereof.

25 [000324] When the developer composition is substantially anhydrous, the developer composition may comprise at least one solvent chosen from organic solvents.

[000325] Suitable organic solvents for use in the developer composition include ethanol, isopropyl alcohol, benzyl alcohol, phenyl ethyl alcohol, glycols and glycol ethers, such
30 as propylene glycol, hexylene glycol, ethylene glycol monomethyl, monoethyl or monobutyl ether, propylene glycol and its ethers, such as propylene glycol monomethyl ether, butylene glycol, dipropylene glycol, diethylene glycol alkyl

ethers, such as diethylene glycol monoethyl ether and monobutyl ether, hydrocarbons such as straight chain hydrocarbons, mineral oil, polybutene, hydrogenated polyisobutene, hydrogenated polydecene, polydecene, squalane, petrolatum, isoparaffins, and mixtures, thereof.

5 [000326] The at least one solvent may, for example, be present in an amount ranging from about 0.5% to about 70% by weight, such as from about 2% to about 60% by weight, preferably from about 5% to about 50% by weight, relative to the total weight of the developer composition.

10 [000327] The pH of the developer composition can range from 2 to 12, such as from 6 to 11, and it may be adjusted to the desired value using acidifying/alkalizing agents that are well known in the art.

15

COSMETICALLY ACCEPTABLE MEDIUM

[000328] The dyeing composition according to the disclosure can be in various forms, such as in the form of liquids, creams, gels, lotions or paste.

20 [000329] The dyeing composition can comprise other compounds constituting the cosmetically acceptable medium. This cosmetically acceptable medium comprises water or a mixture of water and at least one cosmetically acceptable organic solvent.

[000330] As examples of organic solvents, non-limiting
25 mentions can be made of alcohols such as ethyl alcohol, isopropyl alcohol, benzyl alcohol, and phenylethyl alcohol, or glycols or glycol ethers such as, for example, monomethyl, monoethyl and monobutyl ethers of ethylene glycol, propylene glycol or ethers thereof such as, for example, monomethyl
30 ether of propylene glycol, butylene glycol, hexylene glycol, dipropylene glycol as well as alkyl ethers of diethylene glycol, for example monoethyl ether or monobutyl ether of diethylene glycol.

ADDITIVE

[000331] The dyeing composition according to the disclosure can also comprise at least one additive used conventionally in compositions for application onto hair.

[000332] "Additive" means a substance that is added, different from the compounds already mentioned.

[000333] As examples of additives that can be used, non-limiting mentions can be made of surfactants, antioxidants or reducing agents, penetrating agents, sequestering agents, perfumes, buffers, dispersants, conditioners, such as for example volatile or non-volatile, modified or unmodified silicones, film-forming agents, ceramides, preservatives, opacifiers, and antistatic agents.

[000334] In one embodiment, the composition of the present invention is a ready-to-use aqueous composition for the oxidative dyeing of keratinous substrates comprising, in a cosmetically acceptable medium,

a) from about 0.1 to about 5% by weight at least one amine selected from the group comprising fatty monoamine compounds, polyamine compounds having at least three amino groups and fatty quaternary amine compounds, or at least one phospholipid;

b) from about 1 to about 30% by weight at least one nonionic surfactant;

c) from about 0.5 to about 20% by weight at least one anionic silicone;

d) at least one oxidative dye chosen from oxidation bases and couplers;

e) optionally, at least one thickening agent;

f) from about 0.1 to about 15% by weight of at least one alkaline agent;

- g) at least 10% by weight of at least one fatty substance other than a fatty acid;
- h) optionally, at least one salt; and
- i) from about 0.1 to about 20% by weight of at least one oxidizing agent.

5

[000335] Preparation and Application of the dyeing composition

[000336] According one embodiment of the invention, the dyeing compositions according to the disclosure can be prepared from a dye composition comprising at least one direct dye as defined previously, with or without any developer composition.

[000337] According to another embodiment of the invention the dyeing compositions according to the disclosure can result from mixing two units, including a first unit of an oxidative dye containing composition as defined previously and a second unit of a developer composition as defined above, or vice versa.

[000338] According to yet another embodiment of the invention, a pre-treatment composition containing at least one salt may be provided and applied onto the keratinous substrates prior to the application of the dyeing composition.

[000339] It has been surprisingly discovered that the composition of the present invention enables acceptable levels of dye to be deposited onto keratinous substrates utilizing lower amounts of dye compared to conventional dyeing compositions.

[000340] Yet another surprising discovery is that in the event conventional amounts of dye are employed, the dyeing process may be completed in less time such as 20 minutes or 15 minutes or 10 minutes, thereby causing less damage to the keratinous substrates.

30

[000341] In the event that conventional levels of dye are employed, coupled with conventional dyeing times, significantly larger color deposit onto the keratinous substrate may be achieved.

5 [000342] Finally, the inventive composition contains large amounts of water, e.g., higher than 60%, or 80% by weight, which advantageously lowers the cost of production.

[000343] According to another embodiment of the invention, a kit for dyeing keratinous substrates is provided, comprising:

10 a first unit containing in a cosmetically acceptable medium: at least one amine selected from the group comprising fatty monoamine compounds, polyamine compounds having at least three amino groups and fatty quaternary amine compounds or at least one phospholipid ; at least one nonionic surfactant; at least
15 one anionic silicone; and at least one dye chosen from oxidation dye precursors and direct dyes; optionally, at least one thickening agent; optionally, at least one alkaline agent; optionally, at least one fatty substance other than a fatty acid; and optionally, at least one salt; and

20 [000344] a second unit comprising at least one oxidizing agent and optionally, at least one fatty substance other than a fatty acid.

[000345] According to yet another embodiment of the invention, the kit further comprises a third unit containing
25 at least one salt in a cosmetically acceptable medium.

[000346] The present invention will be better understood by the examples which follow, all of which are intended for illustrative purposes only, and are not meant to unduly limit the scope of the invention in any way.

30

EXAMPLES

[000347] The following example is intended for illustrative purposes only, and is not meant to unduly limit the scope of the invention in any way.

5

Example 1

(Low pH Blue Binary Color Deposit Study)

[000348] A test swatch of IHIP 90% gray hair (1cm width, 15cm length) was dyed with 20g of the mixture of the below dye composition mixed 1:1 with L'Oreal Majicreme™ 20 volume developer. The pH of the final mixture was adjusted to 6.5 using NaOH.

10

Ingredients	Example 1
DI Water	Q.S.
Oleamidopropyl Dimethylamine	2.0%
PPG-5 Ceteth-20	11.0%
Dimethicone PEG-7 Phosphate	8.0%
Mineral Oil	1.0%
N,N-Bis (2-hydroxyethyl) p-phenylenediamine Sulfate	1.47%
2,4-Diaminophenoxyethanol HCl	1.205%

15 [000349] A control swatch was dyed with the mixture of Redken Shades EQ™ clear, containing the same dyes at same levels as above, mixed 1:1 with Redken Shades EQ™ Processing solution. The pH of the final mixture was adjusted to 9.5 using NaOH.

[000350] Both swatches were processed for 20 minutes at RT, rinsed for 1 minute (80gph, 32°C), and dried. L*a*b* values were measured before and after coloring using Konica Minolta Spectrophotometer.

20

[000351] The final ΔL value measurements for the control and test swatches were -54.32 and -65.06, respectively. More

negative ΔL value indicates darker color. The color intensity difference is also visually significant. Therefore the inventive formula deposits greater amounts of color on the hair than the control in the 20 minutes processes.

5

Example 2

(High pH Blue Binary Color Deposit Study)

[000352] A test swatch of IHIP 90% gray hair (1cm width, 15cm length) was dyed with 20g of the mixture of the below dye composition mixed 1:1 with L'Oreal Majicreme™ 20 volume developer. The pH of the final mixture was adjusted to 9.5 using NaOH.

Ingredients	Example 2
DI Water	Q.S.
Oleamidopropyl Dimethylamine	2.0%
PPG-5 Ceteth-20	11.0%
Dimethicone PEG-7 Phosphate	8.0%
Mineral Oil	1.0%
N,N-Bis (2 hydroxyethyl) p-phenylenediamine Sulfate	1.47%
2,4-Diaminophenoxyethanol HCl	1.205%

15 [000353] A control swatch was dyed with the mixture of L'Oreal Preference™ base containing the same dyes at same levels as above, mixed 1:1 with L'Oreal Preference™ 20 volume developer. The pH of the final mixture was adjusted to 9.5 using NaOH.

20 [000354] Both swatches were processed for 20 minutes at RT, rinsed for 1 minute (80gph, 32°C), and dried. L*a*b* values were measured before and after coloring using Konica Minolta Spectrophotometer.

[000355] The final ΔL value measurements for the control and

test swatches were -54.32 and -63.25, respectively. More negative ΔL value indicates darker color. The color intensity difference is also visually significant. Therefore the inventive formula deposits greater amounts of color on the hair than the control in the 20 minutes processes.

Example 3

(Low pH Red Binary Color Deposit Study)

[000356] Six swatches of IHIP platinum bleached hair (1cm width, 15cm length) were dyed with 10g of the mixture of the below test dye composition mixed 1:1 with L'Oreal Majicreme™ 20 volume developer.

Ingredients	Example 3
DI Water	Q.S.
Oleamidopropyl Dimethylamine	2.0%
PPG-5 Ceteth-20	24.0%
Dimethicone PEG-7 Phosphate	24.0%
1-hydroxyethyl 4,5 diamino pyrazole sulfate	1.201%
5-amino-o-cresol	0.615%

[000357] Six control swatches were dyed with 10g of the mixture of Redken Shades EQ™ clear base containing the same dyes at same levels as above, mixed 1:1 with Redken Shades EQ™ processing solution.

[000358] Both sets of swatches were processed for 10 and 30 minutes at RT, rinsed for 1 minute (80gph, 32°C), and dried. L*a*b* values were measured before and after coloring using Konica Minolta Spectrophotometer.

[000359] At 10 minutes, Test and Control had ΔE of 42.059 and 38.085, respectively. At 30 minutes, Test and Control had ΔE of 44.570 and 40.537, respectively. Higher the ΔE value

indicates greater color difference. These values are statistically significant at both 10 and 30 minutes. The color intensity difference is also visually significant. Therefore the inventive formula deposits greater amounts of color on the hair than the control in the 10 minutes and 30 minutes processes.

Example 4

(High pH Red Binary Color Deposit Study)

10 [000360] Six swatches of IHIP platinum bleached hair (1cm width, 15cm length) were dyed with 10g of the mixture of the below test dye composition mixed 1:1.07 with L'Oreal INOA™ 20 volume developer.

Ingredients	Example 4
DI Water	Q.S.
Oleamidopropyl Dimethylamine	2.0%
PPG-5 Ceteth-20	14.0%
Dimethicone PEG-7 Phosphate	14.37%
Mineral oil	54.29%
1-hydroxyethyl 4,5 diamino pyrazole sulfate	1.201%
5-amino-o-cresol	0.615%

15

[000361] Six control swatches were dyed with 10g of the mixture of INOA™ clear booster base 1 part and Oleo Gel 2.5 parts, containing the same dyes at same levels as above, mixed 1:1.07 with L'Oreal INOA™ 20 volume developer.

20

[000362] Both sets of swatches were processed for 10 and 30 minutes at RT, rinsed for 1 minute (80gph, 32°C), and dried. L*a*b* values were measured before and after coloring using Konica Minolta Spectrophotometer.

Example 5

(Low pH Blue Binary Color Deposit Study)

[000363] A test swatch of IHIP 90% gray hair (1cm width, 15cm length) was dyed with 20g of the mixture of the below dye composition mixed 1:1 with L'Oreal Majicreme™ 20 volume developer. The pH of the final mixture was adjusted to 6.5 using NaOH.

Ingredients	Example 5
DI Water	Q.S.
PEI-35	0.5%
PPG-5 Cetetj-20	11.0%
Dimethicone PEG-7 Phosphate	8.0%
Mineral Oil	1.0%
N,N-Bis (2-hydroxyethyl) p-phenylenediamine sulfate	1.47%
2,4-Diaminophenoxyethanol HCl	1.205%

10 [000364] At 10 minutes, Test and Control had ΔE of 44.508 and 34.975, respectively. At 30 minutes, Test and Control had ΔE of 48.222 and 35.185, respectively. Higher ΔE value indicates greater color difference. These values are statistically significant at both 10 and 30 minutes. The color intensity difference is also visually significant. Therefore the inventive formula deposits greater amounts of color on the hair than the control in both the 10 minutes and the 30 minutes processes.

20 Example 6

(High pH Blue Binary Color Deposit Study)

[000365] A test swatch of IHIP 90% gray hair (1cm width, 15cm length) was dyed with 20g of the mixture of the below dye composition mixed 1:1 with L'Oreal Majicreme™ 20 volume

developer. The pH of the final mixture was adjusted to 9.5 using NaOH.

Ingredients	Example 6
DI Water	Q.S.
PEI-35	0.5%
PPG-5 Ceteth-20	11.0%
Dimethicone PEG-7 Phosphate	8.0%
Mineral Oil	1.0%
N,N-Bis (2-hydroxyethyl) p-phenylenediamine sulfate	1.47%
2,4-Diamimophenoxyethanol HCl	1.205%

5 [000366] A control swatch was dyed with the mixture of L'Oreal Preference™ base containing the same dyes at same levels as above, mixed 1:1 with L'Oreal Preference™ 20 volume developer. The pH of the final mixture was adjusted to 9.5 using NaOH.

10 [000367] Both swatches were processed for 20 minutes at RT, rinsed for 1 minute (80gph, 32°C), and dried. L*a*b* values were measured before and after coloring using Konica Minolta Spectrophotometer.

15 [000368] The final L value measurements for the control and test swatches were 30.58 and 24.59, respectively. Lower L value indicates darker color. The color intensity difference is also visually significant. Therefore the inventive formula deposits greater amounts of color on the hair than the control in the 20 minutes processes.

Example 7

(Low pH Blue Binary Color Deposit Study)

[000369] A test swatch of IHIP 90% gray hair (1cm width, 15cm
 5 length) was dyed with 20g of the mixture of the below dye
 composition mixed 1:1 with L'Oreal Majicreme™ 20 volume
 developer. The pH of the final mixture was adjusted to 6.5
 using NaOH.

Ingredients	Example 7
DI Water	Q.S.
Behentrimonium Chloride	2.0%
PPG-5 Ceteth-20	16.0%
Dimethicone PEG-7 Phosphate	6.0%
Mineral oil	1.0%
N,N-Bis (2-hydroxyethyl) p-phenylenediamine Sulfate	1.47%
2,4-Diaminophenoxyethanol HCl	1.205%

10 [000370] A control swatch was dyed with the mixture of Redken
 Shades EQ™ clear, containing the same dyes at same levels as
 above, mixed 1:1 with Redken Shades EQ™ Processing solution.
 The pH of the final mixture was adjusted to 6.5 using NaOH.

[000371] Both swatches were processed for 20 minutes at RT,
 15 rinsed for 1 minute (80gph, 32°C), and dried. L*a*b* values
 were measured before and after coloring using Konica Minolta
 Spectrophotometer.

[000372] The final ΔL value measurements for the control and
 test swatches were -54.32 and -65.02, respectively. More
 20 negative ΔL value indicates darker color. The color intensity
 difference is also visually significant. Therefore the
 inventive formula deposits greater amounts of color on the
 hair than the control in the 20 minutes processes.

Example 8

(High pH Blue Binary Color Deposit Study)

[000373] A test swatch of IHIP 90% gray hair (1cm width, 15cm
 5 length) was dyed with 20g of the mixture of the below dye
 composition mixed 1:1 with L'Oreal Majicreme™ 20 volume
 developer. The pH of the final mixture was adjusted to 9.5
 using NaOH.

Ingredients	Example 8
DI Water	Q.S.
Behentrimonium Chloride	2.0%
PPG-5 Ceteth-20	16.0%
Dimethicone PEG-7 Phosphate	6.0%
Mineral Oil	1.0%
N,N-Bis (2-hydroxyethyl) p- phenylenediamine Sulfate	1.47%
2,4-Diaminophenoxyethanol HCl	1.205%

10

[000374] A control swatch was dyed with the mixture of
 L'Oreal Preference™ base containing the same dyes at same
 levels as above, mixed 1:1 with L'Oreal Preference™ 20 volume
 15 developer. The pH of the final mixture was adjusted to 9.5
 using NaOH.

[000375] Both swatches were processed for 20 minutes at RT,
 rinsed for 1 minute (80gph, 32°C), and dried. L*a*b* values
 were measured before and after coloring using Konica Minolta
 20 Spectrophotometer.

[000376] The final ΔL value measurements for the control and
 test swatches were -54.32 and -67.78, respectively. More
 negative ΔL value indicates darker color. The color intensity
 difference is also visually significant. Therefore the

inventive formula deposits greater amounts of color on the hair than the control in the 20 minutes processes.

Example 9

5 (Wet Combing Study)

[000377] Six untreated IHIP regular bleached hair swatches (1 inch width, 5.5 inch length) were measured for Energy Break (the energy needed to comb through the whole hair swatch), using the Instron wet combing machine. The swatches were then
 10 dyed with 15g of the mixture of the below dye composition mixed 1:1 with L'Oreal Preference™ 20 volume developer.

Ingredients	Example 9
DI Water	Q.S.
Behentrimonium Chloride	2.0%
PPG-5 Ceteth-20	16.0%
Dimethicone PEG-7 Phosphate	6.0%
Mineral Oil	1.0%
1-Hydroxyethyl 4,5 Diamino pyrazole sulfate	1.201%
5-amino-o-cresol	0.615%

[000378] The dyed swatches were measured wet for final Energy Break reading. The average Energy break readings of the
 15 untreated and the dyed swatches were 594.87 and 91.08 g-in, respectively. These values are statistically significant. The average percent change in combing is -83.43, therefore the hair is about 83% smoother than before coloring. Thus, the
 20 inventive formula is providing better conditioning to the hair.

Example 10

(Low pH Blue Binary Color Deposit Study)

[000379] A test swatch of IHIP 90% gray hair (1cm width, 15cm

length) was dyed with 20g of the mixture of the below dye composition mixed 1:1 with L'Oreal Majicreme™ 20 volume developer. The pH of the final mixture was adjusted to 6.5 using NaOH.

5

Ingredient	Example 10
DI Water	Q.S.
Lecithin	1.0%
PPG-5 Ceteth-20	11.0%
Dimethicone PEG-7 Phosphate	5.0%
Mineral Oil	1.0%
N,N-Bis (2-hydroxyethyl) p-phenylenediamine Sulfate	1.47%
2,4-Diaminophenoxyethanol HCl	1.205%

[000380] A control swatch was dyed with the mixture of Redken Shades EQ™ clear, containing the same dyes at same levels as above, mixed 1:1 with Redken Shades EQ™ Processing solution.

10 The pH of the final mixture was adjusted to 6.5 using NaOH.

[000381] Both swatches were processed for 20 minutes at RT, rinsed for 1 minute (80gph, 32°C), and dried. L*a*b* values were measured before and after coloring using Konica Minolta Spectrophotometer.

15 [000382] The final ΔL value measurements for the control and test swatches were -54.32 and -65.94, respectively. More negative ΔL value indicates darker color. The color intensity difference is also visually significant. Therefore the inventive formula deposits greater amounts of color on the
20 hair than the control in the 20 minutes processes.

Example 11

(High pH Blue Binary Color Deposit Study)

[00013] A test swatch of IHIP 90% gray hair (1cm width, 15cm length) was dyed with 20g of the mixture of the below dye composition mixed 1:1 with L'Oreal Majicreme™ 20 volume developer. The pH of the final mixture was adjusted to 9.5 using NaOH.

Ingredients	Example 11
DI Water	Q.S.
Lecithin	1.0%
PPG-5 Ceteth-20	11.0%
Dimethicone PEG-7 Phosphate	5.0%
Mineral Oil	1.0%
N,N-Bis (2-hydroxyethyl) p-phenylenediamine Sulfate	1.47%
2,4-Diaminophenoxyethanol HCl	1.205%

10 [000383] A control swatch was dyed with the mixture of L'Oreal Preference™ base containing the same dyes at same levels as above, mixed 1:1 with L'Oreal Preference™ 20 volume developer. The pH of the final mixture was adjusted to 9.5 using NaOH.

15 [000384] Both swatches were processed for 20 minutes at RT, rinsed for 1 minute (80gph, 32°C), and dried. L*a*b* values were measured before and after coloring using Konica Minolta Spectrophotometer.

20 [000385] The final ΔL value measurements for the control and test swatches were -54.32 and -65.10, respectively. More negative ΔL value indicates darker color. The color intensity difference is also visually significant. Therefore the inventive formula deposits greater amounts of color on the hair than the control in the 20 minutes processes.

Example 12

(Low pH Red Shade Color Deposit Study)

[000386] Three test swatches of IHIP Natural White hair (1cm width, 15cm length) were dyed with 20g of the mixture of the below dye composition mixed 1:1 with Redken Shades EQ™ Processing solution.

Ingredient	Example 12
DI Water	Q.S.
Lecithin	1.0%
PPG-5 Ceteth-20	11.0%
Dimethicone PEG-7 Phosphate	5.0%
Mineral Oil	1.0%
Sodium Sulfite	0.25%
Erythrobinic Acid	0.1%
Redken Shades EQ 06R Dyes	2.14%
pH to 6.5+/-0.5 with NaOH	Q.S.

10 [000387] A control swatch was dyed with the mixture of L'Oreal Preference™ base containing the same dyes at same levels as above, mixed 1:1 with L'Oreal Preference™ 20 volume developer. The pH of the final mixture was adjusted to 9.5 using NaOH.

15 [000388] Both swatches were processed for 20 minutes at RT, rinsed for 1 minute (80gph, 32°C), and dried. L*a*b* values were measured before and after coloring using Konica Minolta Spectrophotometer.

20 [000389] The final ΔL value measurements for the control and test swatches were -54.32 and -65.10, respectively. More negative ΔL value indicates darker color. The color intensity difference is also visually significant. Therefore the

inventive formula deposits greater amounts of color on the hair than the control in the 20 minutes processes.

[000390] It will be apparent to those skilled in the art that numerous modifications and variations can be made
5 without departing from the spirit or scope of the invention.

CLAIMS

1. A dyeing aqueous composition for dyeing keratinous substrates comprising, in a cosmetically acceptable medium,
5 a) at least one amine selected from the group comprising fatty monoamine compounds, polyamine compounds having at least three amino groups, fatty quaternary amine compounds, or at least one phospholipid;
10 b) at least one nonionic surfactant;
c) at least one anionic silicone;
d) at least one dye chosen from oxidation dye precursors and direct dyes.
- 15 2. The composition of claim 1, wherein fatty monoamine compounds are chosen from tertiary amidoamine having an alkyl group with from 12 to 22 carbon atoms.
- 20 3. The composition of claim 1 or 2, wherein polyamine compounds having at least three amino groups are chosen from polyethyleneimine and polyvinylamine.
- 25 4. The composition of any one of the preceding claims, wherein fatty quaternary amine compound is behentrimonium chloride.
- 30 5. The composition of any one of the preceding claims, wherein phospholipid is chosen from lecithin and linoleamidopropyl PG-dimonium chloride phosphate.
6. The composition of any one of the preceding claims, wherein (a) is present in an amount of greater than 0 to 30%

by weight, particularly from greater than 0 to about 20% by weight, preferably from 1 to 10% by weight, more particularly from 0.01% by weight to 10% by weight, more preferably from 0.1% to 5% by weight, and even more preferably from 1% to 4%
5 by weight, based on the total weight of the composition.

7. The composition of any one of the preceding claims, wherein (b) has an HLB of at least 8.

10 8. The composition of any one of the preceding claims, wherein (b) is present in an amount of from greater than 0% to 70% by weight, preferably from 0.1% to 50% by weight, and more preferably from 1% to 30% by weight, and even more preferably from 5% to 20% by weight based on the total weight of the
15 composition.

9. The composition of any one of the preceding claims, wherein (c) is chosen from silicone carboxylate, silicone phosphate, silicone sulfate, silicone sulfosuccinate and
20 silicone sulfonate.

10. The composition of any one of the preceding claims, wherein (c) is chosen from silicone carboxylate, silicone phosphate and silicone carboxylate.

25

11. The composition of any one of the preceding claims, wherein (c) is present in an amount of from greater than 0% to 70% by weight, particularly from greater than 0% to 50% weight, preferably from 0.1% to 30% by weight, more preferably from 1% to 30% by weight and more preferably from 0.5% to 20%
30 by weight, based on the weight of the composition as a whole.

12. The composition of any one of the preceding claims,

wherein (d) is chosen from oxidation bases and couplers, and mixtures thereof.

13. The composition of any one of the preceding claims,
5 wherein (d) is chosen from ortho- and para-phenylenediamine oxidation bases, double bases, ortho- and para-aminophenols, heterocyclic bases, as well as salts of addition of these compounds with an acid and meta-aminophenol, meta-phenylenediamine, meta-diphenol, naphthol couplers,
10 heterocyclic couplers and acid salts thereof.

14. The composition of any one of the preceding claim, wherein (d) is chosen from aminophenols and meta-phenylenediamines.

15

15. The composition of any one of the preceding claims, wherein (d) is chosen from direct dyes.

16. The composition of any of the preceding claim, wherein it
20 further comprises at least one thickening agent (e) which is preferably chosen from a polymeric thickener and a non-polymeric thickener.

17. The composition of claim 16, wherein (e) is used in an
25 amount of from greater than 0% to 15% by weight, particularly 0.01 to 10% by weight, preferably 0.1% to 10% by weight, and more preferably from 0.5% to 5% by weight, and even more preferably from 1% to 4% by weight, based on the total weight of the composition.

30

18. The composition of any of the preceding claims, wherein it further comprises at least one alkaline agent (f) which is preferably chosen from organic amines, organic amine salts, ammonium salts, and inorganic bases.

19. The composition of claim 18, wherein the alkaline agent (f) is present from 0.001% to 30% by weight, such as from 0.01% to 20% by weight or from 0.1% to 15% by weight, or from 1% to 10% by weight, based on the total weight of the
5 composition.

20. The composition of any of the preceding claims, wherein it further comprises at least one fatty substance other than a fatty acid (g) and which is preferably chosen from lower
10 alkanes, fatty alcohols, esters of fatty acids, esters of fatty alcohol, non-silicone oils, non-silicone waxes and silicones.

21. The composition of claim 20, wherein (g) is non-silicone.
15

22. The composition of claim 20 or 21, wherein (g) is present in amount of at least 10% by weight, particularly from 10% to 80% by weight, such as from 15% to 65% by weight, further such as from 20% to 55% by weight, based on the total weight of the
20 composition.

23. The composition of any of the preceding claims, wherein it further comprises at least one salt (h) which is preferably chosen from salt compounds of halides, sulfates, phosphates, lactates, acetates, glycinates, aspartates, nitrates, perchlorates, carbonates, hydrogen carbonates, silicates, borates, and carboxylic acids.
25

24. The composition of any of the preceding claims, wherein
30 (h) is sodium sulfate.

25. The composition of claim 23 or 24, wherein (h) is present in an amount ranging from 0.001% to 40% by weight or from

0.05% to 30% by weight, or from 0.1% to 20% by weight, or from 1% to 15% by weight, based on the total weight of the composition.

5 26. The composition of any of the preceding claims, wherein it comprises at least one oxidizing agent (i) which is preferably chosen from peroxides, bromates of alkali metals, ferricyanides of alkali metals, peroxygenated salts, oxidoreduction enzymes, and oxygen in air.

10

27. The composition of claim 26, wherein (i) is hydrogen peroxide.

15 28. The composition of claim 26 or 27, wherein (i) is present in an amount ranging from greater than 0 % by weight to 40 % by weight, or from 0.01 % by weight to 30 % by weight, or from 0.1 % by weight to 20% by weight, or from 1% to 15% by weight, based on the total weight of the composition.

20 29. The composition of any of the preceding claims, wherein the composition further comprises a cationic polymer which may be present in an amount of from greater than 0% to 15%, preferably from 0.5% to 10% by weight, and more preferably from 1% to 5% by weight, based on the total weight of the
25 composition.

30. The composition of any of the preceding claims, wherein the composition is substantially free of ammonia.

30 31. The composition of any of the preceding claims, wherein the pH of the composition is at least 9, preferably from 9 to 11.

32. The composition of any of the claims 1 to 30, wherein the

pH of the composition is less than or equal to 7, preferably from 6 to 7.

33. A method of dyeing keratinous substrates, comprising
5 applying onto the keratinous substrates a dyeing aqueous composition according to any one of the preceding claims.

34. The method of claim 33 further comprising:

- 10 a) providing a pre-treatment composition containing at least one salt; and
b) applying the pre-treatment composition prior to the application of the dyeing aqueous composition, wherein the pretreatment composition comprises at least one salt in a cosmetically acceptable medium.

15

35. A kit for dyeing keratinous substrates, comprising:

- 1) a first unit containing, in a cosmetically acceptable medium a dyeing aqueous composition according to any one of the claims 1 to 25 and 29 to 32; and
20 2) a second unit comprising at least one oxidizing agent.

36. The kit of claim 35, wherein the kit further comprises a third unit containing, in a cosmetically acceptable medium,
25 at least one salt.