

J. MORTON.
Car-Couplings.

No. 134,393.

Patented Dec. 31, 1872.

Fig. 1

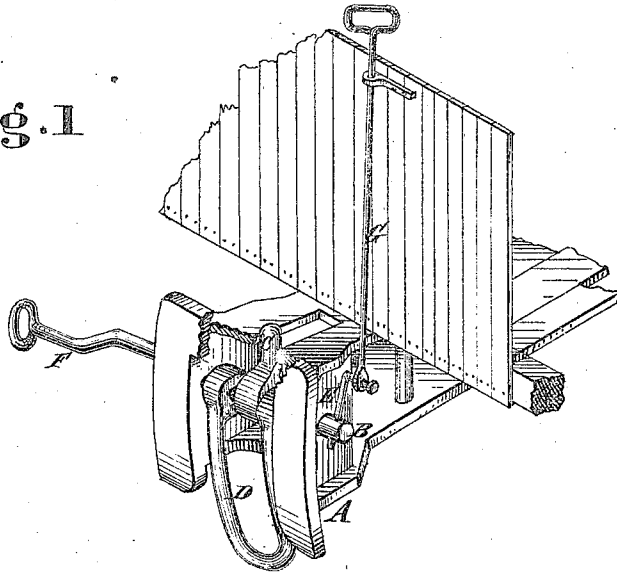

Fig. 2

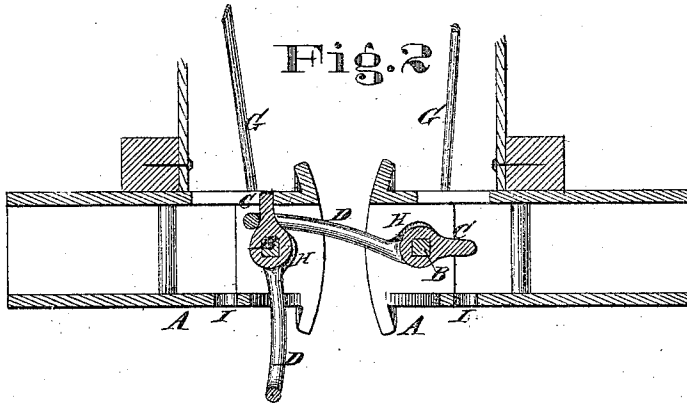
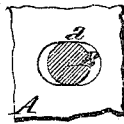

Fig. 3

Attest

Isaac P. Fishburn
Isaac P. Fishburn



Inventor

John Morton
John Morton
By G. Millward
G. Millward
Attorney

J. MORTON.
Car-Couplings.

No. 134,393.

Patented Dec. 31, 1872.

Fig. 4.

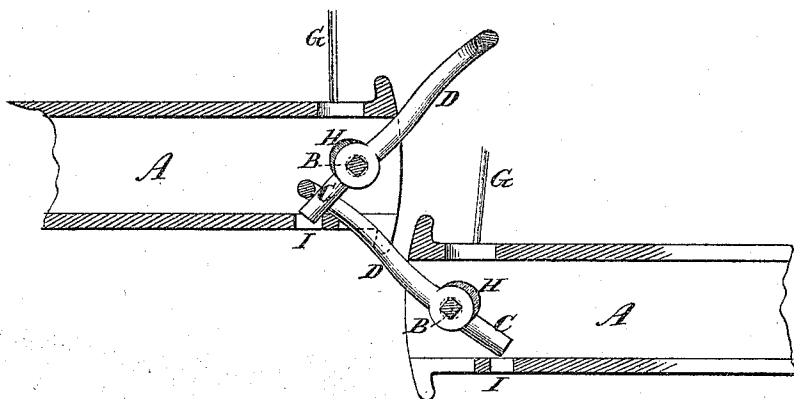

Witnesses.
P. J. Eils
A. Ruppert

John Morton
Inventor.
D. P. Holloway & Co
Attorneys

UNITED STATES PATENT OFFICE.

JOHN MORTON, OF CINCINNATI, OHIO.

IMPROVEMENT IN CAR-COUPINGS.

Specification forming part of Letters Patent No. 134,393, dated December 31, 1872.

To all whom it may concern:

Be it known that I, JOHN MORTON, of Cincinnati, Hamilton county, State of Ohio, have invented certain new and useful Improvements in Car-Couplings, of which the following is a specification:

Nature and Objects of Invention.

This invention relates to that class of car-couplings which embody in their construction a combined and permanently attached link and pin, so arranged relatively that either may act in conjunction with its counter upon an adjacent car for coupling purposes. My improvement consists in fastening both the link and pin fixedly to a shaft, which passes through elongated holes in the sides of the draw-head, allowing for lateral oscillation, and is operated to aid in coupling or uncoupling by means of levers reaching to the side and to the top of the car. The draw-head is also so constructed with reference to the link and pin that the coupling may be effected either above or underneath the shaft of the latter, providing for coupling cars of unequal height.

Description of the Accompanying Drawing.

Figure 1 is a perspective view of the end of a car, showing the draw-head and coupling-link embodying my invention. Fig. 2 is a section of connected draw-heads, illustrating the construction and operation of the coupling. Fig. 3 exhibits the slotted hole in the draw-head through which the shaft of the coupling-link passes. Fig. 4 illustrates the manner of coupling underneath the lifting-shaft.

General Description.

A is the coupling-box or end of the draw-bar. Its front face or bumper has but three sides, as shown, the lower side being omitted simply to permit the permanently-attached coupling-link to swing to a suspended position, as shown in Fig. 2, clearly. The draw-head E is pierced at the sides with oblong holes a, through which the shaft B of the

coupling-link loosely passes. The slotted holes a permit the lateral movement of the link when in a horizontal position for the purpose of providing for irregularities in the construction of the cars, and to permit free action of the cars in turning curves. To the shaft B a short arm, C, is attached rigidly, the end of which is adapted to connect, in the manner shown, with the link of the next car. To the same shaft B the U-shaped coupling-link D is securely connected. The link D and locking-arm C move in unison, and may be, if preferred, made of one piece. They are connected to the crank or handle E or F, or both may be used, so that the brakeman can swing the link to couple or uncouple, by either the handle F or crank E, from the side of the track, by handling the handle direct, or from the platform of the car, by means of rod G. The rod G for freight-cars may extend above the roof of the car. A cam or cams, H, upon the hub of the link D serves to elevate the link of the next car to facilitate uncoupling, by rapidly separating the ends of the link and the arm C.

To uncouple, the cars are backed together and the shaft B of the link which is hanging down is partially rotated, by the means described, so as to carry the arm C out of connection, the rapid disconnection being assisted by the raising of the link which has been coupled in the manner before explained. To couple, the link which is to be used is raised to a horizontal position, and the cars are brought together, when by the gravitation of the other link the connection is effected. When either link becomes disabled a common pin inserted in the hole I may be used to couple the cars. When cars of unequal height are to be coupled together, the link of the higher car may be turned up, so as to let the end of the pin C enter the aperture I in the lower wall of the draw-head, as shown in Fig. 4. This is quite an important feature, because the line of draft may be more nearly maintained in a horizontal line, and the canting strain upon the couplings avoided.

Claims.

1. The combination of draw-head A, lifting-shaft B, and combined link and pin C D, which is fixedly secured to the shaft, and arranged in relation to the apertures in the top and bottom of the draw-head, in the manner and for the purposes set forth.

2. In combination with the elements of the preceding clause, the handle F, as and for the purpose specified.

3. In combination with the elements of the first clause of claims, the crank E and rod G, as and for the purpose set forth.

In testimony of which invention I hereunto set my hand.

JOHN MORTON.

Witnesses:

R. M. HUNTER,
J. L. WARTMANN.