

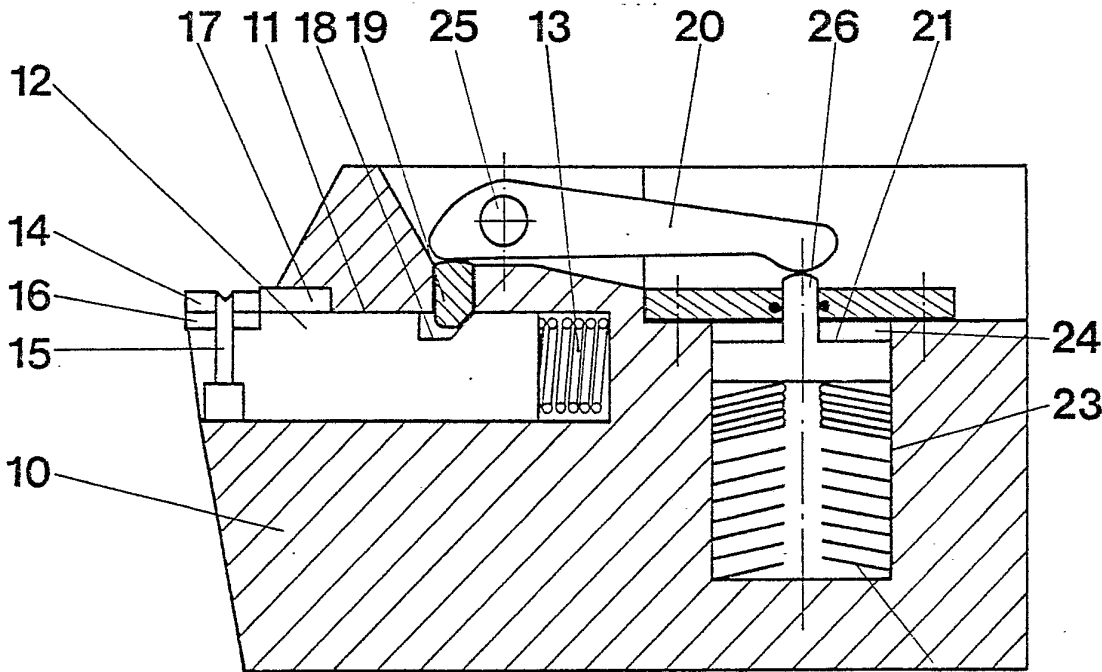

INTERNATIONAL APPLICATION PUBLISHED UNDER THE PATENT COOPERATION TREATY (PCT)

| | | |
|---|-----------|---|
| <p>(51) International Patent Classification³: B23B 29/12</p> | <p>A1</p> | <p>(11) International Publication Number: WO 81/03635 (43) International Publication Date: 24 December 1981 (24.12.81)</p> |
| <p>(21) International Application Number: PCT/SE81/00094 (22) International Filing Date: 25 March 1981 (25.03.81) (31) Priority Application Number: 8002581-0 (32) Priority Date: 3 April 1980 (03.04.80) (33) Priority Country: SE (71) Applicant (for all designated States except US): SECO TOOLS AKTIEBOLAG [SE/SE]; Fack, S-773 01 Fagersta (SE). (72) Inventor; and (75) Inventor/Applicant (for US only): GUSTAFSON, Manfred [SE/SE]; Gamla Fagerstavägen 4, S-773 00 Fagersta (SE).</p> | | <p>(74) Agent: WESTERLUND, Örjan; Sandvik AB, S-811 81 Sandviken (SE). (81) Designated States: DE (European patent), FR (European patent), GB (European patent), JP, US. Published <i>With international search report In English translation (filed in Swedish)</i></p> |

(54) Title: TOOL BLOCK



(57) Abstract

Tool block with a cutting insert holder (12), provided with a cutting insert (14), and a clamping device comprising a pivotally arranged lever (20), one end of which acts on the cutting insert holder (12) while the other end of which cooperates with a spring loaded device (21).

FOR THE PURPOSES OF INFORMATION ONLY

Codes used to identify States party to the PCT on the front pages of pamphlets publishing international applications under the PCT.

| | | | |
|----|------------------------------|----|---------------------------------------|
| AT | Austria | KP | Democratic People's Republic of Korea |
| AU | Australia | LI | Liechtenstein |
| BR | Brazil | LU | Luxembourg |
| CF | Central African Republic | MC | Monaco |
| CG | Congo | MG | Madagascar |
| CH | Switzerland | MW | Malawi |
| CM | Cameroon | NL | Netherlands |
| DE | Germany, Federal Republic of | NO | Norway |
| DK | Denmark | RO | Romania |
| FI | Finland | SE | Sweden |
| FR | France | SN | Senegal |
| GA | Gabon | SU | Soviet Union |
| GB | United Kingdom | TD | Chad |
| HU | Hungary | TG | Togo |
| JP | Japan | US | United States of America |

Tool block

This invention relates to a tool block with a cutting insert holder positioned in the tool block, which holder is provided with a cutting insert.

5 An object of this invention is to design the tool block in such a way that cutting insert exchange and indexing of cutting inserts are considerably simplified.

A preferred embodiment of the invention shall be more closely described in connection to the accompanying drawing.

10 The tool block disclosed in the drawing comprises a longish holding body 10 in which is made a cavity 11 oriented in the longitudinal direction of the holding body 10, in which cavity a cutting insert holder 12 is movably arranged against the action of a spring 13. A cutting insert 14 provided with
15 an aperture is positioned on a locking pin 15 projecting from the insert receiving-site of the cutting insert holder 12. The bottom support surface for the cutting insert 14 is, as usual, formed by a separate support plate 16 of the same form as the cutting insert, while the back support for the
20 cutting insert is formed by a stop 17 positioned on the stationary part of the tool block.

The cutting insert holder 12 is formed with a recess 18 in which a slide 19 arranged substantially parallel with the locking pin 15 shall be positioned. The recess 18 in section
25 has the form of a parallel trapetzoid, the beveled surface of which is the stop surface for the slide 19. In this connection the stop surface of the slide 19 is also beveled in order better to be able to cooperate with the beveled surface of the recess 18. For influence upon the slide there is
30 arranged a lever 20, one end of which acts upon the slide 19, while the other end of which cooperates with a plunger 21 of a pressure-cylinder 24, which is positioned in a cavity 23



oriented substantially parallel with the locking pin 15 in the tool block. In this connection the under-side of the plunger 21 is under influence of a spring device 22.

5 The lever 20 is pivotally positioned on an axis 25, which is fixed in the tool block, which axis is perpendicularly directed to the centre line of the cylinder 24. The two ends of the lever 20 are unattachedly resting against the slide 19 respectively a pin 26 projecting from the plunger 21.

10 When loosening the cutting insert 14 a pressure medium, for instance air, is from a suitable source forced into the cylinder on the upper side of the plunger 21, whereby the plunger 21 is against the action of the spring 22 forced downwards. In this connection the pressure of the lever 20 on the slide 15 19 is reduced, whereby the spring 13 can force out the cutting insert holder 12. In this connection there is formed a gap between the back edge of the cutting insert 14 and the support 17, which is enough in order to be able to remove the cutting insert 14 from its insert receiving site.

20 After the exchange or indexing of the cutting insert the pressure in the cylinder 24 is removed, whereby the plunger 21 is forced upwards by the action of the spring 22. In this connection the pin 26 of the plunger 21 influences the lever 20 so that it pivots around the axis 25 and forces the slide 25 19 into the recess 18 of the cutting insert holder 12. When the slide 19 is forced into the recess 18 the cutting insert holder 12 against the action of the spring 13 will move backwards until the cutting insert 14 is resting against the support 17, the cutting insert being clamped by means of the 30 locking pin 15 fixed to the cutting insert holder and the support 17.

The invention is not limited to the disclosed embodiment but can be varied within the scope of the filed claims.



Thus, as a pressure medium instead of air oil or other
liquideous or gaseous media can be used. Furthermore,
the lever can be fixed to the slide and/or the plunger by
mechanical joints or in another suitable way.

- 5 Moreover, the invention is neither limited to a device for
fastening cutting inserts provided with apertures but the
invention idea is also applicable to cutting inserts without
apertures. In the latter case there cannot be a pin centrally
projecting from the insert receiving site for fastening
10 the cutting insert but this must be done with other arrange-
ments, for instance an edge projecting from the insert
receiving site and positioned in front of the insert.



Claims

1. Tool block comprising a cutting insert holder, provided with a cutting insert, and a clamping device acting on the cutting insert holder for clamping the cutting insert, characterized in that the clamping device comprises a pivotally arranged lever (20), one end of which acts on the cutting insert holder (12), while the other end of which cooperates with a spring loaded device (21), which when clamping the cutting insert (14) influences the lever (20) so that the lever (20) makes a pivoting movement and in its turn influences the cutting insert holder (12), whereby the latter is moved in the tool block so that the cutting insert of the cutting insert holder is clamped against a stop (17) fixed to the tool block, and which device (21) when loosening the cutting insert is subjected to a compressive force against the action of a spring device (22), whereby the influence of the lever (20) on the cutting insert holder (12) is reduced so that the cutting insert holder can be moved in the other direction.
2. Tool block according to claim 1, characterized in that the cutting insert holder (12) is designed with a recess (18) in which a slide (19) cooperating with the lever (20) is to be positioned.
3. Tool block according to claim 1 or 2, characterized in that the cutting insert holder (12) is movably arranged in a cavity (11) oriented in the longitudinal direction of the tool block and is loaded by a spring means (13) which is intended to force the cutting insert holder outwards.
4. Tool block according to anyone of the preceding claims, characterized in that the lever (20) is pivotally arranged on an axis (25).



5. Tool block according to anyone of the preceding claims, characterized in that the spring loaded device (21) comprises a plunger provided with a projecting pin.
- 5 6. Tool block according to claim 5, characterized in that the plunger (21) is movably arranged in a cylinder (24) which is arranged in a cavity (23) in the tool block.
- 10 7. Tool block according to claim 6, characterized in that the compressive force acting on the plunger (21) against the action of the spring device (22) when loosening the cutting insert (14), is formed by injection of a pressure medium, for instance air, into the cylinder (24) on the upper side of the plunger (21).
- 15 8. Tool block according to claims 2, 4, 5 and 6, characterized in that the lever (20) is pivotally arranged on the axis (25) which is perpendicularly directed to the centre-line of the cylinder (24), and that the two ends of the lever (20) are unattachedly resting against the slide (19) and the pin (26) of the plunger (21).
- 20 9. Tool block according to claim 2, characterized in that that part of the recess (18) and that part of the slide (19) cooperating with each other are provided with beveled surfaces.
- 25 10. Tool block according to anyone of the preceding claims, characterized in that the cutting insert (14) is provided with an aperture, and that the cutting insert holder (12) is provided with a projecting locking pin (15) which shall clamp the cutting insert (14) against the stop fixed to the tool block.



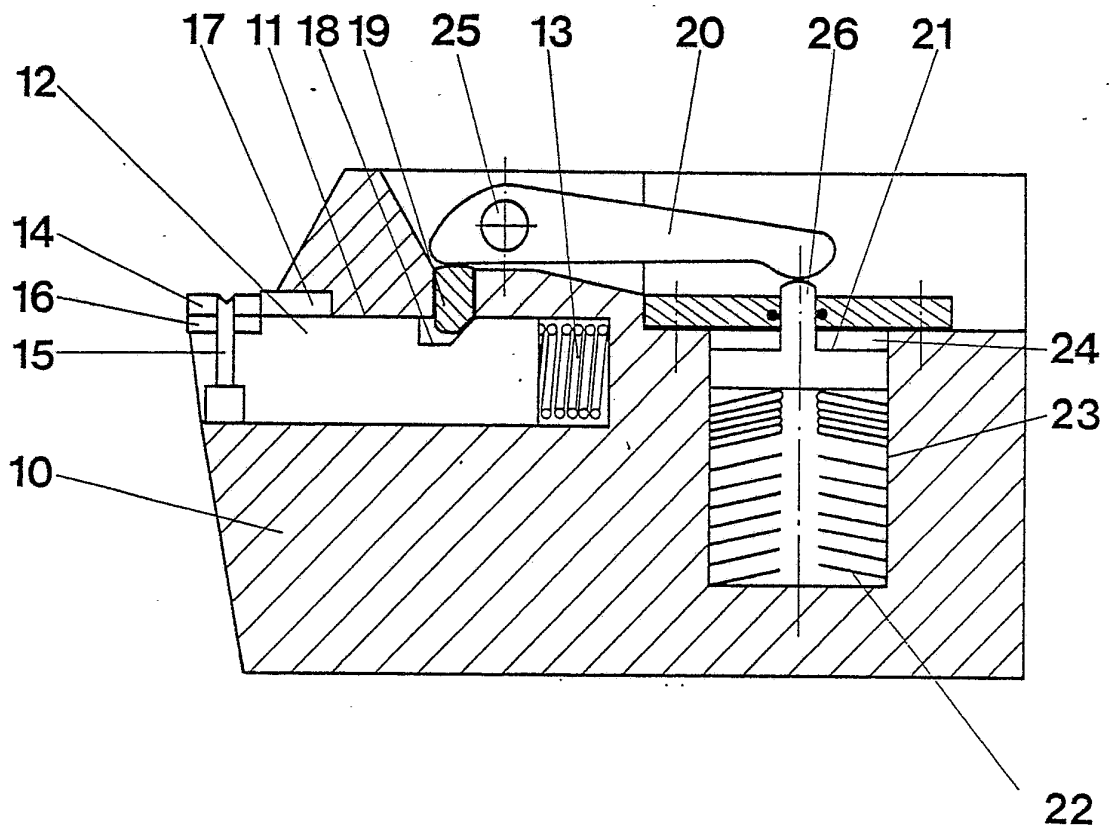
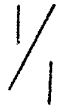

INTERNATIONAL SEARCH REPORT

International Application No PCT/SE81/00094

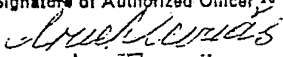
| | | | | |
|--|--|-------------------------------------|---|--|
| I. CLASSIFICATION OF SUBJECT MATTER (If several classification symbols apply, indicate all) ³ | | | | |
| According to International Patent Classification (IPC) or to both National Classification and IPC ³ | | | | |
| B 23 B 29/12 | | | | |
| II. FIELDS SEARCHED | | | | |
| Minimum Documentation Searched ⁴ | | | | |
| Classification System | Classification Symbols | | | |
| IPC ³ | B 23 B 29/00 | | | |
| Documentation Searched other than Minimum Documentation to the extent that such Documents are included in the Fields Searched ⁴ | | | | |
| SE, NO, DK, FI classes as above | | | | |
| III. DOCUMENTS CONSIDERED TO BE RELEVANT ¹⁴ | | | | |
| Category ⁶ | Citation of Document, ¹⁵ with indication, where appropriate, of the relevant passages ¹⁷ | Relevant to Claim No. ¹⁵ | | |
| A | GB, A, 1 510 649 published 1978, May 10, A R Jorgenson | | | |
| A | US, A, 3 838 500 published 1974, October 1, SAO Wirfelt | | | |
| <p>⁶ Special categories of cited documents: ¹⁵</p> <table style="width: 100%; border: none;"> <tr> <td style="width: 50%; border: none;"> <p>"A" document defining the general state of the art</p> <p>"E" earlier document but published on or after the international filing date</p> <p>"L" document cited for special reason other than those referred to in the other categories</p> <p>"O" document referring to an oral disclosure, use, exhibition or other means</p> </td> <td style="width: 50%; border: none;"> <p>"P" document published prior to the international filing date but on or after the priority date claimed</p> <p>"T" later document published on or after the international filing date or priority date and not in conflict with the application, but cited to understand the principle or theory underlying the invention</p> <p>"X" document of particular relevance</p> </td> </tr> </table> | | | <p>"A" document defining the general state of the art</p> <p>"E" earlier document but published on or after the international filing date</p> <p>"L" document cited for special reason other than those referred to in the other categories</p> <p>"O" document referring to an oral disclosure, use, exhibition or other means</p> | <p>"P" document published prior to the international filing date but on or after the priority date claimed</p> <p>"T" later document published on or after the international filing date or priority date and not in conflict with the application, but cited to understand the principle or theory underlying the invention</p> <p>"X" document of particular relevance</p> |
| <p>"A" document defining the general state of the art</p> <p>"E" earlier document but published on or after the international filing date</p> <p>"L" document cited for special reason other than those referred to in the other categories</p> <p>"O" document referring to an oral disclosure, use, exhibition or other means</p> | <p>"P" document published prior to the international filing date but on or after the priority date claimed</p> <p>"T" later document published on or after the international filing date or priority date and not in conflict with the application, but cited to understand the principle or theory underlying the invention</p> <p>"X" document of particular relevance</p> | | | |
| IV. CERTIFICATION | | | | |
| Date of the Actual Completion of the International Search ⁸ | Date of Mailing of this International Search Report ⁸ | | | |
| 1981-06-15 | 1981-06-17 | | | |
| International Searching Authority ¹ | Signature of Authorized Officer ¹⁹ | | | |
| Swedish Patent Office |  A. Klevnäs | | | |