

(No Model.)

L. T. BACKUS.  
CAR COUPLING.

No. 523,564.

Patented July 24, 1894.

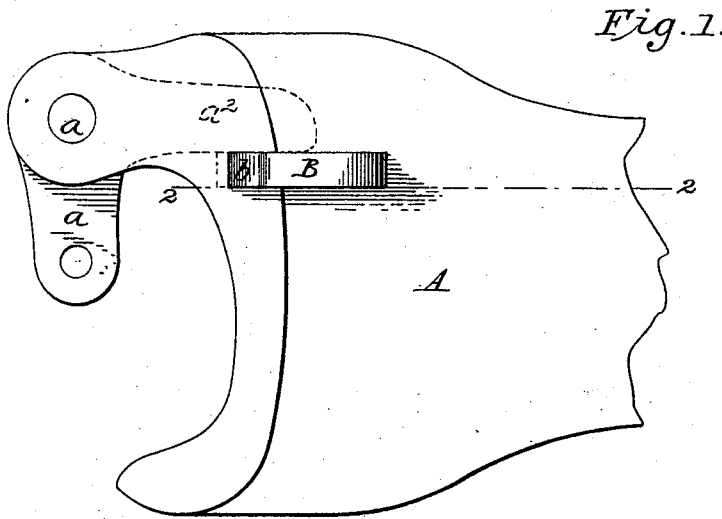

Fig. 1.

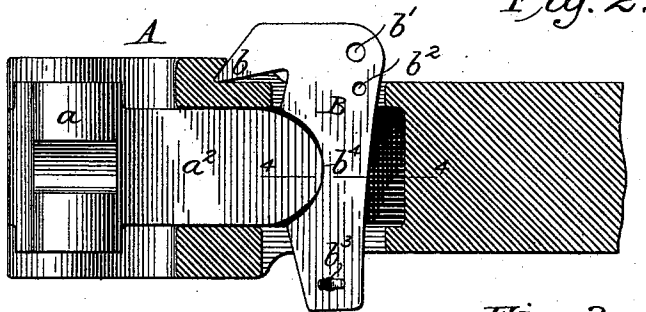

Fig. 2.

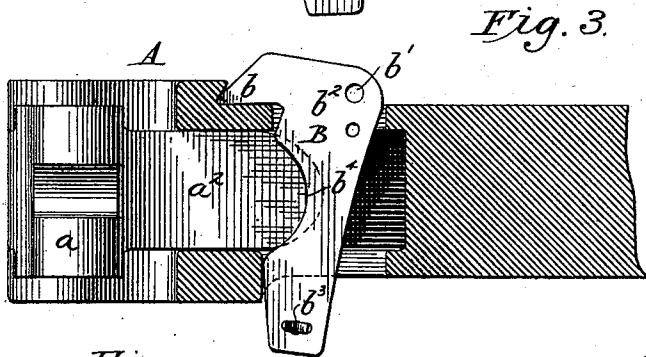

Fig. 3.

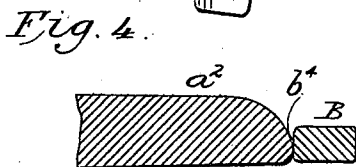

Fig. 4.

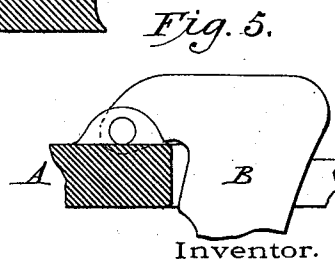

Fig. 5.

Witnesses:

*Sidney P. Hollingsworth*  
*Royal C. Bowen.*

Inventor.

LAWRENCE T. BACKUS,  
by his attorney  
*Arthur W. Harrison*

# UNITED STATES PATENT OFFICE.

LAWRENCE T. BACKUS, OF ATCHISON, KANSAS.

## CAR-COUPLING.

SPECIFICATION forming part of Letters Patent No. 523,564, dated July 24, 1894.

Application filed March 10, 1894. Serial No. 503,153. (No model.)

*To all whom it may concern:*

Be it known that I, LAWRENCE T. BACKUS, of Atchison, in the county of Atchison and State of Kansas, have invented new and useful  
5 Improvements in Car-Couplings; and I do hereby declare the following to be a full, clear, and exact description of said invention, reference being had to the accompanying drawings, and to the letters of reference marked thereon,  
10 which form a part of this specification.

My invention relates to car coupling of the Janney type, and has particular reference to that kind in which there is employed a hook-nose provided with a lever-arm having  
15 an inclined surface at its end adapted to act on an inclined surface of the locking device. Heretofore, such a coupler has been employed in which the locking device is a vertically-movable pin, but with such coupler, considerable  
20 force is necessary to raise the pin to permit the end of the lever-arm to pass behind it.

The object of my invention is to provide a construction by means of which a comparatively light pressure will be sufficient to move  
25 the locking device, and a further object is to provide a locking bearing of the greatest possible extent.

To these ends, my invention consists in the construction and combination of parts as  
30 hereinafter described and pointed out in the claims.

In the accompanying drawings,—Figure 1 is a plan view of my improved coupler. Fig. 2 is a section on line 2—2 of Fig. 1, showing  
35 the lever-arm as displacing the locking-plate. Fig. 3 is a similar section, showing the lever-arm as locked by the plate. Fig. 4 is a section on line 4—4, of Fig. 2. Fig. 5 is a detail of modification hereinafter described.

40 Similar reference letters indicate the same parts in the several views.

The drawhead A is represented as of the usual form of this type of coupler, and having the hook-nose  $a$  pivoted in the head at  $a'$ .  
45 The rearwardly-extending arm  $a^2$  of the hook-nose constitutes the lever-arm, and its end is rounded or convexed in a vertical plane, as shown in Figs. 2 and 3, and also beveled or rounded off laterally and rearwardly, as shown  
50 in Fig. 4, the object of this particular shape

of the end of the lever-arm being hereinafter explained.

The locking-plate B is loosely fitted in a vertical slot in the drawhead, said slot being  
of sufficient width to permit the plate to swing  
55 as hereinafter described. Said plate is provided with a shoulder  $b$  which rests on the top of the drawhead and forms the fulcrum on which said plate swings. An opening  $b'$  is provided for the reception of a chain link  
60 or other device, by means of which the locking-plate may be swung to release the end of the lever-arm, and another smaller hole  $b^2$  may be provided for the reception of a pin to  
65 keep the plate swung aside when it is desired to prevent automatic action of the coupler.

Instead of depending on the shoulder  $b$  for the fulcrum of the locking-plate, I may pivot  
the said plate to the drawhead, as by a pin extending through a hole in the shoulder and  
70 into lugs of the drawhead, as indicated in the detail view Fig. 5. A hole  $b^3$  in the lower end of the plate receives a pin to prevent the plate from becoming accidentally removed  
75 from its slot in the drawhead.

The edge of the plate B is concaved, as at  
 $b^4$ , on the arc of a circle having substantially the same radius as the vertical convexity of  
the lever-arm, and it will thus be seen that a  
more extended bearing of the two parts  
80 against each other is afforded than if the end of the lever-arm and the co-acting portion of the plate were straight.

When two cars are brought together and the hook-noses turn on their pivots in the  
85 usual manner, each lever-arm comes in contact with its locking plate, and owing to the location of the fulcrum of the latter the contact of the two parts first occurs at one end  
90 of the curve or convexity of the lever-arm, and, as the plate is swung aside, the point of contact gradually but quickly moves to the other end of the curve, thus permitting a light pressure to move or swing the locking plate.  
As soon as the end of the lever-arm passes  
95 the edge of the locking-plate, the latter swings back by its own gravity, and overlaps the end of the former throughout the entire length of the curved portions.

It will be readily understood that the lat- rec

eral swing of the locking plate permits a much easier movement and operation than when a pin or bar has to be bodily lifted, and also, that the locking plate presents a broad and strong support against unlocking the coupler.

Having now described my invention, what I claim is—

1. In a car coupling, the combination with the hook having a vertical pivot and a rearwardly-extending arm provided with a beveled end, of the locking plate loosely fitted in a slot of the drawhead, and having the shoulder *b* resting on the top of the drawhead and having a pointed tip entering a recess in the top of said drawhead substantially as described.

2. In a car coupling, the combination with the pivoted hook having an arm provided with a beveled end, the latter being also convexed in a plane parallel with the pivot, of the swinging locking plate having a concave edge opposite the end of said arm, whereby an extended locking bearing is provided, substantially as described.

In testimony whereof I affix my signature in presence of two subscribing witnesses.

LAWRENCE T. BACKUS.

Witnesses:

A. W. HARRISON,  
HARRY Y. DAVIS.