

L. J. ASHLEY.  
SAW FILING MACHINE.  
APPLICATION FILED APR. 6, 1916.

1,232,476.

Patented July 10, 1917.  
2 SHEETS—SHEET 1.

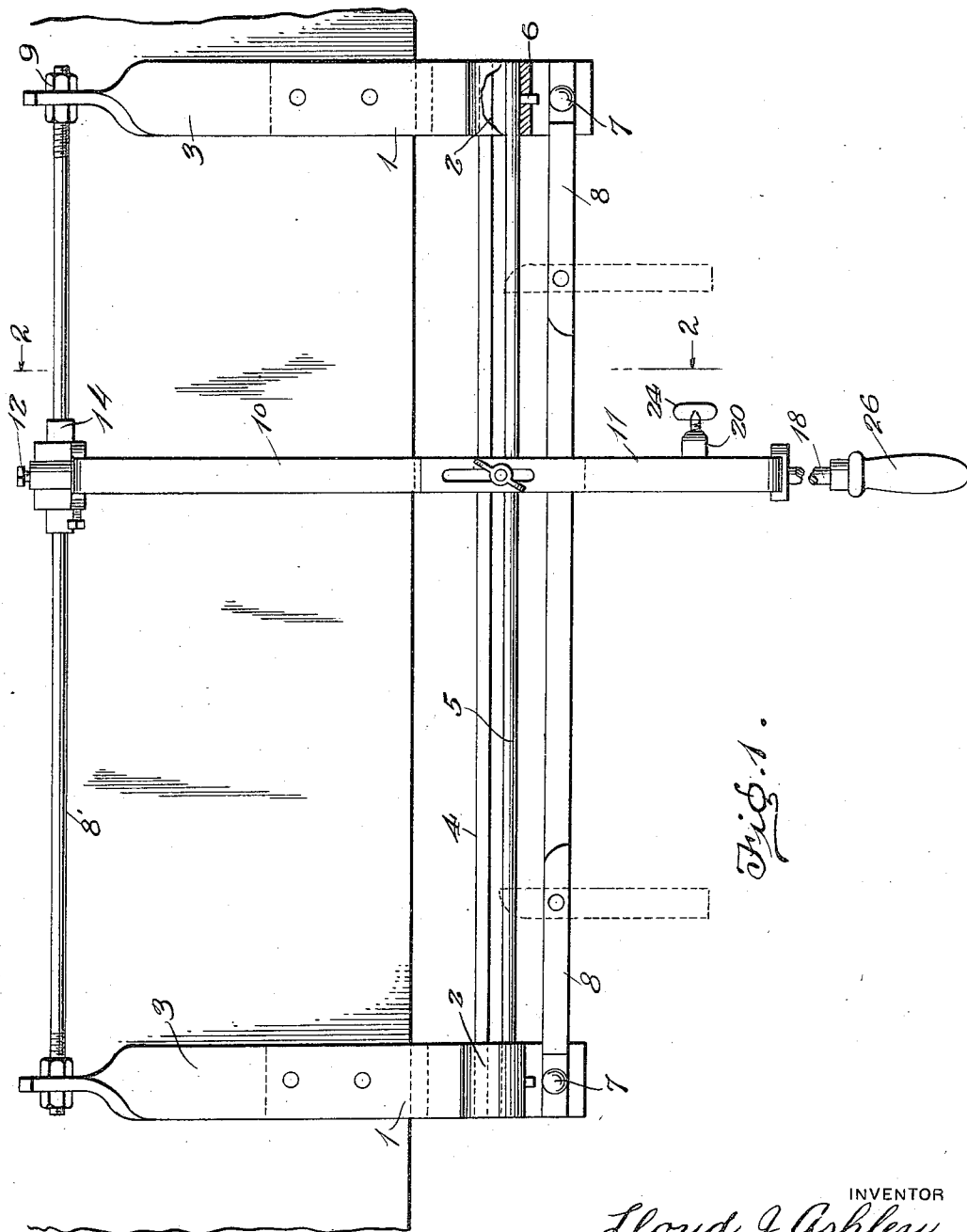

*Fig. 1.*

WITNESSES

*Edw. S. Hall.*  
*Chas. F. Kellogg*

INVENTOR  
*Lloyd J. Ashley.*

BY

*Richard C. Owen.*

ATTORNEY

L. J. ASHLEY.  
 SAW FILING MACHINE.  
 APPLICATION FILED APR. 6, 1916.

1,232,476.

Patented July 10, 1917.

2 SHEETS—SHEET 2.

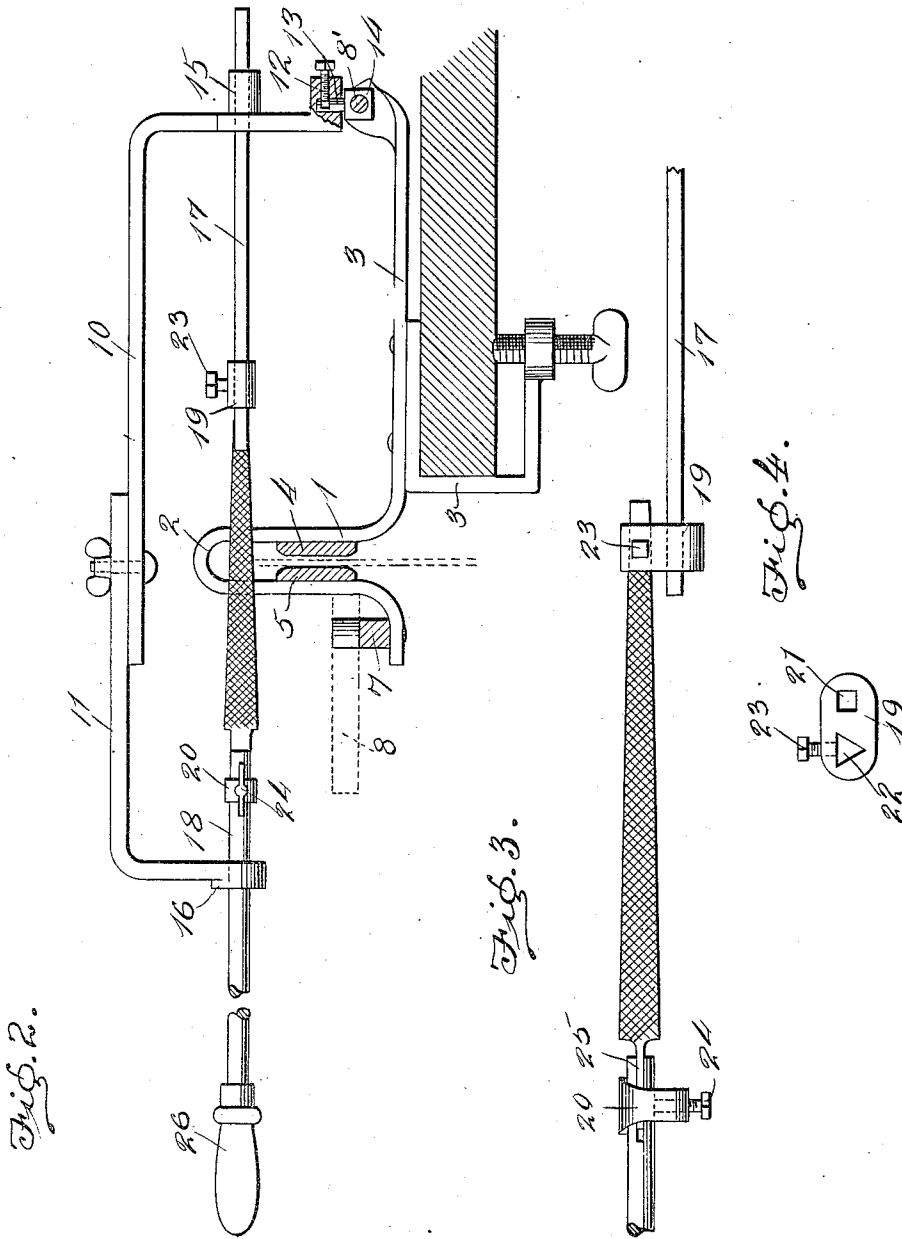

WITNESSES  
 Edw. S. Hall.  
 W. F. Kellogg.

INVENTOR  
 Lloyd J. Ashley.

BY  
 Richard Owen,  
 ATTORNEY

# UNITED STATES PATENT OFFICE.

LLOYD J. ASHLEY, OF MASON CITY, IOWA.

SAW-FILING MACHINE.

1,232,476.

Specification of Letters Patent. Patented July 10, 1917.

Application filed April 6, 1916. Serial No. 89,405.

*To all whom it may concern:*

Be it known that I, LLOYD J. ASHLEY, a citizen of the United States, residing at Mason City, in the county of Cerro Gordo and State of Iowa, have invented certain new and useful Improvements in Saw-Filing Machines, of which the following is a specification.

This invention relates to improvements in saw filing machines, and has for its object the provision of a machine of this character, which is simple in construction, easily manufactured and highly efficient in use.

One object of the invention resides in the provision of the saw supporting member, so constructed, that the same may be quickly operated so as to firmly grip a saw therein, along the entire length of the same.

A further object of the invention, resides in the construction of the file holding frame which is so attached to the saw supporting member, as to have both vertical and horizontal movement, thereby enabling the operator to adjust the file to various angles necessary in the filing of the saw teeth.

A still further object of the invention, resides in constructing the file holding frame, so that the same may be adjusted to various lengths, and by so doing will allow for a longer stroke of the file supporting device.

A still further characteristic of the invention, resides in the construction of the file holder, which is slidably supported by the frame and is so constructed as to prevent the turning of the file while the same is being used.

The improvements in the details and arrangement of parts will be apparent from an inspection of the accompanying drawings, in connection with the specific description hereinafter contained and wherein the preferred embodiment of the invention is disclosed for the purpose of imparting a full understanding of the invention.

In the drawings:—

Figure 1 is a top plan view of the device, with the various parts assembled for operation,

Fig. 2 is a transverse section in elevation taken on line 2—2 of Fig. 1,

Fig. 3 is a fragmentary view showing the construction of the file holding members, and

Fig. 4 is a detailed view showing one of the file holding members in a side elevation.

Referring more specifically to the draw-

ings wherein like reference characters designate corresponding parts in the several views thereof, 1 are spaced supporting members, bent upon themselves at 2 forming a U-shaped construction, and having extensions 3, the purpose of which will be hereinafter described. Secured to one side of the supporting members 1 is a strip 4, forming one part of the jaw for receiving a saw. 5 is a strip arranged adjacent the strip 4 and being provided with, at its outer extremities, lug members 6, adapted to be slidably supported within suitable bearings formed upon the remaining side of the supporting member 1. Secured to the outer end of the supporting members 1 is a lug 7 for receiving a pivotally supporting cam lever 8, whereby the movable strip or jaw 5 may be moved into engagement with a saw and thereby firmly hold the same while the filing operation is being carried out. 8 is a rod mounted in suitable bearings arranged within the extensions 3 of the supporting members 1 and secured thereto, by locking nuts 9. 10 and 11 constitute a frame member for slidably supporting the file, the sections 10 and 11 being slotted at their adjacent ends and provided with a nut and bolt construction whereby the two sections may be secured in an adjusted position. Arranged upon one end of the section 10 of the frame member is a lug portion 12, having provided therein a suitable recess or bearing portion for receiving the part 13 of a connecting member 14. By this construction it will be obvious, that the file supporting frame is supported by the bar 8 in such a manner, that the same may have vertical and horizontal movement, thereby enabling the operator to position the file at the various angles required when filing the same teeth. The lug part 12 may be provided with a set screw for the purpose of engaging the pivot pin 13 and thereby retarding to a certain extent, the horizontal movement of the file supporting frame and further, preventing that member from becoming disengaged with the part 14. Suitable apertures 15 and 16 are arranged in the angular ends of the sections 10 and 11 for supporting slidably file supporting members 17 and 18, which supporting members have arranged, at their adjacent ends file clamping or holding members 19 and 20. The file holding member 19 is in form of a substantial rectangular piece, having provided

therein a squared opening 21 for engaging a supporting member 17, and an opening 22, triangular in shape, or of a shape to conform to the shape of the file being held thereby. The opening 22 is supplied with a set screw 23 for engaging the file and holding that member securely therein. The clamping member 20 is of a loop-like construction, having a set screw 24 passing therethrough, the file in this instance, is held by the slidable supported member, which has a bifurcated end portion 25, adapted to receive the tang of a file, and when that member is in place, the file holding member or clamp 20 is slid over the end of the file tang and the set screw 24 is so adjusted as to bind the bifurcated portion upon the said file tang. 26 is a handle supplied to the slidable supported member 18 whereby the file may be reciprocated.

It will be noted, that by constructing the file holding member 19 with a squared opening 21 adapted to receive the sliding supporting member 17 of a shape, to conform thereto, that the file be prevented from turning upon itself, while being actuated.

An operation of the device may be explained as follows. A file is inserted into the holders 19 and 20 which are attached to their respective supporting members 17 and 18, and assuming that a saw has been clamped between the jaw members 4 and 5 arranged in the supporting strip 1, by means of the cam levers 8, the operator grasps the handle 26 whereby the frame member may be adjusted to the desired position, and when in such a position, he reciprocates the file supporting members, thereby bringing the file into engagement with the various teeth to be filed.

While I have disclosed a specific embodiment of the invention, it will be apparent to persons skilled in the art that the invention is capable of embodiment in other forms and devices differing in detail and arrangement from that shown, as may be in keeping with the hereto appended claims.

Having thus described the invention, what I claim is:—

1. In a saw filing machine, including a

vise, clamps for fastening the vise to a support, an adjustable frame pivotally and slidably supported by the vise, said frame composed of several sections, slots formed in the adjacent ends of the sections and connecting means passing therethrough, the remaining end being bent at an angle thereto and having apertures arranged therein, and a slidable file holder supported by the apertures arranged in the remaining ends.

2. In a filing machine, including spaced supporting members, one portion of the spaced supporting members being bent upon themselves, and saw gripping members received by said bent portions of the supporting member, cam levers supported upon one end of the spaced supporting members for operating the saw gripping members, a connecting rod arranged in the remaining ends of the spaced supporting members, a file supporting frame pivotally and slidably supported by the connecting rod, and slidable file holding members carried by the file supporting frame.

3. A saw filing machine, including a frame, saw retaining means carried by said frame, a second frame pivotally and slidably mounted upon the first-mentioned frame, the second-mentioned frame comprising a plurality of adjustable sections, connecting means engageable with the adjacent ends of said sections, and file holding means slidably mounted upon the second mentioned frame.

4. A saw filing machine, including a frame comprising a plurality of supporting arms having offset looped portions formed in certain of the ends, saw gripping jaws carried by said offset portions, means carried by the arms and engageable with the gripping jaws for closing the same, a rod arranged upon the remaining ends of said supporting arms, and file holding means pivotally and slidably mounted on said rod.

In testimony whereof I affix my signature in presence of two witnesses.

LLOYD J. ASHLEY.

Witnesses:

CHAS. ASHLEY,  
A. C. ASHLEY.