



(51) International Patent Classification:

A61B 5/08 (2006.01) A61B 7/04 (2006.01)
A61B 7/00 (2006.01) G10L 19/00 (2013.01)

(21) International Application Number:

PCT/US2012/060084

(22) International Filing Date:

12 October 2012 (12.10.2012)

(25) Filing Language:

English

(26) Publication Language:

English

(30) Priority Data:

61/547,007 13 October 2011 (13.10.2011) US

(71) Applicant: MASIMO CORPORATION [US/US]; 40 Parker, Irvine, CA 92618 (US).

(72) Inventors: AL-ALI, Ammar; 30312 Via Bella, San Juan Capistrano, CA 92675 (US). LEE, Sung, Uk; 66 Tangerine, Irvine, CA 92618 (US).

(74) Agent: DELANEY, Karoline, A.; Knobbe Martens Olson & Bear, LLP, 2040 Main Street, Fourteenth Floor, Irvine, CA 92614 (US).

(81) Designated States (unless otherwise indicated, for every kind of national protection available):

AE, AG, AL, AM, AO, AT, AU, AZ, BA, BB, BG, BH, BN, BR, BW, BY, BZ, CA, CH, CL, CN, CO, CR, CU, CZ, DE, DK, DM, DO, DZ, EC, EE, EG, ES, FI, GB, GD, GE, GH, GM, GT, HN, HR, HU, ID, IL, IN, IS, JP, KE, KG, KM, KN, KP, KR, KZ, LA, LC, LK, LR, LS, LT, LU, LY, MA, MD, ME, MG, MK, MN, MW, MX, MY, MZ, NA, NG, NI, NO, NZ, OM, PA, PE, PG, PH, PL, PT, QA, RO, RS, RU, RW, SC, SD, SE, SG, SK, SL, SM, ST, SV, SY, TH, TJ, TM, TN, TR, TT, TZ, UA, UG, US, UZ, VC, VN, ZA, ZM, ZW.

(84) Designated States (unless otherwise indicated, for every kind of regional protection available):

ARIPO (BW, GH, GM, KE, LR, LS, MW, MZ, NA, RW, SD, SL, SZ, TZ, UG, ZM, ZW), Eurasian (AM, AZ, BY, KG, KZ, RU, TJ, TM), European (AL, AT, BE, BG, CH, CY, CZ, DE, DK, EE, ES, FI, FR, GB, GR, HR, HU, IE, IS, IT, LT, LU, LV, MC, MK, MT, NL, NO, PL, PT, RO, RS, SE, SI, SK, SM, TR), OAPI (BF, BJ, CF, CG, CI, CM, GA, GN, GQ, GW, ML, MR, NE, SN, TD, TG).

Published:

— with international search report (Art. 21(3))

(54) Title: PHYSIOLOGICAL ACOUSTIC MONITORING SYSTEM

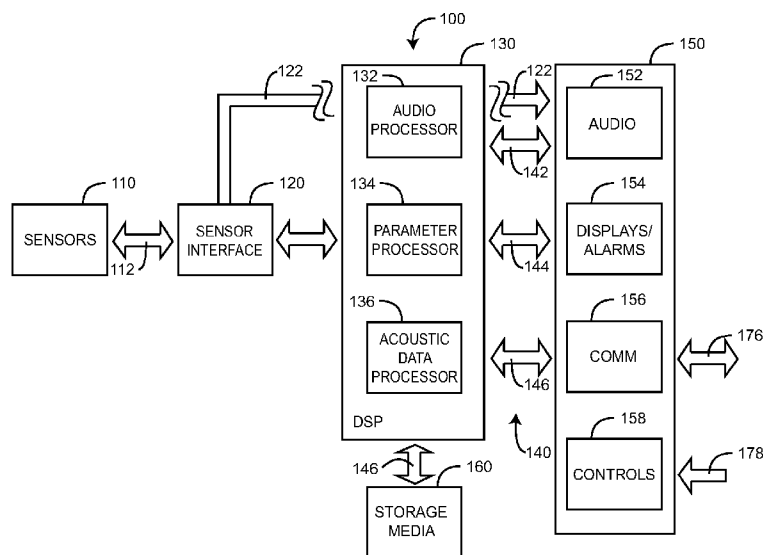

FIG. 1

(57) Abstract: A physiological acoustic monitoring system receives physiological data from an acoustic sensor, down-samples the data to generate raw audio of breathing sounds and compresses the raw audio. The acoustic monitoring system has an acoustic sensor signal responsive to tracheal sounds in a person. An A/D converter is responsive to the sensor signal so as to generate breathing sound data. A decimation filter and mixer down-samples the breathing sound data to raw audio data. A coder/compressor generates compressed audio data from the raw audio data. A decoder/decompressor decodes and decompresses the compressed audio data into decompressed audio data. The decompressed audio data is utilized to generate respiration-related parameters in real-time. The compressed audio data is stored and retrieved so as to generate respiration-related parameters in non-real-time. The real-time and non-real-time parameters are compared to verify matching results across multiple monitors.



PHYSIOLOGICAL ACOUSTIC MONITORING SYSTEM

[0001] This application claims the benefit of priority under 35 U.S.C. § 119(e) of U.S. Provisional Patent Application No. 61/547,007, titled *Physiological Acoustic Monitoring System*, filed October 13, 2011 and is a continuation-in-part of U.S. Patent Application No. 12/905,036 titled *Physiological Acoustic Monitoring System*, which claims the benefit of priority under 35 U.S.C. § 119(e) of U.S. Provisional Patent Application No. 61/252,099, filed October 15, 2009, and U.S. Provisional Patent Application No. 61/391,098, filed October 8, 2010, the disclosures of which are hereby incorporated in their entirety by reference herein. Additionally, this application relates to the following U.S. patent applications, the disclosures of which are incorporated in their entirety by reference herein:

<u>App. No.</u>	<u>Filing Date</u>	<u>Title</u>
60/893853	03/08/07	MULTI-PARAMETER PHYSIOLOGICAL MONITOR
60/893850	03/08/07	BACKWARD COMPATIBLE PHYSIOLOGICAL SENSOR WITH INFORMATION ELEMENT
60/893858	03/08/07	MULTI-PARAMETER SENSOR FOR PHYSIOLOGICAL MONITORING
60/893856	03/08/07	PHYSIOLOGICAL MONITOR WITH FAST GAIN ADJUST DATA ACQUISITION
12/044883	03/08/08	SYSTEMS AND METHODS FOR DETERMINING A PHYSIOLOGICAL CONDITION USING AN ACOUSTIC MONITOR
61/252083	10/15/09	<i>DISPLAYING PHYSIOLOGICAL INFORMATION</i>
12/904823	10/14/10	<i>BIDIRECTIONAL PHYSIOLOGICAL INFORMATION DISPLAY</i>
61/141584	12/30/08	<i>ACOUSTIC SENSOR ASSEMBLY</i>
61/252076	10/15/09	<i>ACOUSTIC SENSOR ASSEMBLY</i>
12/643939	12/21/09	<i>ACOUSTIC SENSOR ASSEMBLY</i>
61/313645	03/12/10	<i>ACOUSTIC RESPIRATORY MONITORING SENSOR HAVING MULTIPLE SENSING ELEMENTS</i>

12/904,890	10/14/10	<i>ACOUSTIC RESPIRATORY MONITORING SENSOR HAVING MULTIPLE SENSING ELEMENTS</i>
12/904,931	10/14/10	<i>ACOUSTIC RESPIRATORY MONITORING SENSOR HAVING MULTIPLE SENSING ELEMENTS</i>
12/904,938	10/14/10	<i>ACOUSTIC RESPIRATORY MONITORING SENSOR HAVING MULTIPLE SENSING ELEMENTS</i>
###/#####	10/14/10	<i>ACOUSTIC PATIENT SENSOR</i>
###/#####	10/14/10	<i>ACOUSTIC RESPIRATORY MONITORING SYSTEMS AND METHODS</i>
61/252062	10/15/09	<i>PULSE OXIMETRY SYSTEM WITH LOW NOISE CABLE HUB</i>
61/265730	12/01/09	<i>PULSE OXIMETRY SYSTEM WITH ACOUSTIC SENSOR</i>
###/#####	10/14/10	<i>PULSE OXIMETRY SYSTEM WITH LOW NOISE CABLE HUB</i>
###/#####	10/14/10	<i>PHYSIOLOGICAL ACOUSTIC MONITORING SYSTEM</i>
61/331087	05/04/10	<i>ACOUSTIC RESPIRATION DISPLAY</i>

[0002] Many of the embodiments described herein are compatible with embodiments described in the above related applications. Moreover, some or all of the features described herein can be used or otherwise combined with many of the features described in the applications listed above.

BACKGROUND OF THE INVENTION

[0003] The "piezoelectric effect" is the appearance of an electric potential and current across certain faces of a crystal when it is subjected to mechanical stresses. Due to their capacity to convert mechanical deformation into an electric voltage, piezoelectric crystals have been broadly used in devices such as transducers, strain gauges and microphones. However, before the crystals can be used in many of these applications they must be rendered into a form which suits the requirements of the application. In many applications, especially those involving the conversion of acoustic waves into a corresponding electric signal, piezoelectric membranes have been used.

[0004] Piezoelectric membranes are typically manufactured from polyvinylidene fluoride plastic film. The film is endowed with piezoelectric properties by stretching the plastic while it is placed under a high-poling voltage. By stretching the film, the film is polarized and the molecular structure of the plastic aligned. A thin layer of conductive metal (typically nickel-copper) is deposited on each side of the film to form electrode coatings to which connectors can be attached.

[0005] Piezoelectric membranes have a number of attributes that make them interesting for use in sound detection, including: a wide frequency range of between 0.001 Hz to 1 GHz; a low acoustical impedance close to water and human tissue; a high dielectric strength; a good mechanical strength; and piezoelectric membranes are moisture resistant and inert to many chemicals.

[0006] Due in large part to the above attributes, piezoelectric membranes are particularly suited for the capture of acoustic waves and the conversion thereof into electric signals and, accordingly, have found application in the detection of body sounds. However, there is still a need for a reliable acoustic sensor, particularly one suited for measuring bodily sounds in noisy environments.

SUMMARY OF THE INVENTION

[0007] An aspect of a physiological acoustic monitoring system receives physiological data from an acoustic sensor, down-samples the data to generate raw audio of breathing sounds and compresses the raw audio. The acoustic monitoring system has an acoustic sensor signal responsive to tracheal sounds in a person. An A/D converter is responsive to the sensor signal so as to generate breathing sound data. A decimation filter and mixer down-samples the breathing sound data to raw audio data. A coder/compressor generates compressed audio data from the raw audio data. A decoder/decompressor decodes and decompresses the compressed audio data into decompressed audio data. The decompressed audio data is utilized to generate respiration-related parameters in real-time. The compressed audio data is stored and retrieved so as to generate respiration-related parameters in non-real-time. The real-time and non-real-time parameters are compared to verify matching results across multiple monitors.

[0008] Another aspect of a physiological acoustic monitoring system inputs an acoustic sensor signal responsive to tracheal sounds of a person and generates breath tags and a respiration rate. The breath tags represent the acoustic envelope of the tracheal sound, and the respiration rate represents the inverse period of the acoustic envelope. The breath tags and respiration rate have a sufficiently low bandwidth to share a data channel with other physiological parameters. In an embodiment, the acoustic monitor has an acoustic sensor input and an A/D converter that digitizes the sensor input and outputs a digitized sensor signal. A decimation filter and mixer reduces the data rate of the digitized sensor signal and outputs a digitized raw audio. An acoustic parameter processor generates a respiration rate and breath tags in response to the digitized raw audio.

[0009] In various embodiments, the acoustic monitoring system has a coder/compressor that compresses the digitized raw audio to generate compressed audio data, which is stored and retrieved so as to generate respiration-related parameters in non-real-time. A decoder/decompressor decompresses the compressed audio data for the acoustic parameter processor. A D/A converter inputs the digitized raw audio and generates a raw audio analog signal for local

playback and listening to the acoustic sensor signal. The compressed audio is transmitted to a remote location as a troubleshooting aid at a remote monitor.

[0010] A further aspect of a physiological acoustic monitoring system inputs a sensor signal responsive to respiratory sounds of a living being, digitizes the sensor signal so as to generate acoustic data, extracts an envelope from the acoustic data, defines an idealized envelope from the extracted envelope, describes the idealized envelope as breath tags and transmits the breath tags over a data channel. In various embodiments, the breath tags are received from the data channel, a reconstructed envelope is synthesized in response to the breath tags and reconstructed acoustic data is generated by filling the envelope with an artificial waveform. In an embodiment, the artificial waveform is white noise.

[0011] An additional aspect of a physiological acoustic monitoring system detects a physiological feature in the extracted envelope and includes the physiological feature in the breath tags. The reconstructed envelope is modified with the detected physiological feature, which may be wheezing or coughing, as examples. The respiratory sounds are approximately reproduced by playing the reconstructed acoustic data on an audio transducer.

[0012] Yet another aspect of a physiological acoustic monitoring system is a sensor signal responsive to respiratory sounds of a living being. An A/D converter digitizes the sensor signal into acoustic data. A parameter generator extracts a respiratory sound envelope from the acoustic data so as to generate a breath tag, which is transmitted over a data channel as a representation of the respiratory sounds. In various embodiments, a remote monitoring station receives the breath tag and a corresponding respiration rate. The monitoring station synthesizes an envelope from the breath tag and the respiration rate and fills the envelope with an artificial waveform so as to generate reconstituted respiratory sounds. In an embodiment, the artificial waveform is white noise.

[0013] In various other embodiments, a decimation filter and mixer down-samples the acoustic data to raw audio data, a D/A converter converts the raw audio data to a raw audio signal and a speaker that plays the raw audio signal. The parameter generator detects a physiological feature in the extracted envelope and includes the

physiological feature in the breath tag. The remote monitor modifies the reconstructed envelope with the detected physiological feature. An audio transducer approximately reproduces the reconstructed acoustic data as compared to the raw audio signal. A compressor generates compressed audio data, which is stored and retrieved so as to generate respiration-related parameters in non-real-time.

BRIEF DESCRIPTION OF THE DRAWINGS

- [0014] FIG. 1 is a general block diagram of a physiological acoustic monitoring system;
- [0015] FIGS. 2A-B are illustrations of dual channel acoustic sensors;
- [0016] FIG. 2A illustrates a neck sensor for physiological measurements and a chest sensor for monaural body sound monitoring;
- [0017] FIG. 2B illustrates a dual acoustic sensor for stereo body sound monitoring;
- [0018] FIGS. 3A-B are top and bottom perspective views of a body sound sensor;
- [0019] FIG. 4 is a general schematic diagram of acoustic and optical sensors and sensor drive elements and a corresponding digital signal processor and I/O drive elements;
- [0020] FIG. 5 is a matrix diagram of processor modules and corresponding functionality;
- [0021] FIG. 6 is a network diagram for a physiological acoustic monitoring system;
- [0022] FIGS. 7A-B are block diagrams of respiration sound generator embodiments;
- [0023] FIGS. 8A-C are graphs illustrating breath tag generator embodiments;
- [0024] FIG. 9 is a block diagram illustrating a physiological parameter processor embodiment for generating acoustic and optical sensor parameters, breath tags and compressed and raw audio outputs;
- [0025] FIGS. 10A-B are a waveform and a block diagram illustrating a respiration beep generator embodiment; and
- [0026] FIG. 11 is a block diagram of a physiological acoustic monitoring system for wireless monitoring applications.

DETAILED DESCRIPTION OF THE PREFERRED EMBODIMENTS

[0027] FIG. 1 generally illustrates a physiological acoustic monitoring system 100 embodiment having one or more sensors 110 in communications with one or more processors 130 via a sensor interface 120. The processors 130 both initiate and respond to input/output 150, including audio output 152, displays and alarms 154, communications 156 and controls 158. In an embodiment, the processors 130 are implemented in firmware executing on one or more digital signal processors (DSP), as described with respect to FIGS. 4-5, below. At least a portion of the sensors 110 generate acoustic signals, which may be directly utilized by the processors 130 or recorded onto or played back from storage media 160 or both.

[0028] The processors 130 include an audio processor 132 that outputs audio waveforms 142, a parameter processor 134 that derives physiological parameters 144 from sensor signals 112 and an acoustic data processor 136 that stores, retrieves and communicates acoustic data 146. Parameters include, as examples, respiration rate, heart rate and pulse rate. Audio waveforms include body sounds from the heart, lungs, gastrointestinal system and other organs. These body sounds may include tracheal air flow, heart beats and pulsatile blood flow, to name a few. Displays allow parameters 144 and acoustic data 146 to be visually presented to a user in various forms such as numbers, waveforms and graphs, as examples. Audio 152 allows audio waveforms to be reproduced through speakers, headphones or similar transducers. Raw audio 122 allows acoustic sensor signals 112 to be continuously reproduced through speakers, headphones or similar transducers, bypassing A/D conversion 120 and digital signal processing 130.

[0029] Storage media 160 allows acoustic data 146 to be recorded, organized, searched, retrieved and played back via the processors 130, communications 156 and audio output 152. Communications 156 transmit or receive acoustic data or audio waveforms via local area or wide area data networks or cellular networks 176. Controls 158 may cause the audio processor 132 to amplify, filter, shape or otherwise process audio waveforms 142 so as to emphasize, isolate, deemphasize or otherwise modify various features of an audio waveform or spectrum. In addition, controls 158 include buttons and switches 178, such as a "push to play" button that

initiates local audio output 152 or remote transmission 176 of live or recorded acoustic waveforms.

[0030] As shown in **FIG. 1**, acoustic data 146 is initially derived from one or more acoustic sensor signals 112, along with, perhaps, other data inputs, such as from optical, blood pressure, EEG and ECG sensors, to name a few. The acoustic data 146 provides audio outputs 142, including audio respiration indicators, described with respect to FIGS. 7-10, below. The acoustic data 146, when analyzed, provides physiological parameters 144 that provide an indication of patient status, such as respiration rate or heart rate. Such analyses may result in visual or audible alerts or alarms 154 that are viewed locally or via notifications transmitted over local or wide area networks 176 to medical staff or other persons. Acoustic data 146 is utilized in real time or stored and retrieved for later use. Acoustic data 146 may be written on various storage media 160, such as a hard drive, and organized for convenient search and retrieval. In an embodiment, acoustic data 146 is advantageous organized on one or more hard drives as virtual magnetic tape so as to more easily manage, search, retrieve and playback acoustic data volumes. Further, the virtual tape volumes and/or the acoustic data itself may be entered into a database and organized as an acoustic library according to various search parameters including patient information, dates, corresponding physiological parameters and acoustic waveform features, to name a few. Applications for a physiological acoustic monitoring system include auscultation of body sounds by medical staff or by audio processors or both; SIDS monitoring; heart distress monitoring including the early detection and mitigation of myocardial infarction and cardiopulmonary arrest, as examples; and elder care, to name a few.

[0031] In an embodiment, sensor sounds 142 may be continuously "piped" to a remote device/listener or a central monitor or both. Listening devices may variously include pagers, cell phones, PDAs, electronic pads or tablets and laptops or other computers to name a few. Medical staff or other remote listeners are notified by the acoustic monitoring system according to flexible pre-programmed protocols to respond to the notification so as to hear breathing sounds, voice, heart sounds or other body sounds.

[0032] FIGS. 2A-B illustrate physiological acoustic monitoring system 200 embodiments each having dual channel acoustic sensors 201, 202 in communications with a physiological monitor 205. As shown in **FIG. 2A**, a first acoustic sensor 210 is utilized for deriving one or more physiological parameters, such as respiration rate. A second acoustic sensor 220 is utilized to continuously monitor body sounds. In an embodiment, the second acoustic sensor 220 has a different color or shape than the first acoustic sensor 210 so as to identify the sensor as a body sound listening device rather than an acoustic sensing device for determining a physiological parameter. In an embodiment, the body sound sensor 220 is placed over the heart to allow the monitoring of heart sounds or for determination of heart rate. In an embodiment, the body sound sensor 220 generates a signal that bypasses monitor digitization and signal processing so as to allow continuous listening of the unprocessed or "raw" body sounds. In particular, the first acoustic sensor 210 is neck-mounted so as to determine one or more physiological parameters, such as respiration rate. The second acoustic sensor 220 is chest-mounted for monaural heart sound monitoring. As shown in **FIG. 2B**, first and second acoustic sensors 260, 270 are mounted proximate the same body site but with sufficient spatial separation to allow for stereo sensor reception. In this manner, the listener can more easily distinguish and identify the source of body sounds.

[0033] FIGS. 3A-B illustrate a body sound sensor 300 having acoustic 310, interconnect (not visible) and attachment 350 assemblies. The acoustic assembly 310 has an acoustic coupler 312 and a piezoelectric subassembly 314. The acoustic coupler 312 generally envelops or at least partially covers some or all of the piezoelectric subassembly 314. The piezoelectric subassembly 314 includes a piezoelectric membrane and a support frame (not visible). The piezoelectric membrane is configured to move on the frame in response to acoustic vibrations, thereby generating electrical signals indicative of body sounds. The acoustic coupler 312 advantageously improves the coupling between the acoustic signal measured at a skin site and the piezoelectric membrane. The acoustic coupler 312 includes a contact portion 316 placed against a person's skin.

[0034] Further shown in **FIGS. 3A-B**, the acoustic assembly 310 communicates with the sensor cable 340 via the interconnect assembly. In an embodiment, the interconnect assembly is a flex circuit having multiple conductors that are adhesively bonded to the attachment assembly 350. The interconnect assembly has a solder pad or other interconnect to interface with the sensor cable 340, and the attachment assembly 350 has a molded strain relief for the sensor cable. In an embodiment, the attachment assembly 350 is a generally circular, planar member having a top side 3511, a bottom side 352, and a center. A button 359 mechanically couples the acoustic assembly 310 to the attachment assembly center so that the acoustic assembly 310 extends from the bottom side 352. The sensor cable 340 extends from one end of the interconnect and attachment assemblies to a sensor connector at an opposite end so as to provide communications between the sensor and a monitor, as described in further detail with respect to, below. In an embodiment, an adhesive along the bottom side 352 secures the acoustic assembly 310 to a person's skin, such as at a neck, chest, back, abdomen site. A removable backing can be provided with the adhesive to protect the adhesive surface prior to affixing to a person's skin. In other embodiments, the attachment assembly 350 has a square, oval or oblong shape, so as to allow a uniform adhesion of the sensor to a measurement site. In a resposable embodiment, the attachment assembly 350 or portions thereof are removably detachable and attachable to the acoustic assembly 310 for disposal and replacement. The acoustic assembly 310 is reusable accordingly.

[0035] **FIG. 4** illustrates acoustic 401 and optical 402 sensors and sensor drive elements 403 and a corresponding digital signal processor 440 and I/O drive elements 404. A multi-acoustic sensor configuration 401 includes a power interface 413, piezo circuits 416 and a piezoelectric membrane 417 corresponding to each sensor head 406, 407. The piezoelectric membrane 417 senses vibrations and generates a voltage in response to the vibrations, as described with respect to the sensor of **FIGS. 3A-B**, above. The signal generated by the piezoelectric membrane is communicated to the piezo circuit 416, described immediately below, and transmits the signal to the monitor 205 (**FIG. 2A**) for signal conditioning and processing. The piezo circuit 416

decouples the power supply 413 and performs preliminary signal conditioning. In an embodiment, the piezo circuit 416 includes clamping diodes to provide electrostatic discharge (ESD) protection and a mid-level voltage DC offset for the piezoelectric signal to ride on, to be superimposed on or to be added to. The piezo circuit may also have a high pass filter to eliminate unwanted low frequencies such as below about 100 Hz for breath sound applications, and an op amp to provide gain to the piezoelectric signal. The piezo circuit 416 may also have a low pass filter on the output of the op amp to filter out unwanted high frequencies. In an embodiment, a high pass filter is also provided on the output in addition to or instead of the low pass filter. The piezo circuit may also provide impedance compensation to the piezoelectric membrane, such as a series/parallel combination used to control the signal level strength and frequency of interest that is input to the op amp. In one embodiment, the impedance compensation is used to minimize the variation of the piezoelectric element output. The impedance compensation can be constructed of any combination of resistive, capacitive and inductive elements, such as RC or RLC circuits.

[0036] As shown in **FIG. 4**, a physiological acoustic monitor 400 embodiment drives and processes signals from a multi-acoustic sensor 401 and an optical sensor 402. The monitor 400 includes one or more acoustic front-ends 421, 422, an analog-to-digital (A/D) converter 431, an audio driver 470 and a digital signal processor (DSP) 440. The DSP 440 can comprise a wide variety of data and/or signal processors capable of executing programs for determining physiological parameters from input data. An optical front-end 425, digital-to-analog (D/A) converters 434 and an A/D converter 435 drive emitters 408 and transform resulting composite analog intensity signal(s) from light sensitive detector(s) 409 received via a sensor cable 410 into digital data input to the DSP 440. The acoustic front-ends 421, 422 and A/D converter 431 transform analog acoustic signals from piezoelectric elements 401 into digital data input to the DSP 440. The A/D converter 431 is shown as having a two-channel analog input and a multiplexed digital output to the DSP. In another embodiment, each front-end, communicates with a dedicated single channel A/D converter generating two independent digital outputs to the DSP.

An acoustic front-end 421 can also feed an acoustic sensor signal 411 directly into an audio driver 470 for direct and continuous acoustic reproduction of an unprocessed (raw) sensor signal by a speaker, earphones or other audio transducer 462, as described with respect to FIG. 9, below.

[0037] Also shown in **FIG. 4**, the physiological acoustic monitor 400 may also have an instrument manager 450 that communicates between the DSP 440 and input/output 460. One or more I/O devices 460 have communications with the instrument manager 450 including displays, alarms, user I/O and instrument communication ports. Alarms 466 may be audible or visual indicators or both. The user I/O 468 may be, as examples, keypads, touch screens, pointing devices or voice recognition devices, to name a few. The displays 464 may be indicators, numerics or graphics for displaying one or more of various physiological parameters or acoustic data. The instrument manager 450 may also be capable of storing or displaying historical or trending data related to one or more of parameters or acoustic data.

[0038] Further shown in **FIG. 4**, the physiological acoustic monitor 400 may also have a "push-to-talk" feature that provides a "listen on demand" capability. That is, a button 468 on the monitor is pushed or otherwise actuated so as to initiate acoustic sounds to be sent to a speaker, handheld device, or other listening device, either directly or via a network. The monitor 400 may also has a "mode selector" button or switch 468 that determines the acoustic content provided to a listener, either local or remote. These controls may be actuated local or at a distance by a remote listener. In an embodiment, push on demand audio occurs on an alarm condition in lieu of or in addition to an audio alarm. Controls 468 may include output filters like on a high quality stereo system so that a clinician or other user could selectively emphasize or deemphasize certain frequencies so as to hone-in on particular body sounds or characteristics.

[0039] In various embodiments, the monitor 400 may be one or more processor boards installed within and communicating with a host instrument. Generally, a processor board incorporates the front-end, drivers, converters and DSP. Accordingly, the processor board derives physiological parameters and

communicates values for those parameters to the host instrument. Correspondingly, the host instrument incorporates the instrument manager and I/O devices. A processor board may also have one or more microcontrollers (not shown) for board management, including, for example, communications of calculated parameter data and the like to the host instrument. A processor board embodiment is described with respect to FIG. 9, below.

[0040] Communications 469 may transmit or receive acoustic data or audio waveforms via local area or wide area data networks or cellular networks. Controls may cause the audio processor to amplify, filter, shape or otherwise process audio waveforms so as to emphasize, isolate, deemphasize or otherwise modify various features of the audio waveform or spectrum. In addition, switches, such as a "push to play" button can initiate audio output of live or recorded acoustic data. Controls may also initiate or direct communications.

[0041] FIG. 5 illustrates processor modules 500 that may execute on a DSP 440 (FIG. 4) and/or instrument manager 450 (FIG. 4) in various physiological acoustic monitoring system embodiments and the corresponding functionality of these modules. Module functionality includes processing sensor input 510, storage 520 and playback 530 of acoustic data, acoustic data analysis 540, communication of acoustic data and derived physiological parameters 550 and specific applications 560. Sensor input 510 related modules include dynamic range 512 and noise reduction 513. Dynamic range 512 functionality is described with respect to the processor board codec and FIG. 9, below. Storage 520 related modules include virtual tape 523 and database 524 functionality, described with respect to FIG. 6, below. Playback 530 functionality includes audio filters 532, sound reproduction 534 including mono/ stereo/ quadraphonic 533 modes and auscultation 535 enhancement. Analysis 540 related modules include audio parameters 542, multi-sensor parameters 543 and corresponding alarms 544. Communications 550 related modules include cellular 553, wireless 554 and network 555 modes. Wireless is described with respect to FIG. 11, below, and cellular 553 and networks 555 are described with respect to FIG. 6, below. Applications 560 include elder care 561 and SIDS 562, described with respect to FIG. 12, below.

[0042] FIG. 6 illustrates a physiological acoustic monitoring system 600 embodiment having a shared or open network architecture interconnecting one or more physiological monitors 610, monitoring stations 620 and mass storage 660. This interconnection includes proximity wireless devices 612 in direct wireless communication with a particular physiological monitor 610; local wireless devices 632 in communications with the monitors 610 via a wireless LAN 630; and distant wired or wireless devices 642, 652 in communications with the monitors 610 via WAN, such as Internet 640 or cellular networks 650. Communication devices may include local and remote monitoring stations 620 and wired or wireless communications and/or computing devices including cell phones, lap tops, pagers, PDAs, tablets and pads, to name a few. Physiological information is transmitted/received directly to/from end users over LAN or WAN. End users such as clinicians may carry wireless devices 632 in communications with the WLAN 630 so as to view in real-time physiological parameters or listen to audio data and waveforms on demand or in the event of an alarm or alert.

[0043] The network server 622 in certain embodiments provides logic and management tools to maintain connectivity between physiological monitors, clinician notification devices and external systems, such as EMRs. The network server 622 also provides a web based interface to allow installation (provisioning) of software related to the physiological monitoring system, adding new devices to the system, assigning notifiers to individual clinicians for alarm notification, escalation algorithms in cases where a primary caregiver does not respond to an alarm, interfaces to provide management reporting on alarm occurrences and internal journaling of system performance metrics such as overall system uptime. The network server 622 in certain embodiments also provides a platform for advanced rules engines and signal processing algorithms that provide early alerts in anticipation of a clinical alarm.

[0044] As shown in FIG. 6, audio data and corresponding audio files are advantageously stored on virtual tape 662, which provides the storage organization of tape cartridges without the slow, bulky, physical storage of magnetic tape and the corresponding human-operator intervention to physically locate and load physical

cartridges into an actual tape-drive. A virtual tape controller 662 emulates standard tape cartridges and drives on modern, high capacity disk drive systems, as is well-known in the art. Accordingly, virtual "audio tapes" appear the same as physical tapes to applications, allowing the use of many existing cartridge tape storage, retrieval and archival applications. Further, while the upper-limit of a physical tape cartridge may be a few hundred megabytes, a virtual tape server 662 can be configured to provide considerably larger "tape" capacity. Mount-time is near-zero for a virtual tape and the data is available immediately. Also, while traditional physical tape systems have to read a tape from the beginning, moving sequentially through the files on the tape, a virtual drive can randomly access data at hard-disk speeds, providing tape I/O at disk access speeds.

[0045] Additionally shown in **FIG. 6**, a sound processing firmware module of certain embodiments accesses a database 670 of sound signatures 660 and compares the received signal with the entries in the database to characterize or identify sounds in the received signal. In another embodiment, the sound processing module generates and/or accesses a database 670 of sound signatures specific to a patient, or specific to a particular type of patient (e.g., male/female, pediatric/adult/geriatric, etc.). Samples from a person may be recorded and used to generate the sound signatures. In some embodiments, certain signal characteristics are used to identify particular sounds or classes of sounds. For example, in one embodiment, signal deviations of relatively high amplitude and or sharp slope may be identified by the sound processing module. Sounds identified in various embodiments by the sound processing module include, but are not limited to, breathing, speech, choking, swallowing, spasms such as larynx spasms, coughing, gasping, etc.

[0046] Once the sound processing module characterizes a particular type of sound, the acoustic monitoring system can, depending on the identified sound, use the characterization to generate an appropriate response. For example, the system may alert the appropriate medical personnel to modify treatment. In one embodiment, medical personnel may be alerted via an audio alarm, mobile phone call or text message, or other appropriate means. In one example scenario, the

breathing of the patient can become stressed or the patient may begin to choke due to saliva, mucosal, or other build up around an endotracheal tube. In an embodiment, the sound processing module can identify the stressed breathing sounds indicative of such a situation and alert medical personnel to the situation so that a muscle relaxant medication can be given to alleviate the stressed breathing or choking.

[0047] According to some embodiments, acoustic sensors described herein can be used in a variety of other beneficial applications. For example, an auscultation firmware module may process a signal received by the acoustic sensor and provide an audio output indicative of internal body sounds of the patient, such as heart sounds, breathing sounds, gastrointestinal sounds, and the like. Medical personnel may listen to the audio output, such as by using a headset or speakers. In some embodiments the auscultation module allows medical personnel to remotely listen for patient diagnosis, communication, etc. For example, medical personnel may listen to the audio output in a different room in a hospital than the patient's room, in another building, etc. The audio output may be transmitted wirelessly (e.g., via Bluetooth, IEEE 802.11, over the Internet, etc.) in some embodiments such that medical personnel may listen to the audio output from generally any location.

[0048] FIGS. 7A-B illustrate sound processing embodiments 701, 702 for generating an audio output for an acoustic sensor. As shown in **FIG. 7A**, in one embodiment, acoustic sensor data is A/D converted 710, down-sampled with a decimation filter 720 and compressed 730. The compressed audio data 732 is transmitted to a monitor, which decompresses the data 740 and outputs it to a speaker 742 or similar audio transducer. However, compressed audio data 732 from a physiological acoustic sensor has too high a bit rate to transmit over monitor data channels shared with other physiological processors or patient networks shared by multiple patient monitors all communicating physiological parameters, waveforms and other real-time medical data. Acoustic sensor data rates are described in further detail with respect to FIG. 9, below.

[0049] As shown in **FIG. 7B**, an envelope-based sound processing 702 embodiment advantageously allows respiration-related acoustic data to be

transmitted at significantly reduced data rates compared with data compression so as to allow shared transmission over monitor data channels (990 FIG. 9) and patient networks. Respiration-related acoustic data is A/D converted 710 and input to an envelope detector 750. The detected envelopes are idealized and represented by a small number set or "tag" corresponding to each breath. In an embodiment, a breath tag represents the time-of-occurrence of the breath envelope peak for each inspiration and expiration cycle. These breath tags 760 are then transmitted over standard multiple parameter patient monitor data channels and/or patient networks. At the receiving end, a patient monitor, multiple patient monitoring system or like monitoring device synthesizes the envelopes 770 from the breath tags 760 according to the respiration rate (RR). The envelopes 770 are then filled with white noise 780 so as to simulate the original respiration acoustic data 782.

[0050] FIGS. 8A-C further illustrate envelope processing for acoustic sensor data. **FIG. 8A** illustrates a representative acoustic signal 801 derived by a neck sensor detecting vibrations resulting from tracheal air flow during respiration. A breath sound 810 has an envelope 820 "pulse" corresponding to either inhalation or exhalation. An envelope detector 750 (FIG. 7B) generates breath tags that numerically describe the envelope 820. As shown in **FIG. 8B**, in one embodiment, breath tags describe an idealized envelope 830. For example, a breath tag may be an amplitude value and a duration value for each idealized pulse. In other embodiments, a breath tag may include leading/trailing slope values for a pulse 830. As shown in **FIG. 8C**, in other embodiments, breath tags include detected envelope features 842, 843, 844 that are characteristic of known acoustically-related phenomena such as wheezing or coughing, as examples. At a receiving device, envelop synthesis 770 (FIG. 7B) reproduces an envelope 830, 840 and fills the envelope with an artificial waveform, such as white noise. This reconstructed or simulated breath signal is then output to a speaker or similar device. In other embodiments, breath tags are transmitted over a network to a remote device, which reconstructs breathing waveforms from the breath tags in like manner.

[0051] In various other embodiments, acoustic breathing waveforms are detected by an acoustic sensor, processed, transmitted and played on a local or remote

speaker or other audio output from actual (raw) data, synthetic data and artificial data. Actual data may be compressed, but is a nearly complete or totally complete reproduction of the actual acoustic sounds at the sensor. Synthetic data may be a synthetic version of the breathing sound with the option of the remote listener to request additional resolution. Artificial data may simulate an acoustic sensor sound with minimal data rate or bandwidth, but is not as clinically useful as synthetic or actual data. Artificial data may be, for example, white noise bursts generated in sync with sensed respiration. Synthetic data is something between actual data and artificial data, such as the acoustic envelope process described above that incorporates some information from the actual sensor signal. In an embodiment breath sounds are artificially hi/lo frequency shifted or hi/lo volume amplified to distinguish inhalation/exhalation. In an embodiment, dual acoustic sensors placed along the neck are responsive to the relative time of arrival of tracheal sounds so as to distinguish inhalation and exhalation in order to appropriately generate the hi/lo frequency shifts. Raw and compressed acoustic respiration data is described with respect to FIG. 9, below. Artificial data “breath beeps” are described with respect to FIGS. 10A-B, below.

[0052] FIG. 9 illustrates a processor board 900 embodiment of an acoustic monitoring system that generates both optical and acoustic data. An optical portion has D/A converters 958 responsive to emitter drives 954 and an emitter control 950 so as to alternately activate optical sensor 902 LEDs of multiple wavelengths so as to illuminate blood perfused tissue. An A/D converter 960 and demodulator 964 are responsive to sensor 902 detectors so as to generate plethysmographic data 968 to a digital signal processor (DSP) 980. Corresponding blood parameter algorithms 970 generate blood parameter outputs 972, such as oxygen saturation (SpO₂), to a data channel 990.

[0053] Also shown in FIG. 9, an acoustic portion has an A/D converter 910, a decimation filter and mixer 920, a coder/compressor 930 and a decoder/decompressor 935 so as to generate acoustic data to the DSP 980. The A/D 910, decimation filter/mixer 920 and a D/A converter 925 are responsive to an acoustic sensor 901 so as to generate an analog “raw” audio 909 output. In an

embodiment, the A/D 910 is a 48Khz, 16-bit, 2-channel variable gain device that provides higher resolution at lower signal amplitudes and lower resolution and higher signal amplitudes. In an embodiment, the decimation filter/mixer generates 2KHz, 32-bit (64Kbps) digitized raw audio 922. Advantageously, the raw audio 909 is routed to a proximate amplifier/speaker 122 (FIG. 1). The digitized raw audio 922 is also input to the coder/compressor 930. A 3:1 (approx.) compression generates a 20Kbps compressed (digitized) audio 908 output. The compressed audio 908 is immediately input into a decoder/decompresser 935 for use by acoustic algorithms 940 to generate respiration rate (RR) and breath tag 942 outputs to a data channel 990, as described above, among other acoustic-related parameters. Advantageously, the compression and immediate decompression of the digitized raw audio 922 provides a compressed audio output 908 that can be stored and retrieved for accurate off-line reproduction and troubleshooting of device behavior. Also, the compressed audio output 908 can be advantageously transmitted via Wi-Fi or other communication links to remote locations for processing and patient analysis.

[0054] FIGS. 10A-B illustrate a “respiration beep” embodiment 1001 for communicating reduced-rate respiration data over relatively low bandwidth monitor data channels and patient networks. As shown in **FIG. 10A**, in some situations, acoustic respiration data 1000 presents an inspiration (I) 1010 pulse relatively closely followed by an expiration (E) 1020 pulse, where each I/E pair is separated by a relatively longer pulseless interval. That is, these I/E pairs are relatively easily distinguished. As such, I/E pairs can be transmitted as simply time-of-occurrence values.

[0055] As shown in **FIG. 10B**, at an inspiration time 1062, a high (HI) frequency tone 1064 is generated. At an expiration time 1062, a low (LO) frequency tone 1064 is generated. A mixer 1050 combines colored noise 1042 with the HI/LO tones 1064 to generate higher-pitched followed by lower-pitched noise pulses representative of the original acoustic waveform 1000. These respiration “beeps” are roughly analogous to pulse oximeter-generated “beeps” that coincide with optical sensor detected arterial blood pulses. In an advantageous embodiment, a processor board 900 (FIG. 9) having optical and acoustic sensors generates simultaneously occurring

respiration beeps and pulse beeps, where the pulse beep tone is easily distinguished from the respiration beep HI/LO noise pulses. These combined pulse/respiration beeps advantageously allow a care provider to “monitor” a patient’s respiration and pulse by sound alone.

[0056] FIG. 11 illustrates a wireless physiological acoustic monitor 1100 embodiment, which is particular advantageous for out-patient applications, such as sudden infant death syndrome (SIDS) prevention and elder care. The monitor 1100 has a sensor section 1101 and a remote section 1102. The sensor section 1101 has a sensor 1110, a sensor interface 1120 and a communications element 1130. In an embodiment, the sensor 1110 is an adhesive substrate integrated with a piezoelectric assembly and interconnect cable, such as described with respect to FIGS. 3A-B, above. The sensor interface 1120 provides power to and receives the sensor signal from the sensor piezo circuit, as described with respect to FIG. 4, above. The wireless communications element 1130 receives the sensor signal from the sensor interface 1120 and transmits the signal to the corresponding communications element 1140 in the remote section 1102, which provides an amplified sensor signal sufficient to drive a small speaker. In an embodiment, the communications link 1160 conforms with IEEE 802.15 (Bluetooth).

[0057] A physiological acoustic monitoring system has been disclosed in detail in connection with various embodiments. These embodiments are disclosed by way of examples only and are not to limit the scope of the claims that follow. One of ordinary skill in art will appreciate many variations and modifications.

WHAT IS CLAIMED IS:

1. An acoustic monitoring system inputs an acoustic sensor signal responsive to tracheal sounds of a person and generates breath tags and a respiration rate, the breath tags representing the acoustic envelope of the tracheal sounds and the respiration rate representing the inverse period of the acoustic envelope, the breath tags and respiration rate having a sufficiently low bandwidth to share a data channel with other physiological parameters, the acoustic monitor comprising:

an acoustic sensor input;

an A/D converter that digitizes the sensor input and outputs a digitized sensor signal;

a decimation filter and mixer that reduces the data rate of the digitized sensor signal and outputs a digitized raw audio; and

an acoustic parameter processor that generates a respiration rate and breath tags in response to the digitized raw audio.

2. The acoustic monitoring system according to claim 1 further comprising a coder/compressor that compresses the digitized raw audio to generate compressed audio data, the compressed audio data is stored and retrieved so as to generate respiration-related parameters in non-real-time.

3. The acoustic monitoring system according to claim 2 further comprising a decoder/decompressor that decompresses the compressed audio data for the acoustic parameter processor.

4. The acoustic monitoring system according to claim 3 further comprising a D/A converter that inputs the digitized raw audio and generates a raw audio analog signal for local playback and listening to the acoustic sensor signal.

5. The acoustic monitoring system according to claim 4 further comprising a transmission of the compressed audio to a remote location as a troubleshooting aid at a remote monitor.

6. An acoustic monitoring method comprising:
inputting a sensor signal responsive to respiratory sounds of a living being;
digitizing the sensor signal so as to generate acoustic data;
extracting an envelope from the acoustic data;
defining an idealized envelope from the extracted envelope;
describing the idealized envelope as a plurality of breath tags; and
transmitting the breath tags over a data channel.

7. The acoustic monitoring method according to claim 6 further comprising:
receiving the breath tags from the data channel;
synthesizing a reconstructed envelope in response to the breath tags; and
generating reconstructed acoustic data by filling the envelope with an artificial waveform.

8. The acoustic monitoring method according to claim 7 wherein the artificial waveform is white noise.

9. The acoustic monitoring method according to claim 8 further comprising:
detecting a physiological feature in the extracted envelope; and
including the physiological feature in the breath tags.

10. The acoustic monitoring method according to claim 9 wherein the synthesizing further comprises modifying the reconstructed envelope with the detected physiological feature.

11. The acoustic monitoring method according to claim 10 wherein the physiological feature is at least one of wheezing and coughing.

12. The acoustic monitoring method according to claim 11 further comprising approximately reproducing the respiratory sounds by playing the reconstructed acoustic data on an audio transducer.

13. An acoustic monitor comprising:
a sensor signal responsive to respiratory sounds of a living being;
an A/D converter that digitizes the sensor signal into acoustic data; and
a parameter generator that extracts a respiratory sound envelope from the acoustic data so as to generate a breath tag,
the breath tag transmitted over a data channel as a representation of the respiratory sounds.

14. The acoustic monitor according to claim 13 further comprising a remote monitoring station that receives the breath tag and a corresponding respiration rate, the monitoring station synthesizing an envelope from the breath tag and the respiration rate and filling the envelope with an artificial waveform so as to generate reconstituted respiratory sounds.

15. The acoustic monitoring method according to claim 14 wherein the artificial waveform is white noise.

16. The acoustic monitor according to claim 15 further comprising:
a decimation filter and mixer that down-samples the acoustic data to raw audio data;
a D/A converter that converts the raw audio data to a raw audio signal; and
a speaker that plays the raw audio signal.

17. The acoustic monitor according to claim 16 further wherein the parameter generator detects a physiological feature in the extracted envelope and includes the physiological feature in the breath tag.

18. The acoustic monitor according to claim 17 wherein the remote monitor modifies the reconstructed envelope with the detected physiological feature.

19. The acoustic monitor according to claim 18 further comprising an audio transducer that approximately reproduces the reconstructed acoustic data as compared to the raw audio signal.

20. The acoustic monitor according to claim 19 further comprising a compressor that generates compressed audio data, the compressed audio data stored and retrieved so as to generate respiration-related parameters in non-real-time.

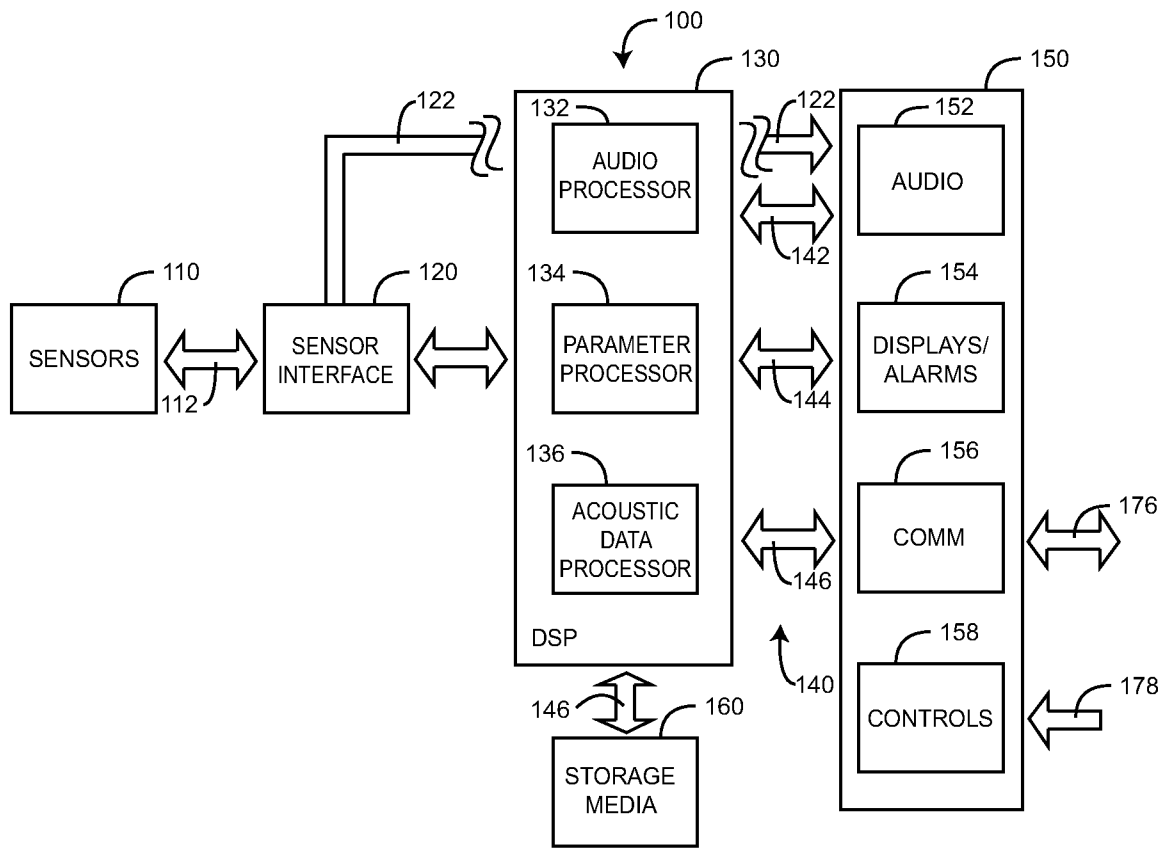

FIG. 1

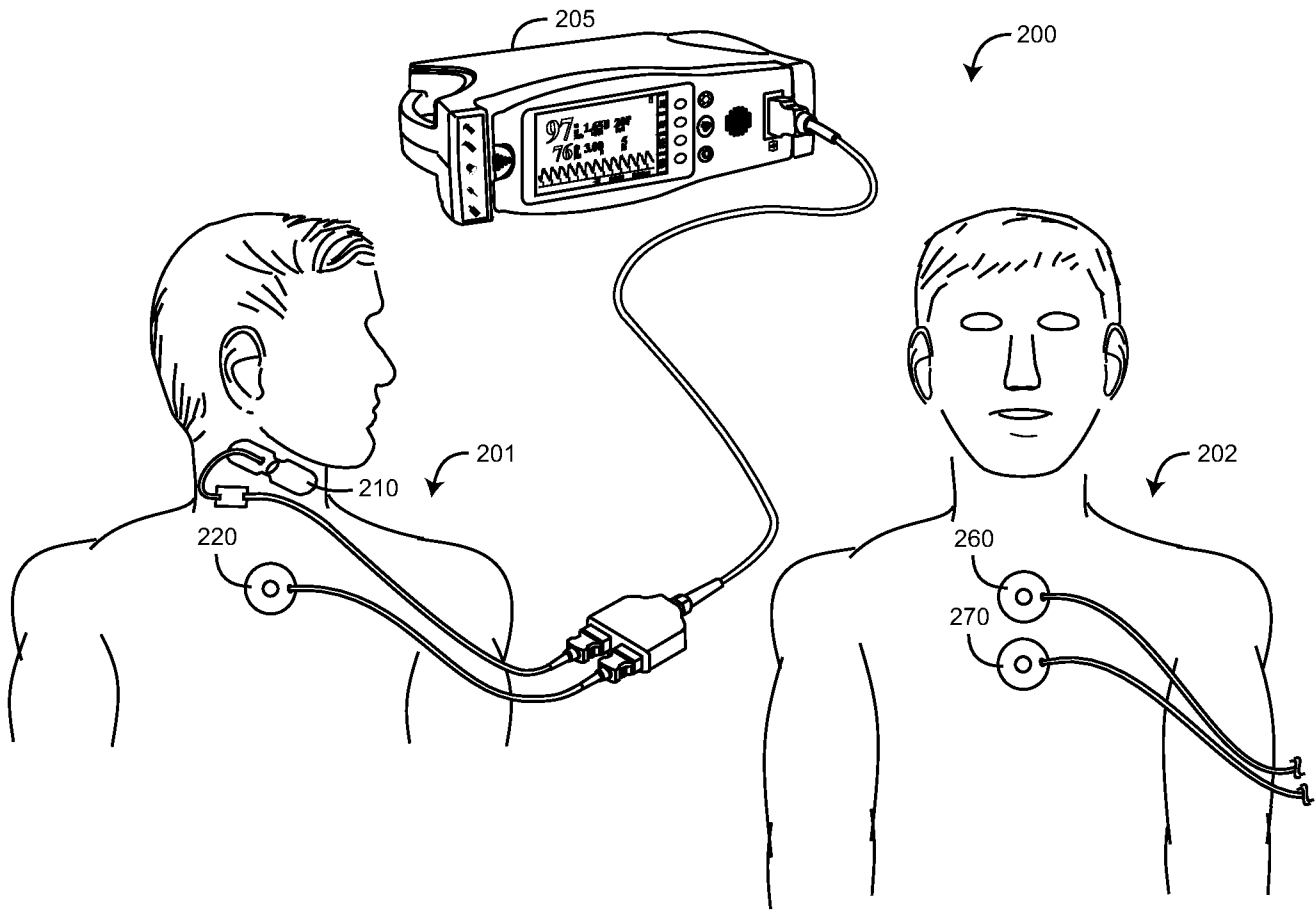

FIG. 2A

FIG. 2B

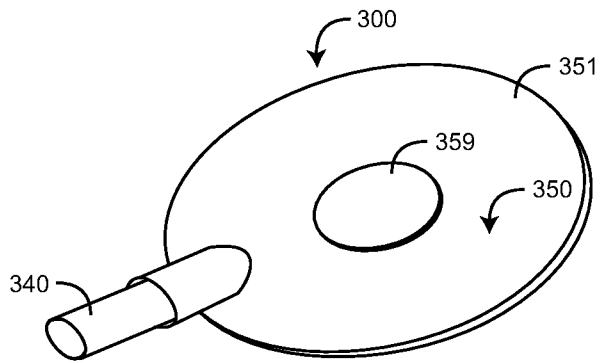

FIG. 3A

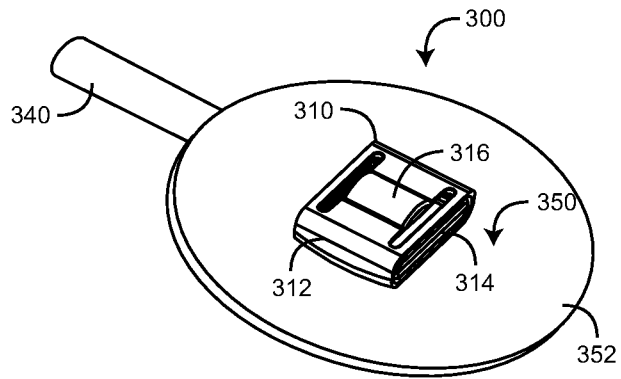

FIG. 3B

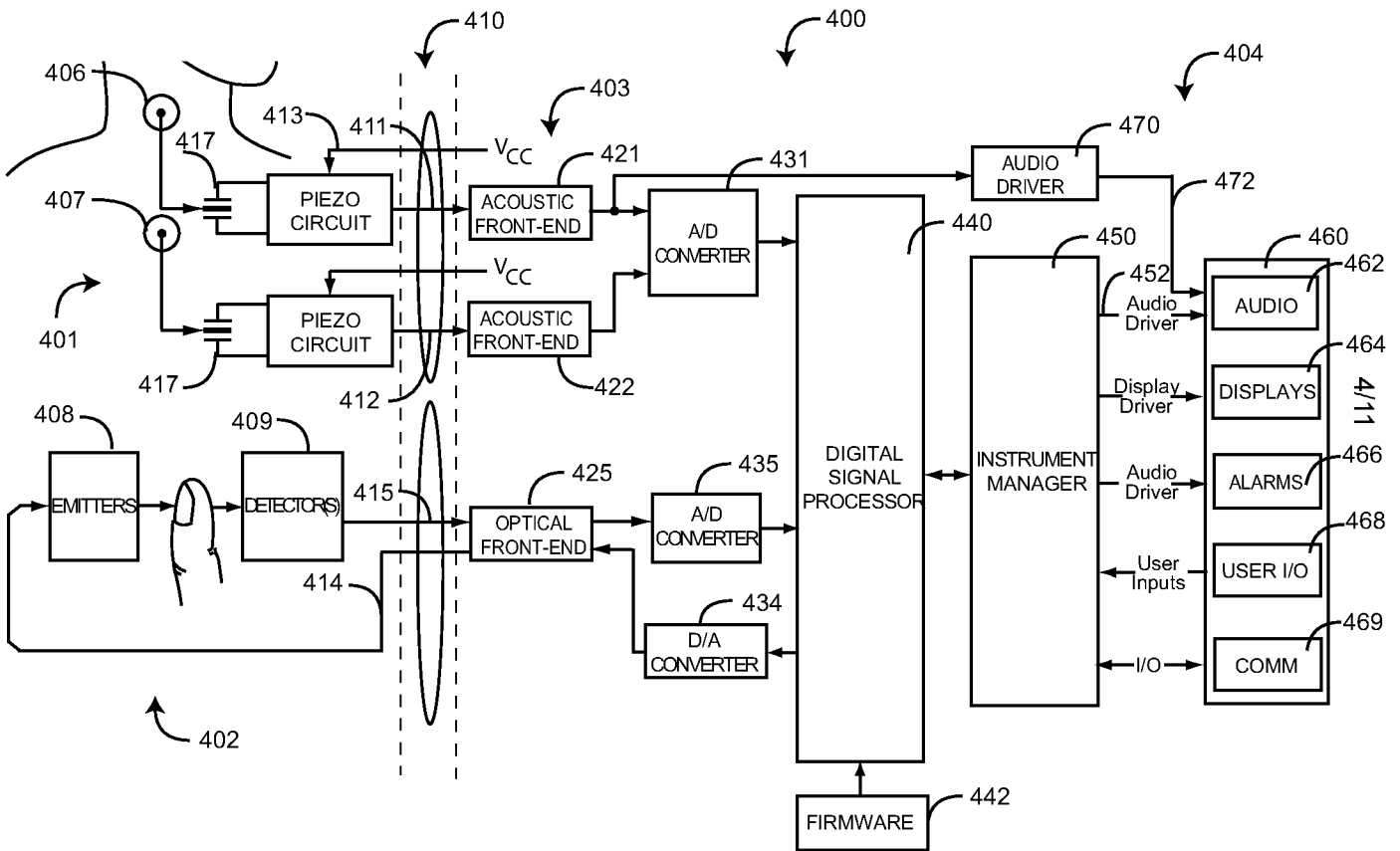

FIG. 4

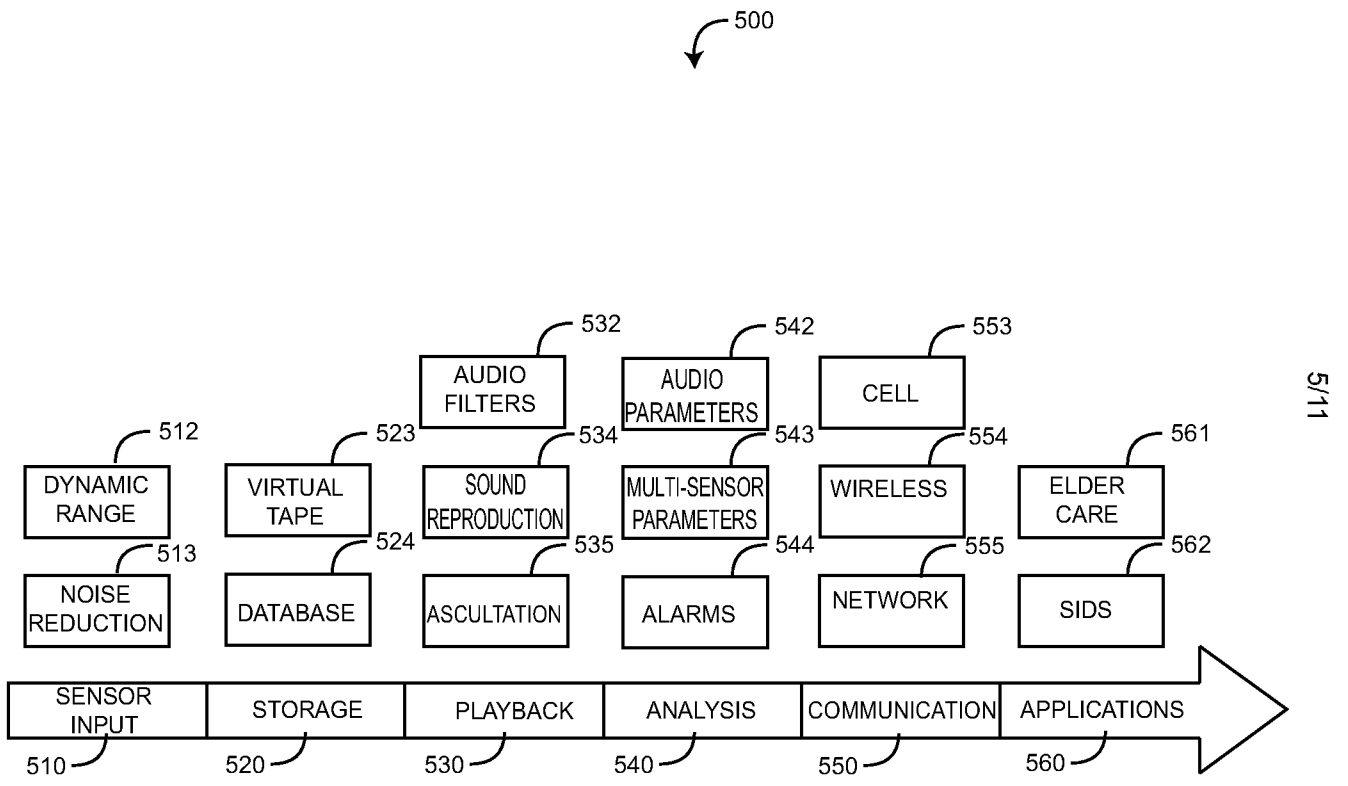

FIG. 5

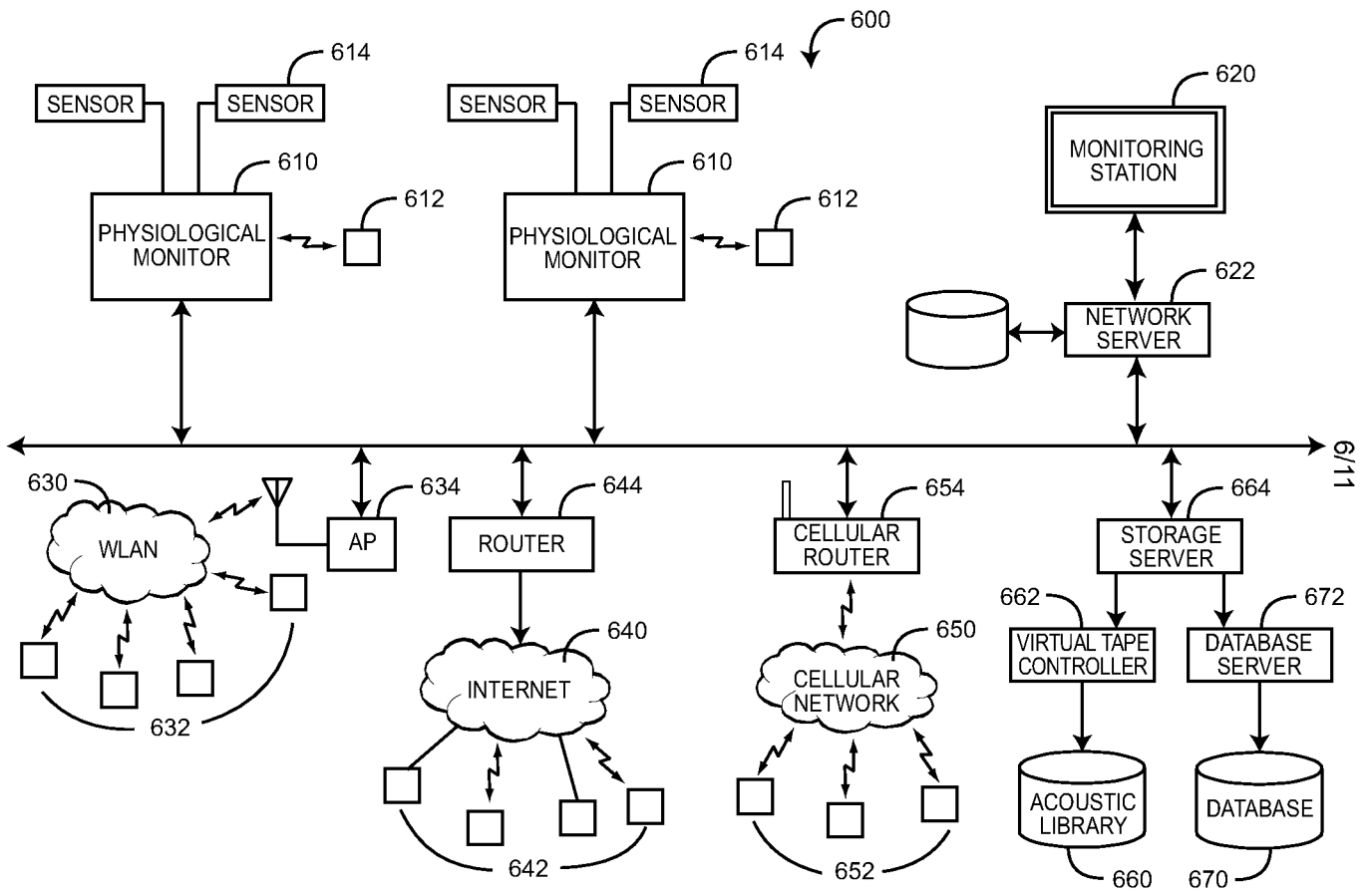
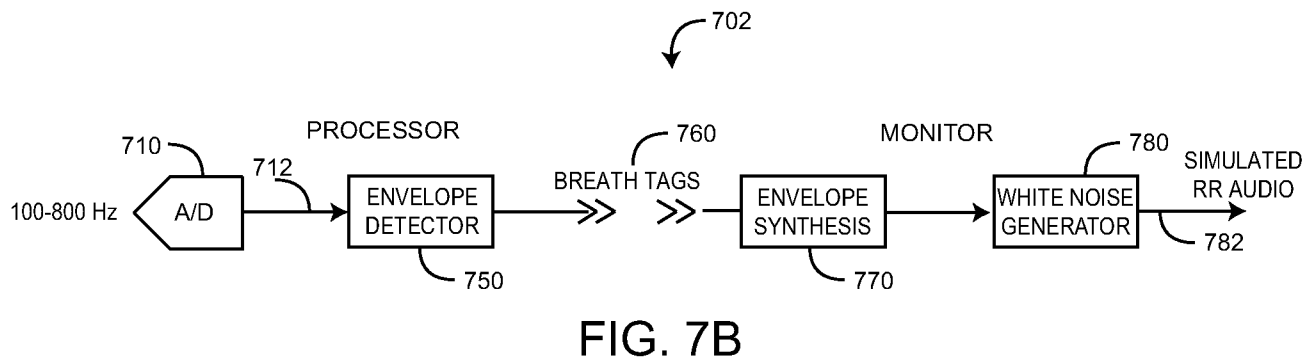
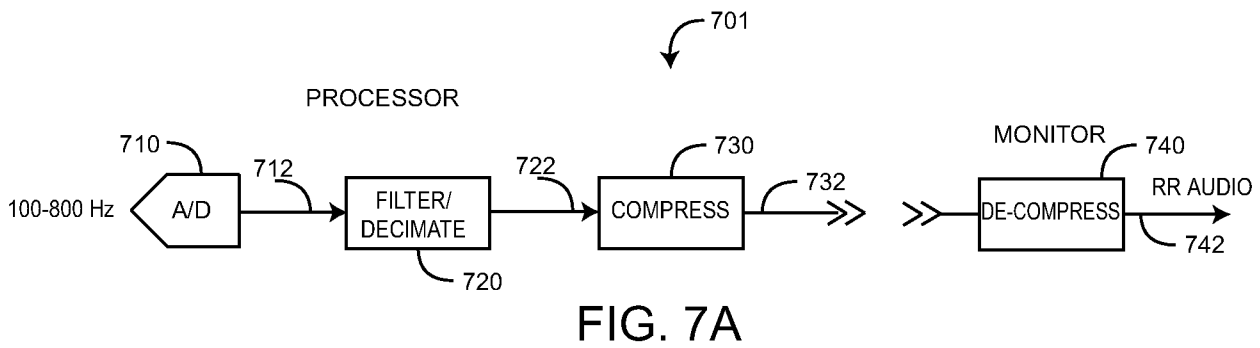
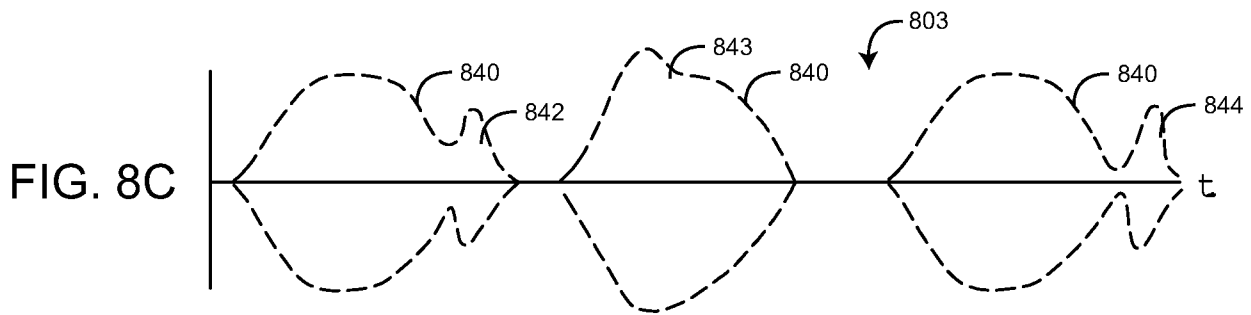
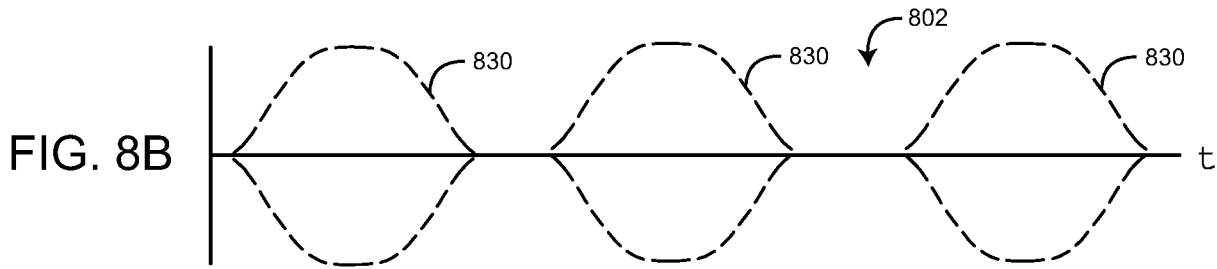
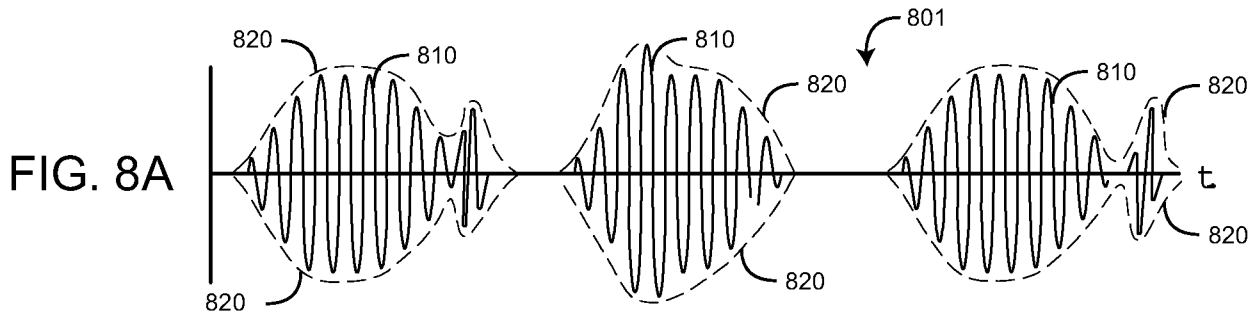

FIG. 6





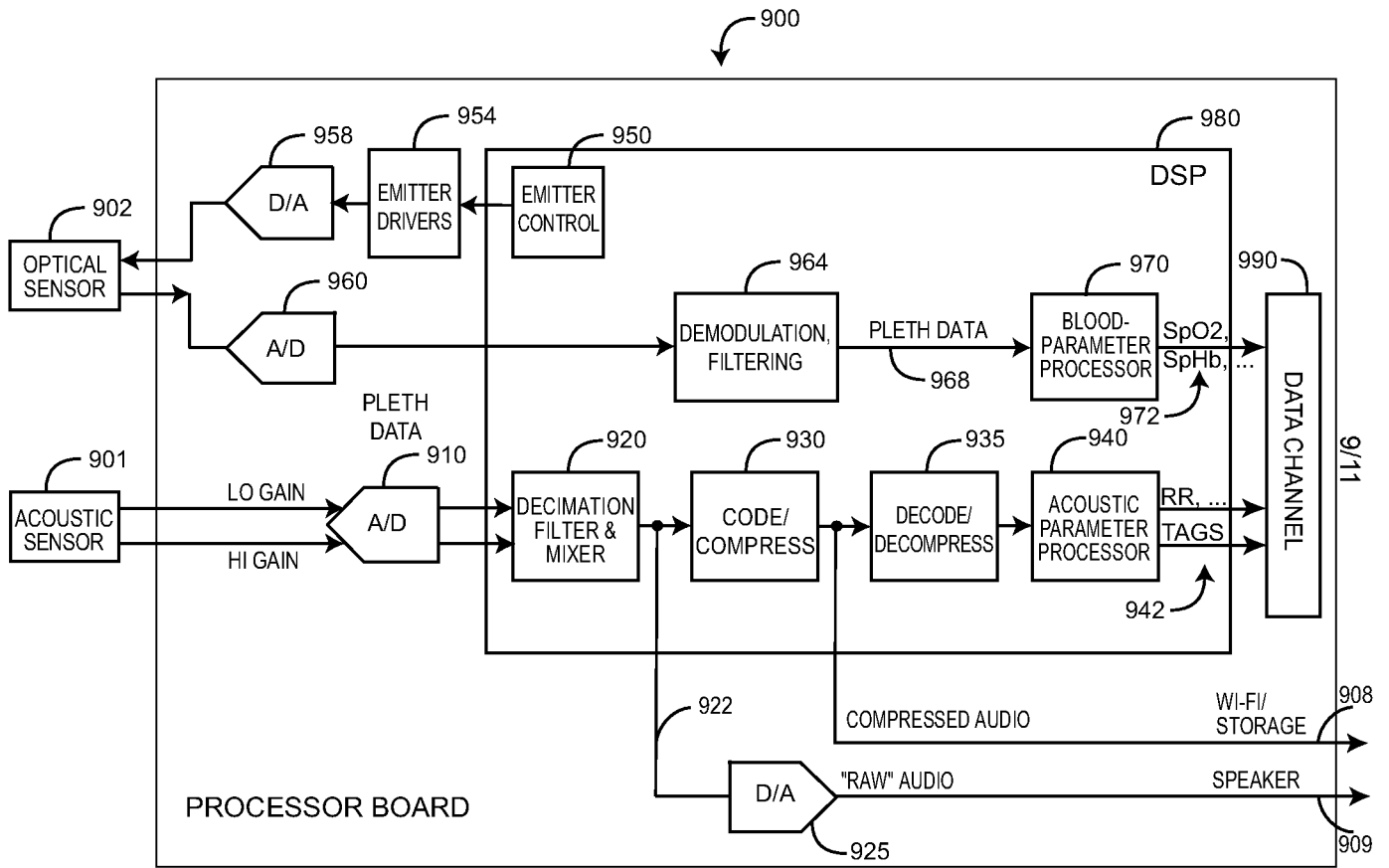

FIG. 9

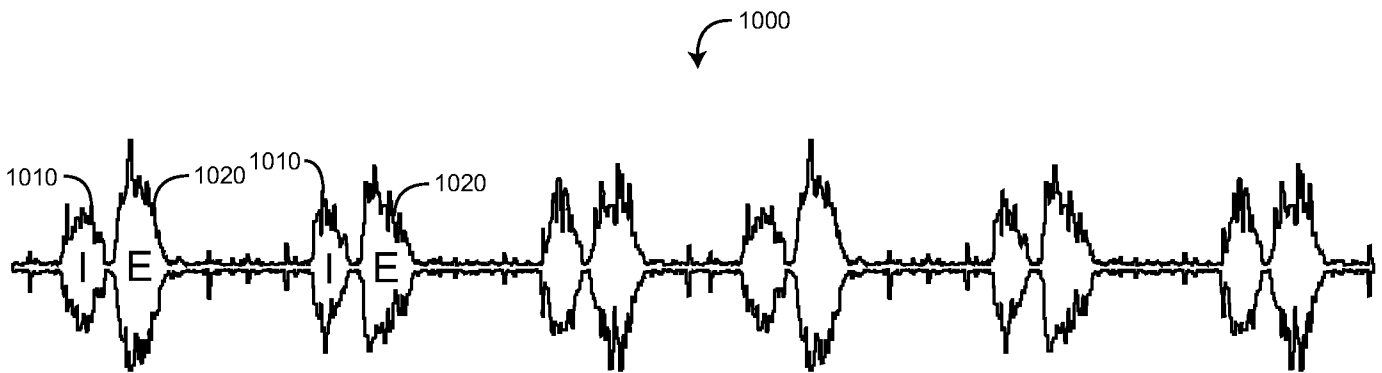

FIG. 10A

10/11

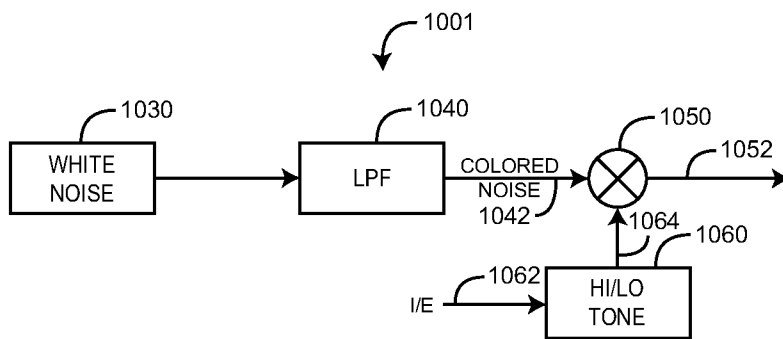

FIG. 10B

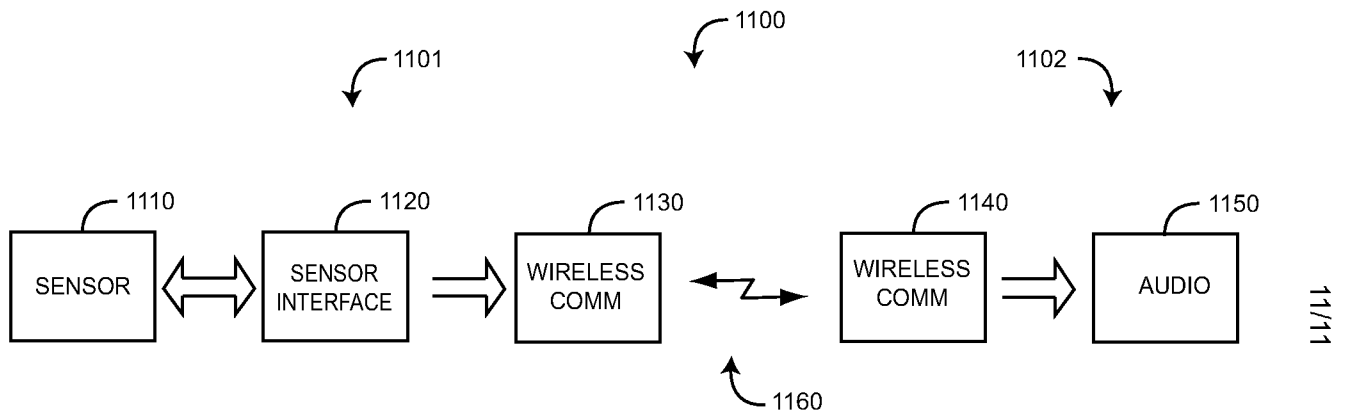

FIG. 11

INTERNATIONAL SEARCH REPORT

International application No
PCT/US2012/060084

A. CLASSIFICATION OF SUBJECT MATTER
 INV. A61B5/08 A61B7/00 A61B7/04 G10L19/00
 ADD.
 According to International Patent Classification (IPC) or to both national classification and IPC

B. FIELDS SEARCHED
 Minimum documentation searched (classification system followed by classification symbols)
 A61B G10L
 Documentation searched other than minimum documentation to the extent that such documents are included in the fields searched

Electronic data base consulted during the international search (name of data base and, where practicable, search terms used)
 EPO-Internal

C. DOCUMENTS CONSIDERED TO BE RELEVANT		
Category*	Citation of document, with indication, where appropriate, of the relevant passages	Relevant to claim No.
X	US 5 143 078 A (MATHER BRUCE C [US] ET AL) 1 September 1992 (1992-09-01) abstract figures 1-5 column 2, line 5 - column 2, line 34 column 2, line 59 - column 5, line 3 -----	1-5
X A	US 2011/172561 A1 (KIANI MASSI JOE E [US] ET AL) 14 July 2011 (2011-07-14) abstract figures 7A,7B,8A,8B,8C paragraph [0048] - paragraph [0051] -----	6-20 2-5
A	US 2007/282212 A1 (SIERRA GILBERTO [CA] ET AL) 6 December 2007 (2007-12-06) abstract figures 1-8 paragraph [0031] - paragraph [0077] -----	1-20

Further documents are listed in the continuation of Box C.

See patent family annex.

* Special categories of cited documents :

- "A" document defining the general state of the art which is not considered to be of particular relevance
- "E" earlier application or patent but published on or after the international filing date
- "L" document which may throw doubts on priority claim(s) or which is cited to establish the publication date of another citation or other special reason (as specified)
- "O" document referring to an oral disclosure, use, exhibition or other means
- "P" document published prior to the international filing date but later than the priority date claimed

- "T" later document published after the international filing date or priority date and not in conflict with the application but cited to understand the principle or theory underlying the invention
- "X" document of particular relevance; the claimed invention cannot be considered novel or cannot be considered to involve an inventive step when the document is taken alone
- "Y" document of particular relevance; the claimed invention cannot be considered to involve an inventive step when the document is combined with one or more other such documents, such combination being obvious to a person skilled in the art
- "&" document member of the same patent family

Date of the actual completion of the international search

14 December 2012

Date of mailing of the international search report

21/12/2012

Name and mailing address of the ISA/
 European Patent Office, P.B. 5818 Patentlaan 2
 NL - 2280 HV Rijswijk
 Tel. (+31-70) 340-2040,
 Fax: (+31-70) 340-3016

Authorized officer

Moehrs, Sascha

INTERNATIONAL SEARCH REPORT

Information on patent family members

International application No PCT/US2012/060084

Patent document cited in search report	Publication date	Patent family member(s)	Publication date
US 5143078	A	01-09-1992	NONE
US 2011172561	A1	14-07-2011	US 2011125060 A1 26-05-2011
			US 2011172561 A1 14-07-2011
US 2007282212	A1	06-12-2007	CA 2464029 A1 08-10-2005
			CA 2562258 A1 20-10-2005
			EP 1740095 A1 10-01-2007
			JP 2007532156 A 15-11-2007
			US 2007282212 A1 06-12-2007
			WO 2005096931 A1 20-10-2005