

No. 817,455.

PATENTED APR. 10, 1906.

W. H. TAYLOR.  
LATCH.

APPLICATION FILED APR. 6, 1906.

2 SHEETS—SHEET 1.

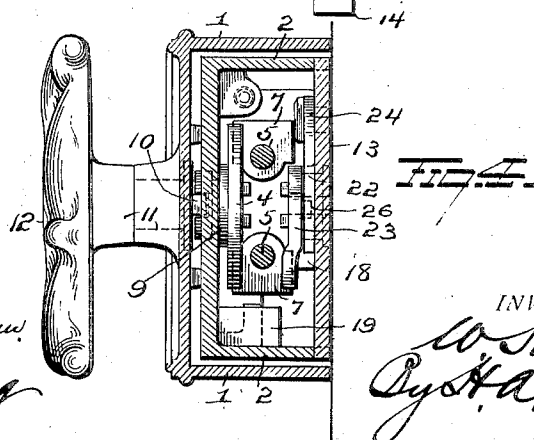
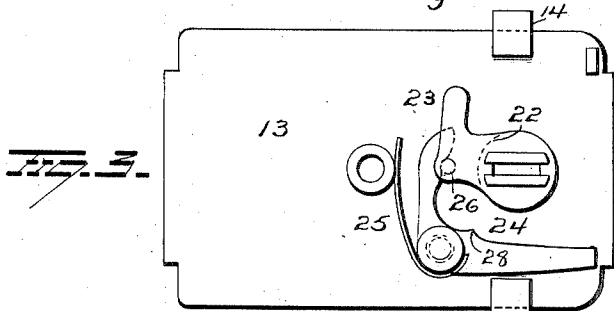
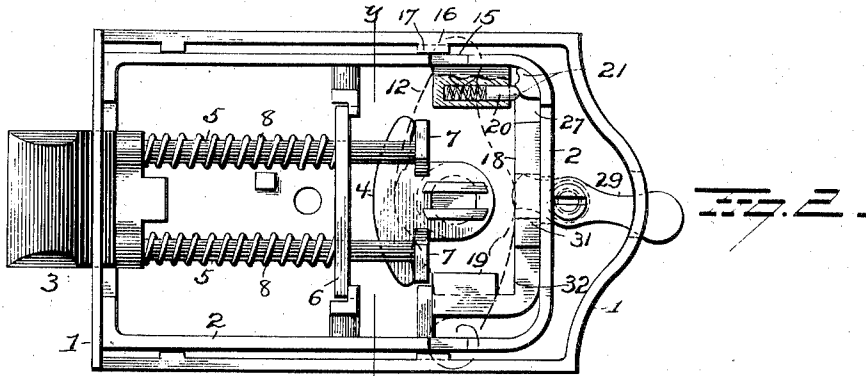
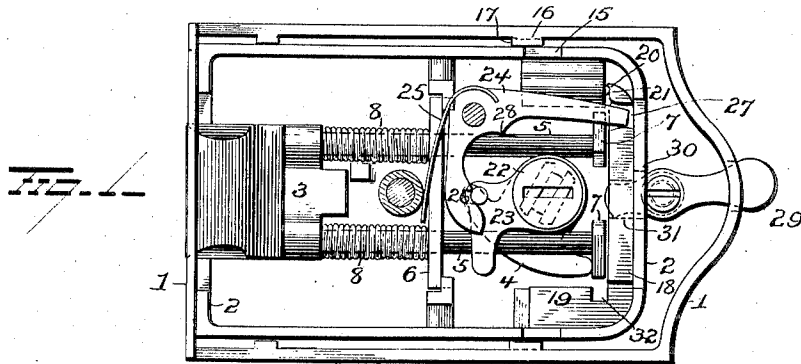

WITNESSES  
*E. Nottingham*  
*G. F. Downing*

INVENTOR  
*W. H. Taylor*  
*Cy. H. Seymour*  
Attorney

No. 817,455.

PATENTED APR. 10, 1906.

W. H. TAYLOR.  
LATCH.

APPLICATION FILED APR. 6, 1905.

2 SHEETS—SHEET 2.

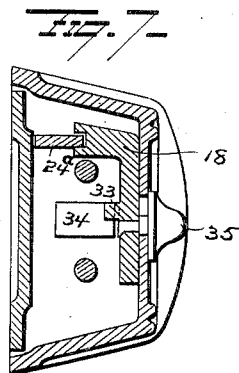
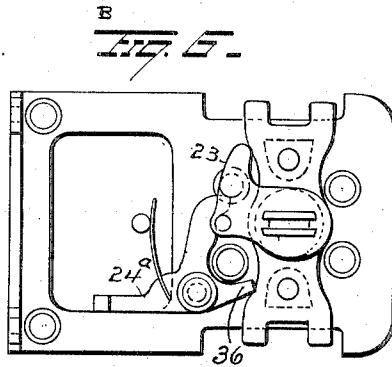
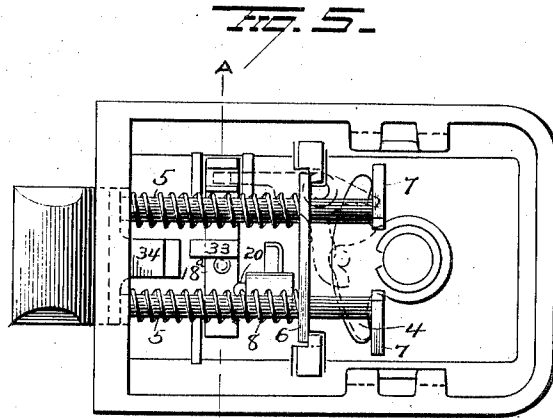

WITNESSES  
*E. Nottingham*  
*G. J. Downing*

INVENTOR  
*W. H. Taylor*  
*Cy. A. Seymour*  
Attorney

# UNITED STATES PATENT OFFICE.

WARREN H. TAYLOR, OF STAMFORD, CONNECTICUT, ASSIGNOR TO THE YALE & TOWNE MANUFACTURING COMPANY, OF STAMFORD, CONNECTICUT.

## LATCH.

No. 817,455.

Specification of Letters Patent.

Patented April 10, 1906.

Application filed April 6, 1905. Serial No. 254,198.

To all whom it may concern:

Be it known that I, WARREN H. TAYLOR, of Stamford, in the county of Fairfield and State of Connecticut, have invented certain new and useful Improvements in Latches; and I do hereby declare the following to be a full, clear, and exact description of the invention, such as will enable others skilled in the art to which it appertains to make and use the same.

My invention relates to an improvement in latches, the object of the invention being to provide means whereby the latch may be deadlocked either from the inside or through the escutcheon on the outside of the door, the construction and arrangement being such that when the latch is deadlocked from the inside any one in possession of a proper key to the lock can from the outside of the door throw off the deadlock and actuate the latch.

With these ends in view my invention consists in the parts and combinations of parts, as will be more fully described, and pointed out in the claims.

In the accompanying drawings, Figure 1 is a view in elevation of the lock with the rear face removed, showing the deadlocking-slide in its normal position and the latch retracted. Fig. 2 is a similar view showing the slide deadlocking the latch. Fig. 3 is a view of the inner face of the rear plate of the lock-casing, showing the parts carried thereby. Fig. 4 is a view in transverse section through the lock in rear of the cam. Fig. 5 is a plan view of a modified form of latch. Fig. 6 is a view of the inner face of the rear plate of the casing, showing the parts carried thereby; and Fig. 7 is a view in section on the line A B of Fig. 5.

In the construction shown in Figs. 1, 2, 3, and 4 I have shown the improvements applied to a high-grade latch, the locking mechanism being secured within a casing located within an outer ornamented casing, while in Figs. 5, 6, and 7, which represent a cheaper grade of lock, the locking mechanism is secured directly within the outer casing.

In Figs. 1, 2, 3, and 4, 1 represents an outer casing, preferably made of brass, bronze, or other metal, suitably ornamented and provided at its front end with a lip having screw-holes for its attachment to the door. Located within the casing 1 is the casing 2, which carries and contains the locking mech-

anism. This locking mechanism comprises a spring-actuated latch 3, a double cam 4, and means connecting the double cam and latch, whereby a movement of the cam in either direction operates to retract the latch. The mechanism connecting the latch 3 and double cam 4 comprises two rods 5, each secured at one end to the latch, passing rearwardly through a cross-bar 6, and provided at their free ends with wings 7, each of which rests in rear of one member of the cam 4, so that a turning movement of the cam in either direction operates, through a wing 7 and its rod 5, to retract the latch, the latter being held in its normal position by the spiral springs 8, which encircle the rods 5 in advance of the cross-bar 6. The cam 4 is secured to a disk 9, which is mounted in and passes through the front wall of casing 2 and is provided at its outer end with an oblong slot or groove adapted to receive the projecting lugs 10 on the end of the knob-stem 11, the latter being mounted in the outer casing 1 and provided with a knob or handle 12, by which the cam can be turned. With this construction it will be seen that the mechanism of the latch can be assembled within the inner casing 2, and when the latter is placed within the outer casing it is simply necessary to manipulate the knob or handle 12, if necessary, until the lugs 10 aline with the oblong slot or groove in disk 9. This detachably connects the knob or handle to the locking mechanism for operating the latch from the inside. The rear or removable face-plate 13 of the inner casing 2 is secured to the body of the casing by a screw or screws in the usual manner and is provided with the laterally-projecting lugs 14, which latter enter slots 15 in the sides of inner casing 2 and which when assembled in the outer casing enter slots 16 in the ribs 17, formed on the sides of the outer casing. These lugs engaging the sides of the outer casing, together with the latch passing through the front end of the outer casing, hold the two casings in their assembled positions. Located at the rear end of the casing 2 is the deadlocking-slide 18. This slide is provided at one end with the integral dog 19, which when the slide 18 is moved in one direction is carried into the path of movement of the adjacent wing 7 and absolutely locks the latch against longitudinal movement, and

consequently prevents any rotation of the knob or handle 12, and when moved in the opposite direction is moved out of the path of said wing and permits of free rearward movement of the latch by the knob or handle 12. The deadlocking-slide 18 is retained against accidental movement by the spring-pressed pin 20, seated in a socket and bearing at its end in grooves 21, a groove being provided for each extreme movement of the slide. Secured to and mounted in the removable plate 13 of the inner casing 2 is the disk 22, which latter carries at its inner end the single cam 23, adapted to engage one wing 7 of the latch mechanism, so that when turned in one direction it operates to retract the latch. This disk 22 is connected in the usual manner by a connecting-bar with suitable tumbler or locking mechanism of any preferred kind in the escutcheon, which extends to the outside of the door. Consequently by introducing the proper key into the escutcheon and turning the key the cam 23, engaging one wing 7 of the locking mechanism, retracts the bolt. Pivotaly secured to the inner face of the removable plate 13 is the bell-crank lever 24. This lever is provided with a spring 25, which tends to hold the transverse member of the bell-crank in contact with a pin 26 on the cam 23. The longer or horizontal member of this lever 24 rests in a slot 27 in the deadlocking-slide 18. Hence when the lever 24 is moved the slide moves with it, and when the slide is moved by mechanism on the inside of the door the lever is necessarily turned on its pivot. The free end of the transverse member of the lever 24 is in the form of a cam, which is designed to be engaged by the pin 26 on the cam 23 during the turning movements of the latter, and thus rock the bell-crank on its pivot. If the deadlocking-slide 18 be set to dog the latch, this turning movement of the cam 23 rocks the lever 24 sufficiently to shift the slide to a position out of the path of movement of the wing 7, thus permitting the latch to be withdrawn. After the slide has been thrown to a position to permit the bolt to be retracted it will be so held by the spring-actuated pin 20. When it is desired to deadlock the door from the outside, the key should be inserted and turned in a direction opposite to that in which it is turned to withdraw the latch. This causes pin 26 on the cam 23 to bear against the shoulder 28 on the long or horizontal member of the bell-crank lever 24, thus overcoming the friction of the pin 20 and permitting the spring 25 to move the slide 18 back to its deadlocking position. The latch can be deadlocked from the inside by the lever 29, pivoted to the outer case 1, passing through slot 30 in the inner casing 2 and resting at its inner end in a slot or seat 31 in the deadlocking-slide. By means of the lever 29 the latch can when retracted by the

knob 12 be held in such position by moving the deadlocking-slide to its deadlocking position, thus causing the wing 7 to enter slot 32 in the slide 18 and be held there until the slide be again moved either by the lever 29 on the inside or, as previously explained, by the key on the outside.

In the constructions previously described the deadlocking-slide is constructed and arranged to engage the wing 7 on the rod 5. In the construction shown in Figs. 5, 6, and 7 this slide is located between the latch-actuating mechanism and the bolt and is designed to directly engage the tongue 34 on the rear or inner end of the latch-bolt. This tongue terminates near the front edge of the case and directly in front of the slide 18<sup>a</sup>, as clearly shown in Fig. 5. This slide 18<sup>a</sup> is provided with a stop 33, which may be moved by the bell-crank lever 24<sup>a</sup> and cam 23 or by the knob 35 into or out of the path of movement of the tongue, and thus deadlock or release the latch-bolt, as the case may be. In this modification, as in the main construction, the latch may be operated from the inside by a double cam connected to the knob-spindle, as shown in Fig. 5, and by a single cam 23, (shown in Fig. 6,) operated by a key from the outside. As in the previous construction, this single cam is carried on the removable plate of the casing and when turned in one direction actuates the latch-bolt, and when turned in the opposite direction the pin therein engages the tail 36 of the bell-crank lever and shifts the slide to a position to deadlock the latch, the slide being retained against accidental movement by the spring-actuated pin 20 engaging notches in the slide, as shown in Fig. 5.

With these constructions it is apparent that the latch can be deadlocked from the inside or through the escutcheon on the outside of the door, the mechanism being such that when any one on the inside deadlocks the latch any one in possession of the proper key can move the deadlocking-slide out of the path of the bolt and throw back the latch.

It is evident that many slight changes might be resorted to in the relative arrangement of parts shown and described without departing from the spirit and scope of my invention. Hence I would have it understood that I do not wish to confine myself to the exact construction of parts shown and described; but,

Having fully described my invention, what I claim as new, and desire to secure by Letters Patent, is—

1. In a latch the combination with a bolt, means for deadlocking the bolt in its outward position, means on the inside of the door whereby said deadlocking means may be shifted to its operative or inoperative positions, and yielding means for retaining said deadlocking means in either of said positions,

of key-actuated mechanism which when turned in one direction first shifts the deadlocking mechanism to its inoperative position and retracts the bolt.

5 2. In a latch, the combination with a casing, and a spring-actuated latch, of means for connecting the latching mechanism with a knob or handle, key-actuated means for actuating the latch, a deadlocking-slide and  
10 means operated by the key mechanism of the latch for moving the slide out of the path of the latch, and also for positively moving said slide in a position to deadlock the latch, substantially as set forth.

15 3. In a latch, the combination with a casing and a spring-actuated latch, of a knob for actuating the latch, key-actuated mechanism for actuating the latch, a deadlocking-slide, means for setting the slide to deadlock  
20 the latch, and means actuated by the key mechanism for moving the slide out of the path of the latch, and for returning the slide to its deadlocking position.

4. The combination with a casing and a  
25 spring-latch therein, of a deadlocking-slide, means on the inner side of the latch-casing for throwing the slide, and key-actuated mechanism for throwing off the deadlock from the outside of the door for retracting the latch  
30 and for positively deadlocking the latch.

5. The combination with a casing and a  
35 spring-latch, of a deadlocking-slide for the latter and key mechanism for moving the slide out of the path of the latch, for retracting the latch and for resetting the deadlocking mechanism.

6. The combination with a casing and a  
40 spring-latch, of a deadlocking-slide, means on the inner side of the casing for shifting the slide, and mechanism actuated from the outside of the door for moving the slide out of the

path of the latch for retracting the latch and for resetting the deadlocking mechanism.

7. The combination with a casing and a  
45 spring-latch, of a deadlocking-slide for the latter, a key-actuated cam for retracting the latch, and means actuated by said cam for moving the slide out of the path of the latch.

8. The combination with a casing and a  
50 spring-latch, of a deadlocking-slide, means projecting from the inner side of said casing for moving the slide, a key-actuated cam for retracting the latch and a lever actuated by said cam and engaging the slide for moving the latter out of the path of the latch. 55

9. The combination with a casing and a  
60 spring-latch, of a deadlocking-slide, a cam for retracting the latch and means actuated by said cam for moving the slide out of the path of the latter, and for resetting the slide after the latch has been released.

10. The combination with a casing and a  
65 spring-latch, of a deadlocking-slide, a cam for retracting the latch and a lever actuated by said cam and engaging the slide for moving it out of the path of the latch and for returning it to a position to deadlock the latch after the latch has been released.

11. The combination with a casing and a  
70 spring-latch, of a deadlocking-slide, means for holding the latter against accidental movement, a cam for retracting the latch and a lever actuated by the cam and engaging the slide for moving the latter out of the path of the latch. 75

In testimony whereof I have signed this specification in the presence of two subscribing witnesses.

WARREN H. TAYLOR.

Witnesses:

SCHUYLER MERRITT,  
PATRICK KIEFF.