

H. HYLANDER.
FLOATING DOCK.

APPLICATION FILED MAR. 10, 1903.

NO MODEL.

3 SHEETS—SHEET 1.

Fig. 1.

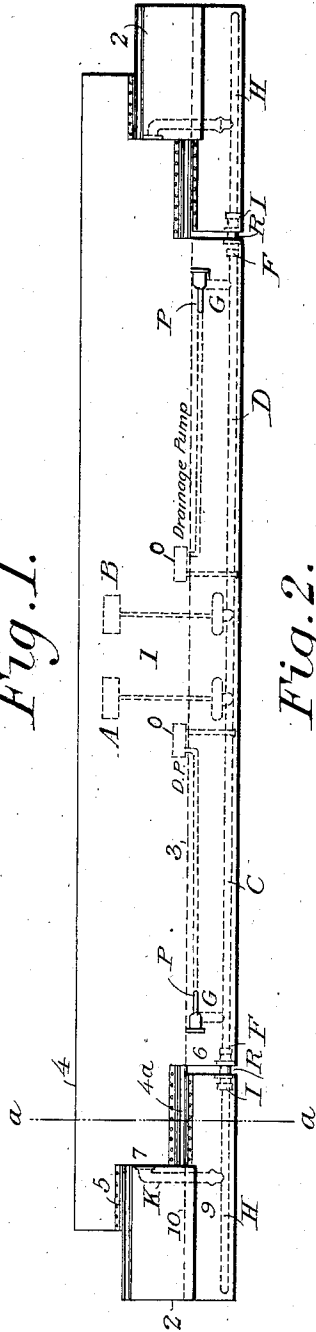

Fig. 2.

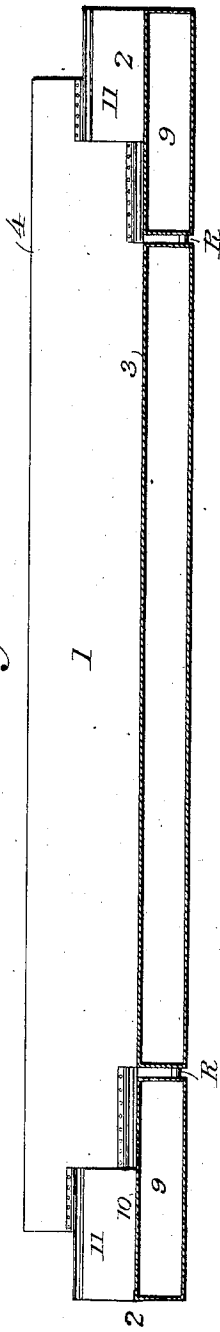

Fig. 4.

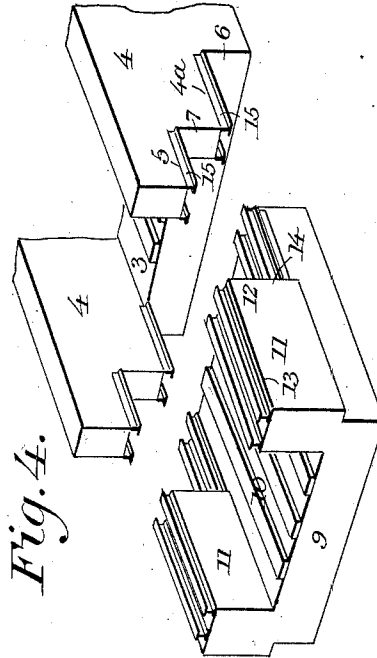
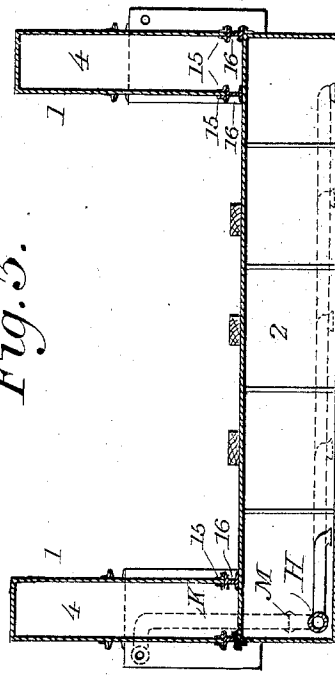

Fig. 5.



WITNESSES:

A. M. E. Kennedy
Geo. M. Copenhagen

INVENTOR

Hjalmar Hylander

BY

P. T. Sodge
ATTORNEY

H. HYLANDER.
FLOATING DOCK.

APPLICATION FILED MAR. 10, 1903.

NO MODEL.

3 SHEETS—SHEET 2.

Fig. 5.

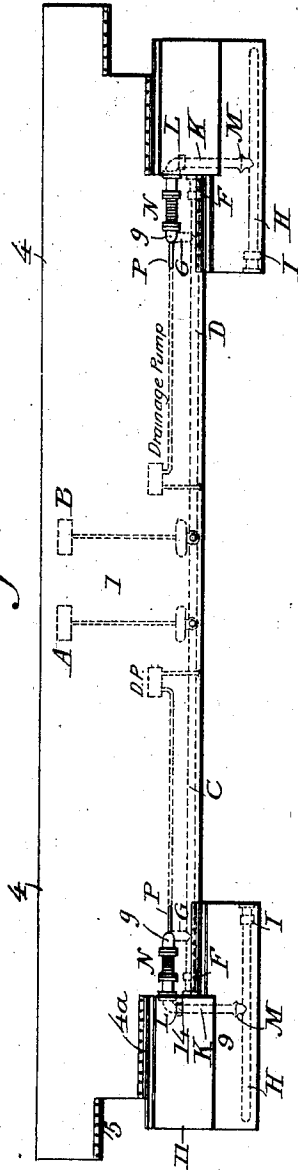
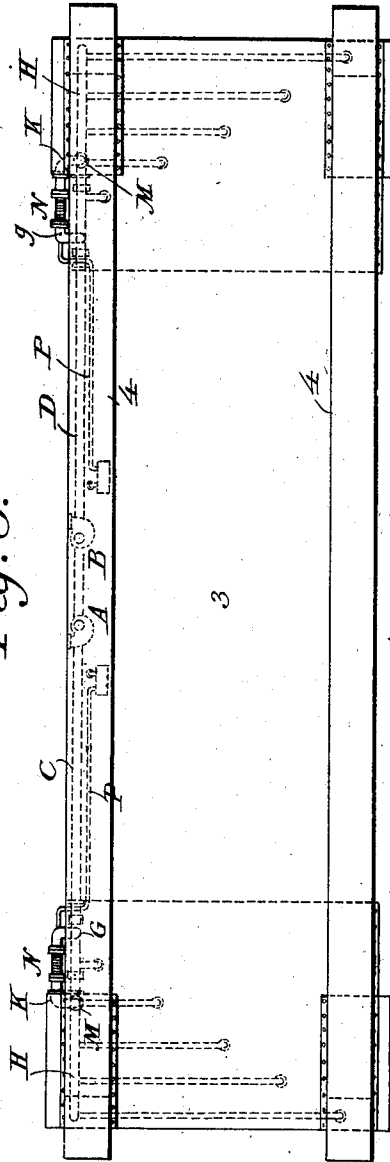

Fig. 6.



WITNESSES:

A. W. Kennedy
Geo. M. Copenhagen

INVENTOR

Hjalmar Hylander

BY

P. T. Soder
 ATTORNEY.

H. HYLANDER.
FLOATING DOCK.

APPLICATION FILED MAR. 10, 1903.

NO MODEL.

3 SHEETS—SHEET 3.

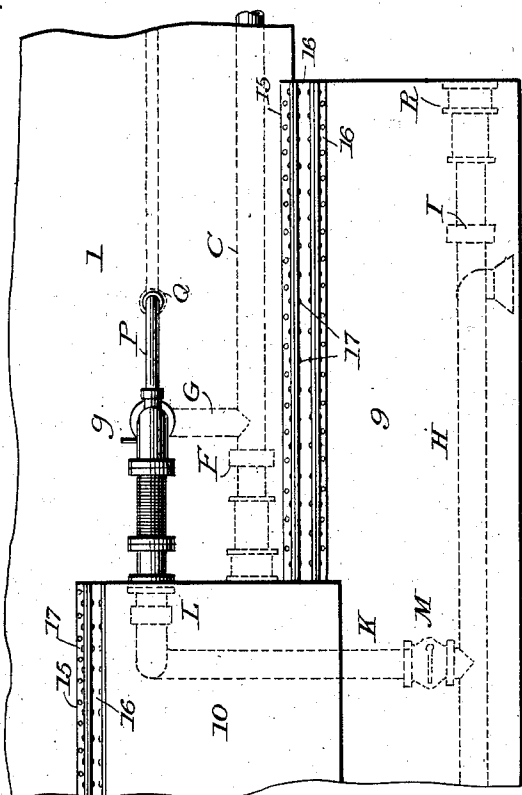

Fig. 8.

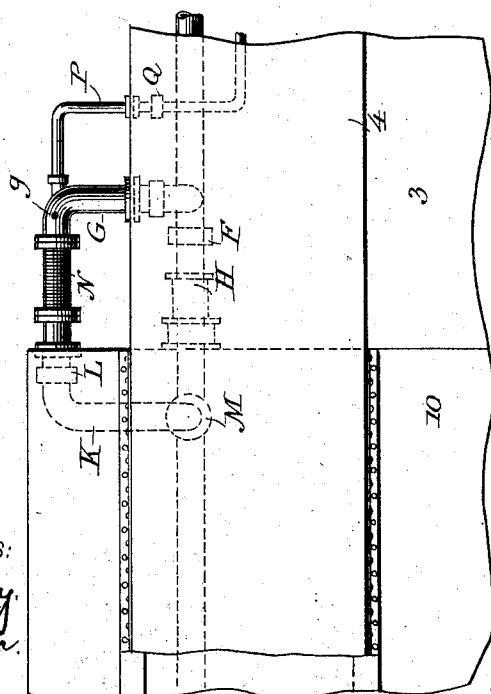

Fig. 7.

WITNESSES:

A. M. E. Kennedy
Geo. M. Coppenhaver

INVENTOR

Hjalmar Hylander
BY
P. F. Dodge
ATTORNEY

UNITED STATES PATENT OFFICE.

HJALMAR HYLANDER, OF BALTIMORE, MARYLAND.

FLOATING DOCK.

SPECIFICATION forming part of Letters Patent No. 736,732, dated August 18, 1903.

Application filed March 10, 1903. Serial No. 147,103. (No model.)

To all whom it may concern:

Be it known that I, HJALMAR HYLANDER, a subject of the King of Sweden and Norway, residing at the city of Baltimore, State of Maryland, have invented a new and useful Improvement in Floating Docks, of which the following is a specification.

This invention relates to floating docks, and has reference more particularly to the type of docks made up of separable sections which are adapted to be connected together to dock vessels and adapted also to be separated, so that the individual sections may themselves be docked.

My invention is embodied in a dock of this general type in which there are three sections, a main, comparatively long central one, and two smaller end ones, the latter being of a size sufficient only to jointly sustain the weight of the larger one, whereby the central section may be of great length in comparison to the length of the dock over all, will present a maximum extent of unbroken supporting-surface, and at the same time may be safely and effectively docked on the end sections.

My invention is directed mainly to the relative construction of the end sections and central one, having in view great stability and buoyancy, both when connected up end to end and when the central pontoon is docked on the end ones; and the invention consists, first, in forming the central pontoon with side walls overhanging the ends of the same and the end pontoons with side walls adapted when the sections are connected end to end to form continuations of the overhanging side walls of the central pontoon and so formed that when the end sections are assembled to dock the central one the side walls of the end sections will extend beneath the overhanging side walls of the central sections; second, in so forming the end pontoons and the ends of the main central section that when assembled in their different relations the end pontoons may be pumped by pumping mechanism on the main pontoon.

The invention further consists in the details of construction and combination of parts hereinafter described and claimed.

In the accompanying drawings, Figure 1 is a side elevation of the dock as it appears with

the sections connected end to end ready for use in docking vessels. Fig. 2 is a longitudinal sectional elevation of the same. Fig. 3 is a transverse section, on an enlarged scale, on the line *aa* of the preceding figures. Fig. 4 is a perspective view of the end of the main section and one of the end pontoons separated. Fig. 5 is a side elevation of the parts of the dock, showing how the main pontoon is dry-docked on the end ones. Fig. 6 is a top plan view of the same. Fig. 7 is a plan view, on an enlarged scale, of the adjacent ends of the end pontoon and the central pontoon, showing the pipe connection by which the end pontoon is pumped by mechanism on the main pontoon. Fig. 8 is a side elevation of the same.

Referring to the drawings, as shown in Fig. 1, the dock comprises three sections or pontoons, a main central one 1 of comparatively great length and two end small pontoons 2, the latter of a size sufficient only to jointly have a lifting capacity when pumped out equal to the weight of the central pontoon, whereby the dock as a whole when the sections are connected end to end will present a central unbroken and uninterrupted supporting-surface of great length in comparison to the length of the dock over all.

The main central pontoon comprises a horizontal chamber having a supporting-flooring 3 and provided with hollow side walls 4, extending upward from the edges of the chamber, which side walls are extended at their ends beyond the ends of the flooring, so as to overhang the same, as clearly shown in Figs. 1 and 3, the overhanging ends of the walls being so formed as to present horizontal stepped surfaces 4^a and 5, one above the other, a vertical surface 7, connecting said horizontal surfaces, and a lower inner vertical surface 6, constituting the end of the horizontal chamber and joining the inner end of the horizontal surface 4^a.

The end pontoons each comprises a horizontal chamber 9, provided with a flooring 10, which constitutes a continuation of the flooring of the central pontoon when the sections are connected end to end, as shown in Fig. 1. From the sides of the chamber 9 rise hollow side walls 11, which are adapted to form continuations of the side walls of the main pon-

toons and which are formed at their inner ends to match or fit in the stepped surfaces of the overhanging ends of the side walls of the main pontoon. This is accomplished by forming the side walls of the end pontoon with their inner ends terminating inward of the inner end of the flooring or chamber 9, so as to form a shoulder 12, which shoulder is formed jointly by the upper surface 13 of the wall and its inner vertical end 14. In other words, the horizontal chamber 9 of the end pontoon extends inward beyond the inner ends of the side walls, so that when the end pontoons are connected with the main pontoon with their floorings on a level with the main pontoon the side walls of the end pontoon will fit beneath the overhanging ends of the side walls of the main pontoon and will form continuations of said side walls, the upper surface 13 of the end walls extending beneath the horizontal surface 5, the vertical end 14 of the side walls abutting against the vertical surfaces 7 and the extended flooring of the end pontoons fitting beneath the horizontal surface 4^a. It is seen, therefore, that in this position of the parts the end pontoons are, in effect, continuations of the main pontoon, both in respect to the flooring and the side walls. By reason of this construction when the main section is dry-docked on the end sections the side walls of the latter extend beneath and form downward continuations of the overhanging ends of the side walls of the main pontoon, as shown in Fig. 5, where it will be seen that the upper surfaces of the walls of the end pontoons extend beneath the horizontal surface 4^a, with the inner ends 14 of said walls abutting against the ends of the horizontal chamber of the central pontoon, while the extended horizontal chamber of the end pontoons will extend beneath the ends of the horizontal chamber of the main pontoon. In this position of the parts, with the relative construction of the end pontoons such that their side walls will form downward continuations of those of the main pontoon, the former will be given great stability and will be enabled to effectively support and raise the main pontoon above the water-line without danger of tipping over.

The effect of the construction described is to provide the ends of the side walls of the main pontoon with two undercuts or recesses, one above the other, respectively, at the angles of the surfaces 5 and 7 and 4^a and 6 and to form the ends of the side walls of the end pontoons so that they will enter or fit in the upper recesses when the sections are connected to form a dock and into the lower recesses when the central pontoon is supported by the end pontoons to dry-dock the former, the floors of the said sections being so situated in relation to these recesses that they will all be on the same level when the walls of the end pontoons are seated in the upper recesses.

The sections of the dock may be connected together in any appropriate manner which

will admit of their disconnection at will; but I propose to adopt the following construction as suitable for the purpose in view.

Referring to Fig. 3, it will be observed that the side platings of the ends of the walls of the main pontoons are extended downward some distance below the under sides of the horizontal surfaces 5 and 4^a and have bolted to their opposite sides longitudinally-extending angle-irons 15, having their projecting flanges seated on the upper ends of I-beams 16, extending longitudinally along the upper surface of the side walls of the end pontoons and along the extended floor of the same and firmly secured to said parts. The abutting flanges of the angle-irons and L-beams are connected together by bolts 17, passed through said flanges at intervals, as clearly shown in the drawings. This construction constitutes a firm connection between the main and end pontoons and affords ample room between the parts for access of workmen to the bolts on the adjacent edges of the beams and angle-irons.

The dock may be equipped with a suitable pumping mechanism, many of which are known in the art, by means of which the water may be admitted to the sections or expelled therefrom, according as it is desired to raise or lower them. By reason, however, of the relative construction of the sections which adapts them to be connected in the relations described I have found that the pumping mechanism of the main pontoon may be so arranged that the end pontoons may be pumped from this single pumping mechanism. I will proceed to describe the method for effecting this object. However, it will be understood that the details may be variously modified within the limits of my invention, which in this connection comprehends, broadly, the means for pumping the end sections by the pumping mechanism on the main section.

Referring particularly to Figs. 1, 5, 6, 7, and 8, it will be seen that the main pontoon is provided with pumps A B, from which main pipes C D are extended in the horizontal chamber to the opposite ends of the same and through these ends, at which points they are provided with valves F. These main pipes when the pumps are operated receive the water from the main pontoon and discharge the same to the outside. Near their ends each of the main pipes has a branch pipe G extending upward from a point inward of the valve F, and this branch pipe is passed through the side of the chamber and terminates on the outside at a point above the water-line, as shown in Fig. 1. The end pontoons are each provided with a main longitudinal pipe H, extended through the inner end of the chamber, at which point it is provided with a valve I. From this main pipe a branch pipe K is extended upward and then longitudinally inward through the end of the side wall and on a level with the exposed end of the pipe G when the main pontoon is docked

on the end pontoons, as shown in Fig. 5. Ad-
 jacent to its end this branch pipe K is pro-
 vided with a valve L, and where it joins the
 main pipe H it is provided with a valve M,
 5 Fig. 8. The exposed ends of the branch pipes
 K and G are adapted to be connected to-
 gether when the middle pontoon is docked,
 which connection is in the form of a rubber
 hose N or any suitable connection which will
 10 admit of the relative movement of the sec-
 tions. In order that the exposed end of pipe
 K may be brought in line with pipe G, the
 side walls of the end pontoons are continued
 outward beyond the walls of the middle sec-
 15 tion, as shown in Fig. 7. This extension of
 the walls gives the end sections greater sta-
 bility.

With the connection between the pontoons
 made in the manner described there will be
 20 formed an air-pocket in the branch pipes,
 which will necessitate a means for priming
 the pumps, and this is accomplished by provid-
 ing the drainage-pump O of the main pontoon
 with a connection P in the form of a pipe ex-
 25 tended through the side walls of the pontoon
 and communicating with the branch pipe G,
 an opening *g* being provided in said pipe for
 the escape of air.

When starting to pump, the branch pipes
 30 are filled with water by the operation of the
 drainage-pumps to destroy the air-pocket,
 after which, the main pumps being operated,
 the water will be drawn by them through the
 main pipes and through the branch pipes
 35 connecting the sections or pontoons, thereby
 drawing the water from the end pontoons.
 During this operation valves F and I are
 closed and valves L and a valve Q in the
 drainage-pipe opened.

When the sections of the dock are connect-
 ed together end to end, as shown in Fig. 1,
 the ends of main pipe D of the central pon-
 toon is connected with the end of the main
 pipe H of the end pontoons by means of a
 45 slip-joint R, as shown in Fig. 1, which pipes
 are so situated with relation to each other
 that they will be in line when the end pon-
 toons are connected to form continuations of
 the middle pontoon. In this position of the
 50 parts with the pipes connected in this man-
 ner the operation of the main pump will
 draw the water from the end pontoons and
 from the middle pontoon. In operating the
 pumps when these pipes are connected valves
 55 I and F will be opened and the others closed.

The method of operating the dock is as fol-
 lows: In order to dry-dock the middle sec-
 tion when the parts of the dock are connect-
 ed end to end, as shown in Fig. 1, the pumps
 60 are operated and the dock as a whole pumped
 to light water-line. It is then heeled over,
 so that access may be gained to the slip-joints
 R, which are disconnected, whereupon the
 bolts connecting the sections of the dock
 65 are removed and water is let into the end
 pontoons to lower them some distance. They
 are then floated clear of the middle pontoon

and more water admitted to them to sink them,
 after which they are placed under the over-
 hanging ends of the middle pontoon in the
 70 positions shown in Fig. 5, and the branch
 pipes G and L connected. The pumping op-
 eration then begins, and as the end pontoons
 are freed of water they will rise and lift the
 middle pontoon to the position shown in Fig. 75
 5. When the work is completed on the mid-
 dle pontoon and it is desired to dock the end
 ones, the latter are first sunk and discon-
 nected from the middle pontoon and floated
 free of the same and the middle pontoon 80
 then sunk and the end pontoons finally floated
 on the same, whereupon the middle pontoon
 is pumped up, and rising will lift the end
 pontoons above the water-line.

Having thus described my invention, what 85
 I claim is—

1. In a floating dock the combination with
 a main pontoon provided with side walls
 formed at their ends with overhanging por-
 tions, of an end pontoon detachably connect- 90
 ed therewith and provided with side walls
 fitting beneath the overhanging portions of
 the walls of the main pontoon and forming
 continuations of said walls.

2. In a floating dock the combination with 95
 a main pontoon having side walls formed at
 their ends with recesses, one above the other,
 of an end pontoon having side walls formed
 at their ends to fit in either of said recesses,
 and means for securing the end pontoon de- 100
 tachably to the main pontoon when fitted in
 the upper recess.

3. In a floating dock the combination with
 a main pontoon provided with side walls
 formed at their ends with undercuts, one 105
 above the other, of end pontoons provided
 with side walls and a flooring extending in-
 ward beyond the same, the inner ends of said
 side walls of the end pontoons being adapted
 to fit in the upper undercut when the sections 110
 are connected to dock ships, and adapted to
 fit in the lower undercut when the central
 pontoon is to be dry-docked on the end pon-
 toons.

4. In a floating dock the combination with 115
 a main central pontoon provided with a floor-
 ing and side walls, of two end pontoons de-
 tachably connected thereto and provided with
 side walls and a flooring extending inward
 beyond the ends of the same, said floorings 120
 and walls of the pontoons forming continua-
 tions of those of the main pontoon, and said
 end pontoons being adapted to be assembled
 in such relation to the main pontoon that the
 extended flooring will project beneath the 125
 main pontoon, and the side walls will form
 continuations of those of the main pontoon.

5. In combination with a main central pon-
 toon having side walls overhanging the ends
 of the same, end pontoons detachably con- 130
 nected with the main pontoon and provided
 with side walls extending beneath and form-
 ing a horizontal longitudinal continuation of
 the walls of the main pontoon, the said end

pontoons being adapted to be so assembled in relation to the main pontoon that the side walls of the former will form a downward continuation of those of the main pontoon, and the main pontoon will be supported by said end pontoons.

6. In a floating dock the combination with the main pontoon, of end pontoons detachably connected therewith, a pumping mechanism on the main pontoon, and means for effecting the pumping of the end pontoons from the mechanism on the main pontoon.

7. In a floating dock the combination with a main pontoon, of end pontoons detachably connected with the same, a pumping mechanism on the main pontoon, and means for connecting said pumping mechanism with the end pontoons.

8. In a floating dock the combination with a main central pontoon, of two end pontoons adapted to be detachably connected with the main pontoon to form a continuation of the same, a pumping mechanism on the main

pontoon, means for connecting said pumping mechanism with the end pontoons when the sections are connected to form continuations of each other, means for assembling the end pontoons in relation to the main pontoon so that the latter will be supported by the end pontoons and dry-docked, and means for connecting the pumping mechanism of the main pontoon with the end pontoons when the sections are so assembled.

9. In a floating dock the combination with detachable sections or pontoons, of a pumping mechanism on one of said sections and connections between the sections; whereby the other section may be pumped by said mechanism.

In testimony whereof I hereunto set my hand, this 18th day of February, 1903, in the presence of two attesting witnesses.

HJALMAR HYLANDER.

Witnesses:

S. ANDERSON,
G. STYRLANDER.