

(No Model.)

**E. CARTWRIGHT.**  
**BLAST FEEDING APPARATUS FOR FURNACES.**

No. 525,045.

Patented Aug. 28, 1894.

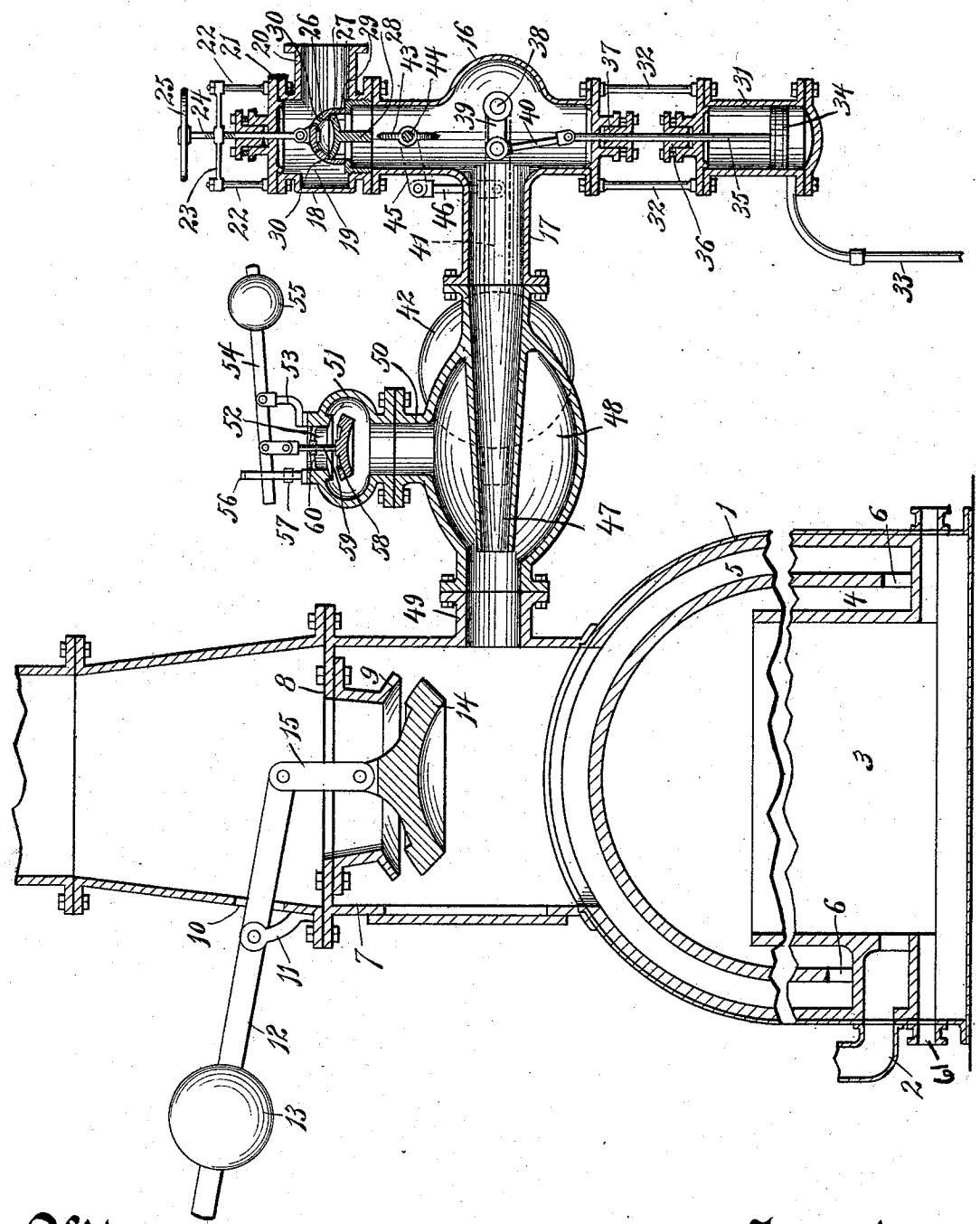

Witnesses.  
*A. H. King*  
*Anna V. Faust*

Inventor.  
*Edwin Cartwright,*  
By *Benedict & Morsell*  
Attorneys.

# UNITED STATES PATENT OFFICE.

EDWIN CARTWRIGHT, OF MILWAUKEE, WISCONSIN, ASSIGNOR OF ONE-HALF TO WILLIAM DOYLE, OF SAME PLACE.

## BLAST-FEEDING APPARATUS FOR FURNACES.

SPECIFICATION forming part of Letters Patent No. 525,045, dated August 28, 1894.

Application filed March 19, 1894. Serial No. 504,117. (No model.)

### *To all whom it may concern:*

Be it known that I, EDWIN CARTWRIGHT, of Milwaukee, in the county of Milwaukee and State of Wisconsin, have invented a new and useful Improvement in Blast-Feeding Apparatuses for Furnaces, of which the following is a description, reference being had to the accompanying drawing, which is a part of this specification.

10 My invention has relation to blast feeding apparatuses for furnaces.

The object of the invention is to provide a simple and inexpensive apparatus for feeding a blast of steam, or steam and air, to a stove for the purpose of thoroughly heating the blast preparatory to its passage from the stove to the furnace.

The invention consists of the devices and parts, or their equivalents, as hereinafter more fully described and claimed.

In the accompanying drawing, the figure represents, in vertical section, the stove, said stove being broken away lengthwise, and also in vertical section the device connected therewith for feeding the steam and commingled air into the stove.

Referring to the drawing, the numeral 1 indicates the stove which is connected to the tuyere of the furnace by a pipe 2. This stove is of the ordinary construction, and consists of an inner space 3 which communicates with the pipe 2, an annular space 4 surrounding the inner space, and a second space 5 surrounding space 4, and extending over and covering the top of space 3, said space 5 having communication with space 4 through the lower opening 6.

Surmounting the top of the stove is a cupola 7, which is provided with an internal centrally apertured plate 8, from which depends an annular valve seat 9. Passing through an elongated slot 10 in the cupola, and pivoted medially on an arm 11 is a lever 12, said lever provided upon its outer end with a weight 13, and having its inner end connected to a valve 14 through a link 15. The cupola, as shown in the drawing, is in open communication with the outer space 5 of the stove.

Referring now particularly to the feeding

mechanism, the numeral 16 indicates a casing, from which projects medially a pipe 17. To the upper end of the casing 16 is secured a coupling 18 forming a chamber 19, from which chamber projects a pipe 20, said pipe adapted to be coupled or secured to a pipe (not shown) leading from a suitable source of steam supply. The top plate 21 has extending upward therefrom standards 22, 22, which standards are connected by a cross bar 23, said cross bar provided with a central screw threaded aperture, through which a threaded valve stem 24 passes, said valve stem operated by a hand wheel 25 secured to its upper end. To the lower end of the valve stem is secured a dome-shaped apertured valve 26, the lower end of which is adapted to rest upon a valve seat 27 at the upper end of the casing 16. Within the upper portion of the casing 16 is secured a plate 28, which passes through the top opening of said casing, and is formed at its upper end into a dish shaped or concave portion 29. The valve 26 is provided with an interior shoulder 30, which when the valve is properly seated as shown in the drawing, rests upon the edge of the concave portion 29. It is obvious that when steam enters the chamber 19 it will pass through the apertures of the dome-shaped valve 26, and the pressure of the same will be exerted against the concave portion 29.

The numeral 31 indicates a lower cylinder, which cylinder is connected to the lower end of the casing 16 by means of rods 32. The cylinder is in communication with the blast furnace by means of a pipe 33. Within the cylinder works a piston-head 34, the piston-stem 35 thereof passing through stuffing-boxes 36 and 37, respectively, in the adjacent ends of the cylinder and casing. Turning within the casing is a short shaft 38, said shaft provided with a crank 39 which is connected to the piston-stem 35 by means of a link 40. The shaft 38 extends laterally beyond the outside of the casing and connects with an arm 41, said arm carrying on its outer end a weight 42. Within the casing 16, near the upper end thereof, is a throttle valve 43, said valve mounted upon a shaft 44 which extends laterally beyond the casing

and is provided with an end crank 45, said crank connected with the arm 41 by means of a link 46.

5 Coupled to the pipe 17 of the casing 16, or, if preferred, formed in one piece therewith is a nozzle 47, the end of said nozzle surrounded by a chamber 48, the end of said chamber, in turn, bolted to a coupling 49 projecting from the cupola 7. The casing of the chamber 48  
10 is provided medially with an upward-projecting extension 50, to which is bolted another casing, forming a supplemental chamber 51, which is provided with an upper opening 52. An arm 53 projects upward from the casing of the chamber 51, to which arm is pivoted a lever 54, one end of said lever provided with a weight 55, and the opposite end passing through an elongated slot in another arm 56, the extent of movement of this end  
20 being limited by means of a block, or blocks, similar to 57, placed within the slot. Adapted to work against the seat of the opening 52 of chamber 51, is a valve 58, the stem 59 of said valve passing through a guide 60, and connected medially to the lever 54.

To thoroughly understand the application of my invention, it is necessary to call attention to the fact that in connection with a blast furnace as ordinarily constructed, a large bell is employed which incloses the furnace at the top, and is used for the purpose of forcing the gas down a large tube into a channel or chamber beneath the surface of the ground, which channel or chamber feeds  
35 a lower opening similar to 61, shown in connection with the stove 1 illustrated in the accompanying drawing, said feed being accomplished by means of a stand-pipe, which is connected up to the opening 61 whenever it is desired to feed the gas to the stove 1, for the purpose of heating said stove. When it is desired to cut off the feed of gas a slide valve is closed at the base of the stand-pipe. This channel feeds the gas to the stove, and  
45 when said stove has become sufficiently heated thereby, the gas is turned off, and the blast introduced.

In the operation of my invention, shown in the accompanying drawing steam is allowed  
50 to pass into the chamber 19. The valve 26 is raised by means of the hand-wheel 25, and the steam, of course, is free to pass to the nozzle 47, and to be ejected forcibly therefrom for passage into the cupola 7 of the stove. As the steam is thus ejected from the nozzle a vacuum is formed in the chamber 48, and the moment this vacuum is formed the pressure of the external air on the valve 58 will force said valve down away from its seat, against  
60 the action of the weight 55, and allow the entrance of the air. The air thus entering the chamber 51 will be drawn into chamber 58 by the suction of the steam, whereby the commingled steam and air will enter the cupola.  
65 In thus entering the cupola, the blast acts to close the valve 14, and thereby prevents the escape outward of said steam and air. This

valve 14 is normally open as shown in the drawing, for the purpose of furnishing a draft for the escape of the heating gases while heating up the stove. The associated steam and air pass through the opening of the cupola, and enter the space 5. It circulates around said space, and then passes through the opening 6 into the space 4, and from said latter space into the space 3. While thus circulating around in the passages of the stove, the associated steam and air are thoroughly heated, and enter the furnace through the pipe 2 in this heated condition. It is obvious  
70 that the passage of this hot steam and air into the furnace has the effect of creating a most intense combustion. The commingling of the air with the steam is not essential to successful results, but its use in connection with the steam is preferable, inasmuch as a more rapid combustion is caused thereby. When the pressure in the blast furnace becomes too great, it is of course necessary that the amount of steam ejected from the nozzle should be diminished. Therefore, I so arrange the piston head 34 in the cylinder 31 that when the pressure in the furnace reaches a certain point, for instance, a pressure of eight pounds, the piston head 34 will be elevated. As the piston  
75 head is elevated, the piston-stem 35 thereof, through the intermediate connections, acts on the throttle valve, so as to bring said valve toward a horizontal position, and thereby diminish the supply of steam passing to the nozzle. When the pressure in the furnace is reduced, the weight 42, of course, returns the piston head 34 to its normal position.

Having thus described my invention, what I claim, and desire to secure by Letters Patent, is—

1. In a blast feeding apparatus for furnaces, the combination, of a stove having communication with a furnace, an ejector for ejecting steam into the stove, whereby said steam is heated prior to its passage into the furnace, and means controlled by the pressure within the furnace for regulating the amount of steam supplied, substantially as set forth.

2. The combination, of a hot blast stove having communication with a furnace, whereby gas is admitted to said stove for heating the same preparatory to forcing a blast there-through, a blast chamber having communication with the stove, said communicating chamber provided with an air opening, a valve for said opening, a steam ejecting nozzle entering the blast chamber, and adapted to force steam into the stove after the stove has become sufficiently heated, and after the supply of gas thereto has been cut off, and means for controlling the valve, whereby when a blast of steam is discharged through the nozzle said valve will be opened for the admission of air, substantially as set forth.

3. The combination of a hot-blast stove having communication with a furnace, whereby gas is admitted to said stove for heating the same preparatory to forcing a blast there-

through, a blast chamber having communication with the stove, said communicating chamber provided with an air opening, a medially pivoted lever provided at one end with a weight, a valve for controlling the air opening, the stem of said valve connected to the lever, and a steam ejecting nozzle entering the blast chamber and extending across the valve opening thereof, and adapted, after the stove has become sufficiently heated, and the supply of gas thereto cut off, to discharge the steam, for passage into the stove, in advance of the air opening, whereby a vacuum is formed back of the discharge, causing the air valve to be opened by the pressure of the exterior air, substantially as set forth.

4. The combination of a stove, a blast casing having communication with the stove and adapted to feed the blast thereto, a throttle valve within the casing, a cylinder connected to the blast furnace by means of a pipe, and a piston-head working in the cylinder, the piston-stem thereof having connection

with the throttle valve, whereby when the piston-head is raised by the pressure in the furnace, the throttle valve is turned, and the supply of steam regulated, substantially as set forth.

5. The combination of a stove, a blast casing having communication with the stove and adapted to feed the blast thereto, a cylinder connected to the blast furnace by means of a pipe, a transverse crank shaft within the casing, a link connecting the crank thereof to the stem of the piston-head, a weighted arm connected to the outer end of the crank shaft, a transverse shaft carrying a throttle valve, said shaft provided on its exterior end with a crank, and a link connecting said crank with the weighted arm, substantially as set forth.

In testimony whereof I affix my signature in presence of two witnesses.

EDWIN CARTWRIGHT.

Witnesses:

ARTHUR L. MORSELL,  
ANNA V. FAUST.