



(11) **EP 2 312 975 B1**

(12) **EUROPEAN PATENT SPECIFICATION**

(45) Date of publication and mention of the grant of the patent:
15.08.2012 Bulletin 2012/33

(21) Application number: **09784628.1**

(22) Date of filing: **23.06.2009**

(51) Int Cl.:
A47G 29/124^(2006.01) A47G 29/126^(2006.01)

(86) International application number:
PCT/GB2009/001576

(87) International publication number:
WO 2010/007346 (21.01.2010 Gazette 2010/03)

(54) **LETTERBOX ASSEMBLY LOCKING MEANS DEVICE**

VERRIEGELUNGSMITTELVORRICHTUNG FÜR EINEN BRIEFKASTEN

DISPOSITIF DE VERROUILLAGE DE BOÎTE AUX LETTRES

(84) Designated Contracting States:
AT BE BG CH CY CZ DE DK EE ES FI FR GB GR HR HU IE IS IT LI LT LU LV MC MK MT NL NO PL PT RO SE SI SK TR

(30) Priority: **16.07.2008 GB 0812965**
18.02.2009 GB 0902688

(43) Date of publication of application:
27.04.2011 Bulletin 2011/17

(73) Proprietor: **The Letterbox Guvnor Limited**
Cheshire SK1 3TL (GB)

(72) Inventor: **EVANGELOU, Marios**
Stockport
Cheshire SK2 6AF (GB)

(74) Representative: **Walker, Ross Thomson**
Forresters
Skygarden
Erika-Mann-Strasse 11
80636 München (DE)

(56) References cited:
DE-U1-202005 000 570 DE-U1-202007 014 456
GB-A- 2 198 184 GB-A- 2 208 528

EP 2 312 975 B1

Note: Within nine months of the publication of the mention of the grant of the European patent in the European Patent Bulletin, any person may give notice to the European Patent Office of opposition to that patent, in accordance with the Implementing Regulations. Notice of opposition shall not be deemed to have been filed until the opposition fee has been paid. (Art. 99(1) European Patent Convention).

Description

Field of Technology

[0001] This invention relates to letterbox security and more particularly, but not exclusively, to letterboxes and letterbox assemblies that are suitable for installation in an external door or wall structure of domestic or industrial properties with security locking means which give protection against letterbox crime.

[0002] Letterboxes are an essential item used by domestic households as well as businesses, providing unattended access for the delivery of items sent through the postal services. However letterboxes are detrimental to the basic security of a home or business, for example, it is already known that arsonists start fires in homes and businesses by pouring in flammable liquids through letterboxes, it is also known that burglars and vandals peer through letterboxes in order to determine whether anyone is at home, prior to breaking into the premises.

[0003] Thieves in particular have been known to have "Fished" car keys from hall tables again by accessing the inside of the house through the letterbox and are usually targeted at homes where there are expensive cars in the driveway. Also there is an event that takes place annually by way of Guy Fawkes night where fireworks are deliberately thrown through letterboxes with disastrous results.

[0004] It is also known that in extreme cases criminals have in fact used letterboxes to shoot pellets from air pistols at the occupants within a household.

[0005] Another disadvantage of current letterboxes is that they are open for any person to pass unwanted items such as advertising literature. As will be appreciated, this is most inconvenient for occupants who are absent from home for example - on holiday.

[0006] In the light of the above problems, it is desirable for a letterbox to be only opened at certain times and to be closed at such other times for example - such as night time or when the occupants are on holiday and they have made arrangements for the mail to be held for collection at the local Post Office on their return from holiday.

[0007] GB2208528A describes a protective device for a letter box according to the preamble of claim 1. It is an object of the present invention to address at least some of the disadvantages of prior art solutions by providing a letterbox assembly security device that may be manufactured as an integral part of a letterbox assembly and/or provide a simple stand alone device which may be easily installed for use with existing letterboxes which offer protection when operable to make it impossible to open the internal letter plate flap from the outside.

[0008] According to the present invention there is provided a restraining device suitable for vertical mounting at right angle to the internal letter flap plate of conventional letterbox assemblies.

[0009] Also according to the present invention there is provided an alternative to the above by way of an inte-

grated letterbox locking means device suitable for use within a letterbox assembly and comprising restraining devices positioned at either right angle adjacent sides to the internal letter flap plate of a letterbox assembly.

[0010] In accordance with the present invention there is provided a restraining device for the flap of a letterbox comprising:

a support member which, in use, is securable adjacent a letterbox assembly or letterbox; and

a stop member supported by said support member and extending from the support member, wherein the position of the stop member relative to the letterbox flap is adjustable by way of an arcuate slot provided by the support member and the stop member is moveable along the length of the slot and is releasably fixable at any point along the length of the slot, such that, in use, at least a portion of the stop member can restrict the degree by which the letterbox flap can open and characterised in that

the stop member comprises either :

a head member which includes a threaded shaft extending from one end thereof, and

an elongate member which includes a threaded bore which can receive the threaded shaft of the head member such that, in use, the stop member's position on the support member is fixable by way of the clamping action of the head member and elongate member;

or

an elongate member which includes a threaded shaft extending from one end thereof, and

a head member which includes a threaded bore which can receive the threaded shaft of the elongate member such that, in use, the stop member's position on the support member is fixable by way of the clamping action of the head member and elongate member. This enables the user to adjust and reposition the stop member by simply un-tightening and re-tightening the head member.

[0011] As will be appreciated, as the position of the stop member relative to the letterbox flap is adjustable, the degree by which a letterbox flap may open can be readily and simply varied depending on the requirements of the occupant. Preferably, the head member consists of a finger screw fastener. This enables the user to adjust and reposition the stop member by simply un-tightening and re-tightening the head member.

[0012] Further preferably, the support member further includes a base member provided with at least one, pref-

erably two fixing apertures such that, in use, the lock is securable adjacent the letterbox assembly or letterbox by way of fixing means passing through said fixing aperture(s).

Further preferably, in use, the device of the present invention is secured adjacent the letterbox flap, namely, above the letterbox flap and the stop member extends downwardly therefrom such that the position of the stop member relative to the letterbox flap is adjustable such that, in use, at least a portion of the stop member can restrict the degree by which the letterbox flap can open. Advantageously, the stop member is pivotably mounted on the support member and is releasably lockable at an angular position relative to the letterbox flap such that by adjusting the angle of the stop member relative to the letterbox flap can restrict the degree by which the letterbox flap can open. Preferably, the length of the stop member is telescopically adjustable such that by adjusting the length of the stop member can restrict the degree by which the letterbox flap can open. As will be appreciated, although in the illustrated embodiment the device is secured adjacent the letterbox, that is, at a side thereof, it is to be appreciated that the device can be secured at an appropriate position above the letterbox flap, that is, to control the degree by which the letterbox flap can open. In this regard, in these unillustrated embodiments, the stop member may pivotally move relative to the letterbox flap to control the degree by which the letterbox flap may open. For example, if the stop member is locked parallel to the letterbox flap, the letterbox flap will be locked. If the stop member is then pivoted in an upwardly direction by, say 45 degrees and subsequently locked, then the letterbox will be able to partially open, and if the stop member is moved a further 45 degrees so that it extends at 90 degrees to the letterbox, the letterbox flap will be able to open fully i.e. the letterbox will be able to pivot 90 degrees from its closed position such that the opening it covers is fully open.

[0013] In another aspect of the present invention, there is provided a letterbox assembly comprising:

a letterbox flap; and
 at least one support member located adjacent to the letterbox flap; and a stop member supported by said at least one support member and extending from the said support member, wherein the position of the stop member relative to the letterbox flap is adjustable by way of an arcuate slot provided by the at least one support member and the stop member is moveable within or along the length of the slot and is releasably fixable at any point along the length of the slot such that, in use, at least a portion of the stop member can restrict the degree by which the letterbox flap can open and characterised in that the stop member comprises either

a head member which includes a threaded shaft extending from one end thereof, and

an elongate restraint which includes a threaded bore which can receive the threaded shaft of the head member such that, in use, the stop member's position on the support member is fixable by way of the clamping action of the head member and elongate restraint; or

an elongate restraint which includes a threaded shaft extending from one end thereof, and
 a head member which includes a threaded bore which can receive the threaded shaft of the elongate restraint such that, in use, the stop member's position on the support member is fixable by way of the clamping action of the head member and elongate restraint. This enables the user to adjust and reposition the stop member by simply un-tightening and re-tightening the head member.

preferably, the head member consists of a finger screw fastener. This enables the user to adjust and reposition the stop member by simply un-tightening and re-tightening the head member.

[0014] In a preferred embodiment, the assembly includes two support members which are located at opposite sides of the letterbox flap, and each support member supports a separate stop member.

Advantageously, the assembly includes two support members, which are located at opposite sides of the letterbox flap and which support a single stop member extending there between. In this embodiment it is preferable that the stop member comprises two head members which both include a threaded shaft extending from one end thereof and an elongate restraint with a threaded bore at either end thereof, such that, in use, the position of the elongate restraint between the two support members is fixable by way of the clamping action between each head member and its associated end of the elongate restraint on their associated support member. Preferably, each head member consists of a finger screw fastener. Alternatively, the stop member comprises two head members which both include a threaded bore at one end thereof and an elongate restraint with a threaded shaft extending from either end thereof such that, in use, the position of the elongate member between the two support members is fixable by way of the clamping action between each head member and its associated end of the elongate restraint on their associated support member.

Advantageously, the at least one support member is located above the letterbox flap and the stop member extends downwardly therefrom such that the position of the stop member relative to the letterbox flap is adjustable such that, in use, at least a portion of the stop member can restrict the degree by which the letterbox flap can open. In this regard, in a preferred embodiment, the stop member is pivotably mounted on the support member and is releasably lockable at an angular position relative to the letterbox flap such that by adjusting the angle of

the stop member relative to the letterbox flap can restrict the degree by which the letterbox flap can open. Further preferably, in another preferred embodiment, the length of the stop member is telescopically adjustable such that by adjusting the length of the stop member can restrict the degree by which the letterbox flap can open. As will be appreciated, although in the illustrated embodiment the at least one support member is located to the side of the letterbox flap, it is to be appreciated that the support member and its associated stop member can be secured at an appropriate position above the letterbox flap, that is, to control the degree by which the letterbox flap can open. In this regard, in these unillustrated embodiments, the stop member may pivotally move relative to the letterbox flap to control the degree by which the letterbox flap may open. For example, if the stop member is locked parallel to the letterbox flap, the letterbox flap will be locked. If the stop member is then pivoted in an upwardly direction by, say 45 degrees and subsequently locked, then the letterbox will be able to partially open, and if the stop member is moved a further 45 degrees so that it extends at 90 degrees to the letterbox, the letterbox flap will be able to open fully i.e. the letterbox will be able to pivot 90 degrees from its closed position such that the opening it covers is fully open.

[0015] In accordance with a further aspect of the present invention, there is provided a door including the device or assembly of any one of the preceding claims.

[0016] Non-limiting embodiments of the present invention will now be described by way of reference to the following figures:

Figure 1 is a perspective view of a restraining device in accordance with the present invention, viewed as a stand alone device in accordance with the present invention for use with existing letterbox assemblies or letterboxes;

Figure 2 is a perspective view of the restraining device of the present invention viewed as an integrated part of a letterbox assembly;

Figure 3 is a perspective view of the restraining device of Figure 1 viewed in use with an external door; and

Figure 4 is a perspective view of the restraining device of the present invention viewed as a integrated body section part of a letterbox assembly.

[0017] Figure 1 illustrates an example of a restraining device 10 according to the present invention. The restraining device 10 comprises a support member 1 including a base member with two vertical fixing apertures 2, which facilitate fixing of the device 10 to the inside of a door, that is, by the use of suitable fixing means such as screws, nails etc.

[0018] The base member of the support member 1 is

further provided with a near 180 degree locking means positioning arcuate slot 3. The slot is arcuate in shape. The slot 3 facilitates a finger screw fastener 4 as well as letterbox flap screw threaded positioning restraint 5. As will be appreciated, the stop member that includes the finger screw fastener 4 and restraint 5 is releasably fixable and positionable at any point along the length of the slot 3 by the clamping action of the finger screw fastener 4 and restraint 5. In this regard, the finger screw fastener 4 has a threaded shaft which, in use, is received by a threaded bore extending into the restraint 5. That is, by tightening the screw fastener 4 so that its threaded shaft moves deeper into the bore of the restraint 5 results in the adjacent and opposing ends of the fastener and restraint clamping down onto the area of the support member adjacent the slot 3. It is to be appreciated that the screw fastener 4 may instead be provided with a threaded bore with the restraint 5 being provided with a threaded shaft extending from one side thereof and suitably sized to be received by said threaded bore.

[0019] Figure 3 illustrates an example of the restraining device 10 according to the present invention fitted to the inside of a door and positioned and fixed adjacent to the side of a typically installed letterbox assembly. As will be appreciated, in other embodiments of the present invention the stand alone lock can be secured at a position above the installed letterbox assembly and/or letterbox flap.

[0020] With further reference to Figure 3, a letterbox assembly 20 includes a letterbox flap 6 which is pivotally connected to the frame of the letterbox assembly 7 by means of pivot pins (not shown). As illustrated, the letterbox flap 6 is shown in the partially open position and cannot open any further due to the letterbox flap positioning restraint 5 when finger screw fastener 4 is fully tightened. Put another way, due to the location of the stop member, which comprises the restraint 5 and fastener 4, within the slot 3, the degree to which the letterbox flap can open is limited.

[0021] As will be appreciated, the letterbox flap 6 can be locked in any locking position from fully closed to fully open depending on where the positioning restraint 5 and finger screw fastener 4 is positioned within the body positioning slot 3 thus governing how much open or closed the occupant would like letterbox flap position to be fixed at. Put another way, the degree by which the letterbox flap can open is dependent on where the stop member is fixably located along the length of the slot 3. For example, and as illustrated, the stop member comprising the restraint 5 and fastener 4 is located about half way down the slot 3 and, as such, the flap can open up to about 45 degrees. As will be appreciated, if the fastener 4 of the stop member was un-tightened, and the stop member was relocated to the bottom of the slot 3 furthest away from the top end of the letterbox flap, which is attached to the assembly by way of the pivot pins, and then re-tightened, then the letterbox flap would not be able to open at all.

[0022] As will be appreciated, the restraining device 10 as depicted in Figures 1 and 3 may be used at either side of the letterbox assembly in a left or right hand position by rotating the complete letterbox locking means device 10 by 180 degrees. It is also to be appreciated that it is also possible to include a separate restraining device 10 adjacent both sides of the letterbox flap for added security.

[0023] Figure 4 illustrates a further example of a restraining device 100 according to the present invention comprising an integrated body section 8, which is a complete injection moulded part to be installed as part of a complete letterbox assembly. As illustrated in Figure 2, the letterbox locking means device 100 is provided with two stop members 11, each associated with a separate stop member each comprising a finger screw fastener 4 and letterbox flap screw threaded positioning restraint 5, at either side of the letterbox flap 6. Each stop member 11 is provided with an arcuate shaped slot 3 which define the path along which the stop member 11 can move. As will be appreciated, the manner in which the stop member works and engages with the support member is the same as the stand alone device 10 of Figures 1 and 3.

[0024] Although the assembly 10 of Figures 2 and 4 included two separate stop members, it is to be appreciated that the supports 11 may support a single stop member suspended and held between the two support members. In this connection, the stop member could comprise a single elongate member with a separate finger screw fastener at either end thereof. Basically by way of further reference to Figure 2, instead of having two restraints 5, you would only have a single restraint or elongate member extending the whole length of the letterbox flap and supported at either end by a separate support member 11.

[0025] It is also to be appreciated that in other embodiments of the present invention the support member(s) can be located at a position above the installed letterbox assembly and/or letterbox flap.

[0026] When used in this specification and claims, the terms "comprises" and "comprising" and variations thereof mean that the specified features, steps or integers are included. The terms are not to be interpreted to exclude the presence of other features, steps or components.

[0027] The features disclosed in the foregoing description, or the following claims, or the accompanying drawings, expressed in their specific forms or in terms of a means for performing the disclosed function, or a method or process for attaining the disclosed result, as appropriate, may, separately, or in any combination of such features, be utilised for realising the invention in diverse forms thereof.

Claims

1. A restraining device (10) for the flap of a letterbox comprising:

a support member (1) which, in use, is securable adjacent a letterbox assembly or letterbox; and a stop member supported by said support member (1) and extending from the support member, wherein the position of the stop member relative to the letterbox flap is adjustable by way of an arcuate slot (3) provided by the support member (1) and the stop member is moveable along the length of the arcuate slot (3) and is releasably fixable at any point along the length of the arcuate slot (3) such that, in use, at least a portion of the stop member can restrict the degree by which the letterbox flap can open and **characterised in that** the stop member comprises either:

a head member (4) which includes a threaded shaft extending from one end thereof, and an elongate restraint (5) which includes a threaded bore which can receive the threaded shaft of the head member (4) such that, in use, the stop member's position on the support member (1) is fixable by way of the clamping action of the head member and elongate restraint; or an elongate restraint (5) which includes a threaded shaft extending from one end thereof, and

a head member (4) which includes a threaded bore which can receive the threaded shaft of the elongate restraint (5) such that, in use, the stop member's position on the support member is fixable by way of the clamping action of the head member and elongate restraint.

2. The device of claim 1, wherein the head member (4) consists of a finger screw fastener.
3. The device of any one of the preceding claims, wherein the support member (1) further includes a base member provided with at least one, preferably two fixing apertures (2) such that, in use, the device is securable adjacent the letterbox assembly or letterbox by way of fixing means passing through said fixing aperture(s).
4. The device of claim 1 or 3, wherein, in use, the device (10) is secured above the letterbox flap and the stop member extends downwardly therefrom such that the position of the stop member relative to the letterbox flap is adjustable such that, in use, at least a portion of the stop member can restrict the degree by which the letterbox flap can open.
5. The device of claim 4, wherein stop member is pivotably mounted on the support member (1) and is releasably lockable at an angular position relative to the letterbox flap such that by adjusting the angle of the stop member relative to the letterbox flap can restrict the degree by which the letterbox flap can

open.

6. The device of claim 4, wherein the length of the stop member is telescopically adjustable such that by adjusting the length of the stop member can restrict the degree by which the letterbox flap can open. 5
7. A letterbox assembly (20) comprising:
 a letterbox flap (6); and 10
 the restraining device (10) of any of the preceding claims.
8. The assembly of claim 7, wherein the assembly (20) includes two support members (1) which are located at opposite sides of the letterbox flap (6), and each support member supports a separate stop member. 15
9. The assembly of claim 7, wherein the assembly (20) includes two support members (1), which are located at opposite sides of the letterbox flap (6) and which support a single stop member extending there between. 20
10. The assembly of claim 9, wherein the stop member comprises two head members (4) which both include a threaded shaft extending from one end thereof and an elongate restraint (5) with a threaded bore at either end thereof, such that, in use, the position of the elongate restraint (5) between the two support members (1) is fixable by way of the clamping action between each head member and its associated end of the elongate restraint (5) on their associated support member (1) and wherein optionally and preferably, each head member consists of a finger screw fastener. 25
30
35
11. the assembly of claim 9, wherein the stop member (10) comprises two head members (4) which both include a threaded bore at one end thereof and an elongate restraint (5) with a threaded shaft extending from either end thereof such that, in use, the position of the elongate restraint (5) between the two support members (1) is fixable by way of the clamping action between each head member and its associated end of the elongate restraint (5) on their associated support member (1). 40
45
12. The assembly of claim 7, wherein the at least one support member is located above the letterbox flap and the stop member extends downwardly therefrom such that the position of the stop member relative to the letterbox flap is adjustable such that, in use, at least a portion of the stop member can restrict the degree by which the letterbox flap can open. 50
55
13. The assembly of claim 12, wherein the stop member is pivotably mounted on the support member and is

releasably lockable at an angular position relative to the letterbox flap such that by adjusting the angle of the stop member relative to the letterbox flap can restrict the degree by which the letterbox flap can open.

14. The assembly of claim 12, wherein the length of the stop member is telescopically adjustable such that by adjusting the length of the stop member can restrict the degree by which the letterbox flap can open.
15. A door including the device or assembly of any one of the preceding claims.

Patentansprüche

1. Verriegelungsvorrichtung (10) für die Klappe eines Briefkastens, umfassend:

ein Tragelement (1), das im Gebrauch neben einer Briefkastenanordnung oder einem Briefkasten gesichert werden kann; und
 einem Anschlagelement, das von dem Tragelement (1) getragen ist und sich von dem Tragelement erstreckt, wobei die Position des Anschlagelements im Verhältnis zur Briefkastenklappe mittels eines vom Tragelement (1) vorgesehenen bogenförmigen Schlitzes (3) verstellbar ist und das Anschlagelement entlang des bogenförmigen Schlitzes (3) bewegt und lösbar an einem beliebigen Punkt entlang des bogenförmigen Schlitzes (3) befestigt werden kann, so dass im Gebrauch zumindest ein Bereich des Anschlagelements den Grad beschränken kann, um den sich die Briefkastenklappe öffnen kann, und **dadurch gekennzeichnet, dass** das Anschlagelement folgendes umfasst:

entweder ein Kopfelement (4), das einen Schaft mit Gewinde einschließt, der sich von einem Ende desselben erstreckt, und eine längliche Rückhalteeinrichtung (5), die eine Bohrung mit Gewinde beinhaltet, die den Schaft mit Gewinde des Kopfelements (4) so aufnehmen kann, dass im Gebrauch die Position des Anschlagelements auf dem Tragelement (1) mittels des Klemmvorgangs des Kopfelements und der länglichen Rückhalteeinrichtung fixiert werden kann; oder
 eine längliche Rückhalteeinrichtung (5), die einen Schaft mit Gewinde einschließt, der sich von einem Ende derselben erstreckt, und
 ein Kopfelement (4), das eine Bohrung mit Gewinde einschließt, die den Schaft mit Ge-

- winde der länglichen Rückhalteeinrichtung aufnehmen kann, so dass im Gebrauch die Position des Anschlagelements auf dem Tragelement mittels des Klemmvorgangs des Kopfelements und der länglichen Rückhalteeinrichtung fixiert werden kann.
2. Vorrichtung nach Anspruch 1, wobei das Kopfelement (4) aus einem Fingerschraubenverbindungselement besteht: 5
 3. Vorrichtung nach irgendeinem der vorhergehenden Ansprüche, wobei das Tragelement (1) weiterhin ein Basiselement einschließt, das mit zumindest einer, vorzugsweise zwei Fixierungsöffnungen (2) versehen ist, so dass im Gebrauch die Vorrichtung neben der Briefkastenanordnung oder dem Briefkasten mittels einer Fixierungseinrichtung gesichert werden kann, die durch die Fixierungsöffnung(en) hindurchgeht. 10
 4. Vorrichtung nach Anspruch 1 oder 3, wobei im Gebrauch die Vorrichtung (10) über der Briefkastenklappe gesichert ist und das Anschlagelement von dieser so nach unten verläuft, dass die Position des Anschlagelements im Verhältnis zur Briefkastenklappe so verstellbar ist, dass im Gebrauch zumindest ein Bereich des Anschlagelements den Grad beschränken kann, um den sich die Briefkastenklappe öffnen kann. 15
 5. Vorrichtung nach Anspruch 4, wobei das Anschlagelement verschwenkbar auf dem Tragelement (1) angebracht ist und lösbar in einer Winkelposition im Verhältnis zur Briefkastenklappe verspannt werden kann, so dass durch Verstellen des Winkels des Anschlagelements im Verhältnis zur Briefkastenklappe den Winkel beschränken kann, um den sich die Briefkastenklappe öffnen kann. 20
 6. Vorrichtung nach Anspruch 4, wobei die Länge des Anschlagelements teleskopartig verstellbar werden kann, so dass durch Verstellen der Länge des Anschlagelements den Grad beschränken kann, um den sich die Briefkastenklappe öffnen kann. 25
 7. Briefkastenanordnung (20), umfassend: 30
 - eine Briefkastenklappe (6); und
 - die Verriegelungseinrichtung (10) nach irgendeinem der vorhergehenden Ansprüche. 35
 8. Anordnung nach Anspruch 7, wobei die Anordnung (20) zwei Tragelemente (1) einschließt, die sich auf gegenüberliegenden Seiten der Briefkastenklappe (6) befinden, und jedes Tragelement ein separates Anschlagelement trägt. 40
 9. Anordnung nach Anspruch 7, wobei die Anordnung (20) zwei Tragelemente (1) einschließt, die sich auf gegenüberliegenden Seiten der Briefkastenklappe (6) befinden und die ein einzelnes Anschlagelement tragen, das zwischen ihnen verläuft. 45
 10. Anordnung nach Anspruch 9, wobei das Anschlagelement zwei Kopfelemente (4) umfasst, die beide einen Schaft mit Gewinde, der sich von ihrem einen Ende erstreckt, und eine längliche Rückhalteeinrichtung (5) mit einer Bohrung mit Gewinde jeweils am Ende derselben einschließen, so dass im Gebrauch die Position der länglichen Rückhalteeinrichtung (5) zwischen den zwei Tragelementen (1) mittels des Klemmvorganges zwischen jedem Kopfelement und seinem zugeordneten Ende der länglichen Rückhalteeinrichtung (5) auf ihren zugeordneten Tragelement (1) befestigt werden kann, und wobei gegebenenfalls und vorzugsweise jedes Kopfelement aus einem Fingerschraubenverbindungselement besteht. 50
 11. Anordnung nach Anspruch 9, wobei das Anschlagelement (10) zwei Kopfelemente (4) umfasst, die beide eine Bohrung mit Gewinde an ihrem einen Ende und eine längliche Rückhalteeinrichtung (5) mit einem Schaft mit Gewinde, der sich jeweils von Ende derselben erstreckt, einschließen, so dass im Gebrauch die Position der länglichen Rückhalteeinrichtung (5) zwischen den zwei Tragelementen (1) mittels des Klemmvorganges zwischen jedem Kopfelement und seinem zugeordneten Ende der länglichen Rückhalteeinrichtung (5) auf ihrem zugeordneten Tragelement (1) fixiert werden kann. 55
 12. Anordnung nach Anspruch 7, wobei sich das zumindest eine Anschlagelement über der Briefkastenklappe befindet und sich das Anschlagelement von dieser nach unten erstreckt, so dass die Position des Anschlagelements im Verhältnis zur Briefkastenklappe verstellbar ist, so dass im Gebrauch zumindest ein Bereich des Anschlagelements den Grad beschränken kann, um den sich die Briefkastenklappe öffnen kann.
 13. Anordnung nach Anspruch 12, wobei das Anschlagelement verschwenkbar auf dem Tragelement angebracht ist und lösbar in einer Winkelposition im Verhältnis zur Briefkastenklappe verspannt werden kann, so dass durch Verstellen des Winkels des Anschlagelements im Verhältnis zur Briefkastenklappe den Winkel beschränken kann, um den sich die Briefkastenklappe öffnen kann.
 14. Anordnung nach Anspruch 12, wobei die Länge des Anschlagelements teleskopartig verstellbar werden kann, so dass durch Verstellen der Länge des Anschlagelements den Grad beschränken kann, um

den sich die Briefkastenklappe öffnen kann.

15. Tür einschließlich der Vorrichtung oder Anordnung nach irgendeinem der vorhergehende Ansprüche.

Revendications

1. Un dispositif de retenue (10) pour le rabat d'une boîte aux lettres, se composant de ce qui suit :

un élément de support (1) qui, pendant l'utilisation, peut être assujéti de manière adjacente à un ensemble boîte aux lettres ou à une boîte aux lettres ; et

un élément de butée soutenu par ledit élément de support (1) et s'étendant depuis l'élément de support, la position de l'élément de butée par rapport au rabat de la boîte aux lettres étant réglable au moyen d'une fente arquée (3) fournie par l'élément de support (1) et l'élément de butée pouvant se déplacer le long de la fente arquée (3) et pouvant être fixé de manière libérable à n'importe quel endroit le long de la fente arquée (3) de sorte que, pendant l'utilisation, au moins une partie de l'élément de butée puisse restreindre le degré d'ouverture du rabat de la boîte aux lettres et **se caractérisant par le fait que** l'élément de butée comporte soit :

un élément de tête (4) comportant une tige filetée partant d'une de ses extrémités et une retenue allongée (5) comportant un trou fileté pouvant recevoir la tige filetée de l'élément de tête (4) de telle sorte que, pendant l'utilisation, la position de l'élément de butée sur l'élément de support (1) puisse être assujéti par l'action de serrage de l'élément de tête et de la retenue allongée ; soit une retenue allongée comportant une tige filetée partant d'une de ses extrémités et un élément de tête (4) comportant un trou fileté pouvant recevoir la tige filetée de la retenue allongée (5) de telle sorte que, pendant l'utilisation, la position de l'élément de butée sur l'élément de support puisse être assujéti par l'action de serrage de l'élément de tête et de la retenue allongée.

2. Le dispositif de la revendication 1, dans lequel l'élément de tête (4) se compose d'un élément de fixation à vis à serrage à main.
3. Le dispositif de n'importe laquelle des revendications précédentes, dans lequel l'élément de support (1) comporte également un élément de base muni d'au moins une, et de préférence deux, ouvertures de fixation (2) de sorte que, pendant l'utilisation, le

dispositif puisse être assujéti de manière adjacente à l'ensemble boîte aux lettres ou à la boîte aux lettres au moyen d'un élément de fixation passant par la ou les ouvertures de fixation.

5

4. Le dispositif de la revendication 1 ou 3, dans lequel, pendant l'utilisation, le dispositif (10) est assujéti au-dessus du rabat de boîte aux lettres et l'élément de butée en part vers le bas de telle manière que la position de l'élément de butée par rapport au rabat de boîte aux lettres puisse être réglée pour que, pendant l'utilisation, au moins une partie de l'élément de butée puisse restreindre le degré d'ouverture du rabat de boîte aux lettres.

10

15

20

25

30

35

5. Le dispositif de la revendication 4, dans lequel l'élément de butée est monté de manière pivotante sur l'élément de support (1) et est verrouillable de manière libérable à une position angulaire par rapport au rabat de boîte aux lettres de telle manière que, en réglant l'angle de l'élément de butée par rapport au rabat de boîte aux lettres, il soit possible de restreindre le degré d'ouverture du rabat de boîte aux lettres.

6. Le dispositif de la revendication 4, dans lequel la longueur de l'élément de butée est télescopiquement réglable de telle manière que, en réglant la longueur de l'élément de butée, il soit possible de restreindre le degré d'ouverture du rabat de boîte aux lettres.

7. Un ensemble boîte aux lettres (20) se composant de ce qui suit :

un rabat de boîte aux lettres (6) ; et
le dispositif de retenue (10) de n'importe laquelle des revendications précédentes.

40

45

8. L'ensemble de la revendication 7, dans lequel l'ensemble (20) comporte deux éléments de support (1) situés sur des côtés opposés du rabat de boîte aux lettres (6) et chaque élément de support soutient un élément de butée séparé.

9. L'ensemble de la revendication 7, dans lequel l'ensemble (20) comporte deux éléments de support (1) situés sur des côtés opposés du rabat de boîte aux lettres (6) et soutenant un seul élément de butée entre eux.

10. L'ensemble de la revendication 9, dans lequel l'élément de butée comporte deux éléments de tête (4) qui sont chacun munis d'une tige filetée partant d'une de leurs extrémités et une retenue allongée (5) avec un trou fileté à une extrémité, de telle manière que, pendant l'utilisation, la position de la retenue allongée (5) entre les deux éléments de support (1) puisse

être assujettie par l'action de serrage entre chaque élément de tête et son extrémité associée de la retenue allongée (5) sur son élément de support associé (1) et dans lequel, en option et de préférence, chaque élément de tête se compose d'un élément de fixation à vis à serrage à main. 5

11. L'ensemble de la revendication 9, dans lequel l'élément de butée (10) comporte deux éléments de tête (4) qui comprennent tous les deux un trou fileté à une extrémité et une retenue allongée (5) avec une tige filetée partant d'une de ses extrémités, de telle manière que, pendant l'utilisation, la position de la retenue allongée (5) entre les deux éléments de support puisse être assujettie par l'action de serrage entre chaque élément de tête et son extrémité associée de la retenue allongée (5) sur leur élément de support associé (1). 10 15
12. L'ensemble de la revendication 7, dans lequel le ou les éléments de support se trouvent au-dessus du rabat de boîte aux lettres et l'élément de butée en part vers le bas de telle manière que la position de l'élément de butée par rapport au rabat de boîte aux lettres puisse être réglée pour que, pendant l'utilisation, au moins une partie de l'élément de butée puisse restreindre le degré d'ouverture du rabat de boîte aux lettres. 20 25
13. L'ensemble de la revendication 12, dans lequel l'élément de butée est monté de manière pivotante sur l'élément de support et est verrouillable de manière libérable à une position angulaire par rapport au rabat de boîte aux lettres, de telle manière que, en réglant l'angle de l'élément de butée par rapport au rabat de boîte aux lettres, il soit possible de restreindre le degré d'ouverture du rabat de boîte aux lettres. 30 35
14. L'ensemble de la revendication 12, dans lequel la longueur de l'élément de butée est télescopiquement réglable de telle manière que, en réglant la longueur de l'élément de butée, il soit possible de restreindre le degré d'ouverture du rabat de boîte aux lettres. 40 45
15. Une porte comprenant le dispositif ou l'ensemble de n'importe laquelle des revendications précédentes. 50

55

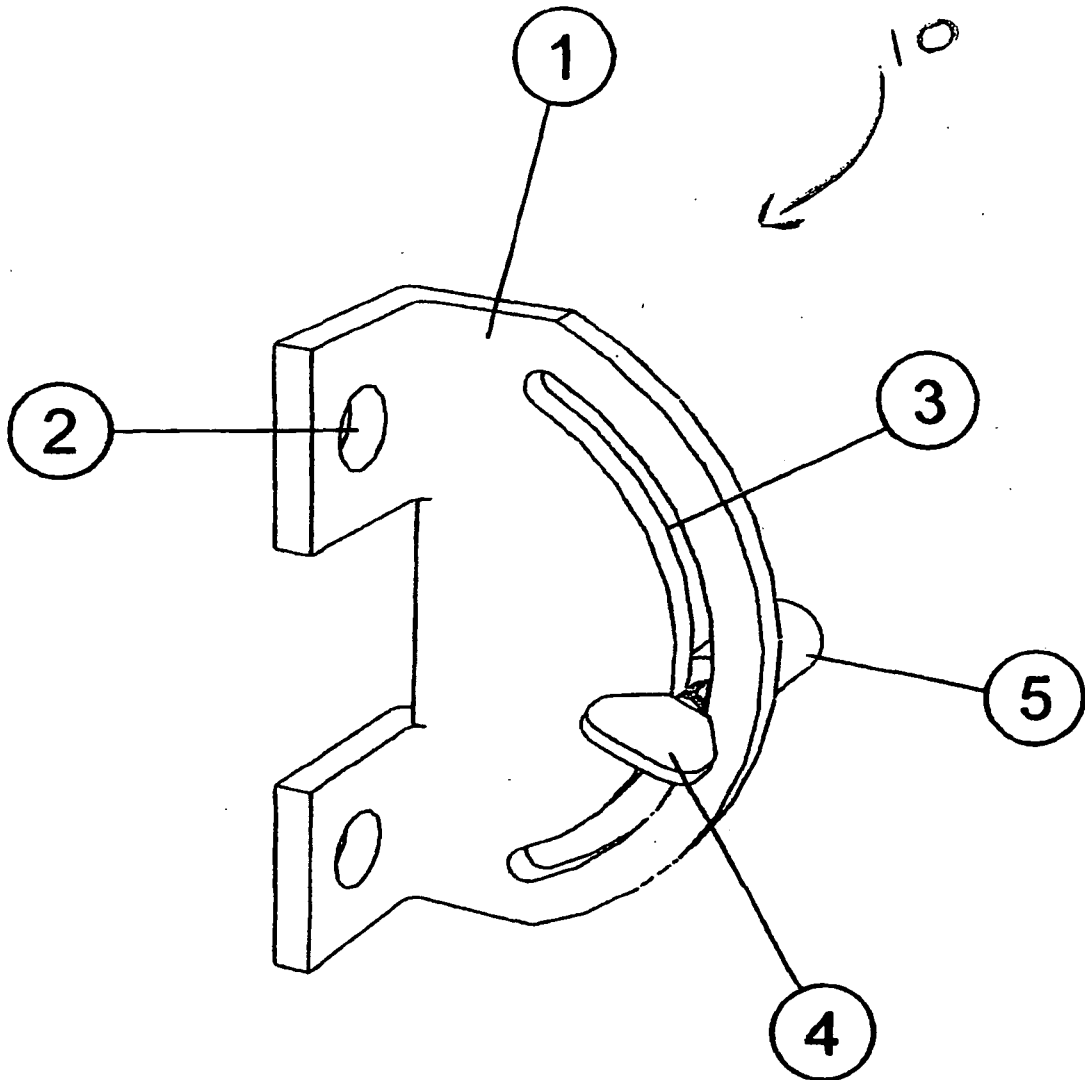

Fig 1

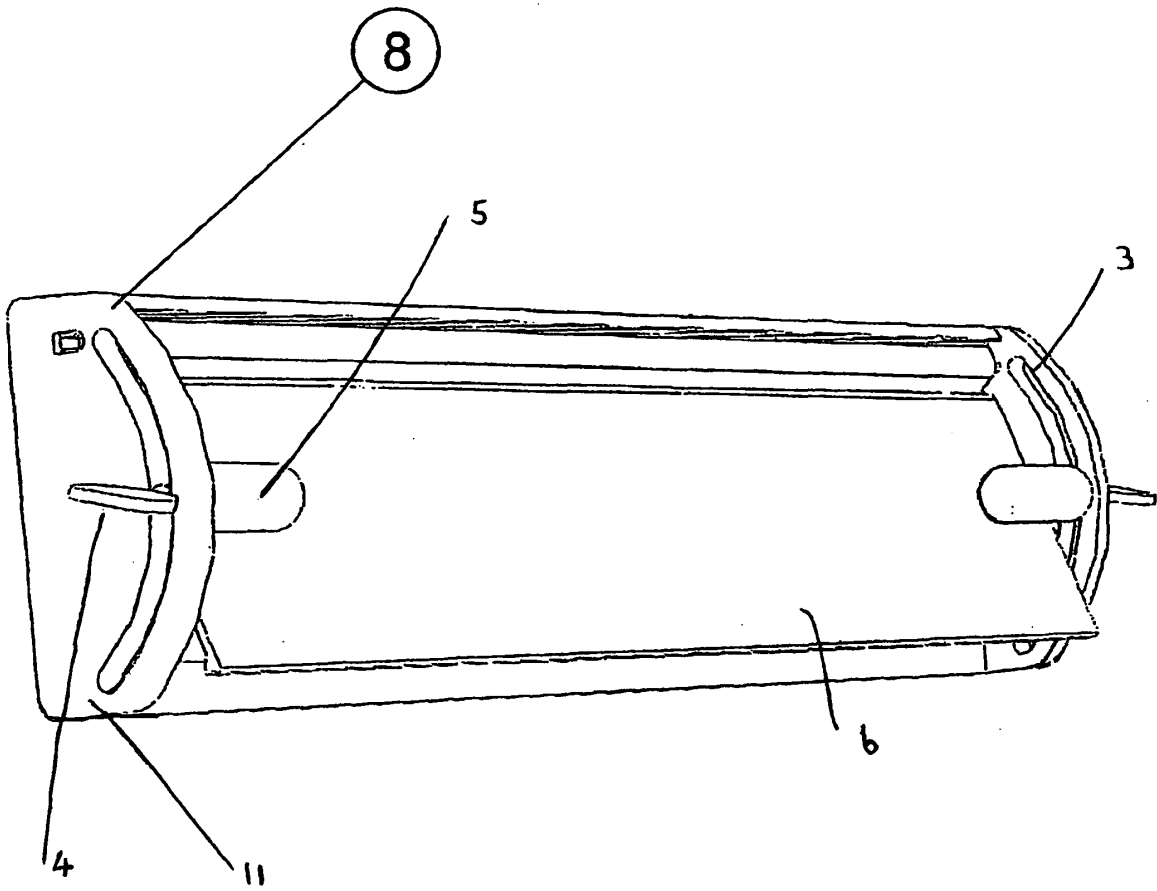

Fig 2

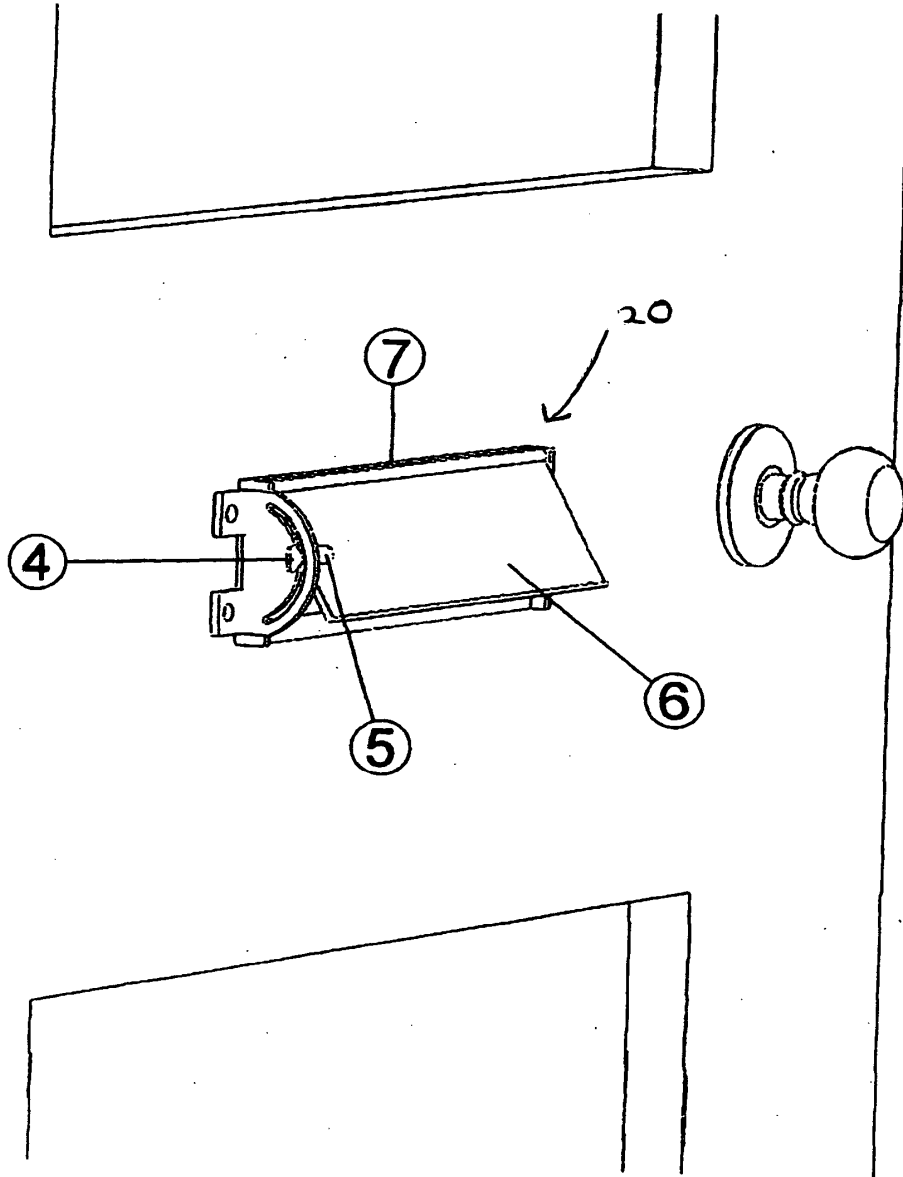

Fig 3

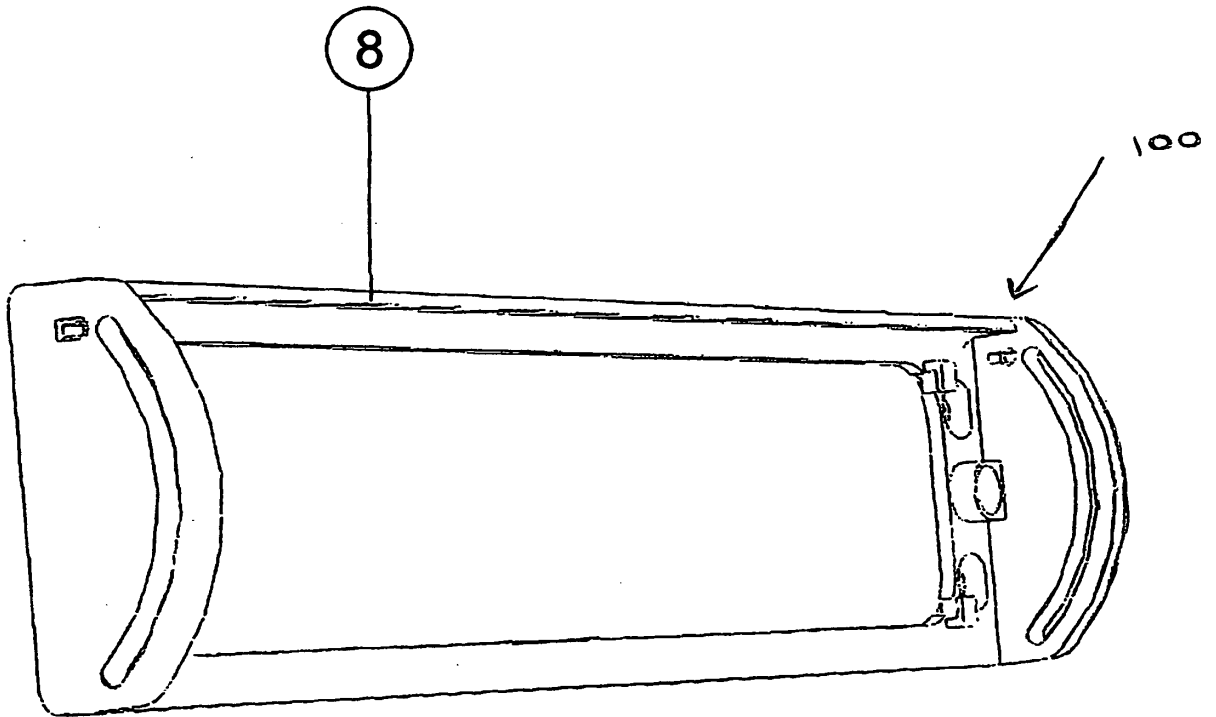

Fig 4

REFERENCES CITED IN THE DESCRIPTION

This list of references cited by the applicant is for the reader's convenience only. It does not form part of the European patent document. Even though great care has been taken in compiling the references, errors or omissions cannot be excluded and the EPO disclaims all liability in this regard.

Patent documents cited in the description

- GB 2208528 A [0007]