

C. H. HELMS.
 Machinery for Trimming the Sole-Edges of
 Boots and Shoes.

No. 212,311.

Patented Feb. 18, 1879.

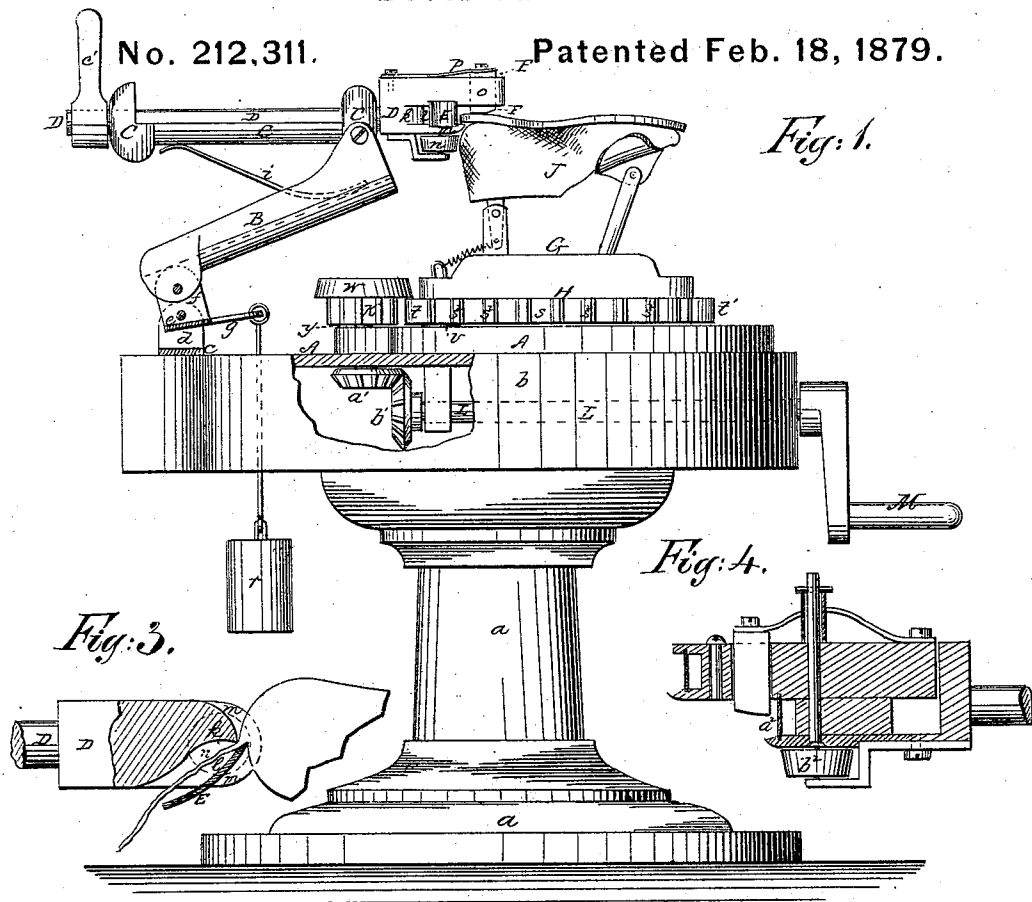
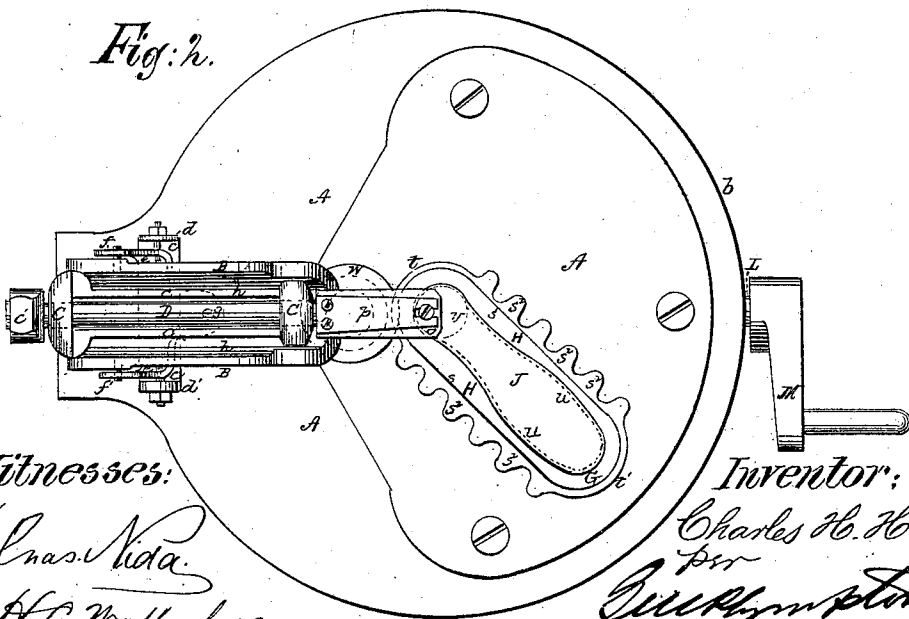

Fig: 3.

Fig: 4.

Fig: 2.



Witnesses:

Chas. Kida.
H. L. Mattenberg

Inventor:

Charles H. Helms
 per
Wm. Sympton.
 atty

UNITED STATES PATENT OFFICE.

CHARLES H. HELMS, OF POUGHKEEPSIE, ASSIGNOR TO THE NEW YORK
EDGE TRIMMER COMPANY, OF NEW YORK, N. Y.

IMPROVEMENT IN MACHINERY FOR TRIMMING THE SOLE-EDGES OF BOOTS AND SHOES.

Specification forming part of Letters Patent No. **212,311**, dated February 18, 1879; application filed
June 25, 1878.

To all whom it may concern:

Be it known that I, CHARLES H. HELMS, of Poughkeepsie, in the county of Dutchess and State of New York, have invented a new and Improved Machine for Trimming the Edges of the Soles of Boots and Shoes; and that the following is a full, clear, and exact description of the same, reference being had to the accompanying drawings, and to the letters of reference marked thereon, making part of this specification.

This invention is in the nature of an improvement in machines for trimming the edges of the soles of boots and shoes; and the invention is a machine for trimming the edges of the soles of boots and shoes, constructed with a supporting-arm hinged at one end to the table of the machine, to which supporting-arm are pivoted or hinged one or more bearings, which receive and permit to turn therein a shaft, the shaft having attached to its inner end a fixed cutter for shaving the edge of the sole, a channel-guide to enter into the channel between the sole and vamp, a roller which bears against the vamp, and a presser to bear upon the upper surface of the sole, the other end of the shaft being provided with a crank or handle whereby the cutter, &c., may be manipulated. The shoe, &c., to be trimmed is supported by a jack or device having a base with cogs on two of its sides only, the ends being free therefrom, the jack being combined with a revolving pinion, whereby the same may be operated, and with a steady-pin to regulate its motion.

In the accompanying sheet of drawings, Figure 1 represents a side view of my machine, partly in section; Fig. 2, a plan or top view of same; Fig. 3, a detail view of cutter and block, showing manner of trimming the sole; and Fig. 4, a modification showing double cutters.

Similar letters of reference indicate like parts in the several figures.

The machine which constitutes this invention is designed to pare or trim the edges of the soles of boots and shoes, so that they shall have a uniform, square, and smooth edge, and so that such an edge may be formed on the soles rapidly and with facility.

In describing the machine, A is the table,

which may be of any desirable form and size, and made from any suitable material. This table may be supported by legs or by a pedestal, *a*, and case *b*. To this table, on one side and near the edge of the same, is fixed a cleat, *c*, with bearings *d d'* therein, and hinged, pivoted, or otherwise secured to the bearings *d d'* of this cleat is a second cleat, *e*, which also has bearings *f f'* and a lug, *g*, formed with or attached to it. To this last-mentioned cleat *e*, or rather to its bearings *f f'*, is fixed, by a hinged or pivotal joint, one end of an arm, B. This arm extends inward from the cleat *e* toward the center of the table A, and it is preferably of the form of a hollow semi-cylinder. Within the concavity *h* of this arm is fixed a spring, *i*, and to the inner end of the arm, by a hinge or pivotal joint, is attached at one of its ends a bearing, C. Passing through and supported by this bearing is a shaft or stem, D, to the inner end of which is rigidly fixed, in any desirable manner, a cutter, E. The cutting-edge of this cutter is substantially in line with the axis of the shaft D.

In front of the cutting-edge of the cutter is fixed a block, *k*, the space *l* between them permitting the passage of the shaving of leather as it is shaved off from the sole by the cutter, as in a carpenter's plane. Immediately below the cutter and block *k* is fixed a guide, *m*, the front edge of which projects beyond the cutter E and block *k*, and is curved and beveled, as is shown in Figs. 1 and 3. Below this guide *m*, and supported in suitable bearings, is a roller, *n*, and above the cutter E and block *k*, but somewhat in advance of the same, is fitted an adjustable presser, F. This presser has a vertical adjustment within its bearing *o*, which adjustment is regulated by a spring, *p*. To the lug *g* of the cleat *e* is fixed a counterweight, *r*, which depends therefrom, passing through the table A for that purpose.

Onto the table A is placed a jack, G, for supporting the shoe the sole of which it is desired to trim. The base H of this jack has parallel sides *s s'*, provided with cogs *s²*, and its ends *t t'* are curved and without cogs. In the under side of this base H is formed a slot, *u*, into which enters a steady-pin, *v*, fixed in the center of the table A. On the upper surface of this base is secured in any desirable

manner the last J, which is covered by the shoe to be trimmed. Onto the table A, and meshing into the cogs on the sides of the base H, is a pinion, K. This pinion has a guide, *w*, on its upper surface, which overlaps the upper surface of the cogs in the base, and tends to keep the base H in close contact with the surface of the table A and to steady the motion of the jack. The pinion K has a shaft, *y*, which passes through the table A, with a bevel-gear wheel, *a*¹, fixed to its lower end. Passing through the side of the table A and beneath the same is a shaft, L, the inner end of which has fixed to it a bevel-gear wheel, *b*¹, which meshes into the gears of the bevel-wheel *a*¹ before mentioned. The outer end of this shaft may be provided with a crank, M, or have a pulley fixed to it as a means of imparting power to the pinion K.

My sole-trimming machine being constructed substantially as I have above described, its operation is as follows: The shoe to be trimmed is placed on the last J, and the last fitted to the jack G. The arm B, with the bearing C, is placed in such a position as will bring the beveled and rounded end of the guide *m* into the channel formed between the sole and vamp. When in this position the cutting-edge of the cutter E will be in contact with the untrimmed edge of the sole, the presser F will press against the upper part of the sole, and the roller *n* will rest against the vamp of the shoe. Power, by means of the crank M or a pulley and belt, being now applied to the shaft L, the pinion K (through or by means of the turning of the bevel-wheels *a*¹ and *b*¹) revolves and forces the base H of the jack to travel or slide upon the surface of the table A until the end of the cogs on one side of the base is reached. Then the operator with his hand turns the jack until the cogs on the other side of the base are reached, when the pinion K moves it as before, and so on. As the jack travels in this manner its motion is governed by the steady-pin *v* in the slot *u* of the base H in such a manner as to bring each part of the edge of the sole of the shoe successively and continuously against the cutting-edge of the cutter E with sufficient force to cause a continuous shaving of leather to be removed from the edge of the sole as it is brought in contact with the cutter, and this operation may be repeated until the edge is properly reduced and trimmed. As the shaving is removed it passes between the edge of the cutter E and the block *k* in the same manner as does a shaving when removed by a carpenter's plane.

By omitting the cogs from the ends of the base H of the jack G, the operator is enabled to turn the toe and heel of the shoe by hand to the action of the cutter, which preserves the uniformity and smoothness of the cut at those points, which would not otherwise be the case if the jack had to be turned by the pinion and cogs around the sharp curves at the ends of the base.

As the cutter operates in the manner described, the roller *n* presses against and travels along the sides of the vamp of the shoe, and the presser F exerts a pressure on the top of the sole, keeping or preserving the relative position of the cutter against the edge of the sole, and causing a uniform thickness of cut. This is also assisted by, and the contact of the cutter against the sole maintained by, the action of the counter-weight *r*, which, by gravity, keeps the cutter and sole together, but with a yielding pressure, since the several hinged joints by which the arm B, which supports or carries the cutter, &c., is connected to the table, permit the cutter to be thrust forward or retracted, as the irregular outline of the sole requires, while at the same time the contact of the cutter against the edge of the sole is maintained; and so with the presser F. It yields a vertical pressure on the top of the sole by means of the spring *p*, so that the cutter follows the irregular shape of the edge of the sole at all times, while the guide *m* keeps in the channel between the sole and vamp, and by so doing follows all the irregularities in the side of the shoe, and regulates the thrust and cut of the cutter. The operation of the cutter is also guided by the hand of the operator, who, by turning the shaft D by a handle, *c*¹, is enabled to regulate the angle of the cutter against the edge of the sole, and he may also by this means regulate or adjust the thrust or feed independently of the action of the counter-weight *r* before named.

To assist and steady the hand of the operator while regulating the cutter by this means, the spring *i* is placed within the concavity *h* of the arm B, resting against and supporting the bearing C.

If desired, in addition to the cutter E, an additional cutter may be added, but placed below the first-mentioned one, for the purpose of more effectually trimming the edge of the sole at the shank. Such a modification is shown in Fig. 4 of the drawings, wherein *a*² represents the additional cutter, and *b*² the roller to travel along the vamp in the manner before described.

Having now described my invention, what I claim as new, and desire to secure by Letters Patent, is—

1. A machine for trimming the soles of boots and shoes, constructed with a cutter rigidly fixed to a shaft, the shaft being supported in one or more bearings, whereby it may be turned, the said bearing or bearings being pivoted to a supporting-arm which is hinged to the supporting-table of the machine, substantially as is shown and described.

2. In a machine for trimming the soles of boots and shoes, a rigidly-fixed cutter, in combination with an adjustable presser, constructed to exert a yielding pressure on the upper surface of the sole of the shoe, substantially as is herein shown and described.

3. In a machine for trimming the soles of boots and shoes, an arm, directly or indirectly

supporting and holding the cutter in position, constructed with two or more hinged joints, which secure the arm, by one of its ends, to the supporting-table of the machine, in combination with a counter-weight, whereby the thrust of the cutter against the edge of the sole of the shoe is maintained automatically, substantially as is herein shown and described.

4. In a machine for trimming the soles of boots and shoes, a revolving shaft, D, with a cutter, E, rigidly fixed to the end thereof, in combination with pivoted bearings C C, substantially as is shown and described.

5. In a machine for trimming the soles of boots and shoes, a jack or device for supporting the shoe, constructed with a base having

cogs on two of its sides, the ends of the base being without cogs, whereby the jack may be turned by hand for the purpose of trimming the toe and heel of the shoe, substantially as is hereinbefore shown and described.

6. In a machine for trimming the soles of boots and shoes, a device for holding the shoe in position, with cogs on two of its sides only, in combination with a pinion, guide-roller, steady-pin, slot, into which the steady-pin enters, gear-wheels, and driving-shaft, substantially as is herein shown and described.

CHARLES H. HELMS.

Witnesses:

H. L. WATTENBERG,
G. M. PLYMPTON.