



US 20050034204A1

(19) **United States**

(12) **Patent Application Publication** (10) **Pub. No.: US 2005/0034204 A1**

Kassai et al.

(43) **Pub. Date: Feb. 17, 2005**

(54) **CLOTHES FOR INFANT**

Aug. 9, 2001 (JP) 2001-241670

Aug. 9, 2001 (JP) 2001-241668

(76) Inventors: **Kenzou Kassai**, Osaka (JP); **Yuji Nitta**, Osaka (JP); **Tokiko Nitta**, legal representative, Osaka (JP)

Publication Classification

(51) **Int. Cl.⁷** **A41B 1/00**

(52) **U.S. Cl.** **2/69**

Correspondence Address:
Ditthavong & Carlson
Suite A
10507 Braddock Road
Fairfax, VA 22032 (US)

(57) **ABSTRACT**

In an area corresponding to, for example, the abdomen of an infant in infant clothing (1), for example, two slits (2) extending in the length direction are formed. On the back side of slit (2), a stretchable mesh material (3) is provided in a state where slit (2) is allowed to open. Preferably, tucks (5) are made on both sides of slit (2). With the configuration, the infant clothing can be used as street clothing without hesitation while having the function of an underwear, does not disturb abdominal respiration of an infant, does not become loose easily, and can excellently deal with sweat of the infant.

(21) Appl. No.: **10/416,422**

(22) PCT Filed: **Aug. 2, 2002**

(86) PCT No.: **PCT/JP02/07937**

(30) **Foreign Application Priority Data**

Aug. 9, 2001 (JP) 2001-241669

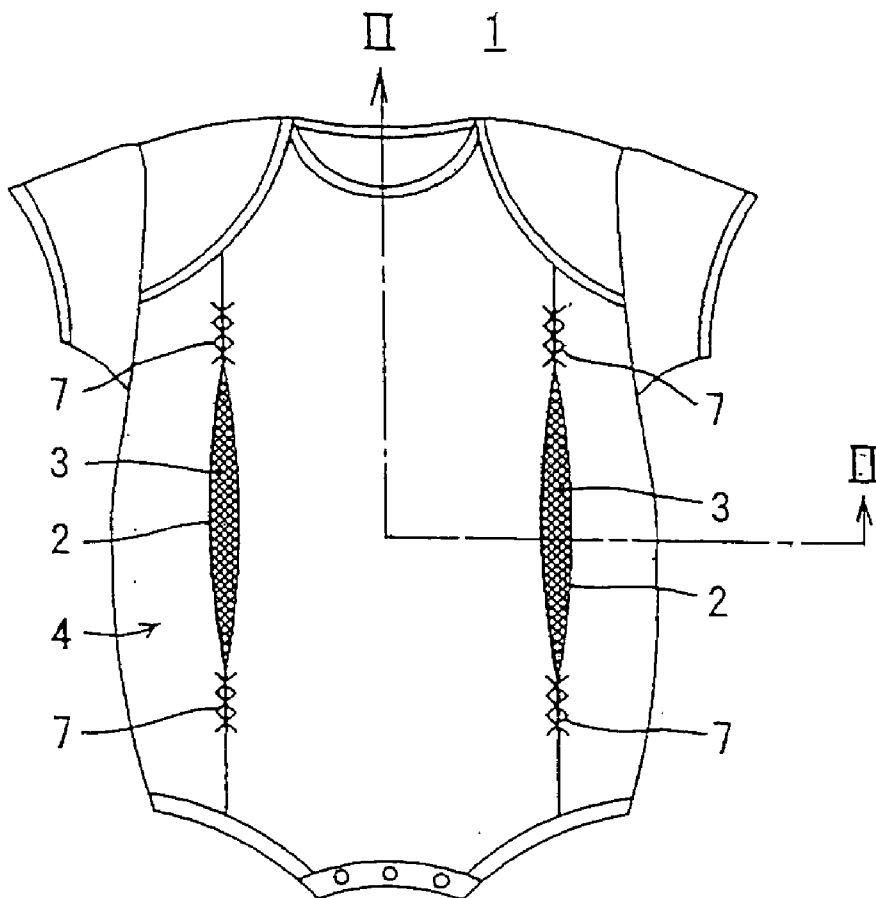

FIG. 1

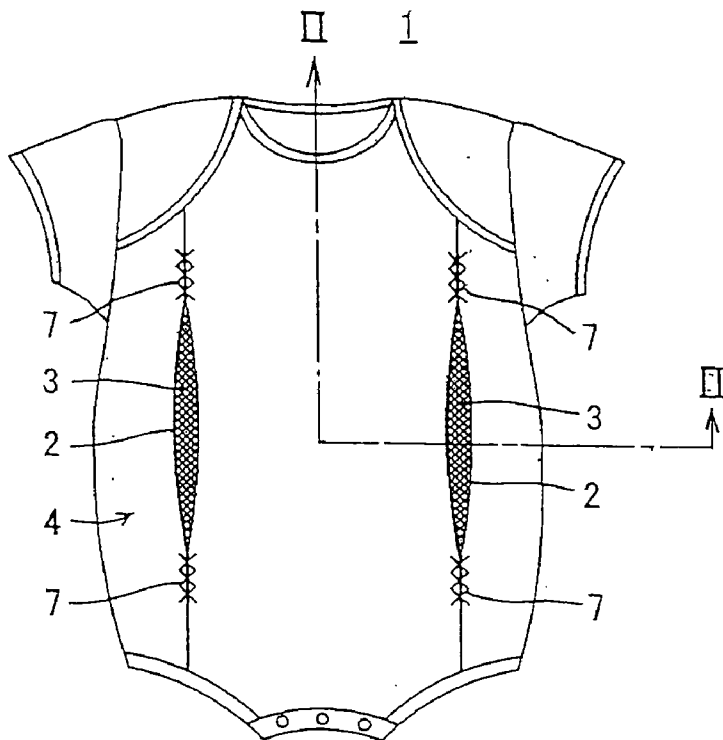

FIG. 2

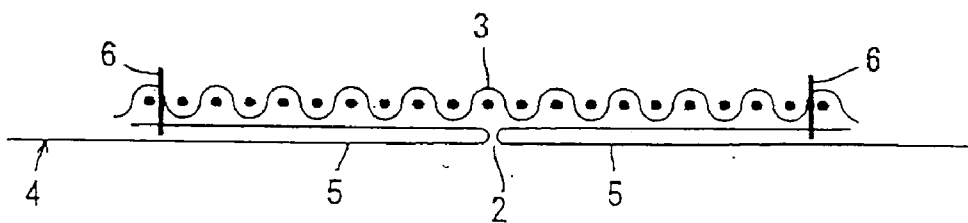

FIG.3

11

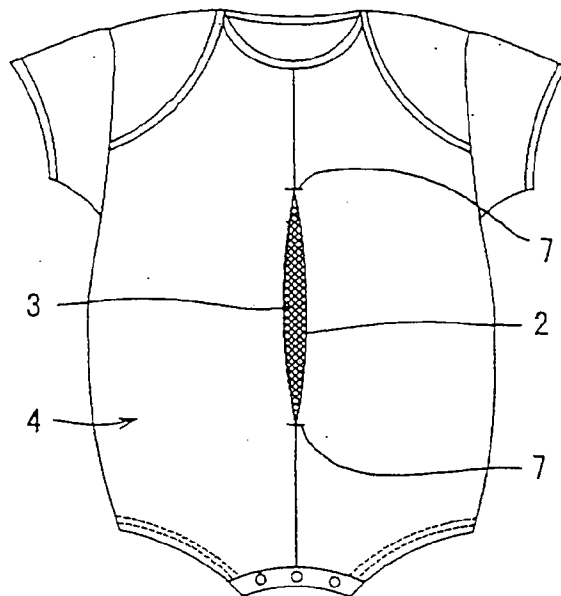

FIG.4

21

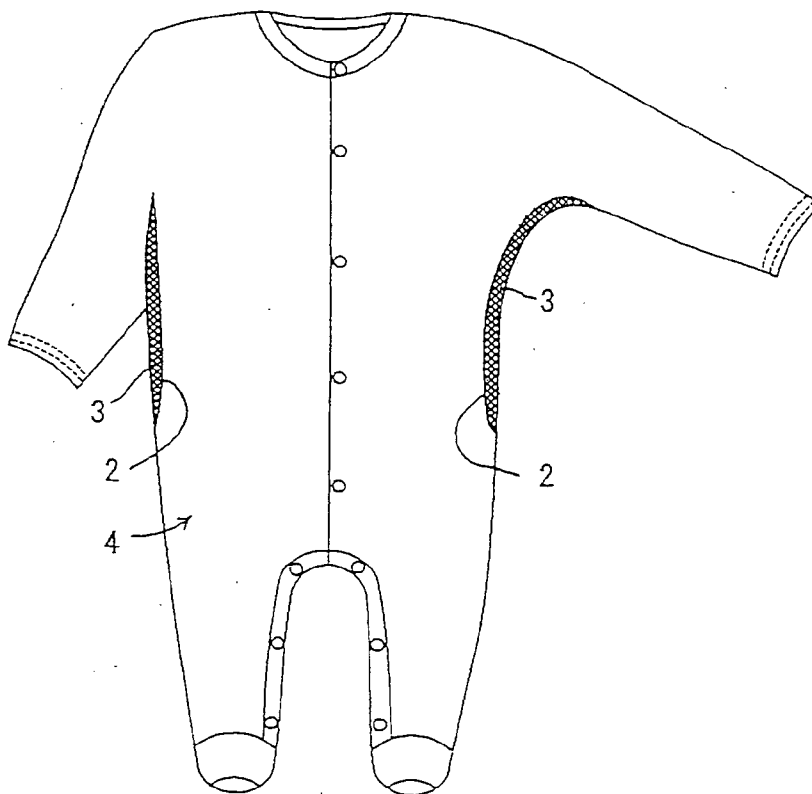

FIG.5A

30

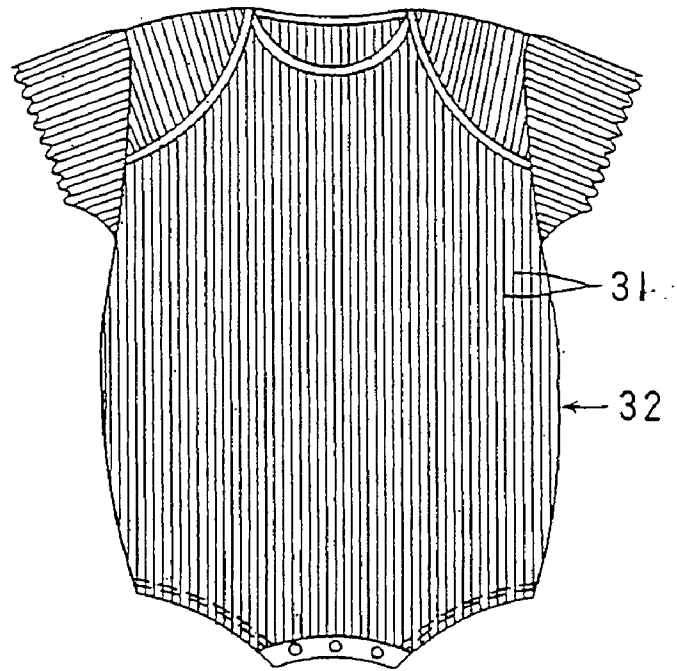

FIG.5B

30

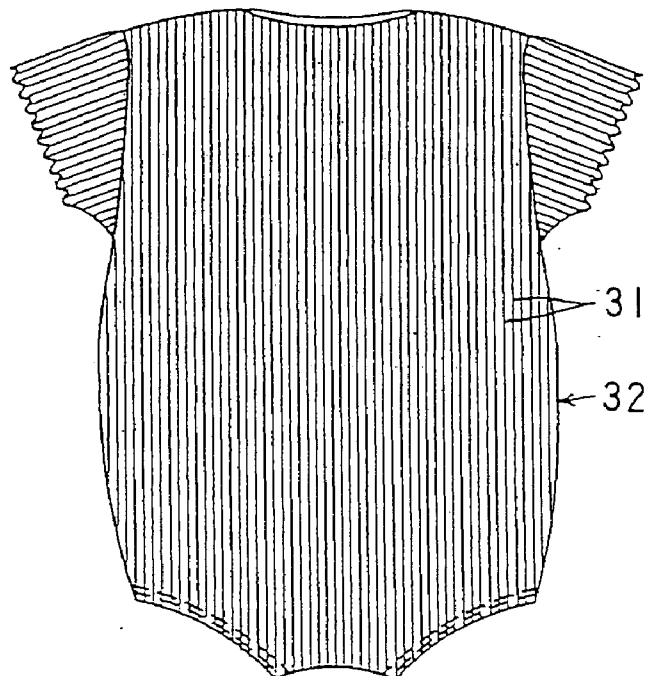

FIG. 6

40

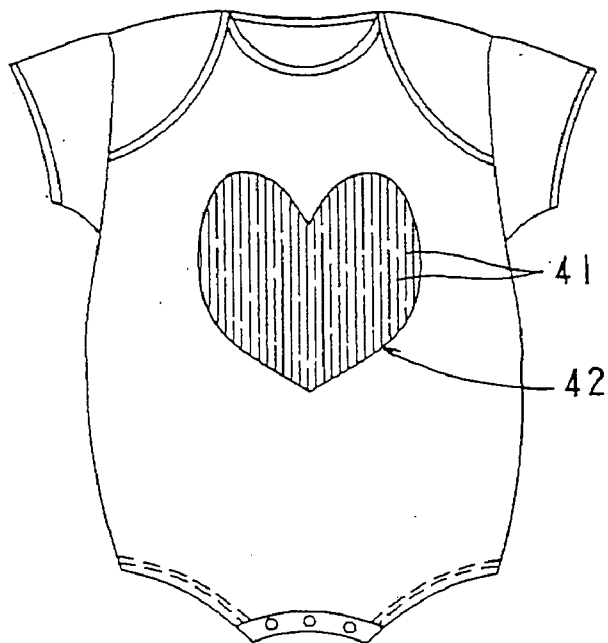

FIG. 7

50

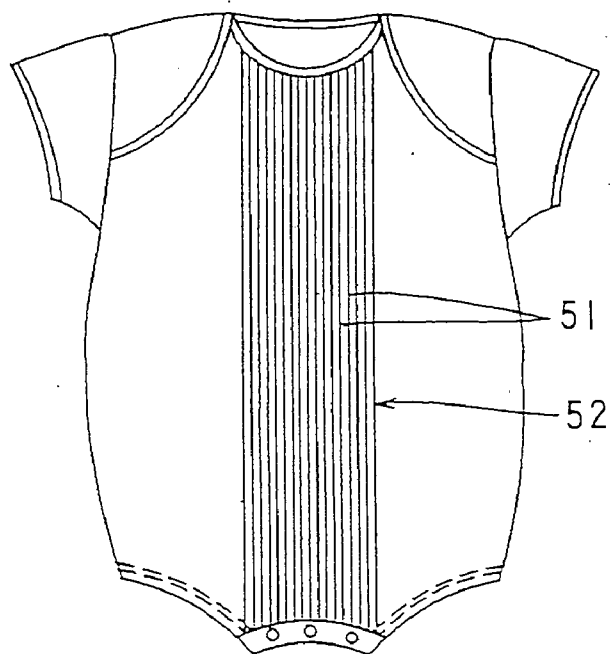

FIG. 8

60

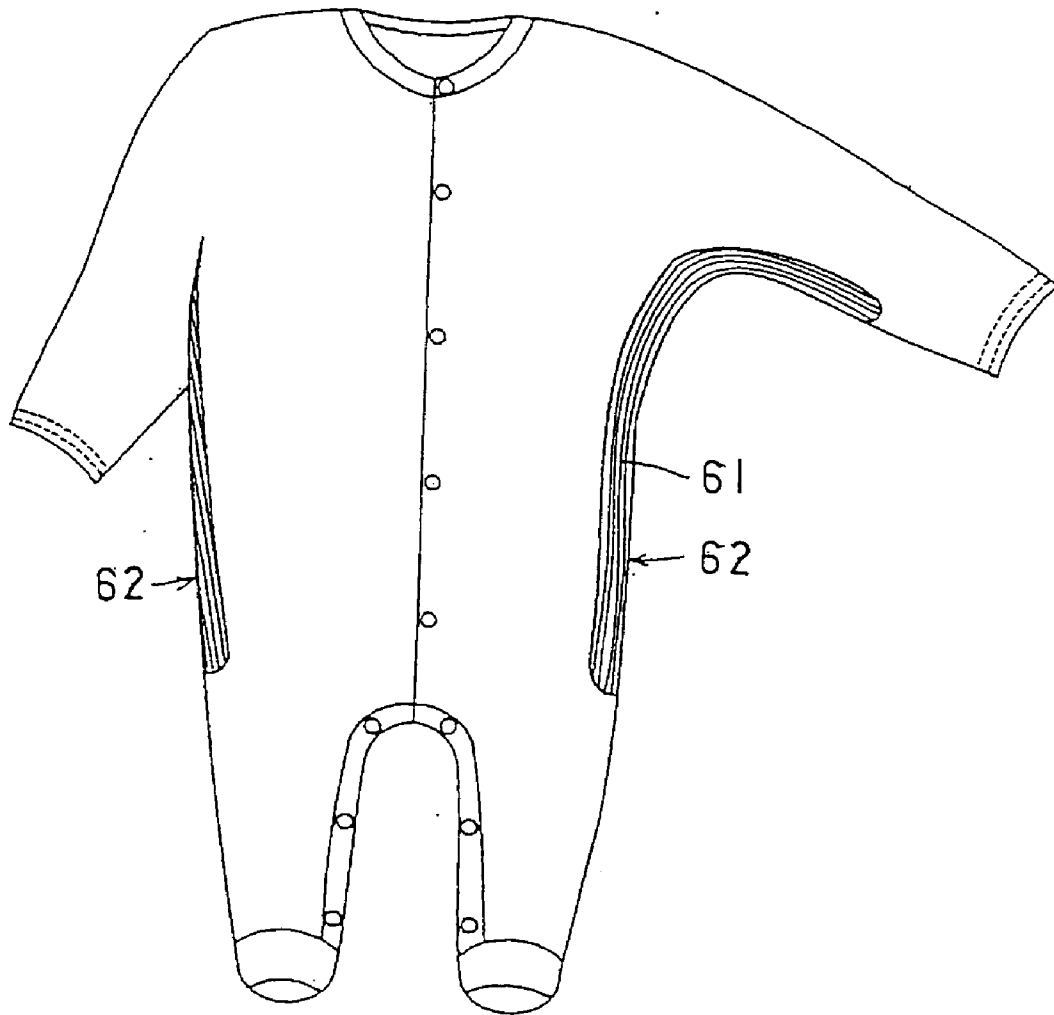

FIG.9A

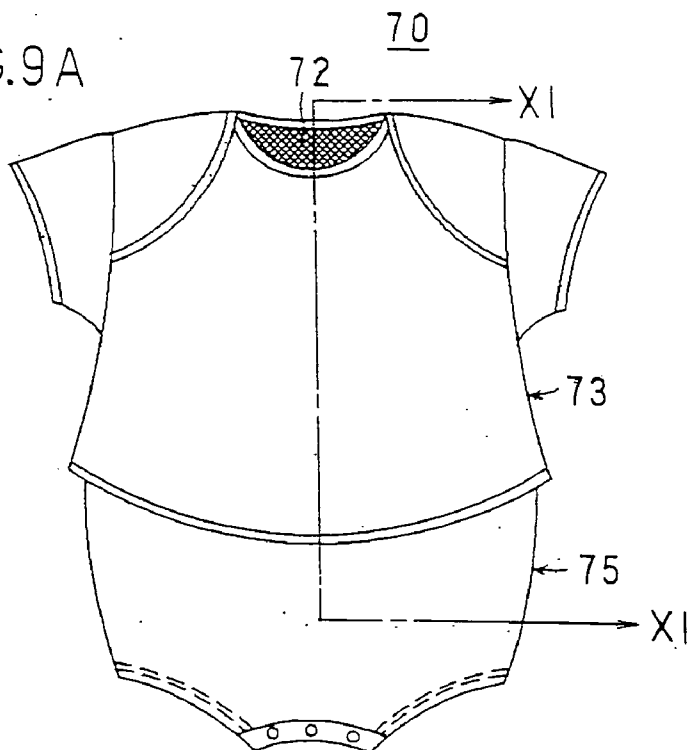

FIG.9B

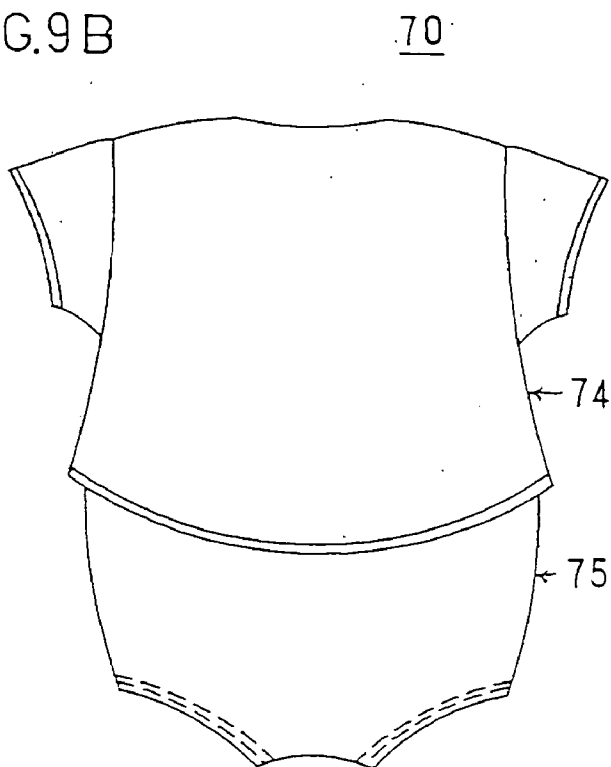

FIG.10A

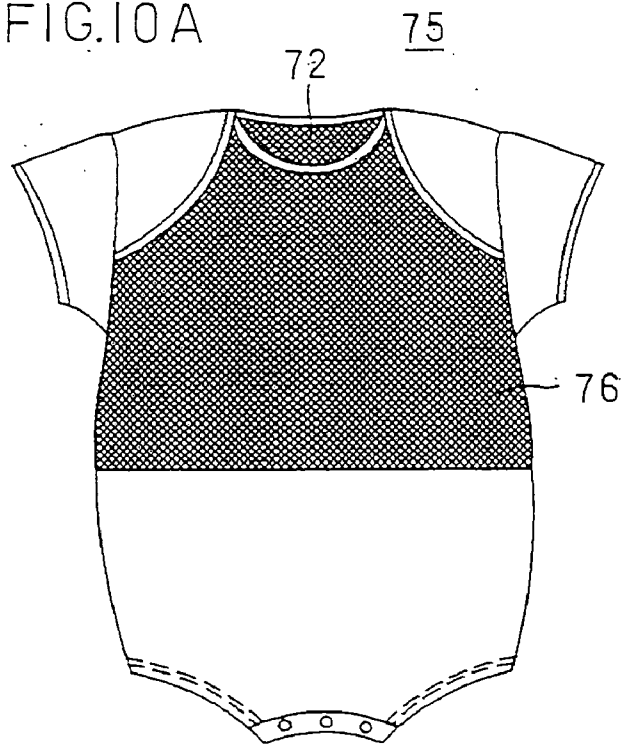

FIG.10B

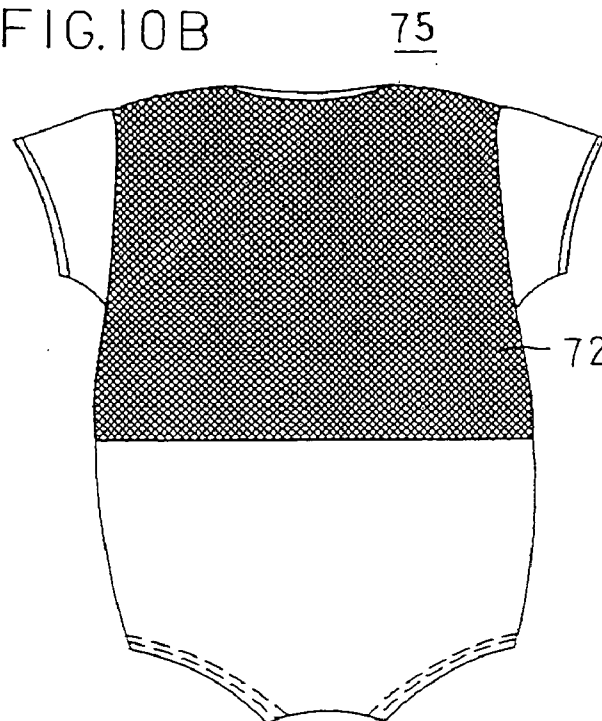

FIG. 11

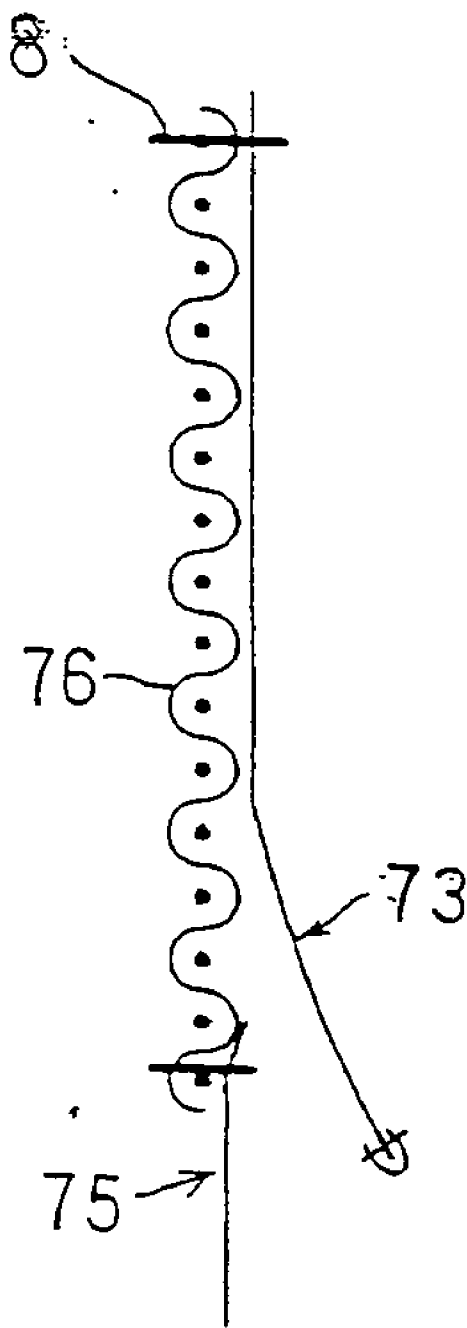

FIG. 12A

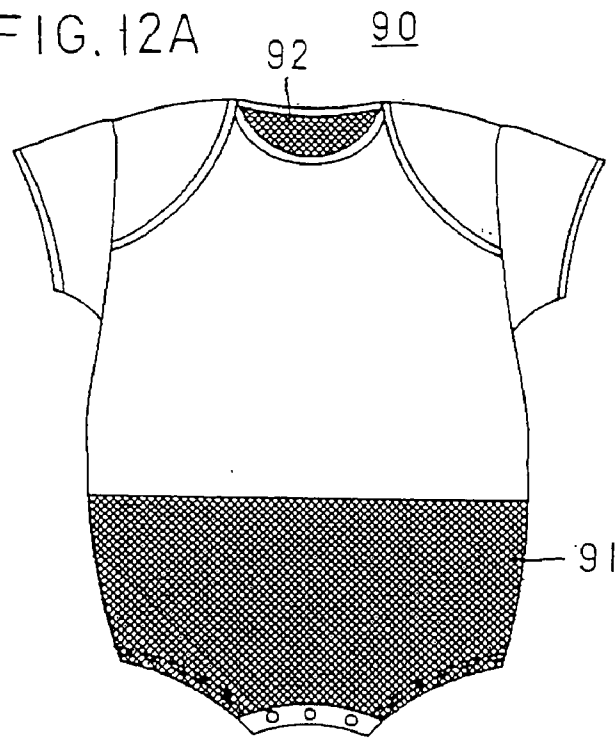
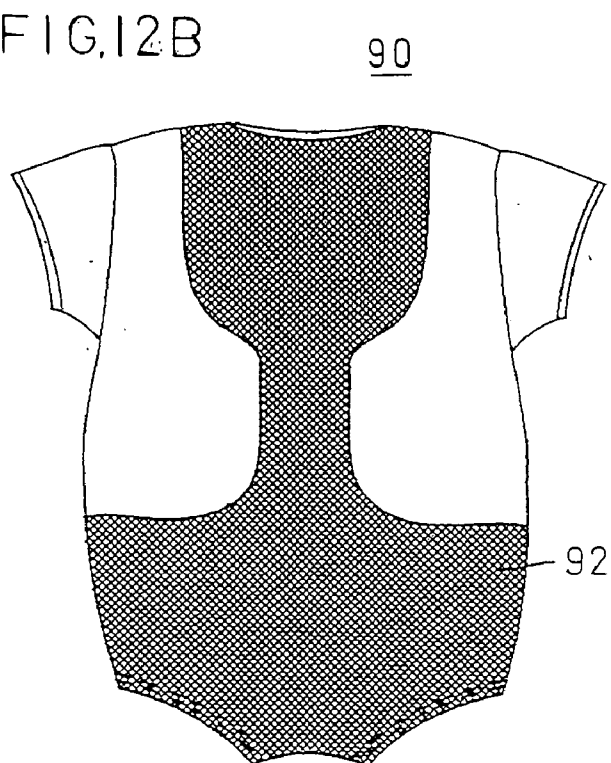
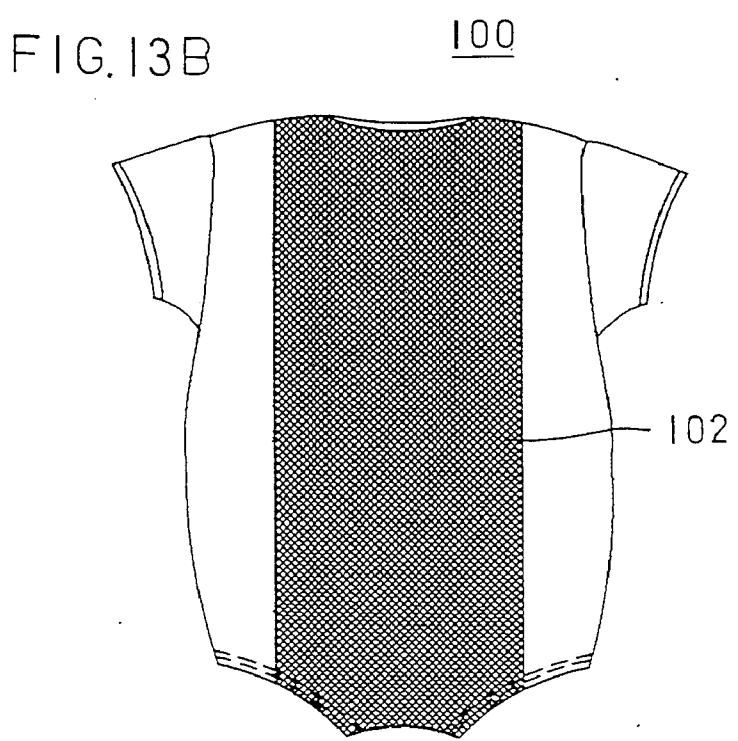
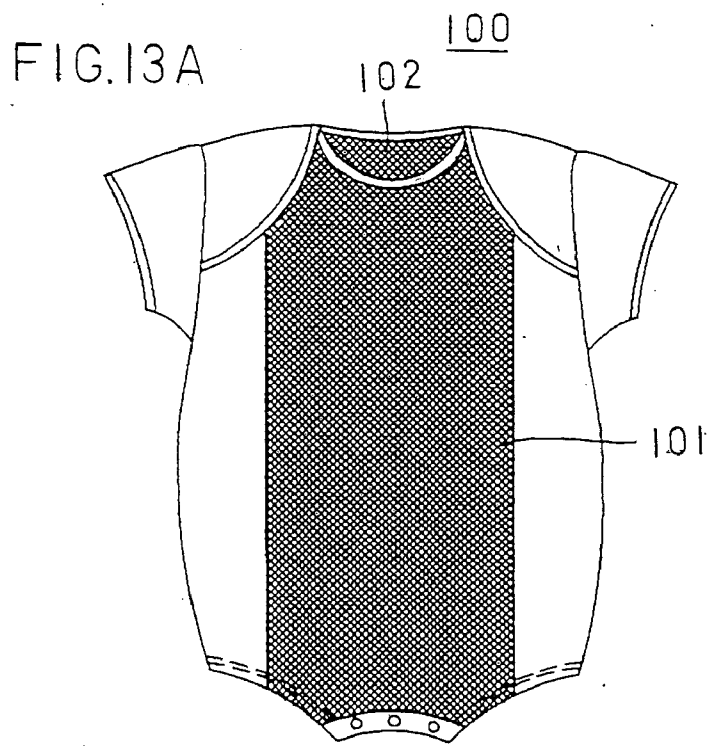

FIG. 12B





CLOTHES FOR INFANT

TECHNICAL FIELD

[0001] The present invention relates to infant clothing, and more particularly to infant clothing which can be used as street clothing while having a function of an underwear.

BACKGROUND ART

[0002] As infant clothing to be put on during infancy from a newborn to an about one year old infant, various clothing is available in the market.

[0003] Examples of such infant clothing include clothing using a material placing importance on sweat absorbency, clothing which is devised in design so as to be suitable as street clothing, and the like.

[0004] An infant lies for long time and it is no exaggeration to state that an infant moves all the time for 24 hours. Therefore, infant clothing is desired not to become loose easily but to be fit to the body to some extent under such situations.

[0005] The respiration of an infant is mainly abdominal respiration. Consequently, it is desired that infant clothing does not press the abdomen of an infant and does not disturb abdominal respiration.

[0006] Perspiration of an infant has to be also considered. Not only sweat absorbency but also appropriate permeability are required.

[0007] Further, when infant clothing can be used as street clothing without hesitation while having the function of an underwear, the clothing having excellent flexibility can be obtained.

DISCLOSURE OF THE INVENTION

[0008] An object of the present invention is, therefore, to provide infant clothing capable of satisfying the above described various demands.

[0009] Infant clothing according to the present invention is characterized in that a slit extending in the length direction is formed and a stretchable mesh material is provided on the back side of the slit in a state where the slit is allowed to open.

[0010] In the present invention, preferably, tucks are made on both sides of the slit and fabric positioned on the inside of the tuck and the mesh material are sewn together.

[0011] The slit and the mesh material provided on the back side of the slit give stretchability and permeability to the infant clothing. Therefore, the slit is formed in an area where the stretchability and permeability are preferably given. For example, it is preferable that the slit is formed in an area corresponding to the abdomen of an infant or in an area corresponding to each of sides of an infant.

[0012] Infant clothing according to another aspect of the present invention is characterized in that a part of the infant clothing is formed by pleated fabric having pleats extending in the length direction.

[0013] The pleated fabric has stretchability in the direction crossing the extending direction of the pleats and does not come into contact with the whole skin of an infant, and the

contact area is limited. Thus, the pleated fabric also has permeability. Therefore, the pleated fabric is used to form an area in which stretchability and permeability are preferably given. For example, whole infant clothing may be formed by the pleated fabric, an area corresponding to the abdomen of an infant may be formed by the pleated fabric, or areas corresponding to the sides of an infant may be formed by the pleated fabric.

[0014] Infant clothing according to still another aspect of the present invention is characterized by including: a clothing body having, as a part thereof, a mesh part made of a stretchable mesh material; and front fabric attached to the clothing body so as to cover at least the outside of the mesh part.

[0015] The mesh part has stretchability and permeability. Therefore, the mesh part is provided in an area where stretchability and permeability are preferably given. The mesh part is provided, preferably, in an area corresponding to the back of an infant, an area corresponding to the abdomen of an infant, and/or an area around a diaper of an infant, of the clothing body, for example.

[0016] In the present invention, preferably, the front fabric is attached to the clothing body in a state where the lower end of the front fabric is not joined to the clothing body.

BRIEF DESCRIPTION OF DRAWINGS

[0017] FIG. 1 is a front view showing the appearance of infant clothing 1 according to a first embodiment of the present invention;

[0018] FIG. 2 illustrates the cross section taken along line II-II of FIG. 1;

[0019] FIG. 3 is a front view showing the appearance of infant clothing 11 according to a second embodiment of the present invention;

[0020] FIG. 4 is a front view showing the appearance of infant clothing 21 according to a third embodiment of the present invention;

[0021] FIGS. 5A and 5B show the appearance of infant clothing 30 according to a fourth embodiment of the present invention, FIG. 5A is a front view and FIG. 5B is a rear view;

[0022] FIG. 6 is a front view showing the appearance of infant clothing 40 according to a fifth embodiment of the present invention;

[0023] FIG. 7 is a front view showing the appearance of infant clothing 50 according to a sixth embodiment of the present invention;

[0024] FIG. 8 is a front view showing the appearance of infant clothing 60 according to a seventh embodiment of the present invention;

[0025] FIGS. 9A and 9B show the appearance of infant clothing 70 according to an eighth embodiment of the present invention, FIG. 9A is a front view and FIG. 9B is a rear view;

[0026] FIGS. 10A and 10B show states where front fabrics 73 and 74 are removed from infant clothing 70 shown in FIGS. 9A and 9B, FIG. 10A is a front view and FIG. 10B is a rear view;

[0027] FIG. 11 illustrates the cross section taken along line XI-XI of FIG. 9A;

[0028] FIGS. 12A and 12B are views corresponding to FIGS. 10A and 10B, for describing a ninth embodiment of the present invention; and

[0029] FIGS. 13A and 13B are views corresponding to FIGS. 10A and 10B, for describing a tenth embodiment of the present invention.

BEST MODE FOR CARRYING OUT THE INVENTION

[0030] FIGS. 1 and 2 are used to describe a first embodiment of the present invention. FIG. 1 is a front view showing the appearance of infant clothing 1 and FIG. 2 illustrates the cross section taken along line II-II of FIG. 1.

[0031] In an area corresponding to the abdomen of an infant of infant clothing 1, two slits 2 extending in the length direction are formed. On the rear side of each of slits 2, a stretchable mesh material 3 is provided in a state where slit 2 is allowed to open.

[0032] More particularly, as well shown in FIG. 2, fabric 4 of infant clothing 1 is folded back so as to make tucks 5 on both sides of each of slits 2, and a portion positioned on the inside of each of tucks 5 in fabric 4 and mesh material 3 are sewn together by, for example, sewing thread 6.

[0033] The portions positioned on both ends in the longitudinal direction of each of slits 2 in fabric 4 are sewn by sewing thread 7. At least a part of sewing thread 7, embroidery thread may be used, which accents the design.

[0034] Mesh material 3 may employ any knitting structure or weave structure as long as it provides stretchability and permeability. Mesh material 3 is preferably a fiber material having sweat absorbency.

[0035] Since infant clothing 1 has the function of an underwear, it is preferable to employ gauge sewing so that stitches formed by sewing do not come into direct contact with the skin of the infant.

[0036] According to the embodiment, two slits 2 extending in the length direction are formed, mesh material 3 is provided in a state where slits 2 are allowed to open, and mesh material 3 has stretchability. Consequently, the abdomen of an infant is not pressed and abdominal respiration of the infant is not disturbed, and yet infant clothing 1 can be fit to the body of the infant to some extent. Even when infant clothing 1 is put on an infant moving all the time for 24 hours, it does not become loose easily. Because of permeability given by slits 2 and mesh material 3, the infant can be prevented from feeling uncomfortable due to sweat.

[0037] Since mesh material 3 is disposed on the back side of slit 2, mesh material 3 is not seen conspicuously from the outside. Consequently, infant clothing 1 can be also used as street clothing without any hesitation.

[0038] FIG. 3 is a front view showing the appearance of infant clothing 11 according to a second embodiment of the present invention. In FIG. 3, elements corresponding to the elements shown in FIG. 1 are designated by the same reference numerals and their description will not be repeated.

[0039] In infant clothing 11 shown in FIG. 3, one slit 2 extending in the length direction is formed in the center of an area corresponding to the abdomen of an infant. On the back side of slit 2, stretchable mesh material 3 is provided in a state where slit 2 is allowed to open.

[0040] In the embodiment as well, in a mode as shown in FIG. 2, slit 2 is formed and mesh material 3 is attached.

[0041] By the embodiment as well, effects substantially the same as those of the first embodiment are achieved.

[0042] FIG. 4 is a front view showing the appearance of infant clothing 21 according to a third embodiment of the present invention. In FIG. 4, elements corresponding to the elements shown in FIG. 1 are designated by the same reference numerals and their description will not be repeated.

[0043] Although the general shape of infant clothing 21 shown in FIG. 4 is different from that of each of infant clothing 1 and 11 shown in FIGS. 1 and 3, the difference is not an essential difference.

[0044] In infant clothing 21 shown in FIG. 4, slits 2 extending in the length direction are formed in areas corresponding to the sides of an infant. On the back side of each of slits 2, stretchable mesh material 3 is provided in a state where slit 2 is allowed to open. In the embodiment as well, in a mode as shown in FIG. 2, slits 2 are formed and mesh material 3 is attached.

[0045] By the embodiment as well, effects substantially the same as those of the first and second embodiments are achieved. Particularly, according to the third embodiment, stretchability and permeability can be provided in the portions of the sides of an infant.

[0046] Although the present invention has been described above in relation to the embodiments shown in the drawings, the present invention can be variously modified within the scope of the present invention.

[0047] For example, the design of the whole infant clothing, positions in which the slits are formed, sewing and processing methods for forming a slit, a mode of providing a mesh material in relation to a slit, and the like can be arbitrarily changed as necessary.

[0048] As described above, according to the present invention, a slit extending in the length direction is formed while a stretchable mesh material is provided on the back side of the slit in a state where the slit is allowed to open. Thus, in addition to permeability, stretchability in the direction orthogonal to the length direction can be provided for the infant clothing.

[0049] FIGS. 5A and 5B show the appearance of infant clothing 30 according to a fourth embodiment of the present invention. FIG. 5A is a front view and FIG. 5B is a rear view.

[0050] Whole infant clothing 30 is formed by pleated fabric 32 having pleats 31 extending in the length direction. Since pleated fabric 32 has stretchability in the direction crossing the extending direction of pleats 31, the abdomen of an infant is not pressed and abdominal respiration is not disturbed. Infant clothing 30 can be fit to the body of an infant to some extent because of the stretchable property of pleated fabric 32. Consequently, even when the clothing is

put on an infant who moves all the time for 24 hours, the clothing does not become loose easily.

[0051] Pleated fabric 32 is not in contact with the entire skin of an infant and a contact area is limited, so that permeability can be given. Therefore, the infant can be prevented from feeling uncomfortable due to sweat.

[0052] Pleated fabric 32 used for infant clothing 30 is preferably made of a fiber material having sweat absorbency.

[0053] Since infant clothing 30 has the function of an underwear, it is preferable to employ gauge sewing so that stitches formed by sewing do not come into direct contact with the skin of an infant.

[0054] FIG. 6 is a front view showing the appearance of infant clothing 40 according to a fifth embodiment of the present invention.

[0055] A part of infant clothing 40 shown in FIG. 6 is formed by pleated fabric 42 having pleats 41 extending in the length direction. As pleated fabric 42, for example, fabric in which random pleats are formed is used.

[0056] More particularly, in the embodiment, an area corresponding to the abdomen of an infant is formed by pleated fabric 42. Pleated fabric 42 has the shape of a heart which accents the design.

[0057] On the back side of pleated fabric 42, any fabric does not exist.

[0058] According to the embodiment, particularly in the portion of the abdomen of an infant, stretchability and permeability are given by using pleated fabric 42.

[0059] FIG. 7 is a front view showing the appearance of infant clothing 50 according to a sixth embodiment of the present invention.

[0060] Also in infant clothing 50 shown in FIG. 7, a part thereof is formed by pleated fabric 52 having pleats 51 extending in the length direction.

[0061] Particularly, in the embodiment, the area corresponding to the abdomen of an infant is formed by pleated fabric 52, and pleated fabric 52 extends from the upper end of infant clothing 50 to the lower end.

[0062] No other fabric exists on the back side of pleated fabric 52.

[0063] By the embodiment as well, stretchability and permeability can be given by pleated fabric 52 in the portion of the abdomen of an infant.

[0064] FIG. 8 is a front view showing the appearance of infant clothing 60 according to a seventh embodiment of the present invention.

[0065] Although infant clothing 60 shown in FIG. 8 has a general shape different from any of infant clothing 30, 40 and 50 shown in FIGS. 5A to 7, the difference is not an essential difference.

[0066] Also in infant clothing 60 shown in FIG. 8, a part thereof is formed by pleated fabric 62 having pleats 61 extending in the length direction. The areas corresponding to the sides of an infant are formed by pleated fabric 62.

[0067] According to the embodiment, in the portions of the sides of an infant, stretchability and permeability by pleated fabric 62 can be given.

[0068] Although the present invention has been described above in relation to the embodiments illustrated, the present invention can be variously modified within the scope of the present invention.

[0069] For example, the design of the whole infant clothing, an area formed by the pleated fabric, and the like can be arbitrarily changed as necessary.

[0070] As described above, according to the embodiment of the present invention, at least a part of infant clothing is formed by pleated fabric having pleats extending in the length direction. Consequently, because of stretchability and permeability of the pleated fabric, the abdominal respiration of an infant is not disturbed and the infant clothing does not become loose easily. Further, the infant can be prevented from feeling uncomfortable due to sweat.

[0071] According to the present invention, the design can be easily changed by using pleated fabric. Thus, infant clothing can be also used as street clothing without hesitation while it is used as an underwear.

[0072] FIGS. 9A to 11 are views for describing an eighth embodiment of the present invention. FIG. 9A is a front view of the appearance of infant clothing 70, and FIG. 9B is a rear view of the appearance. FIG. 10A is a front view showing a state where front fabric is removed from infant clothing 70 shown in FIGS. 9A and 9B, and FIG. 10B is a rear view. FIG. 11 illustrates the cross section taken along line XI-XI of FIG. 9A.

[0073] Infant clothing 70 has a clothing body 75 of which general form is well shown in FIGS. 10A and 10B. A part of clothing body 75 is formed by mesh parts 72 and 76 made of a stretchable mesh material. In the embodiment, one mesh part 76 is provided in the area corresponding to the abdomen of an infant and the other mesh part 72 is provided in the area corresponding to the back of an infant.

[0074] The mesh material constructing mesh parts 76 and 72 may have any knitting structure or weave structure as long as it provides stretchability and permeability. The mesh material is, preferably, a fiber material having sweat absorbency.

[0075] Since mesh parts 76 and 72 have stretchability, the abdomen of an infant is not pressed and, therefore, abdominal respiration of an infant is not disturbed. In addition, mesh parts 76 and 72 enable the clothing body 75 to be fit to the body of an infant to certain extent. Consequently, even when the clothing is put on an infant who moves all the time for 24 hours, the clothing does not become loose easily. Because of permeability of mesh parts 76 and 72, the infant can be prevented from feeling uncomfortable due to sweat.

[0076] Infant clothing 70 has front fabrics 73 and 74 attached to clothing body 75 so as to cover at least the outer sides of mesh parts 76 and 72 as well shown in FIG. 9A. Infant clothing 70 has inherently the function of an underwear but, by having front fabrics 73 and 74, infant clothing 70 can be also used as street clothing without hesitation. By changing the design of infant clothing 70 with front fabrics 73 and 74 and properly selecting the shape, color and the like of front fabrics 73 and 74, infant clothing 70 can be variously designed.

[0077] Front fabrics **73** and **74** are preferably attached to clothing body **75** in a state where the lower end of front fabric **73** is not joined to clothing body **75** as shown in **FIG. 11**. By employing such a configuration, front fabrics **73** and **74** can be attached in a state where permeability of mesh parts **76** and **72** is not disturbed so much. By sewing front fabrics **73** and **74** to the upper end with sewing thread **8**, when an infant wears the clothing, the shape of each of front fabrics **73** and **74** can be made stable.

[0078] Front fabric **73** may be sewn with front fabric **74** at each of sides so that front fabrics **73** and **74** form an integral cylinder shape.

[0079] Since infant clothing **70** has the function of an underwear, it is preferable to employ gauge sewing so that stitches formed by the sewing do not come direct contact with the skin of an infant.

[0080] **FIGS. 12A and 12B** are views corresponding to **FIGS. 10A and 10B** for describing a ninth embodiment of the present invention.

[0081] Therefore, only a clothing body **90** is shown in **FIGS. 12A and 12B**, and the front fabrics are not illustrated.

[0082] Clothing body **90** has a mesh part **91** provided in an area on the front body side around a diaper of an infant, and a mesh part **92** provided in a range from the area of the back body side around the diaper of the infant to the back.

[0083] According to the embodiment, permeability of not only the back of an infant but also the area around a diaper can be increased. By the embodiment as well, effects such that abdominal respiration of an infant is not disturbed and the clothing does not become loose easily are achieved.

[0084] **FIGS. 13A and 13B** are views corresponding to **FIGS. 10A and 10B** for describing a tenth embodiment of the present invention. Therefore, **FIGS. 13A and 13B** show only clothing body **100** and front fabrics are not illustrated.

[0085] In the embodiment, a mesh part **101** is provided in an area corresponding to the abdomen of an infant, and a mesh part **102** is provided in an area corresponding to the back, of clothing body **100**. Each of mesh parts **101** and **102** extends in a wide stripe shape from the upper end of clothing body **100** to the lower end, that is, from the area around the neck to the area around a diaper.

[0086] According to the embodiment, when not-shown fabrics are attached to clothing body **100** so as to cover mesh parts **101** and **102**, the design of stripes in the vertical direction can be given by the front fabrics.

[0087] According to the embodiment as well, effects such that abdominal respiration is not disturbed, the clothing does not become loose easily, and excellent permeability can be given to the abdomen and the back of an infant and around a diaper are achieved.

[0088] Although the present invention has been described above in relation to the above described embodiments, the present invention can be variously modified within the scope of the present invention.

[0089] For example, the design of the whole infant clothing, areas in which the mesh parts are provided, and the like can be arbitrarily changed as necessary.

[0090] As described above, according to the present invention, a mesh part made of a stretchable mesh material is provided in a part of the clothing body. Consequently, because of stretchability and permeability of the mesh part, abdominal respiration of an infant is not disturbed, the clothing does not become loose easily and, further, an infant can be prevented from feeling uncomfortable due to sweat.

[0091] According to the present invention, front fabrics are attached to the clothing body so as to cover at least the outer side of the mesh part, so that while the infant clothing is used as an underwear, it can be also used as street clothing without hesitation. By devising the shape, color and the like of the front fabric, the design of the infant clothing can be easily changed.

[0092] With respect to the attachment state of the front fabric, when the front fabric is attached to the clothing body in a state where the lower end of the front fabric is not joined to the clothing body, the permeability of the mesh part is not disturbed so much by the front fabric. By sewing the front fabric at the upper end, when an infant wears the clothing, the shape of the front fabric can be made stable.

INDUSTRIAL APPLICABILITY

[0093] As described above, according to the present invention, it is possible to realize infant clothing which can be used as street clothing without hesitation while having the function of an underwear, does not disturb abdominal respiration of an infant, does not become loose easily and, further, excellently deals with sweat of an infant.

1. Infant clothing, wherein a slit (**2**) extending in the length direction is formed and a stretchable mesh material (**3**) is provided on the back side of said slit in a state where said slit is allowed to open.

2. The infant clothing according to claim 1, wherein tucks (**5**) are made on both sides of said slit (**2**) and fabric positioned on the inside of said tuck and said mesh material are sewn together.

3. The infant clothing according to claim 1, wherein said slit (**2**) is formed in an area corresponding to the abdomen of an infant.

4. The infant clothing according to claim 1, wherein said slit (**2**) is formed in an area corresponding to each of sides of an infant.

5. Infant clothing, wherein at least a part thereof is formed by pleated fabric (**32**) having pleats (**31**) extending in the length direction.

6. The infant clothing according to claim 5, wherein the whole infant clothing is formed by said pleated fabric.

7. The infant clothing according to claim 5, wherein an area corresponding to the abdomen of an infant is formed by said pleated fabrics (**42, 52**).

8. The infant clothing according to claim 5, wherein areas corresponding to the sides of an infant are formed by said pleated fabric (**62**).

9. Infant clothing comprising: a clothing body having, as a part thereof, a mesh part (**72, 76, 91, 92**) made of a stretchable mesh material; and front fabric (**73, 74**) attached to said clothing body so as to cover at least the outside of said mesh part.

10. The infant clothing according to claim 9, wherein said mesh part is provided in an area corresponding to the back of an infant, of said clothing body.

11. The infant clothing according to claim 9, wherein said mesh part (**101**) is provided in an area corresponding to the abdomen of an infant, of said clothing body.

12. The infant clothing according to claim 9, wherein said mesh part (**91, 92**) is provided in an area around a diaper of an infant, of said clothing body.

13. The infant clothing according to claim 9, wherein said front fabric is attached to said clothing body in a state where the lower end of said front fabric is not joined to said clothing body.

* * * * *