



US 20060001015A1

(19) **United States**

(12) **Patent Application Publication**
Forbis et al.

(10) **Pub. No.: US 2006/0001015 A1**

(43) **Pub. Date: Jan. 5, 2006**

(54) **METHOD OF FORMING A BARRIER**

Publication Classification

(75) Inventors: **John T. Forbis**, Lincoln, NE (US); **Roy H. Kaltenbach**, York, NE (US)

(51) **Int. Cl.**
E04H 17/14 (2006.01)

(52) **U.S. Cl.** **256/59**

Correspondence Address:

KARL R CANNON
PO BOX 1909
SANDY, UT 84091 (US)

(57) **ABSTRACT**

(73) Assignee: **Kroy Building Products, Inc. ;**

A rail is disclosed for use in forming a barrier system, such as a railing for a deck, porch, walkway or fence. The rail has a versatile configuration in that either a top or bottom side of the rail may be received in a rail cover. The rail may have side walls and a cross wall on the top or bottom side of the rail. A channel may be formed on the side of the rail opposite the cross wall. Upright members, such as pickets, planks, balusters, or walls may be received in either the top side or the bottom side of the rail, in the channel or through the cross wall. A cap having openings for receiving the upright member may be placed on the channel. The rail may be positioned on the top or bottom of the barrier system and the rail may be symmetrical to provide an aesthetically pleasing appearance.

(21) Appl. No.: **11/124,605**

(22) Filed: **May 5, 2005**

Related U.S. Application Data

(60) Division of application No. 10/931,287, filed on Aug. 30, 2004, which is a continuation-in-part of application No. 10/764,333, filed on Jan. 23, 2004, now abandoned.

(60) Provisional application No. 60/473,535, filed on May 26, 2003.

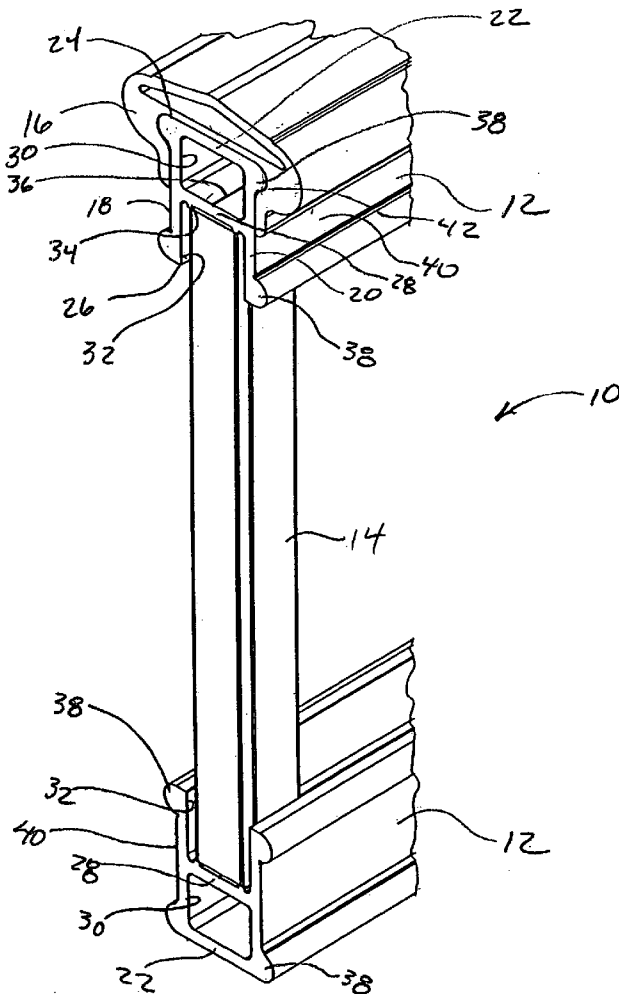

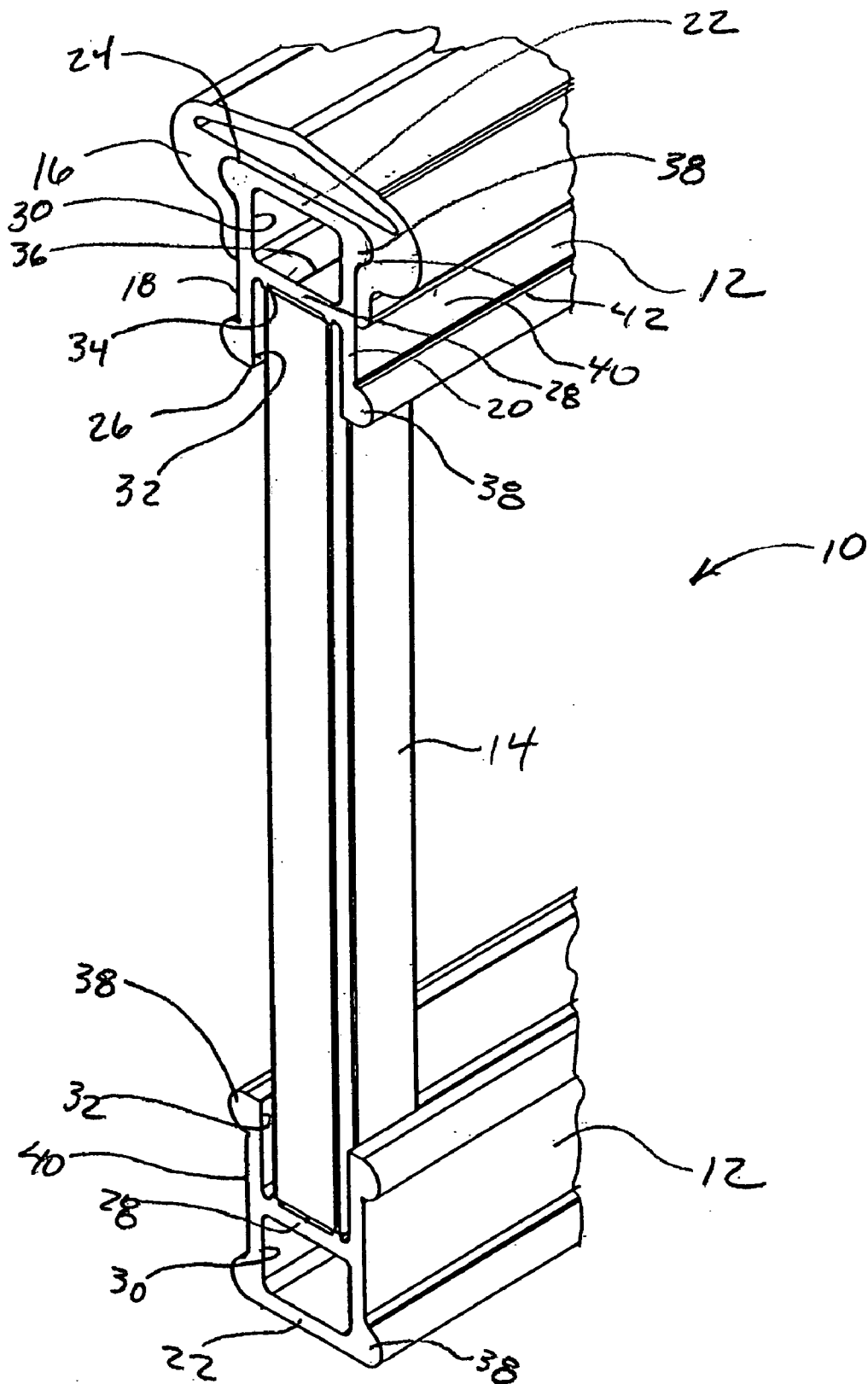

FIG. 1

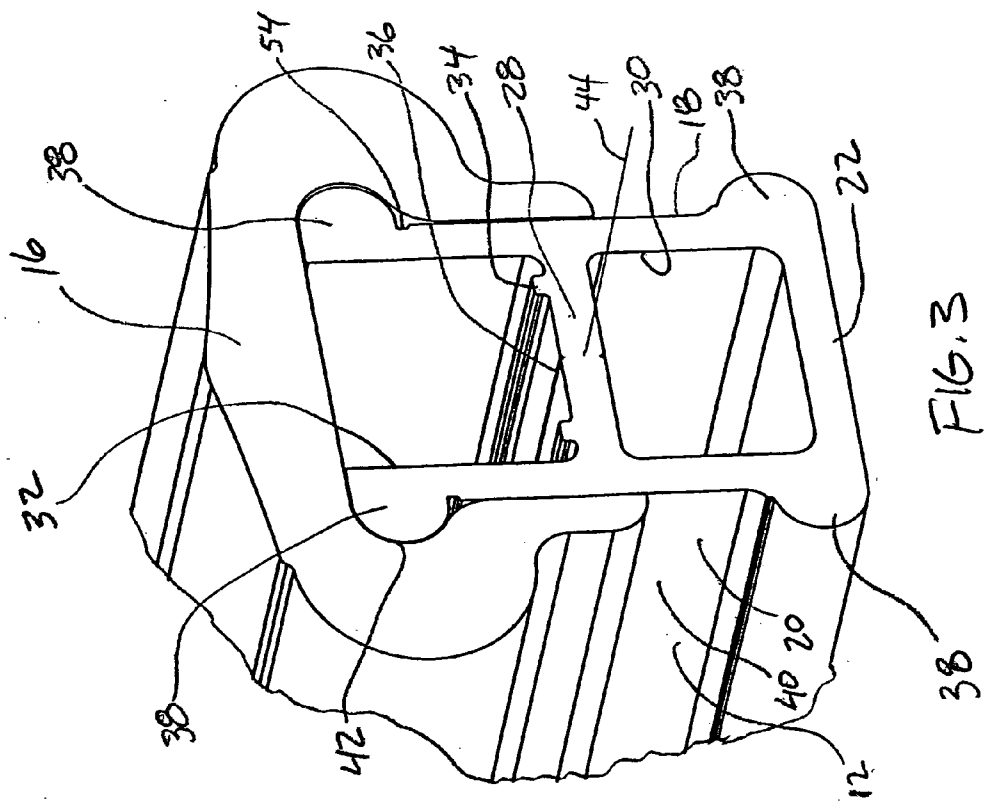

FIG. 3

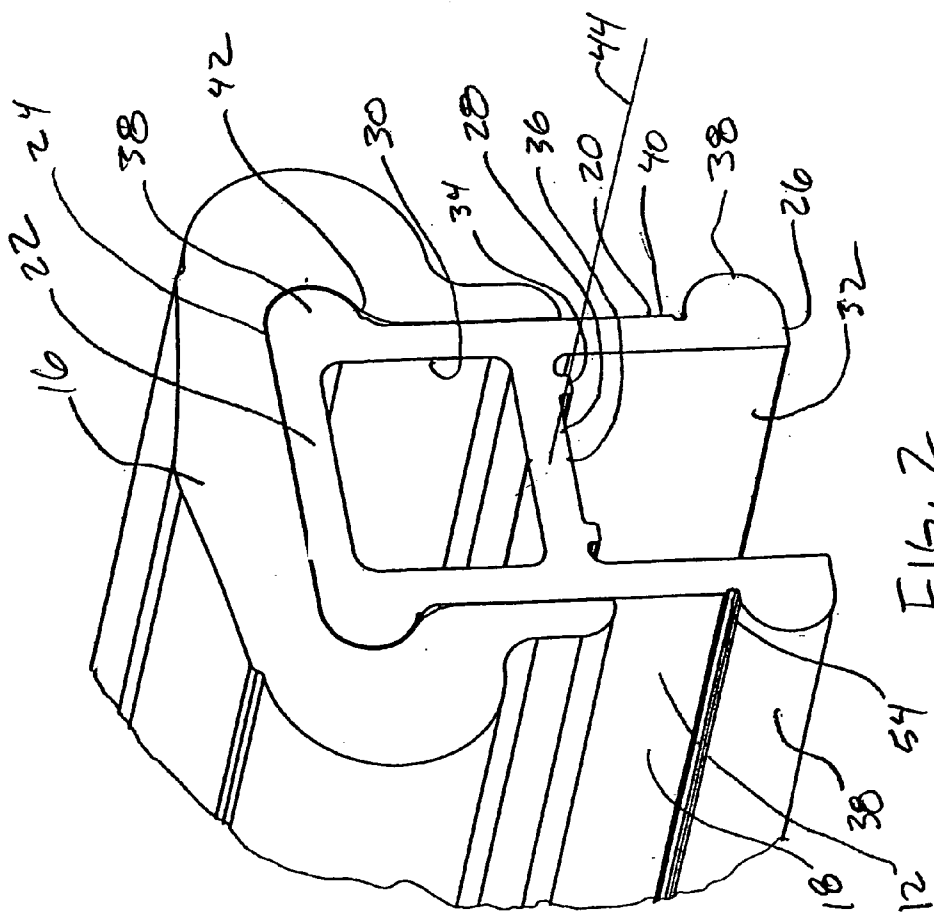
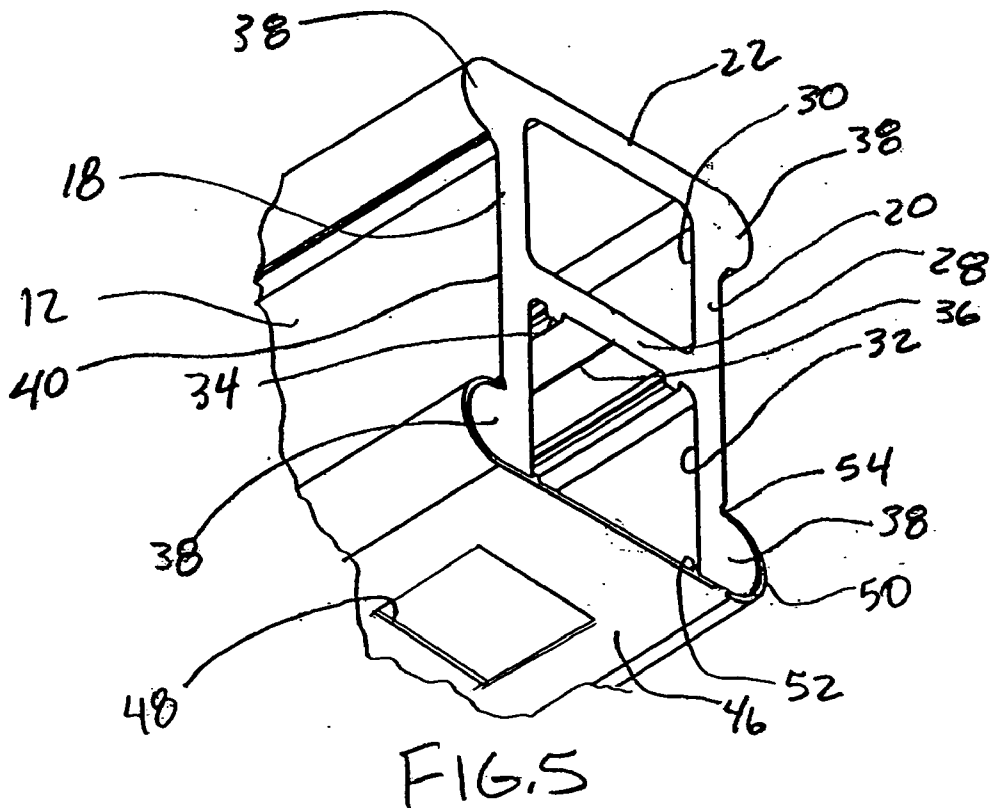
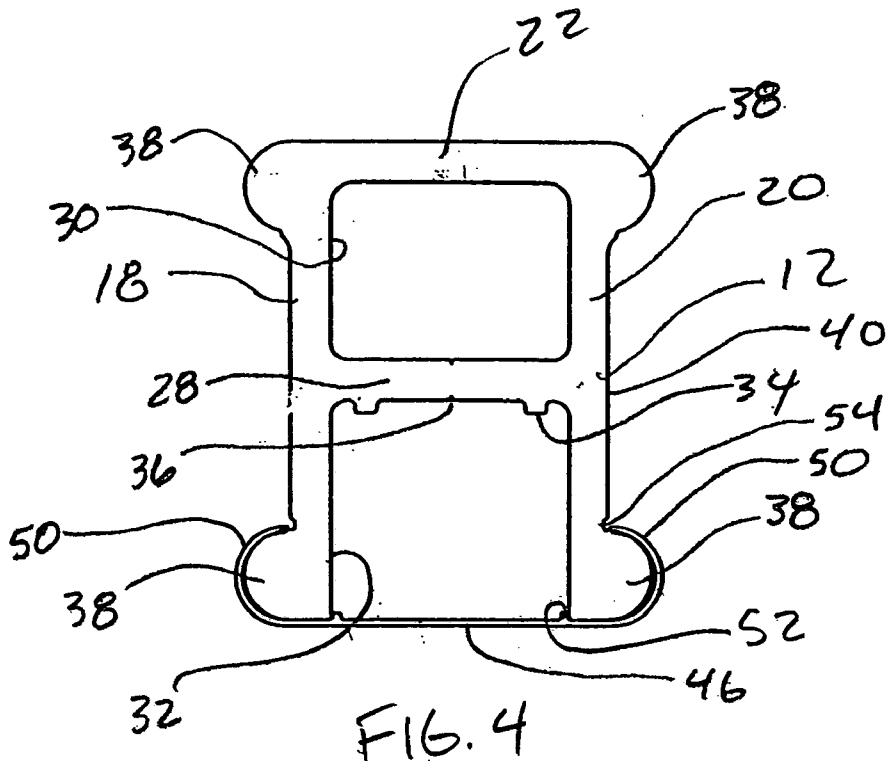

FIG. 2



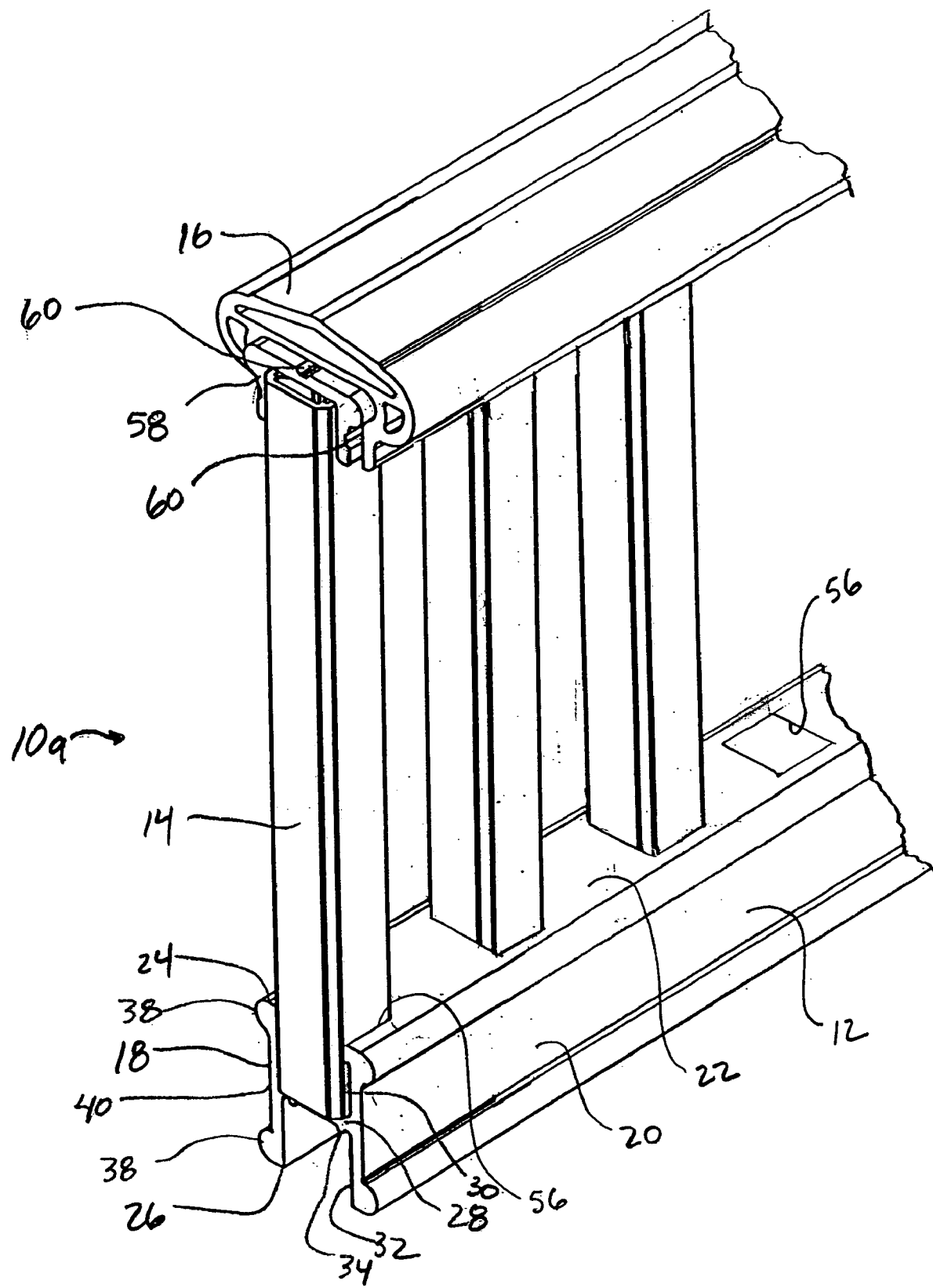

FIG. 6

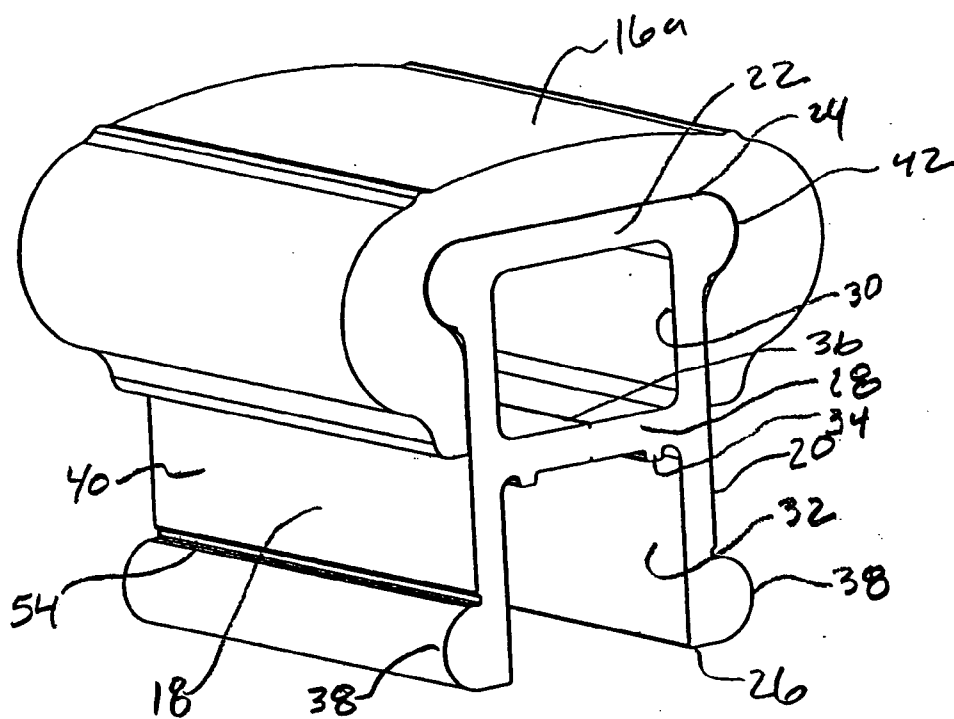

FIG. 7

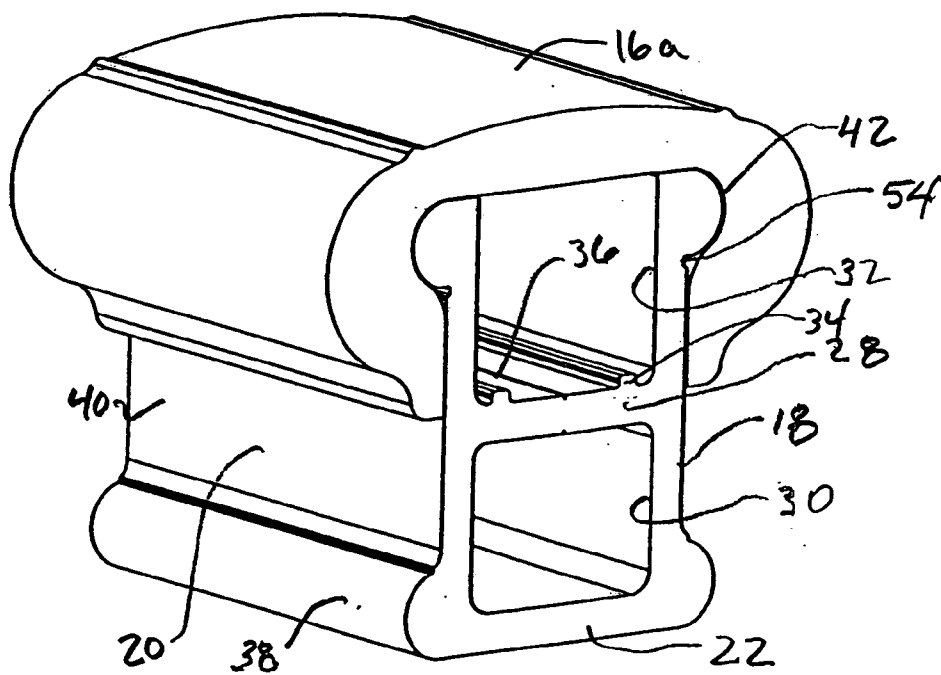

FIG. 8

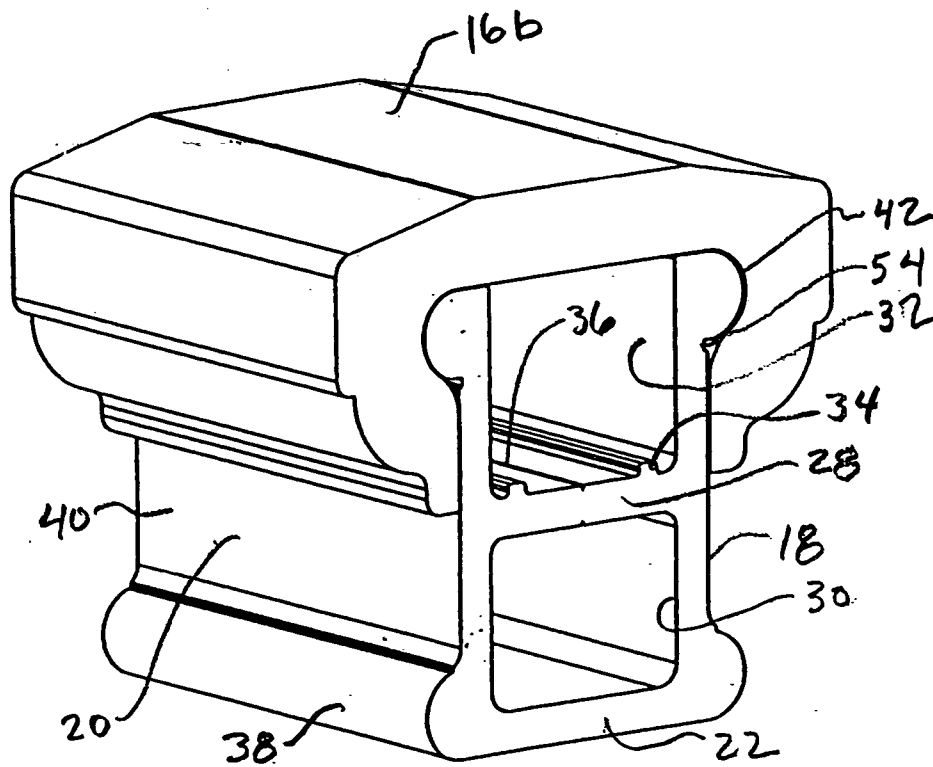
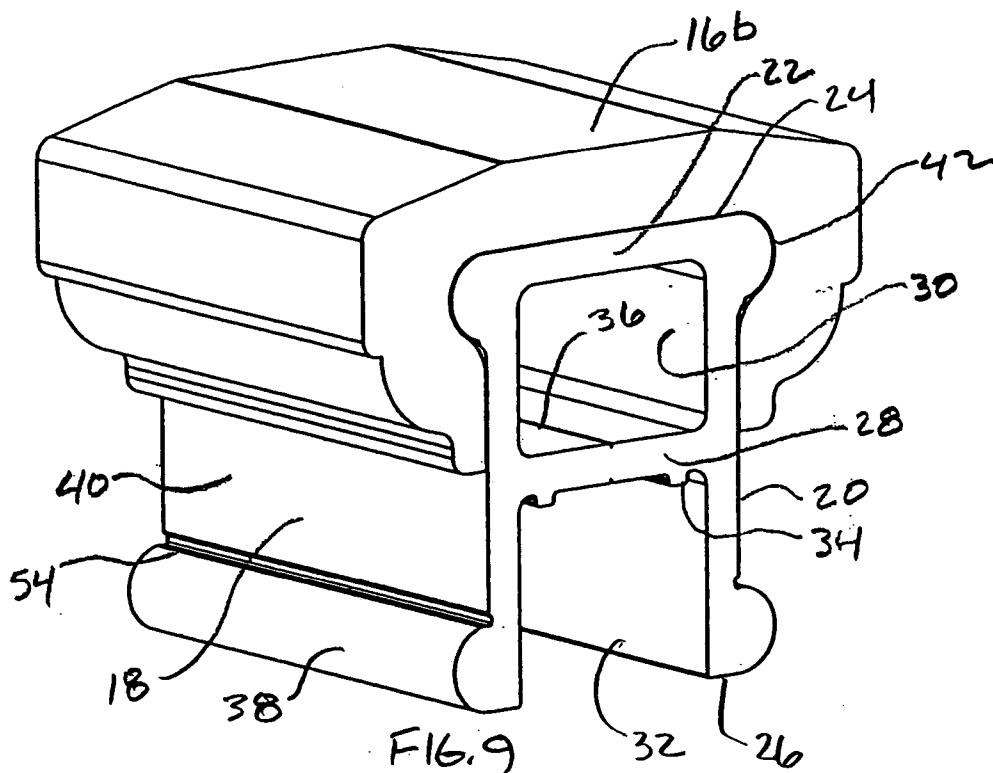

FIG. 10

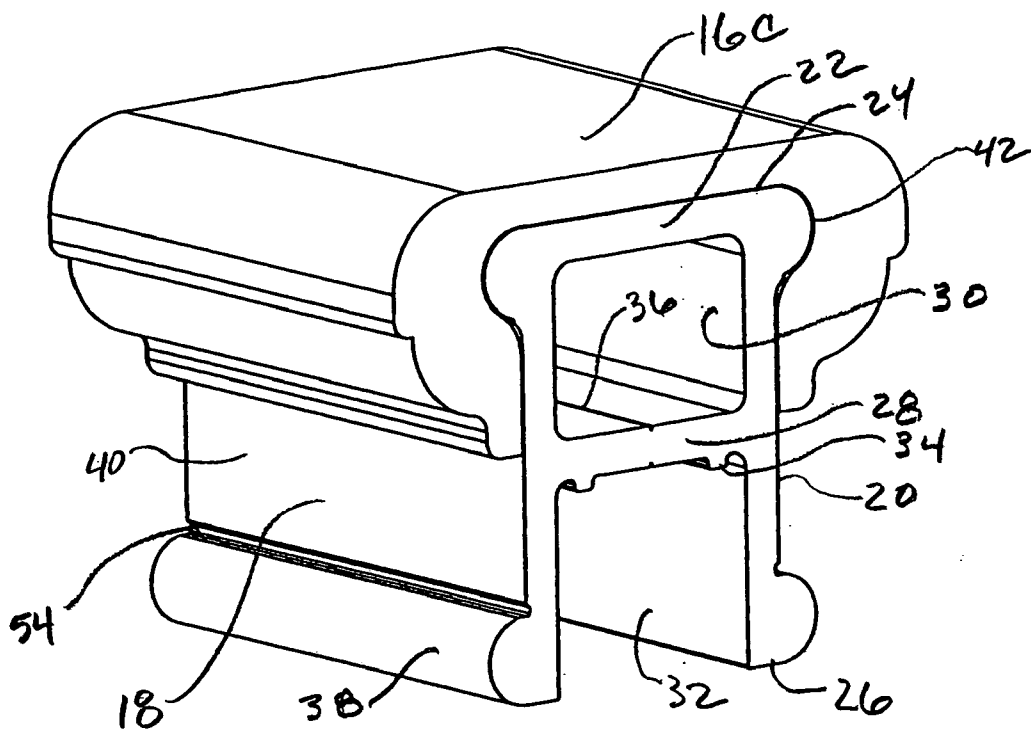

FIG. 11

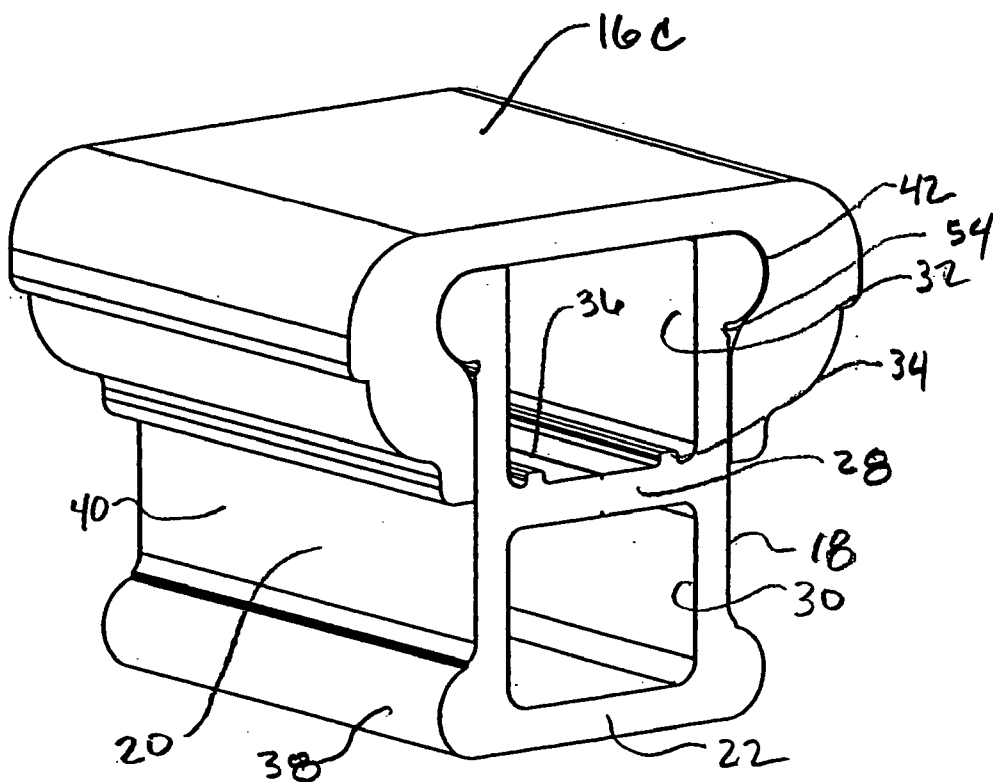

FIG. 12

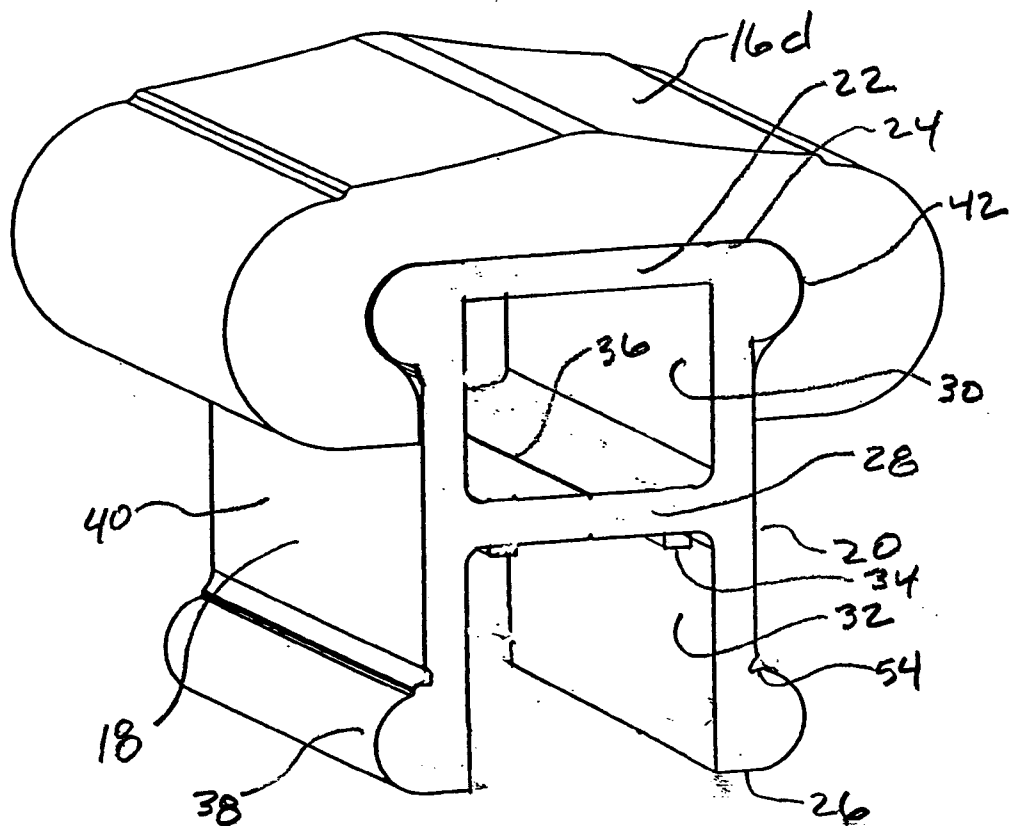

FIG. 13

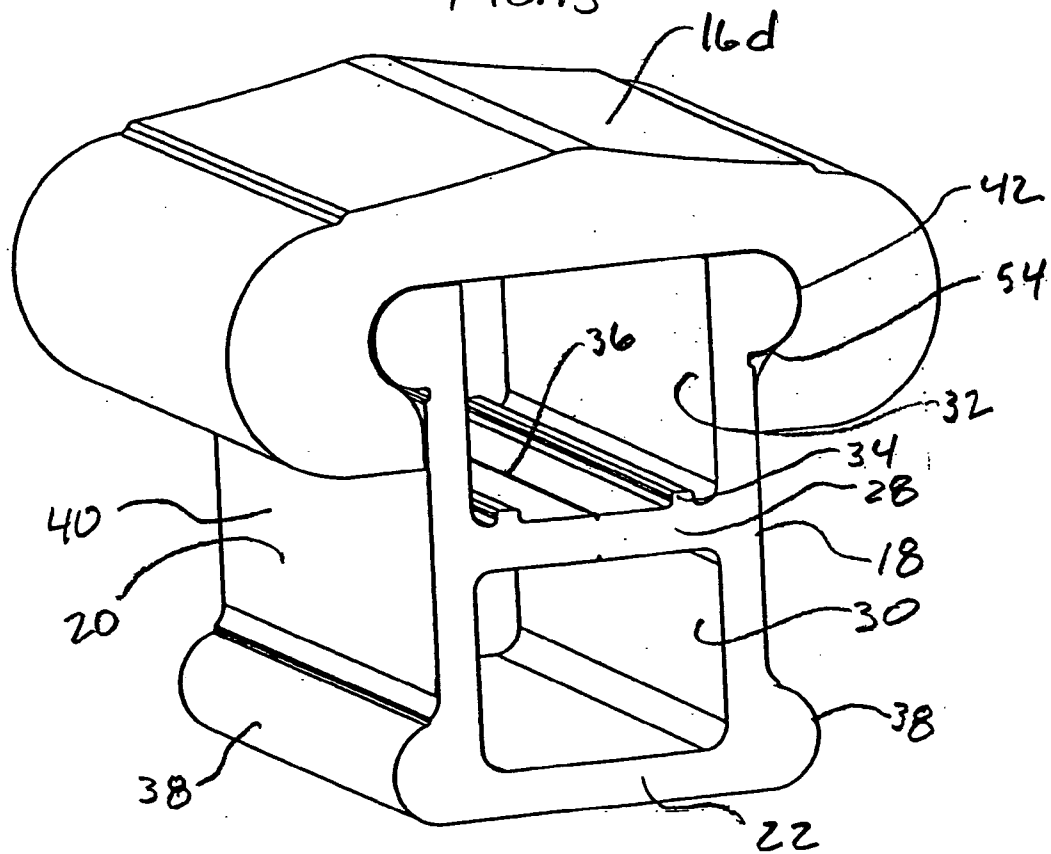

FIG. 14

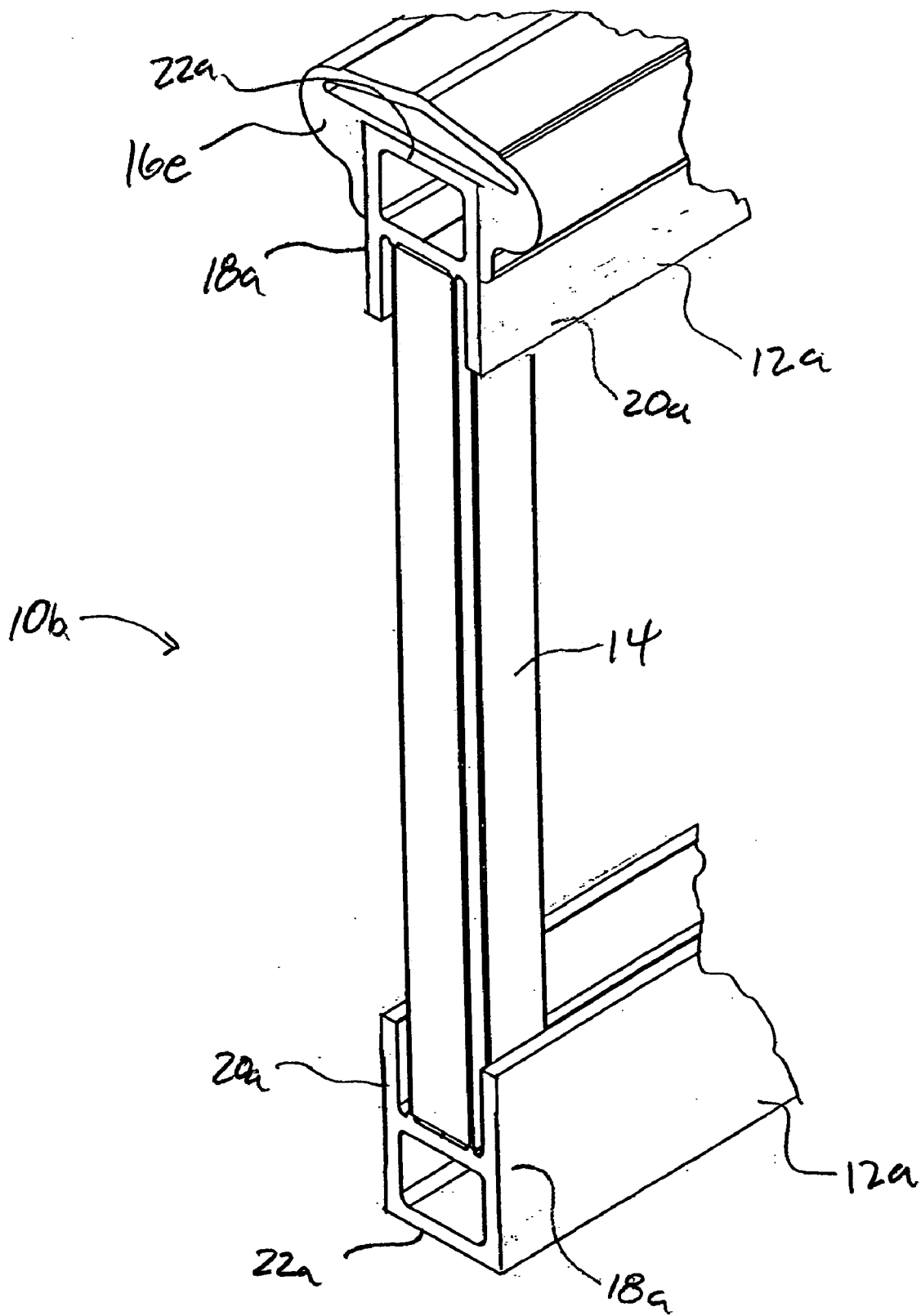

FIG. 15

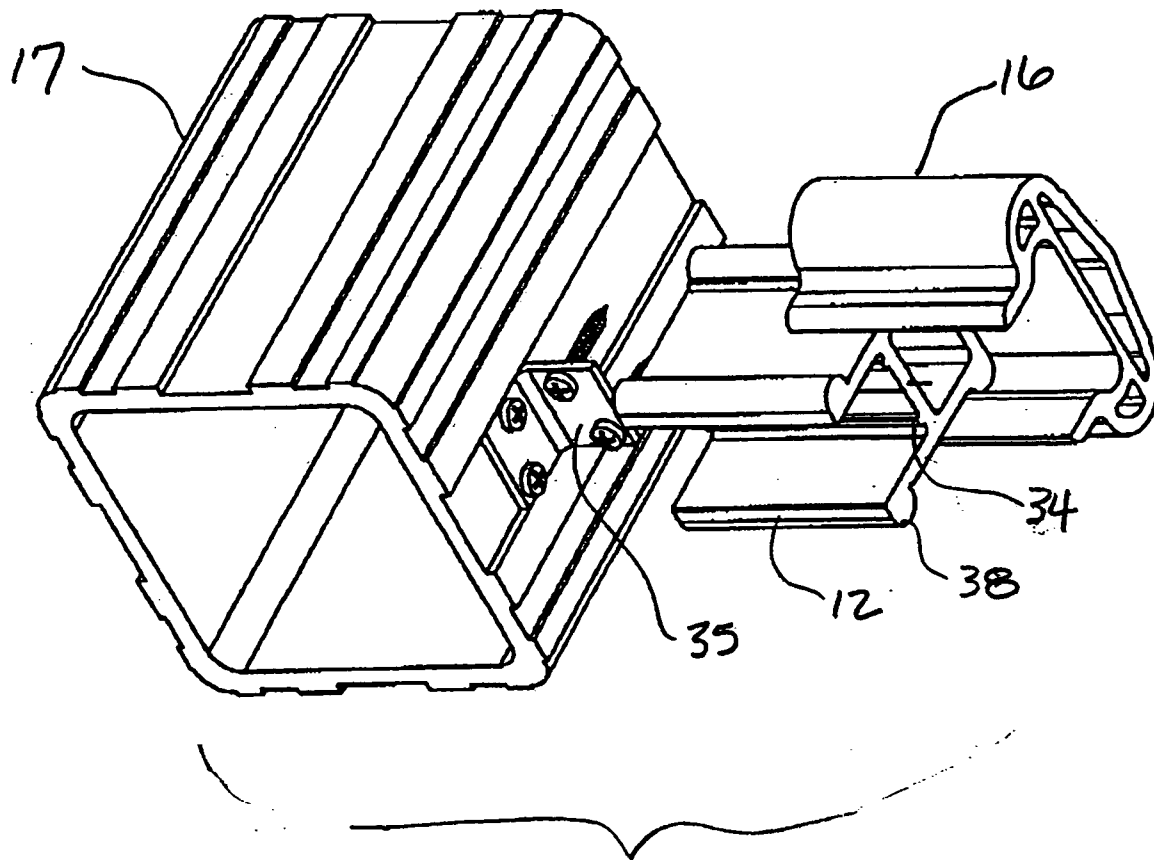

FIG. 16

METHOD OF FORMING A BARRIER

CROSS-REFERENCE TO RELATED APPLICATIONS

[0001] This application is a continuation-in-part of U.S. patent application Ser. No. 10/764,333, filed Jan. 23, 2004, entitled "MULTI-POSITION RAIL FOR A BARRIER," which claimed the benefit of U.S. Provisional Application Ser. No. 60/473,535, filed May 26, 2003, which applications are hereby incorporated by reference herein in their entireties, including but not limited to those portions that specifically appear hereinafter, the incorporation by reference being made with the following exception: In the event that any portion of the above-referenced applications is inconsistent with this application, this application supercedes said above-referenced applications.

STATEMENT REGARDING FEDERALLY SPONSORED RESEARCH OR DEVELOPMENT

[0002] Not Applicable.

BACKGROUND

[0003] 1. The Field of the Invention

[0004] The present disclosure relates generally to rails, and more particularly, but not exclusively, to rails that can be used in various positions and orientations as part of a barrier system.

[0005] 2. Description of Related Art

[0006] Rails are known in the art for use in decks, porches, stairs, and fences for example. Such rails are useful in providing a secure barrier and adding to the aesthetic appearance of structures. Rails are commonly used with upright members such as pickets, planks or balusters of various sizes, configurations and spacing. Moreover, rails are often used as support members on the bottom of the barrier and towards the top of the barrier. The configuration of bottom rails is often different than the configuration of top rails. Thus, rails of multiple designs are often required in a single barrier system.

[0007] Also, it is common to use a particular style of rail with different types of upright members in different settings. Therefore, manufacturing and installation of barrier systems often requires the use of tools and machinery to form the rails to the desired configuration to be compatible with the particular upright members to be used.

[0008] Rails made of durable materials often have a more attractive appearance, but may be more difficult to cut or otherwise shape into condition for use with a particular upright member. Moreover, cutting of the rails to accommodate the upright members may weaken the rails.

[0009] The use of a different design for top rails as compared to bottom rails may increase the difficulty in providing proper inventory of barrier components. Also, the need to accommodate upright members of various different shapes and spacings may increase the amount of inventory of components required, and may also increase the difficulty and cost of installing the barrier.

[0010] The prior art is thus characterized by several disadvantages that are addressed by the present disclosure. The

present disclosure minimizes, and in some aspects eliminates, the above-mentioned failures, and other problems, by utilizing the methods and structural features described herein.

[0011] The features and advantages of the disclosure will be set forth in the description which follows, and in part will be apparent from the description, or may be learned by the practice of the disclosure without undue experimentation. The features and advantages of the disclosure may be realized and obtained by means of the instruments and combinations particularly pointed out in the appended claims.

BRIEF DESCRIPTION OF THE DRAWINGS

[0012] The features and advantages of the disclosure will become apparent from a consideration of the subsequent detailed description presented in connection with the accompanying drawings in which:

[0013] **FIG. 1** is a perspective break-away view of a barrier system of the present disclosure;

[0014] **FIG. 2** is a perspective break-away view of a rail in a first orientation with a cover attached thereto;

[0015] **FIG. 3** is a perspective break-away view of a rail in a second orientation with a cover attached thereto;

[0016] **FIG. 4** is an end view of a rail with a cap attached thereto;

[0017] **FIG. 5** is a perspective break-away view of the rail of **FIG. 4**;

[0018] **FIG. 6** is a perspective break-away view of an alternative barrier system with the rail of the present disclosure on the bottom, and an alternative rail on the top;

[0019] **FIG. 7** is a perspective view of a rail in a first orientation with an alternative embodiment cover attached thereto;

[0020] **FIG. 8** is a perspective view of a rail in a second orientation with the alternative embodiment cover of **FIG. 7** attached thereto;

[0021] **FIG. 9** is a perspective view of a rail in a first orientation with a further alternative embodiment cover attached thereto;

[0022] **FIG. 10** is a perspective view of a rail in a second orientation with the alternative embodiment cover of **FIG. 9** attached thereto;

[0023] **FIG. 11** is a perspective view of a rail in a first orientation with an additional alternative embodiment cover attached thereto;

[0024] **FIG. 12** is a perspective view of a rail in a second orientation with the alternative embodiment cover of **FIG. 11** attached thereto;

[0025] **FIG. 13** is a perspective view of a rail in a first orientation with another alternative embodiment cover attached thereto;

[0026] **FIG. 14** is a perspective view of a rail in a second orientation with the alternative embodiment cover of **FIG. 13** attached thereto;

[0027] FIG. 15 is a perspective break-away view of another alternative embodiment barrier system; and

[0028] FIG. 16 is an exploded perspective view of a rail, rail cover, and post.

DETAILED DESCRIPTION

[0029] For the purposes of promoting an understanding of the principles in accordance with the disclosure, reference will now be made to the embodiments illustrated in the drawings and specific language will be used to describe the same. It will nevertheless be understood that no limitation of the scope of the disclosure is thereby intended. Any alterations and further modifications of the inventive features illustrated herein, and any additional applications of the principles of the disclosure as illustrated herein, which would normally occur to one skilled in the relevant art and having possession of this disclosure, are to be considered within the scope of the disclosure claimed.

[0030] It must be noted that, as used in this specification and the appended claims, the singular forms “a,” “an,” and “the” include plural referents unless the context clearly dictates otherwise.

[0031] In describing and claiming the present disclosure, the following terminology will be used in accordance with the definitions set out below.

[0032] As used herein, the terms “comprising,” “including,” “containing,” “characterized by,” and grammatical equivalents thereof are inclusive or open-ended terms that do not exclude additional, unrecited elements or method steps.

[0033] “Interference fit” as used herein shall refer to the concept of a connection between two members in which a portion of one member abuts some portion of the other member in a manner that contactably blocks the separation of the two members.

[0034] Referring now to FIG. 1, an exemplary perspective break-away view is shown of a barrier system of the present disclosure, indicated generally at 10. The barrier system 10 may form a railing system for use with decks, porches, stairs, or walkway, or a fence for use in defining a property boundary, for example.

[0035] The barrier system 10 may include one or more rails 12 configured to be supported in a laterally extending orientation. The rails 12 may be positioned at an upper portion and at a lower portion of the barrier system 10. Alternatively, it will also be appreciated that the barrier system 10 may utilize a single rail 12.

[0036] The barrier system 10 may also include a boundary-defining barrier means 14. The boundary-defining barrier means 14 may include upright members such as pickets, planks, balusters, or walls for example, of any of a variety of shapes, sizes and styles, for defining a boundary. In the embodiment of FIG. 1, the boundary-defining barrier means 14 extends between the rails 12 to form part of a barrier system 10. It will be understood that the boundary-defining barrier means 14 may include a plurality of upright members.

[0037] The barrier system 10 may also include a rail cover 16 for receiving a rail 12. The rail cover 16 may be positioned on the top of the barrier system 10 and may be

shaped in various different styles and configurations to provide an aesthetically pleasing appearance. Examples of some of the various different styles of covers are depicted in FIGS. 7-14, designated by reference numerals 16a-16d. The rail cover 16 may also be configured so as to provide a gripping surface such that the rail cover 16 can be grasped to provide support to a person. Also, the rail cover 16 may have an exterior appearance similar to a solid wood rail. The rail cover 16 may cover only a portion of the rail 12 such that part of the rail 12 may remain visible even when the rail cover 16 is attached. Ends of the barrier system 10 may be supported by a structure or post 17, as shown in FIG. 16, for example. It will be appreciated that the certain embodiments of the barrier system 10 may be formed with the rail cover 16, whereas other embodiments of the barrier system 10 may be formed without the rail cover 16.

[0038] Details of the rail 12 will now be explained with particular reference to FIGS. 2-5. The rail 12 may include a first side wall 18 forming a first side of the rail 12, and a second side wall 20 forming a second side of the rail 12. The rail 12 may also have a cross wall 22 extending between the first side wall 18 and the second side wall 20. As shown in FIG. 2, the cross wall 22 may extend between the first side wall 18 and the second side wall 20 at a top side 24 of the rail 12. However, it will be appreciated that the rail 12 may be oriented such that the cross wall 22 may be on a bottom side 28 of the rail 12.

[0039] The rail 12 may also have one or more brace members 28 extending between the first side wall 18 and the second side wall 20. The brace member 28 may be a continuous wall or it may be formed as a series of discrete members positioned along the length of the rail 12 to help provide strength to the rail 12. The brace member 28 may be centrally located between the top side 24 and the bottom side 26 of the rail 12. However, it will be appreciated that the brace member 28 may be spaced at any distance between the top side 24 and the bottom side 26, and that any number of brace members 28 may be used.

[0040] A chamber 30 may be defined by the first side wall 18, the second side wall 20, the cross wall 22, and the brace member 28. Similarly, a channel 32 may be defined by the first side wall 18, the second side wall 20, and the brace member 28. It will be appreciated that the boundary-defining barrier means 14 may be received in the chamber 30 or the channel 32 as discussed more fully below.

[0041] The brace member 28 may have one or more ridges 34 for providing support to the brace member 28, for contacting the boundary-defining barrier means 14, or for locating and supporting brackets 35, as shown in FIG. 16, for attaching the rail 12 to a post 17 or support structure, for example. The brackets 35 may be formed in any manner known to those skilled in the art and may be attached to the rail 12 with screws or any other variety of fasteners known in the art. The ridges 34 may extend along a length of the brace member 28. The brace member 28 may also include grooves 36 for locating a center of the brace member 28 for receiving the screws or drill bits for making openings for the screws. The grooves 36 may also extend along the length of the brace member 28. It will be understood that embodiments of the brace member 28 may be formed without the ridges 34 or grooves 36, or that the quantity, shape and location of the ridges 34 and grooves 36 may vary within the scope of the present disclosure.

[0042] In one embodiment, the rail 12 may be formed in a one-piece unitary manner such that the cross wall 22 may be formed integrally with the rail 12 so as to be inseparable from the first side wall 18 and the second side wall 20. Accordingly, no joints or seams may be formed between the cross wall 22 and the first side wall 18 and the second side wall 20, or between the brace member 28 and the first side wall 18 and the second side wall 20, in this embodiment. It will be appreciated that other embodiments of the rail 12 may be constructed in separable components within the scope of the present disclosure.

[0043] The rail 12 may also include means 38 for engaging with the rail cover 16 to attach the rail 12 to the rail cover 16. The engaging means 38 may be in the form of protrusions extending away from the rail 12. In one embodiment, the first side wall 18 and the second side wall 20 may have exterior planar portions 40 and the engaging means 38 may be formed as protrusions that extend beyond the plane defined by the planar portions 40. The engaging means 38 may be curved and may have a radius defining a rounded configuration. However, it will be appreciated that the engaging means 38 may have various different shapes and configurations within the scope of the present disclosure. The engaging means 38 may be received in the rail cover 16 to form an interference fit to prevent the rail 12 from being pulled out of the rail cover 16.

[0044] It will be appreciated that the first side wall 18 and the second side wall 20 may have various different configurations, such as curved or angular shapes, and need not have the planar portions 40. The rail 12 may be inserted into an end of the rail cover 16 such that the engaging means 38 may be received in receiving means 42 formed in the rail cover 16. The receiving means 42 may be shaped to abut with the engaging means 38 to hold the rail 12 in place with respect to the rail cover 16. However, the rail 12 may slide with respect to the rail cover 16 in a direction along a longitudinal axis 44 of the rail 12 to locate the rail 12 in a desired position.

[0045] Alternatively, it will be appreciated that the rail 12 and/or rail cover 16 may be formed with flexible elastic properties that allow the rail 12 and/or rail cover 16 to deflect. The rail 12 can therefore be inserted into the rail cover 16 along the length of the rail cover 16 rather than at the end of the rail cover 16. The rail 12 and rail cover 16 may thus be configured to be connected together with a snap fit.

[0046] The engaging means 38 may be formed on both the top side 24 and the bottom side 26 of the rail 12. Accordingly, as can be seen by inspection of FIGS. 2 and 3, the rail 12 may be attached to the rail cover 16 such that the cross wall 22 may be positioned within the rail cover 16, as shown in FIG. 2. Alternatively, the rail 12 may be rotated by substantially 180 degrees with respect to the rail cover 16, about the longitudinal axis 44, such that the channel 32 may be positioned within the rail cover 16, as shown in FIG. 3. In other words, the rail 12 may be placed in a first orientation, as shown in FIG. 2, or the rail 12 may be inverted to a second orientation as shown in FIG. 3.

[0047] Attachment of the barrier means 14 to the rail 12 will now be described. The barrier means 14 may be received within the channel 32 as shown in FIG. 1. The barrier means 14 may contact the brace member 28 at the ridges 34 to be supported in an upward position. The first

side wall 18 and the second side wall 20 may support the barrier means 14 in a lateral direction.

[0048] To further support the barrier means 14 in a lateral direction along the length of the rail 12, a cap 46 may be placed over the channel 32 as shown in FIGS. 4-5. The cap 46 may have openings 48 for receiving the barrier means 14. The openings 48 may be formed in the cap 46 by any manner known in the art such as using a router, or punching, stamping or cutting for example. As such, the openings 48 may be placed in the cap 46 during manufacturing of the cap 46, such that the openings 48 have predetermined spacings, sizes and shapes. Alternatively, the openings 48 may be formed in the cap 46 at the time of assembling the barrier system 10, such that the spacing, size and shape of the openings 48 can be custom made. Placing the openings 48 in the cap 46 may provide an advantage in that the openings 48 need not be formed in the rail 12. Forming openings in the rail 12 may weaken the rail 12 when the rail 12 is formed of certain composite materials for example.

[0049] The cap 46 may be made of any suitable material known in the art such as vinyl, metal, or composite materials, for example. The cap 46 may have attaching means 50 that may include a shaped portion of the cap 46 configured for receiving the engaging means 38. Thus, the cap 46 may be attached to the rail 12 with an interference fit. The shape of the attaching means 50 may correspond to the shape of the engaging means 38 on the rail 12 to provide an aesthetically pleasing and tight fitting connection that may not create a protruding ledge that may be prone to snagging or accumulating debris. It will be appreciated that other attaching means such as fasteners or adhesives may also be used to attach the cap 46 to the rail 12 within the scope of the present disclosure.

[0050] Similar to the rail cover 16, the cap 46 may be attached to the rail 12 by sliding the cap 46 over an end of the rail 12, or by deflecting the cap 46 to snap the cap 46 onto the rail 12. The cap 46 may also include ledges 52 to facilitate aligning the cap 46 on the rail 12, and holding the cap 46 in position with respect to the rail 12. Moreover, the rail 12 may include slots 54 for receiving an edge portion of the cap 46 so that the connection between the cap 46 and the rail 12 may be more secure and aesthetically pleasing.

[0051] With the cap 46 secured to the rail 12, the barrier means 14 may be placed through the openings 48 such that the cap 46 may assist in providing proper spacing and support for the barrier means 14. The position of the cap 46 may be moved with respect to the rail 12 so that the openings 48 can be positioned as desired and the orientation of the barrier means 14 may be adjusted. Thus, assembly of the barrier system may be facilitated.

[0052] In an alternative orientation of the rail 12, as shown in FIGS. 3, 6, 8, 10, 12, and 14, a portion of the barrier means 14 may be received within the chamber 30. Holes 56 may be formed in the cross wall 22 to accommodate the barrier means 14, as best shown in FIG. 6. Similar to the openings 48 in the cap 46, the holes 56 may be formed in any manner known in the art, either as the rail 12 is manufactured, or as the barrier system 10 is assembled. Thus, the cross wall 22 may be used to support the barrier means 14 when the rail 12 is oriented with the cross wall 22 in contact with the barrier means 14. It will be understood that in this orientation, the cap 46 may not be required.

[0053] Accordingly, the cross wall 22 and the cap 46 may collectively form a supporting means for (i) supporting a first boundary-defining barrier means 14 in position with respect to the rail 12 when the rail 12 is disposed in a first orientation, and (ii) supporting a second boundary-defining barrier means 14 in position with respect to the rail 12 when the rail 12 is disposed in a second orientation, wherein the second orientation is rotated about the longitudinal axis 44 by substantially 180 degrees from the first orientation.

[0054] It will be appreciated that the rail 12 may be configured to be versatile to be used in various positions and orientations in the barrier system 10 within the scope of the present disclosure. For example, as shown in FIG. 1, the rail 12 may be used as part of the top rail and the bottom rail within the barrier system 10. Moreover, embodiments of the rail 12 may be positioned in a central portion of the barrier system 10. Various different shapes and styles of rail covers 16 may be accommodated by the rail 12. An alternative embodiment barrier system 10a, is shown in FIG. 6, in which the rail 12 may be used for only a bottom rail, and a different variety of rail, such as a connection rail or U-rail 58, may be used for a top rail. Similarly, the rail 12 may be used for only the top rail. Also, the rail 12 may be oriented such that the barrier means 14 may be received in the channel 32, or in the chamber 30.

[0055] In one embodiment, the U-rail 58 may include recesses 60. The recesses 60 may be configured to receive fasteners for attaching the U-rail 58 to the barrier means 14. It will be understood that the barrier means 14 may be substantially hollow and may have a central bore extending along a length of the barrier means 14. The bore may be defined by interior brace structure and the bore may be used for receiving fasteners to attach the U-rail to the barrier means 14. Alternatively, the barrier means 14 may be solid such that fasteners may be located as desired. The recesses 60 may be located in the top of the U-rail 58 and/or the sides of the U-rail. Accordingly, when a fastener is placed in the recess 60, the cover 16 may slide over the U-rail 58 without the fastener contacting the cover 16 to interfere with the sliding movement between the cover 16 and the U-rail 58. It will also be understood that recesses 60 may be formed in the rail 12 in a similar manner.

[0056] The engaging means 38 may be configured, in one aspect of the disclosure, to provide an aesthetically pleasing appearance. The rail 12 may be formed to be symmetrical, such that the external appearance of the rail 12 may be similar regardless of whether the rail 12 is oriented with the channel 32 on the top, or the cross wall 22 on the top.

[0057] The components of the barrier system 10 may be formed of various different suitable materials within the scope of the present disclosure. For example, components of the barrier system 10 may be formed of a PVC material, and/or a metal material. Also, the barrier system may be formed of a composite material made from materials such as a blend of wood flour and PVC resin, for example, and the components may have an extruded PVC vinyl top coating. The components of the present disclosure may also be formed of a composite of polypropylene or polyethylene and wood. Some embodiments may include inserts made of metal, such as aluminum, for added strength. Also, the barrier system components may be made from a pultrusion process with fiber reinforced material made from a blend of

fiberglass and PVC resin, for example, with an extruded acrylic top coating, or any other suitable material known in the art may also be used to form the components of the barrier system 10.

[0058] As used herein, the term "pultrusion" refers to a process for manufacturing reinforced profiles wherein a set of fibers is pulled through a resin bath and then through a heated die giving the profile its shape. After the profile passes through the die the profile may be cooled by air or water and cut into desired lengths. The resin used may be of various materials such as polyesters, vinyl esters, and epoxies for example. Furthermore, various types of fibers may be added in the pultrusion process to produce profiles having different characteristics, such as different strengths, hardnesses, or elasticities. The fiber may be either a fiber mat or a series of continuous fibers, or any other suitable fiber reinforcement. The pultruded fiber reinforced material may have components having high hardness and strength characteristics and an attractive high quality appearance.

[0059] Reference will now be made to FIG. 15 to describe another alternative embodiment barrier system, indicated generally at 10b. As previously discussed, the presently disclosed embodiments illustrated herein are merely exemplary of the possible embodiments of the disclosure, including that illustrated in FIG. 15. It will be appreciated that the alternative embodiment illustrated in FIG. 15 contains many of the same structures represented in FIGS. 1-14 and only the new or different structures will be explained to most succinctly explain the features of the embodiment illustrated in FIG. 15.

[0060] The alternative embodiment barrier system 10b may include a rail 12a. The rail 12a may include a first side wall 18a, a second side wall 20a, and a cross wall 22a. The first side wall 18a and the second side wall 20a may be characterized by an absence of protrusions. Moreover, the rail 12a may not include openings in the cross wall 22a, and the rail 12a may be utilized without a cap. A cover 16e may be configured to receive the rail 12a, and the rail 12a may be oriented in two positions. For example, the rail 12a may be oriented such that the cross wall 22a is on the top to form a top rail, or the rail 12a may be oriented such that the cross wall 22a is on the bottom to form a bottom rail.

[0061] It will be appreciated that the structure and apparatus disclosed herein is merely one example of a means for engaging (or engaging means), and it should be appreciated that any structure, apparatus or system for engaging which performs functions the same as, or equivalent to, those disclosed herein are intended to fall within the scope of a means for engaging, including those structures, apparatus or systems for engaging which are presently known, or which may become available in the future. Anything which functions the same as, or equivalently to, a means for engaging falls within the scope of this element.

[0062] Similarly, it will be appreciated that the structures and apparatus disclosed herein are merely exemplary of a boundary-defining barrier means, receiving means, supporting means, and attaching means, and it should be appreciated that any structure, apparatus or system which performs functions the same as, or equivalent to, those disclosed herein are intended to fall within the scope of a boundary-defining barrier means, receiving means, supporting means, or attaching means, including those structures, apparatus or

systems which are presently known, or which may become available in the future. Anything which functions the same as, or equivalently to, a boundary-defining barrier means, receiving means, supporting means, and attaching means falls within the scope of these elements, respectively.

[0063] In accordance with the features and combinations described above, a useful method of forming barriers includes the steps of:

[0064] (a) providing a plurality of rails each having a longitudinal axis, a channel on one side and a cross wall on an opposing side;

[0065] (b) orienting one of the rails in a first orientation and placing a first boundary-defining barrier means in the channel;

[0066] (c) orienting another of the rails in a second orientation rotated substantially 180 degrees from the first orientation about the longitudinal axis;

[0067] (d) forming at least one hole in the cross wall; and

[0068] (e) placing a second boundary-defining barrier means in the hole.

[0069] Those having ordinary skill in the relevant art will appreciate the advantages provide by the features of the present disclosure. For example, it is a feature of the present disclosure to provide a rail and barrier system that is simple in design and manufacture. Another feature of the present disclosure is to provide such a rail that is versatile to be used in various orientations and positions within the carrier system, such that inventory of barrier system components may be reduced. It is a further feature of the present disclosure, in accordance with one aspect thereof, to provide such a rail that has an aesthetically pleasing appearance and which allows for assembly with or without cutting holes in the rail.

[0070] In the foregoing Detailed Description, various features of the present disclosure are grouped together in single embodiments for the purpose of streamlining the disclosure. This method of disclosure is not to be interpreted as reflecting an intention that the claimed disclosure requires more features than are expressly recited in each claim. Rather, as the following claims reflect, inventive aspects lie in less than all features of the foregoing disclosed embodiments. Thus, the following claims are hereby incorporated into this Detailed Description by this reference, with each claim standing on its own as a separate embodiment of the present disclosure.

[0071] It is to be understood that the above-described arrangements are only illustrative of the application of the principles of the present disclosure. Numerous modifications and alternative arrangements may be devised by those skilled in the art without departing from the spirit and scope of the present disclosure and the appended claims are intended to cover such modifications and arrangements. Thus, while the present disclosure has been shown in the drawings and described above with particularity and detail, it will be apparent to those of ordinary skill in the art that numerous modifications, including, but not limited to, variations in size, materials, shape, form, function and manner of operation, assembly and use may be made without departing from the principles and concepts set forth herein.

1-25. (canceled)

26. A method of forming barriers, said method comprising the steps of:

(a) providing a plurality of rails each having a longitudinal axis, a channel on one side and a cross wall on an opposing side;

(b) orienting one of said rails in a first orientation and placing a first boundary-defining barrier means in said channel;

(c) orienting another of said rails in a second orientation rotated substantially 180 degrees from said first orientation about said longitudinal axis;

(d) forming at least one hole in said cross wall; and

(e) placing a second boundary-defining barrier means in said at least one hole.

27. The method of claim 26, further comprising placing a cap over said channel when said rail is in said first orientation.

28. The method of claim 27, further comprising forming openings in said cap for receiving said first boundary-defining barrier means.

29. The method of claim 26, further comprising attaching a cover to said rail when said rail is in said first orientation.

30. The method of claim 26, further comprising attaching a cover to said rail when said rail is in said second orientation.

31-68. (canceled)

69. A method of forming a barrier, said method comprising the steps of:

(a) providing a rail having a channel on one side and a chamber on an opposing side, said chamber being defined in part by a cross wall;

(b) forming at least one hole in said cross wall;

(c) placing said channel in a rail cover; and

(d) placing a boundary-defining barrier means in said chamber through said at least one hole.

70. The method of claim 69, wherein step (b) comprises forming a plurality of holes in said cross wall.

71. The method of claim 70, further comprising shaping and spacing said plurality of holes to correspond with said boundary-defining barrier means.

72. The method of claim 69, wherein step (c) comprises sliding said rail cover over an end of said rail along a longitudinal axis of said rail.

73. The method of claim 69, wherein step (c) comprises attaching said cover to said rail with an interference fit.

74. A method of forming a barrier, said method comprising the steps of:

(a) providing a rail having a channel on one side and a cross wall on an opposing side;

(b) forming at least one opening in a cap;

(c) placing said cross wall in a rail cover;

(d) placing said cap over said channel; and

(e) placing a boundary-defining barrier means in said channel through said at least one opening.

75. The method of claim 74, wherein step (b) comprises forming a plurality of openings in said cap.

76. The method of claim 75, further comprising shaping and spacing said plurality of openings to correspond with said boundary-defining barrier means.

77. The method of claim 74, wherein step (c) comprises sliding said rail cover over an end of said rail along a longitudinal axis of said rail.

78. The method of claim 74, wherein step (c) comprises attaching said cover to said rail with an interference fit.

79. The method of claim 74, wherein step (d) comprises sliding said cap over an end of said rail along a longitudinal axis of said rail.

80. The method of claim 74, wherein step (d) comprises attaching said cap to said rail with an interference fit.

81. The method of claim 74, wherein step (d) comprises deflecting said cap to attach said cap to said rail with a snap fit.

82. The method of claim 74, wherein step (d) further comprises inserting an edge of said cap in a slot in said rail.

83. The method of claim 74, wherein step (d) further comprises moving said cap with respect to said rail to adjust a position of said at least one opening.

84-85. (canceled)

86. A method of forming barriers, said method comprising the steps of:

- (a) providing a plurality of rails each having a longitudinal axis, a channel on one side and a cross wall on an opposing side;
- (b) orienting one of said rails in a first orientation and placing a first boundary-defining barrier means in said channel;
- (c) orienting another of said rails in a second orientation inverted from said first orientation;
- (d) forming at least one hole in said cross wall; and

(e) placing a second boundary-defining barrier means in said at least one hole.

87-93. (canceled)

94. A method of forming a barrier, said method comprising the steps of:

- (a) providing a rail cover configured for receiving a connection rail for attaching said rail cover to a boundary-defining barrier means;
- (b) providing a rail configured for being received in said rail cover in a first orientation and an inverted orientation with respect to said rail cover; and
- (c) using at least a portion of said rail to form at least one of a top rail and a bottom rail of said barrier.

95. The method of claim 94, wherein step (a) further comprises providing said rail cover in a configuration for obscuring said connection rail from view.

96. The method of claim 94, wherein step (c) comprises using said at least a portion of said rail to form said top rail and using another portion of said rail to form said bottom rail.

97. The method of claim 94, wherein step (c) comprises using said at least a portion of said rail to form said top rail without using said connection rail.

98. The method of claim 94, wherein step (c) comprises using said at least a portion of said rail to form said bottom rail.

99. The method of claim 94, further comprising providing said rail having a channel on one side and a cross wall on an opposing side.

100. The method of claim 99, further comprising placing a cap over said channel.

101. The method of claim 99, further comprising forming holes in said cross wall for receiving said boundary-defining barrier means.

* * * * *