

(19) World Intellectual Property  
Organization  
International Bureau



(43) International Publication Date  
25 November 2004 (25.11.2004)

PCT

(10) International Publication Number  
WO 2004/102815 A2

- (51) International Patent Classification<sup>7</sup>: H04B
- (21) International Application Number: PCT/US2004/014452
- (22) International Filing Date: 7 May 2004 (07.05.2004)
- (25) Filing Language: English
- (26) Publication Language: English
- (30) Priority Data:  
60/470,160 12 May 2003 (12.05.2003) US  
10/622,663 17 July 2003 (17.07.2003) US
- (71) Applicant (for all designated States except US): QUALCOMM INCORPORATED [US/US]; 5775 Morehouse Drive, San Diego, CA 92121 (US).
- (72) Inventor; and
- (75) Inventor/Applicant (for US only): AGRAWAL, Avneesh [IN/US]; 13040 Signature Place, #29, San Diego, CA 92130 (US).
- (74) Agents: WADSWORTH, Philip, R. et al.; 5775 Morehouse Drive, San Diego, CA 92121 (US).
- (81) Designated States (unless otherwise indicated, for every kind of national protection available): AE, AG, AL, AM,

AT, AU, AZ, BA, BB, BG, BR, BW, BY, BZ, CA, CH, CN, CO, CR, CU, CZ, DE, DK, DM, DZ, EC, EE, EG, ES, FI, GB, GD, GE, GH, GM, HR, HU, ID, IL, IN, IS, JP, KE, KG, KP, KR, KZ, LC, LK, LR, LS, LT, LU, LV, MA, MD, MG, MK, MN, MW, MX, MZ, NA, NI, NO, NZ, OM, PG, PH, PL, PT, RO, RU, SC, SD, SE, SG, SK, SL, SY, TJ, TM, TN, TR, TT, TZ, UA, UG, US, UZ, VC, VN, YU, ZA, ZM, ZW.

(84) Designated States (unless otherwise indicated, for every kind of regional protection available): ARIPO (BW, GH, GM, KE, LS, MW, MZ, NA, SD, SL, SZ, TZ, UG, ZM, ZW), Eurasian (AM, AZ, BY, KG, KZ, MD, RU, TJ, TM), European (AT, BE, BG, CH, CY, CZ, DE, DK, EE, ES, FI, FR, GB, GR, HU, IE, IT, LU, MC, NL, PL, PT, RO, SE, SI, SK, TR), OAPI (BF, BJ, CF, CG, CI, CM, GA, GN, GQ, GW, ML, MR, NE, SN, TD, TG).

Declarations under Rule 4.17:

— as to applicant's entitlement to apply for and be granted a patent (Rule 4.17(ii)) for the following designations AE, AG, AL, AM, AT, AU, AZ, BA, BB, BG, BR, BW, BY, BZ, CA, CH, CN, CO, CR, CU, CZ, DE, DK, DM, DZ, EC, EE, EG, ES, FI, GB, GD, GE, GH, GM, HR, HU, ID, IL, IN, IS, JP, KE, KG, KP, KR, KZ, LC, LK, LR, LS, LT, LU, LV, MA, MD, MG, MK, MN, MW, MX, MZ, NA, NI, NO, NZ, OM,

[Continued on next page]

(54) Title: SOFT HANDOFF WITH INTERFERENCE CANCELLATION IN A WIRELESS FREQUENCY HOPPING COMMUNICATION SYSTEM

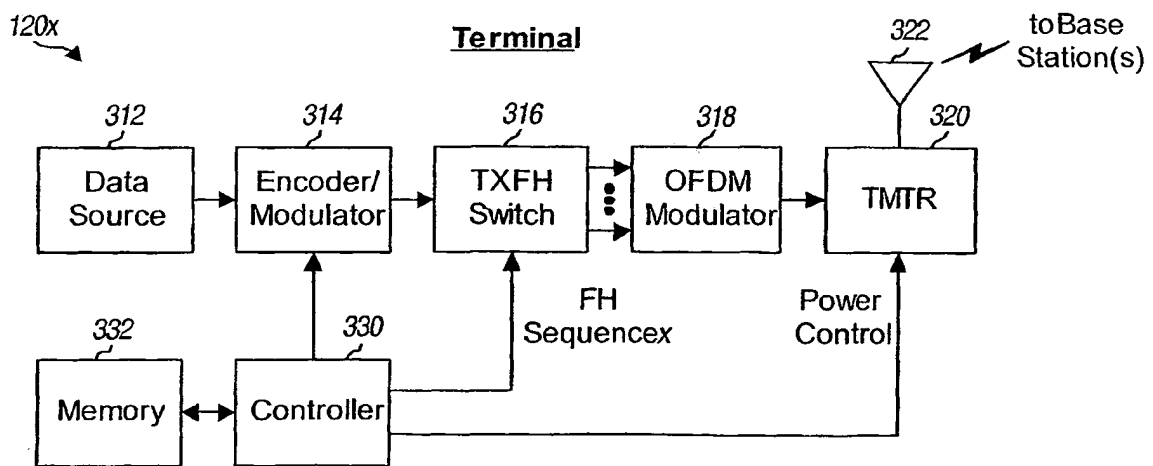

(57) Abstract: Techniques are provided to support soft handoff in a frequency hopping OFDMA system. Each sector concurrently supports "non-handoff" users and "soft-handoff" users. A non-handoff user communicates with only one sector, and a soft-handoff user communicates with multiple sectors simultaneously. Non-handoff users are assigned traffic channels by their sole sectors, and soft-handoff users are assigned traffic channels by their "serving" sectors. For each sector, the traffic channels assigned to the non-handoff users are orthogonal to one another and may or may not be orthogonal to the traffic channels assigned to the soft-handoff users. Each sector processes its received signal and recovers the data transmissions from the non-handoff users of that sector. Each sector then estimates the interference due to the non-handoff users and cancels the interference from the received signal. Each sector further processes its interference-canceled signal to recover the data transmissions from the soft-handoff users.

WO 2004/102815 A2



PG, PH, PL, PT, RO, RU, SC, SD, SE, SG, SK, SL, SY, TJ, TM, TN, TR, TT, TZ, UA, UG, UZ, VC, VN, YU, ZA, ZM, ZW. ARIPO patent (BW, GH, GM, KE, LS, MW, MZ, NA, SD, SL, SZ, TZ, UG, ZM, ZW), Eurasian patent (AM, AZ, BY, KG, KZ, MD, RU, TJ, TM), European patent (AT, BE, BG, CH, CY, CZ, DE, DK, EE, ES, FI, FR, GB, GR, HU, IE, IT, LU, MC, NL, PL, PT, RO, SE, SI, SK, TR), OAPI patent (BF, BJ, CF, CG, CI, CM, GA, GN, GQ, GW, ML, MR, NE, SN, TD, TG)

— as to the applicant's entitlement to claim the priority of the earlier application (Rule 4.17(iii)) for all designations

— as to the applicant's entitlement to claim the priority of the earlier application (Rule 4.17(iii)) for all designations

**Published:**

— without international search report and to be republished upon receipt of that report

For two-letter codes and other abbreviations, refer to the "Guidance Notes on Codes and Abbreviations" appearing at the beginning of each regular issue of the PCT Gazette.

# SOFT HANDOFF WITH INTERFERENCE CANCELLATION IN A WIRELESS FREQUENCY HOPPING COMMUNICATION SYSTEM

## CROSS-REFERENCE TO RELATED APPLICATIONS

This application is related to the following, all of which are assigned to the same assignee of this application.

Co-pending U.S. Application Serial No. 06/470,160 filed May 12, 2003 and entitled "Soft Handoff with Interference Cancellation in a Wireless Frequency Hopping Communication System."

## BACKGROUND

### I. Field

[0001] The present invention relates generally to communication, and more specifically to techniques for supporting soft handoff in a wireless frequency hopping communication system using interference cancellation.

### II. Background

[0002] In a frequency hopping communication system, data is transmitted on different frequency subbands in different time intervals, which may be referred to as "hop periods". These frequency subbands may be provided by orthogonal frequency division multiplexing (OFDM), other multi-carrier modulation techniques, or some other constructs. With frequency hopping, the data transmission hops from subband to subband in a pseudo-random manner. This hopping provides frequency diversity and allows the data transmission to better withstand deleterious path effects such as narrow-band interference, jamming, fading, and so on.

[0003] An orthogonal frequency division multiple access (OFDMA) system utilizes OFDM and can support multiple users simultaneously. For a frequency hopping OFDMA system, a data transmission for a given user may be sent on a "traffic" channel that is associated with a specific frequency hopping (FH) sequence. This FH sequence indicates the specific subband to use for the data transmission in each hop period.

Multiple data transmissions for multiple users may be sent simultaneously on multiple traffic channels that are associated with different FH sequences. These FH sequences may be defined to be orthogonal to one another so that only one traffic channel, and thus only one data transmission, uses each subband in each hop period. By using orthogonal FH sequences, the multiple data transmissions do not interfere with one another while enjoying the benefits of frequency diversity.

[0004] An OFDMA system may be deployed with multiple cells, where a cell typically refers to the coverage area of a base station. A data transmission on a given subband in one cell acts as interference to another data transmission on the same subband in a neighboring cell. To randomize inter-cell interference, the FH sequences for each cell are typically defined to be pseudo-random with respect to the FH sequences for neighboring cells. By using pseudo-random FH sequences for different cells, interference diversity is achieved and a data transmission for a user in one cell observes the average interference from the data transmissions for other users in other cells.

[0005] In a multi-cell OFDMA system, it is desirable to support "soft handoff", which is also referred to as "soft handover". Soft handoff is a process whereby a user communicates with multiple base stations simultaneously. Soft handoff can provide spatial diversity against deleterious path effects via transmission of data to or from multiple base stations at different locations. However, soft handoff is complicated when the system employs frequency hopping. This is because the FH sequences for one cell are pseudo-random (i.e., not orthogonal) with respect to the FH sequences for neighboring cells in order to randomize inter-cell interference. A user in soft handoff with multiple base stations may be instructed to use an FH sequence by a designated base station among the multiple base stations. The data transmission sent by the soft-handoff user will be orthogonal to the data transmissions sent by other users of the designated base station, but will be pseudo-random with respect to the data transmissions sent by users of other base stations. The soft-handoff user would cause interference to the users of the other base stations and would also receive interference from these users. The interference degrades the performance of all affected users, unless it is mitigated in some manner.

[0006] There is therefore a need in the art for techniques to support soft handoff in a frequency hopping OFDMA system.

## SUMMARY

[0007] Techniques are provided herein to support soft handoff in a wireless communication system (e.g., a frequency hopping OFDMA system). Each cell in the system may be partitioned into one or multiple sectors. Each sector in the system may concurrently support a set of "non-handoff" users and a set of "soft-handoff" users. A non-handoff user is one who is communicating with only one sector (i.e., not in soft handoff). A soft-handoff user is one who is communicating with multiple sectors simultaneously.

[0008] For each sector, each non-handoff user of that sector is assigned a traffic channel by that sector and each soft-handoff user of that sector is assigned a traffic channel by a "serving" or "anchor" sector for the soft-handoff user. The serving sector for a soft-handoff user is a designated sector among the multiple sectors with which the soft-handoff user is in communication. For each sector, the traffic channels assigned to the non-handoff users of that sector are orthogonal to one another and may or may not be orthogonal to the traffic channels assigned to the soft-handoff users of that sector, depending on whether or not that sector is the serving sector for the soft-handoff users.

[0009] For each sector, the non-handoff users of that sector may be power-controlled such that their data transmissions can be received and decoded by that sector in the presence of interference from the soft-handoff users of that sector as well as the interference from users in other sectors. The soft-handoff users may also be power-controlled such that their data transmissions can be decoded by their sectors while minimizing interference to the non-handoff users.

[00010] Each sector processes its received signal and recovers the data transmissions from the non-handoff users of that sector. Once the data transmissions from the non-handoff users have been decoded, each sector estimates the interference due to the non-handoff users of that sector and cancels the interference from the received signal. Each sector further processes its interference-canceled signal to recover the data transmissions from the soft-handoff users of that sector.

[00011] Various aspects and embodiments of the invention are described in further detail below.

## BRIEF DESCRIPTION OF THE DRAWINGS

[00012] The features, nature, and advantages of the present invention will become more apparent from the detailed description set forth below when taken in conjunction with the drawings in which like reference characters identify correspondingly throughout and wherein:

[00013] FIG. 1 shows an OFDMA system;

[00014] FIG. 2 illustrates frequency hopping for one sector in the OFDMA system;

[00015] FIG. 3 shows a block diagram of a terminal;

[00016] FIG. 4A shows a block diagram of a base station in a synchronous system;

[00017] FIG. 4B shows a block diagram of a base station in an asynchronous system;

[00018] FIG. 5 shows a block diagram of a receive (RX) data processor within the base station in the synchronous system;

[00019] FIG. 6 shows a block diagram of an interference estimator and an interference canceller within the RX data processor;

[00020] FIG. 7 shows a block diagram of an OFDM demodulator/RX data processor within the base station in the asynchronous system;

[00021] FIG. 8 shows a block diagram of an interference estimator and an interference canceller within the OFDM demodulator/RX data processor;

[00022] FIG. 9 shows a flow diagram for transmitting data by the terminal; and

[00023] FIG. 10 shows a flow diagram for receiving data transmissions from multiple terminals by the base station.

## DETAILED DESCRIPTION

[00024] The word “exemplary” is used herein to mean “serving as an example, instance, or illustration.” Any embodiment or design described herein as “exemplary” is not necessarily to be construed as preferred or advantageous over other embodiments or designs.

[00025] FIG. 1 shows an exemplary OFDMA system 100 that supports a number of users. System 100 includes a number of base stations 110 that provide communication for a number of terminals 120. A base station is a fixed station used for communicating with the terminals and may also be referred to as an access point, a Node B, or some other terminology. Terminals 120 are typically dispersed throughout the system, and each terminal may be fixed or mobile. A terminal may also be referred to as a mobile

station, a user equipment (UE), a wireless communication device, or some other terminology.

[00026] Each terminal may communicate with one or multiple base stations on the forward link and/or one or multiple base stations on the reverse link at any given moment. This depends on whether or not the terminal is active, whether or not soft handoff is supported, and whether or not the terminal is in soft handoff. The forward link (i.e., downlink) refers to the communication link from the base station to the terminal, and the reverse link (i.e., uplink) refers to the communication link from the terminal to the base station. In FIG. 1, terminal 120c is in soft handoff on the reverse link with base stations 110a, 110b, and 110c, terminal 120d is in soft handoff with base stations 110a and 110c, and terminal 120g is in soft handoff with base stations 110b and 110c. The remaining terminals are not in soft handoff. For simplicity, forward link transmissions are not shown in FIG. 1.

[00027] A system controller 130 couples to base stations 110 and may perform a number of functions such as (1) coordination and control for base stations 110, (2) routing of data among these base stations, and (3) access and control of the terminals served by these base stations.

[00028] Each base station 110 provides coverage for a respective geographic area 102. The term "cell" can refer to a base station and/or its coverage area, depending on the context in which the term is used. To increase capacity, the coverage area of each base station may be partitioned into multiple sectors (e.g., three sectors 104a, 104b, and 104c). Each sector may be served by a corresponding base transceiver subsystem (BTS). The term "sector" can refer to a BTS and/or its coverage area, depending on the context in which the term is used. For a sectorized cell, the base station for that cell typically includes the BTSs for all of the sectors of that cell. The following description assumes that each cell is partitioned into multiple sectors. For simplicity, in the following description, the term "base station" is used generically for both a fixed station that serves a cell and a fixed station that serves a sector. The base stations for all sectors of the same cell are typically implemented within one physical base station for that cell.

[00029] The techniques described herein may be used to support soft handoff, whereby a terminal concurrently communicates with multiple cells. The base stations for these cells are included in the terminal's active set. These techniques may also be used to support "softer handoff", which is a process whereby a terminal concurrently

communicates with multiple sectors of the same cell. The base stations for these sectors (which are typically parts of the same physical base station) are included in the terminal's active set. For simplicity, in the following description, the term "soft handoff" generically refers to the case in which a terminal concurrently communicates with multiple cells as well as the case in which a terminal concurrently communicates with multiple sectors of the same cell.

**[00030]** The techniques described herein may be used for a synchronous system in which the timings of the base stations in the system are synchronized to a common clock source (e.g., GPS). These techniques may also be used for an asynchronous system in which the timings of the base stations in the system are not synchronized. For clarity, various details are described below for a synchronous system. Moreover, the primary users for each sector (defined below) are assumed to be synchronized with the base station for the sector.

**[00031]** OFDMA system 100 utilizes OFDM, which is a modulation technique that effectively partitions the overall system bandwidth into a number of ( $N$ ) orthogonal frequency subbands, where  $N > 1$  and is typically a power of two. These subbands are also commonly referred to as tones, sub-carriers, bins, and frequency subchannels. With OFDM, each subband is associated with a respective sub-carrier that may be modulated with data. In some OFDM systems, only  $N_D$  subbands are used for data transmission,  $N_P$  subbands are used for pilot transmission, and  $N_G$  subbands are not used and serve as guard subbands to allow the systems to meet spectral mask requirements, where  $N = N_D + N_P + N_G$ . For simplicity, the following description assumes that all  $N$  subbands can be used for data transmission.

**[00032]** FIG. 2 illustrates frequency hopping for one sector in the OFDMA system. Frequency hopping may be used to obtain various benefits including frequency diversity against deleterious path effects and interference randomization, as described above. For this example,  $N = 8$ , and the eight subbands are assigned indices of 1 through 8. Up to eight traffic channels may be defined whereby each traffic channel uses one of the eight subbands in each hop period. A hop period may be defined to be equal to the duration of one or multiple OFDM symbols.

**[00033]** Each traffic channel is associated with a different FH sequence. The FH sequences for all traffic channels in the sector may be generated based on an FH

function  $f_s(k, T)$ , where  $k$  denotes the traffic channel number or identifier (ID) and  $T$  denotes system time, which is given in units of hop periods.  $N$  different FH sequences may be generated with  $N$  different values of  $k$  in the FH function  $f_s(k, T)$ . The FH sequence for each traffic channel indicates the specific subband to use for that traffic channel in each hop period.

[00034] FIG. 2 shows the subbands used for two traffic channels 1 and 4. The FH sequence and subbands for traffic channel 1 are represented by the shaded boxes. The FH sequence and subbands for traffic channel 4 are represented by the diagonal-hashed boxes. It can be seen in FIG. 2 that each traffic channel dynamically hops from subband to subband in a pseudo-random manner determined by its FH sequence. In this example, the FH sequence for traffic channel 4,  $f_s(4, T)$ , is a vertically shifted version of the FH sequence for channel 1,  $f_s(1, T)$ . The subbands used for traffic channel 4 are related to the subbands used for traffic channel 1 as follows:  

$$f_s(4, T) = (f_s(1, T) + 3) \bmod N.$$

[00035] To avoid intra-sector interference, each sector may use orthogonal FH sequences for its traffic channels. The FH sequences are orthogonal to one another if no two FH sequences use the same subband in any hop period  $T$ . This orthogonality condition may be attained by defining the FH sequences for each sector to be vertically shifted versions of one another, as shown in FIG. 2. The traffic channels for each sector would then be orthogonal to one another because they are associated with orthogonal FH sequences. By allowing only one traffic channel to use each subband in each hop period, interference is avoided among multiple data transmissions sent on multiple traffic channels in the same sector.

[00036] For a multi-sector OFDMA system, data transmissions for users in one sector interfere with data transmissions for users in other sectors. To randomize inter-sector interference, pseudo-random FH functions may be used for different sectors. For example, the FH function  $f_{s_1}(k, T)$  for sector  $s_1$  may be defined to be pseudo-random with respect to the FH function  $f_{s_2}(m, T)$  for sector  $s_2$ . In this case, the FH sequence used by sector  $s_1$  for traffic channel  $k$  will be pseudo-random with respect to the FH sequence used by sector  $s_2$  for traffic channel  $m$ , where  $k$  may or may not be equal to  $m$ . Interference between traffic channels  $k$  and  $m$  occurs whenever a "collision" occurs

between the FH sequences for these traffic channels, i.e., whenever  $f_{s_1}(k, T) = f_{s_2}(m, T)$  and traffic channels  $k$  and  $m$  both use the same subband in the same hop period. However, the interference will be randomized due to the pseudo-random nature of the FH functions  $f_{s_1}(k, T)$  and  $f_{s_2}(m, T)$ .

[00037] The FH sequences for each sector may thus be defined to be:

1. Orthogonal to each other to avoid intra-sector interference, and
2. Pseudo-random with respect to the FH sequences for neighboring sectors to randomize inter-sector interference.

With the above constraints, a user assigned with traffic channel  $k$  by one sector will be orthogonal to all other users assigned with other traffic channels by the same sector. However, this user will not be orthogonal to all users in a neighboring sector, which uses a different FH function.

[00038] Referring back to FIG. 1, each sector concurrently supports a set of non-handoff users and a set of soft-handoff users. Each user may communicate with one or multiple sectors, depending on whether or not the user is in soft handoff. The sector or sectors with which a user currently communicates are included in an "active set". For a non-handoff user, the active set includes a single sector, which is the serving sector for that user. For a soft-handoff user, the active set includes multiple sectors, and one of these sectors (e.g., the strongest received sector) is designated as the serving sector for the soft-handoff user.

[00039] The non-handoff users of each sector are assigned traffic channels with orthogonal FH sequences by that sector and thus do not interfere with each other. Each soft-handoff user is assigned a traffic channel by its serving sector. Each soft-handoff user is orthogonal to, and does not interfere with, other users in its serving sector. However, each soft-handoff user will not be orthogonal to other users in other sectors in its active set. Thus, the soft-handoff users of each sector may or may not interfere with the non-handoff users of that sector. This depends on whether the soft-handoff users have been assigned traffic channels by that sector or by some other sectors.

[00040] For each sector, the non-handoff users of that sector may be power-controlled such that their data transmissions can be decoded by that sector in the presence of interference from the soft-handoff users of that sector as well as interference from the users in other sectors. The soft-handoff users may also be power-controlled

such that their data transmissions can be decoded by the sectors in their active sets while minimizing interference to the non-handoff users.

[00041] In one embodiment, each sector processes its received signal and recovers the data transmissions from the non-handoff users of that sector. Each sector then estimates the interference due to the non-handoff users and cancels the interference from the received signal. Each sector further processes its interference-canceled signal to recover the data transmissions from the soft-handoff users of that sector.

[00042] Each sector may also be viewed as concurrently supporting a set of "primary" users and a set of "secondary" users. For each sector, a primary user is one who has been assigned a traffic channel by that sector, and a secondary user is one who has been assigned a traffic channel by another sector. The primary users of each sector include (1) non-handoff users of that sector and (2) soft-handoff users whose serving sector is that sector. The secondary users of each sector include soft-handoff users whose serving sectors are some other sectors besides that sector.

[00043] In another embodiment, each sector processes its received signal and recovers the data transmissions from the primary users of that sector (which include non-handoff users of that sector as well as soft-handoff users assigned traffic channels by that sector). Each sector then estimates the interference due to the primary users and cancels the interference from the received signal. Each sector further processes its interference-canceled signal to recover the data transmissions from the secondary users of that sector (which are assigned traffic channels by other sectors).

[00044] Each sector may recover the data transmissions from the users in other manners than the two embodiments described above, and this is within the scope of the invention. In general, it is desirable to cancel as much interference as possible. However, the ability to cancel the interference due to a given user is dependent on the ability to correctly decode the data transmission from that user, which may in turn be dependent on other factors such as, for example, the manner in which the user is power controlled.

[00045] FIG. 3 shows a block diagram of an embodiment of a terminal 120x, which is one of the terminals in OFDMA system 100. Terminal 120x may be for a non-handoff user or a soft-handoff user. For simplicity, only the transmitter portion of terminal 120x is shown in FIG. 3.

[00046] Within terminal 120x, an encoder/modulator 314 receives traffic data from a data source 312 and control data and other data from a controller 330. The traffic data is designated for transmission on traffic channel  $x$ , which is assigned to terminal 120x by the serving sector for the terminal. Encoder/modulator 314 formats, encodes, interleaves, and modulates the received data and provides modulation symbols (or simply, "data symbols"). Each modulation symbol is a complex value for a specific point in a signal constellation corresponding to the modulation scheme used for that modulation symbol.

[00047] A transmit frequency hopping (TX FH) switch 316 receives the data symbols and provides these symbols onto the proper subbands for traffic channel  $x$ . Traffic channel  $x$  is associated with FH sequence  $x$ , which indicates the specific subband to use for traffic channel  $x$  in each hop period  $T$ . FH sequence  $x$  may be generated by controller 330 based on the FH function  $f_s(k, T)$  for the serving sector. TX FH switch 316 may also provide pilot symbols on pilot subbands and further provides a signal value of zero for each subband not used for pilot or data transmission. For each OFDM symbol period, TX FH switch 316 provides  $N$  "transmit" symbols (which are comprised of data symbols, pilot symbols, and zero-signal values) for the  $N$  subbands.

[00048] An OFDM modulator 318 receives the  $N$  transmit symbols for each OFDM symbol period and provides a corresponding OFDM symbol. OFDM modulator 318 typically includes an inverse fast Fourier transform (IFFT) unit and a cyclic prefix generator. For each OFDM symbol period, the IFFT unit transforms the  $N$  transmit symbols to the time domain using an  $N$ -point inverse FFT to obtain a "transformed" symbol that contains  $N$  time-domain "chips". Each chip is a complex value to be transmitted in one chip period. The cyclic prefix generator then repeats a portion of each transformed symbol to form an OFDM symbol that contains  $N + C_p$  chips, where  $C_p$  is the number of chips being repeated. The repeated portion is often referred to as a cyclic prefix and is used to combat inter-symbol interference (ISI) caused by frequency selective fading. An OFDM symbol period corresponds to the duration of one OFDM symbol, which is  $N + C_p$  chip periods. OFDM modulator 318 provides a stream of OFDM symbols.

[00049] A transmitter unit (TMTR) 320 receives and processes the OFDM symbol stream to obtain a modulated signal. Transmitter unit 320 may further adjust the

amplitude of the OFDM symbols and/or the modulated signal based on a power control signal received from controller 330. The modulated signal is transmitted from an antenna 322 to the base station(s) in the active set for terminal 120x.

[00050] FIG. 4A shows a block diagram of an embodiment of a base station 110x in a synchronous OFDMA system. Base station 110x is the fixed station for sector  $s_x$ . For simplicity, only the receiver portion of base station 110x is shown in FIG. 4.

[00051] The modulated signals transmitted by the terminals within the coverage of base station 110x are received by an antenna 412. The received signal from antenna 412 may include (1) one or more modulated signals from non-handoff users of sector  $s_x$  and (2) one or more modulated signals from soft-handoff users of sector  $s_x$ . The received signal is provided to and processed by a receiver unit (RCVR) 414 to obtain samples. An OFDM demodulator 416 then processes the samples and provides "received" symbols, which are noisy estimates of the combined transmit symbols sent by all terminals received by base station 110x. OFDM demodulator 416 typically includes a cyclic prefix removal unit and an FFT unit. For each OFDM symbol period, the cyclic prefix removal unit removes the cyclic prefix in each received OFDM symbol to obtain a received transformed symbol. The FFT unit then transforms each received transformed symbol to the frequency domain with an N-point FFT to obtain N received symbols for the N subbands.

[00052] An RX data processor 420 obtains the N received symbols for each OFDM symbol period and processes these symbols to obtain decoded data for each terminal transmitting to base station 110x. The processing by RX data processor 420 is described in detail below. The decoded data for each terminal may be provided to a data sink 422 for storage.

[00053] Controllers 330 and 430 direct the operation at terminal 120x and base station 110x, respectively. Memory units 332 and 432 provide storage for program codes and data used by controllers 330 and 430, respectively.

[00054] FIG. 4B shows a block diagram of an embodiment of a base station 110y in an asynchronous OFDMA system. For an asynchronous system, the timing of the secondary users may be different from that of the primary users. An OFDM demodulator/RX data processor 440 performs OFDM demodulation for each user based on that user's timing. OFDM demodulator/RX data processor 440 also performs interference cancellation on time-domain symbols, as described below.

[00055] The following description is for the embodiment whereby a primary user of sector  $s_x$  is one assigned a traffic channel by sector  $s_x$ , and a secondary user of sector  $s_x$  is one assigned a traffic channel by another sector besides sector  $s_x$ . A primary user of sector  $s_x$  may be a non-handoff user of sector  $s_x$  or a soft-handoff user of sector  $s_x$  whose serving sector is sector  $s_x$ . A secondary user of sector  $s_x$  is a soft-handoff user of sector  $s_x$  whose serving sector is another sector besides sector  $s_x$ .

[00056] FIG. 5 shows a block diagram of an embodiment of RX data processor 420 within base station 110x in FIG. 4A for a synchronous OFDMA system. In this embodiment, RX data processor 420 includes P data processors 510a through 510p for P primary users, an interference estimator 520, an interference canceller 530, and S data processors 540a through 540s for S secondary users, where  $P \geq 1$  and  $S \geq 1$ .

[00057] For each OFDM symbol period, OFDM demodulator 416 provides N received symbols for the N subbands to data processors 510a through 510p and interference canceller 530. One data processor 510 is assigned to recover the data transmission from each primary user. The processing by data processor 510a for a data transmission from primary user 1 is described below. Primary user 1 is assigned traffic channel  $p1$ , which is associated with FH sequence  $p1$ .

[00058] Within data processor 510a, an RX FH switch 514a receives the N received symbols for the N subbands in each OFDM symbol period. RX FH switch 514a provides received data symbols for traffic channel  $p1$  to a demodulator (Demod)/decoder 516a and received pilot symbols for primary user 1 to a channel estimator 518a. Since traffic channel  $p1$  dynamically hops from subband to subband, RX FH switch 514a operates in unison with TX FH switch 316 at the terminal for primary user  $p1$  to extract the received data symbols from the proper subbands for traffic channel  $p1$ . The FH sequence provided to RX FH switch 514a is the same FH sequence provided to TX FH switch 316 at the terminal for primary user 1. Moreover, the FH sequences are synchronized.

[00059] A channel estimator 518a obtains received pilot symbols for primary user 1 from RX FH switch 514a (as shown in FIG. 5) or from the received symbols. Channel estimator 518a then derives channel estimates for primary user 1 based on the received pilot symbols. The channel estimates may include estimates for (1) the channel gain between the terminal for primary user 1 and base station 110x for each subband used for

data transmission, (2) the signal strength of the pilot received from primary user 1, and (3) possibly other measurements.

[00060] Demodulator/decoder 516a may coherently demodulate the received data symbols from RX FH switch 514a with the channel estimates from channel estimator 518a to obtain data symbol estimates for primary user 1. Demodulator/decoder 516a further demodulates (i.e., symbol demaps), deinterleaves, and decodes the data symbol estimates to obtain decoded traffic data for primary user 1. In general, the processing performed by the units within base station 110x for primary user 1 is complementary to the processing performed by the corresponding units in the terminal for this primary user.

[00061] Data processors 510a through 510p provide decoded traffic data and channel estimates for primary users 1 through P, respectively. Interference estimator 520 receives the decoded traffic data and the channel estimates for primary users 1 through P, estimates the interference due to each of the P primary users, and provides interference estimates for the P primary users to interference canceller 530. Interference canceller 530 receives the N received symbols for the N subbands in each OFDM symbol period and the interference estimates for the P primary users. For each OFDM symbol period, interference canceller 530 determines the total interference due to the P primary users on each of the N subbands, subtracts the total interference from the received symbol for each subband, and provides N interference-canceled symbols for the N subbands. An exemplary design for interference estimator 520 and interference canceller 530 is described below.

[00062] One data processor 540 is assigned to recover the data transmission from each secondary user. Each data processor 540 includes an RX FH switch 544, a demodulator/decoder 546, and a channel estimator 548, which operate in similar manner as RX FH switch 514, demodulator/decoder 516, and channel estimator 518, respectively, within data processor 510. However, RX FH switch 544 within each data processor 540 is provided with the N interference-canceled symbols instead of the N received symbols for the N subbands. Moreover, RX FH switch 544 within each data processor 540 operates in unison with the TX FH switch at the terminal for the secondary user being recovered by that data processor. Data processors 540a through 540s provide decoded traffic data (and possibly channel estimates) for secondary users 1 through S, respectively.

[00063] FIG. 6 shows a block diagram of an embodiment of interference estimator 520 and interference canceller 530 within RX data processor 420 in FIG. 4A for a synchronous OFDMA system. In this embodiment, interference estimator 520 includes P per-terminal interference estimators 620a through 620p for P primary users. One per-terminal interference estimator 620 is assigned to estimate the interference due to each primary user. The processing by per-terminal interference estimator 620a to estimate the interference due to primary user 1 is described below.

[00064] Within per-terminal interference estimator 620a, an encoder/modulator 622a receives the decoded traffic data for primary user 1. Encoder/modulator 622a then encodes, interleaves, and modulates the decoded traffic data and provides data symbols. A TX FH switch 624a receives the data symbols from encoder/modulator 622a and provides these symbols onto the proper subbands for traffic channel  $p1$  assigned to primary user 1, as indicated by FH sequence  $p1$  associated with this traffic channel. TX FH switch 624a may also provide pilot symbols on the proper subbands. TX FH switch 624a provides N transmit symbols for the N subbands in each OFDM symbol period. In general, the processing by encoder/modulator 622a and TX FH switch 624a is the same as that performed by encoder/modulator 314 and TX FH switch 316, respectively, at the terminal for primary user 1.

[00065] A channel simulator 628a simulates the effects of the communication link between base station 110x and the terminal for primary user 1. Channel simulator 628a receives the transmit symbols from TX FH switch 624a and the channel estimates for primary user 1. Channel simulator 628a then processes the transmit symbols with the channel estimates to obtain an estimate of the interference due to primary user 1. For example, channel simulator 628a may multiply the transmit symbol on each subband with a channel gain estimate for that subband to obtain an interference component on that subband due to primary user 1.

[00066] The received symbols contain signal components for the symbols transmitted by the primary users and the secondary users of sector  $s_x$ . The interference estimate from channel simulator 628a is the signal component for the symbols transmitted by primary user 1. The interference estimate includes N interference components for the N subbands, where the interference component for any given subband may be zero if no data or pilot symbol is transmitted on that subband by primary user 1.

[00067] Per-terminal interference estimators 620a through 620p process the decoded traffic data for primary users 1 through P, respectively. Channel simulators 628a through 628p within per-terminal interference estimators 620a through 620p provide the interference estimates for primary users 1 through P, respectively.

[00068] Interference canceller 530 includes N P-input summers 630a through 630n and N 2-input summers 632a through 632n, i.e., one set of summers 630 and 632 for each of the N subbands. Interference canceller 530 receives the N received symbols for the N subbands from OFDM demodulator 416 and the interference estimates for primary users 1 through P from per-terminal interference estimators 620a through 620p, respectively. Within interference canceller 530, summer 630a receives and sums the interference components on subband 1 due to the P primary users and provides the total interference on subband 1. Each of the other N-1 summers 630 for subbands 2 through N similarly receives and sums the interference components on the associated subband due to the P primary users and provides the total interference on that subband. Summer 632a receives and subtracts the total interference on subband 1 from the received symbol for subband 1 and provides the interference-canceled symbol for subband 1. Each of the other N-1 summers 632 for subbands 2 through N similarly receives and subtracts the total interference on the associated subband from the received symbol for that subband and provides the interference-canceled symbol for that subband. Summers 632a through 632n provide the N interference-canceled symbols for the N subbands for each OFDM symbol period.

[00069] FIG. 7 shows a block diagram of an embodiment of OFDM demodulator/RX data processor 440 within base station 110y in FIG. 4B for an asynchronous OFDMA system. In this embodiment, OFDM demodulator/RX data processor 440 includes P data processors 710a through 710p for P primary users, an interference estimator 720, an interference canceller 730, and S data processors 740a through 740s for S secondary users, where  $P \geq 1$  and  $S \geq 1$ .

[00070] The recovered symbols from receiver unit 414 are provided to each of data processors 710a through 710p. Each data processor 710 includes an OFDM demodulator 712, an RX FH switch 714, a demodulator/decoder 716, and a channel estimator 718. OFDM demodulator 712 within each data processor 710 performs OFDM demodulation on the received symbols based on the timing of the primary user assigned to that data processor and provides symbol estimates for the N subbands. RX

FH switch 714, demodulator/ decoder 716, and channel estimator 718 then operate on the symbol estimates in similar manner as described above in FIG. 5 for RX FH switch 514, demodulator/decoder 516, and channel estimator 518, respectively. Each data processor 740 also includes an OFDM demodulator 742 that performs OFDM demodulation on the interference-canceled symbols based on the timing of the secondary user assigned to that data processor.

[00071] FIG. 8 shows a block diagram of an embodiment of interference estimator 720 and interference canceller 730 within OFDM demodulator/RX data processor 440 in FIG. 4B for an asynchronous OFDMA system. In this embodiment, interference estimator 720 includes P per-terminal interference estimators 820a through 820p for P primary users. One per-terminal interference estimator 820 is assigned to estimate the interference due to each primary user. Each per-terminal interference estimator 820 includes an encoder/modulator 822, a TX FH switch 824, an OFDM modulator 826, and a channel simulator 828. Encoder/modulator 822 and TX FH switch 824 operate as described above in FIG. 6 for encoder/modulator 622 and TX FH switch 624, respectively. TX FH switch 824 provides N transmit symbols for the N subbands in each OFDM symbol period. OFDM modulator 826 then performs OFDM modulation on the N transmit symbols for each OFDM symbol period and provides time-domain symbols.

[00072] Channel simulator 828 then processes the time-domain symbols with the channel estimates for the assigned primary user to obtain an estimate of the interference due to the primary user. Since different primary users may be associated with different timing for an asynchronous system, channel simulator 828 also performs sample rate conversion so that the interference estimate from the channel simulator is time-aligned with the received symbols.

[00073] Interference canceller 730 includes a P-input summer 830 and a 2-input summer 832. Interference canceller 730 receives the received symbols from receiver unit 414 and the interference estimates for primary users 1 through P from per-terminal interference estimators 820a through 820p, respectively. Within interference canceller 730, summer 830 sums the interference due to the P primary users and provides the total interference. Summer 832 subtracts the total interference from the received symbols and provides the interference-canceled symbols, which are processed by data processors 740a through 740s for the S secondary users.

[00074] The embodiment shown in FIGS. 5 and 6 suggests that the interference due to all P primary users is estimated and canceled prior to recovering the data transmissions from the S secondary users. A primary user of sector  $s_x$  may be a soft-handoff user who is power-controlled by multiple sectors in that user's active set. Base station 110x for sector  $s_x$  may not be able to decode the data transmission from this primary user if it is power-controlled such that it can be recovered by other sector(s) in the active set. If the data transmission from any primary user cannot be decoded, then base station 110x may not attempt to estimate and cancel the interference due to that primary user. A base station may use partially decoded data to cancel some of the interference.

[00075] The description above for FIGS. 5 and 6 also applies to an embodiment whereby a primary user of sector  $s_x$  is a non-handoff user of sector  $s_x$ , and a secondary user of sector  $s_x$  is a soft-handoff user of sector  $s_x$  (regardless of the serving sector for the soft-handoff user).

[00076] For the embodiment shown in FIGS. 5 and 6, the primary users are decoded first and the secondary users are decoded next, after the interference due to the primary users have been estimated and canceled. It may also be possible to decode the secondary users first and then the primary users next, after the interference due to the secondary users have been estimated and canceled. In general, the data transmissions from users may be decoded in any order by base station 110x. The interference due to each successfully decoded user may be estimated and canceled to improve the signal quality of remaining, not yet decoded users. However, system implementation may be simplified if non-handoff users are power-controlled such that they can be successfully decoded in the presence of interference from soft-handoff users. In this case, the non-handoff users are decoded first followed by the soft-handoff users.

[00077] For simplicity, FIGS. 5 and 6 show a parallel design whereby (1) one data processor 510 and one per-terminal interference estimator 620 is provided for each primary user and (2) one data processor 540 is provided for each secondary user. A time division multiplex (TDM) design may also be used whereby one data processor 510 is provided and time-shared for all primary and secondary users and one per-terminal interference estimator 620 is also provided and time-shared for all primary users.

[00078] FIG. 9 shows a flow diagram of a process 900 for transmitting data in a wireless communication system (e.g., a frequency hopping OFDMA system). Process 900 may be performed by each terminal that is in soft handoff with multiple base stations for multiple sectors.

[00079] Initially, an assignment of a traffic channel is obtained from a first base station (step 912). For a frequency hopping OFDMA system, the assigned traffic channel is associated with an FH sequence that indicates the specific subband to use for data transmission in each time interval (i.e., each hop period). Data is encoded and modulated to obtain data symbols (step 914). For a frequency hopping OFDMA system, the data symbols are provided on the subbands indicated by the FH sequence (step 916). The data symbols are further processed (e.g., OFDM modulated) for transmission on the assigned traffic channel to the first base station and to a second base station (step 918).

[00080] Traffic channels assigned by the first base station are orthogonal to one another and are not orthogonal to traffic channels assigned by the second base station. For a frequency hopping OFDMA system, the traffic channels assigned by the first and second base stations are each associated with a respective FH sequence. The FH sequences for the traffic channels assigned by the first base station are orthogonal to one another and are not orthogonal to the FH sequences for the traffic channels assigned by the second base station.

[00081] FIG. 10 shows a flow diagram of a process 1000 for receiving data transmissions from multiple terminals in a wireless communication system (e.g., a frequency hopping OFDMA system). Process 1000 may be performed by the base station for each sector. For clarity, the processing by base station  $x$  for sector  $s_x$  is described below.

[00082] Initially, received symbols are obtained (step 1012). The received symbols include (1) at least one data transmission on at least one "primary" traffic channel from at least one primary terminal and (2) at least one data transmission on at least one "secondary" traffic channel from at least one secondary terminal. Primary traffic channels are those assigned by base station  $x$ , and secondary traffic channels are those assigned by other base stations (e.g., neighboring base stations of base station  $x$ ). The primary traffic channels are orthogonal to one another and are not orthogonal to the secondary traffic channels. The primary traffic channels may be pseudo-random with

respect to the secondary traffic channels. Primary terminals are those assigned primary traffic channels by base station  $x$ , and secondary terminals are those assigned secondary traffic channels by other base stations. Each secondary terminal may be in soft handoff with at least two base stations (which include base station  $x$ ) and may be assigned a secondary traffic channel by another base station other than base station  $x$ .

[00083] For an OFDMA system, the received symbols are obtained for  $N$  subbands from an OFDM demodulator. Also for an OFDMA system, each traffic channel is associated with a respective FH sequence. The "primary" FH sequences for the primary traffic channels are orthogonal to one another and are not orthogonal to "secondary" FH sequences for the secondary traffic channels.

[00084] The received symbols are processed to obtain decoded data for each primary terminal (step 1014). Interference due to the primary terminal(s) is estimated (step 1016) and canceled from the received symbols to obtain interference-canceled symbols (step 1018). The interference-canceled symbols are then processed to obtain decoded data for each secondary terminal (step 1020).

[00085] The processing for each primary terminal may include (1) obtaining the received symbols on the subbands indicated by the primary FH sequence for the primary traffic channel assigned to the primary terminal, (2) deriving channel estimates for the primary terminal (e.g., based on pilot symbols received from the primary terminal), and (3) demodulating and decoding the received symbols for the primary terminal (e.g., with the channel estimates for the primary terminal) to obtain the decoded data for the primary terminal. The processing for each secondary terminal may be performed in similar manner, albeit on the interference-canceled symbols instead of the received symbols.

[00086] The interference due to each primary terminal may be estimated by (1) encoding and modulating the decoded data for the primary terminal to obtain data symbols, (2) providing the data symbols on the subbands indicated by the FH sequence assigned to the primary terminal, and (3) processing the data symbols with the channel estimates to obtain the interference due to the primary terminal. The interference due to each primary terminal may be combined to obtain total interference due to the primary terminal(s).

[00087] The techniques described herein may be used for a frequency hopping OFDMA system as well as other types of wireless communication systems. For

example, these techniques may be used for systems that employ other multi-carrier modulation techniques, such as discrete multi-tone (DMT). These techniques may also be used for wireless communication systems that do not employ multi-carrier modulation and those that do not employ frequency hopping.

[00088] The techniques described herein may be used for systems that define traffic channels in some other manners. For a frequency hopping OFDMA system, a traffic channel is defined by an associated FH sequence, which indicates the specific subband to use in each hop period. For a time division multiplex (TDM) system, data may be transmitted in time slots, and multiple traffic channels may be assigned different time slots. The traffic channels for each sector may be defined to be orthogonal to one another so that no two traffic channels use the same time slot. The traffic channels for different sectors may be pseudo-random so that a traffic channel for one sector may use the same time slot as (and thus collide with) a traffic channel for another sector. The techniques described herein may also be used for this TDM system. Each soft-handoff user is assigned one traffic channel by its serving sector. Each sector would recover the data transmissions from the primary users of that sector, cancel the interference due to the primary users, and then recover the data transmissions from the secondary users of that sector.

[00089] The techniques described herein may be used to support soft handoff on the reverse link, as described above. These techniques may also be used to support softer handoff, which is a process whereby a terminal communicates with multiple sectors of the same cell. The same processing may be performed at the base station and the terminal for both soft handoff and softer handoff.

[00090] The techniques described herein may also be used for the forward link. For example, a terminal may simultaneously receive a user-specific data transmission from one base station and overhead transmissions (e.g., broadcast transmissions) from multiple base stations on the forward link. The terminal may process its received signal to recover the user-specific data transmission from the one base station, estimate and cancel the interference due to the user-specific data transmission, and process the interference-canceled signal to recover the overhead transmissions from the multiple base stations.

[00091] The techniques described herein may be implemented by various means. For example, these techniques may be implemented in hardware, software, or a combination

thereof. For a hardware implementation, the processing units (e.g., data processors 510 and 540, interference estimator 520, interference canceller 530, and so on) within a base station may be implemented within one or more application specific integrated circuits (ASICs), digital signal processors (DSPs), digital signal processing devices (DSPDs), programmable logic devices (PLDs), field programmable gate arrays (FPGAs), processors, controllers, micro-controllers, microprocessors, other electronic units designed to perform the functions described herein, or a combination thereof. The processing units (e.g., encoder/modulator 314, TX FH switch 316, OFDM modulator 318, and so on) within a terminal may also be implemented within one or more ASICs, DSPs, and so on.

**[00092]** For a software implementation, the techniques described herein may be implemented with modules (e.g., procedures, functions, and so on) that perform the functions described herein. The software codes may be stored in memory units (e.g., memory units 332 and 432 in FIGS. 3 and 4) and executed by processors (e.g., controllers 330 and 430). The memory unit may be implemented within the processor or external to the processor, in which case it can be communicatively coupled to the processor via various means as is known in the art.

**[00093]** The previous description of the disclosed embodiments is provided to enable any person skilled in the art to make or use the present invention. Various modifications to these embodiments will be readily apparent to those skilled in the art, and the generic principles defined herein may be applied to other embodiments without departing from the spirit or scope of the invention. Thus, the present invention is not intended to be limited to the embodiments shown herein but is to be accorded the widest scope consistent with the principles and novel features disclosed herein.

**[00094] WHAT IS CLAIMED IS:**

## CLAIMS

1. A method of receiving data transmissions in a wireless communication system, comprising:

obtaining received symbols for at least one data transmission on at least one primary traffic channel from at least one primary terminal and at least one data transmission on at least one secondary traffic channel from at least one secondary terminal, wherein the at least one primary traffic channel is orthogonal to one another and is not orthogonal to the at least one secondary traffic channel;

processing the received symbols to obtain decoded data for each of the at least one primary terminal;

estimating interference due to the at least one primary terminal;

canceling the interference due to the at least one primary terminal from the received symbols to obtain interference-canceled symbols; and

processing the interference-canceled symbols to obtain decoded data for each of the at least one secondary terminal.

2. The method of claim 1, wherein the wireless communication system is a frequency hopping communication system.

3. The method of claim 2, wherein the at least one primary traffic channel and the at least one secondary traffic channel are each associated with a respective frequency hopping (FH) sequence that indicates a specific one of a plurality of subbands to use for data transmission in each time interval.

4. The method of claim 1, wherein the wireless communication system is a synchronous system.

5. The method of claim 1, wherein the wireless communication system is an asynchronous system.

6. A method of receiving data transmissions at a base station in a wireless frequency hopping (FH) communication system, comprising:

obtaining received symbols for a plurality of subbands;  
processing the received symbols to obtain decoded data for each of at least one primary terminal, wherein the at least one primary terminal is assigned at least one primary FH sequence to use for data transmission, and wherein the at least one primary FH sequence is orthogonal to one another;  
estimating interference due to the at least one primary terminal;  
canceling the interference due to the at least one primary terminal from the received symbols to obtain interference-canceled symbols; and  
processing the interference-canceled symbols to obtain decoded data for each of at least one secondary terminal, wherein the at least one secondary terminal is assigned at least one secondary FH sequence to use for data transmission, and wherein the at least one secondary FH sequence is not orthogonal to the at least one primary FH sequence.

7. The method of claim 6, wherein the at least one primary terminal is assigned the at least one primary FH sequence by the base station, and wherein the at least one secondary terminal is assigned the at least one secondary FH sequence by neighboring base stations of the base station.

8. The method of claim 6, wherein each of the at least one secondary terminal is in soft handoff with at least two base stations that include the base station.

9. The method of claim 8, wherein a first secondary terminal among the at least one secondary terminal is in soft handoff with at least two base stations for at least two different sectors of one cell in the system.

10. The method of claim 8, wherein a first secondary terminal among the at least one secondary terminal is in soft handoff with at least two base stations for at least two different cells in the system.

11. The method of claim 8, wherein each of the at least one secondary terminal is assigned a secondary FH sequence by one of the at least two base stations other than the base station.

12. The method of claim 6, wherein the at least one primary terminal include terminals not in soft handoff and communicating with only the base station.

13. The method of claim 12, wherein the at least one primary terminal further include terminals in soft handoff and assigned FH sequences by the base station.

14. The method of claim 6, wherein the at least one primary FH sequence is pseudo-random with respect to the at least one secondary FH sequence.

15. The method of claim 6, wherein the processing the received symbols includes

for each of the at least one primary terminal,

obtaining received symbols on subbands indicated by a primary FH sequence assigned to the primary terminal,

deriving channel estimates for the primary terminal, and

demodulating and decoding the received symbols for the primary terminal to obtain the decoded data for the primary terminal.

16. The method of claim 6, wherein the estimating includes for each of the at least one primary terminal,

encoding and modulating the decoded data for the primary terminal to obtain data symbols for the primary terminal,

providing the data symbols for the primary terminal on subbands indicated by a primary FH sequence assigned to the primary terminal, and

processing the data symbols for the primary terminal with channel estimates for the primary terminal to obtain interference due to the primary terminal, and

combining the interference due to each of the at least one primary terminal to obtain the interference due to the at least one primary terminal.

17. The method of claim 6, wherein the processing the interference-canceled symbols includes

for each of the at least one secondary terminal,

obtaining interference-canceled symbols on subbands indicated by a secondary FH sequence assigned to the secondary terminal, and demodulating and decoding the interference-canceled symbols for the secondary terminal to obtain the decoded data for the secondary terminal.

18. The method of claim 6, wherein the wireless communication system is an orthogonal frequency division multiple access (OFDMA) communication system.

19. An apparatus in a wireless frequency hopping (FH) communication system, comprising:

means for obtaining received symbols for a plurality of subbands;

means for processing the received symbols to obtain decoded data for each of at least one primary terminal, wherein the at least one primary terminal is assigned at least one primary FH sequence to use for data transmission, and wherein the at least one primary FH sequence is orthogonal to one another;

means for estimating interference due to the at least one primary terminal;

means for canceling the interference due to the at least one primary terminal from the received symbols to obtain interference-canceled symbols; and

means for processing the interference-canceled symbols to obtain decoded data for each of at least one secondary terminal, wherein the at least one secondary terminal is assigned at least one secondary FH sequence to use for data transmission, and wherein the at least one secondary FH sequence is not orthogonal to the at least one primary FH sequence

20. An apparatus in a wireless frequency hopping (FH) communication system, comprising:

at least one first data processor operative to process received symbols to obtain decoded data for each of at least one primary terminal, wherein the at least one primary terminal is assigned at least one primary FH sequence to use for data transmission, and wherein the at least one primary FH sequence is orthogonal to one another;

an interference estimator operative to estimate interference due to the at least one primary terminal;

an interference canceller operative to cancel the interference due to the at least one primary terminal from the received symbols to obtain interference-canceled symbols; and

at least one second data processor operative to process the interference-canceled symbols to obtain decoded data for each of at least one secondary terminal, wherein the at least one secondary terminal is assigned at least one secondary FH sequence to use for data transmission, and wherein the at least one secondary FH sequence is not orthogonal to the at least one primary FH sequence.

21. The apparatus of claim 20, wherein each of the at least one first data processor is assigned to a respective one of the at least one primary terminal, and wherein the first data processor for each primary terminal includes

a switch operative to obtain received symbols on subbands indicated by a primary FH sequence assigned to the primary terminal,

a channel estimator operative to derive channel estimates for the primary terminal, and

a demodulator and decoder operative to demodulate and decode the received symbols for the primary terminal to obtain the decoded data for the primary terminal.

22. The apparatus of claim 20, wherein the interference estimator includes at least one per-terminal interference estimator each operative to estimate interference due to a respective one of the at least one primary terminal, and wherein the per-terminal interference estimator for each primary terminal includes

an encoder and modulator operative to encode and modulate the decoded data for the primary terminal to obtain data symbols for the primary terminal,

a switch operative to provide the data symbols for the primary terminal on subbands indicated by a primary FH sequence assigned to the primary terminal, and

a channel simulator operative to process the data symbols for the primary terminal with channel estimates for the primary terminal to obtain the interference due to the primary terminal.

23. A processor readable media for storing instructions operable to:  
obtain received symbols for a plurality of subbands;

process the received symbols to obtain decoded data for each of at least one primary terminal, wherein the at least one primary terminal is assigned at least one primary frequency hopping (FH) sequence to use for data transmission, and wherein the at least one primary FH sequence is orthogonal to one another;

estimate interference due to the at least one primary terminal;

cancel the interference due to the at least one primary terminal from the received symbols to obtain interference-canceled symbols; and

process the interference-canceled symbols to obtain decoded data for each of at least one secondary terminal, wherein the at least one secondary terminal is assigned at least one secondary FH sequence to use for data transmission, and wherein the at least one secondary FH sequence is not orthogonal to the at least one primary FH sequence.

24. A method of transmitting data from a terminal in a wireless communication system, comprising:

obtaining an assignment of a traffic channel from a first base station;

encoding and modulating data to obtain data symbols; and

processing the data symbols for transmission on the traffic channel to the first base station and to a second base station, wherein traffic channels assigned by the first base station are orthogonal to one another and are not orthogonal to traffic channels assigned by the second base station.

25. The method of claim 24, wherein the transmission from the terminal is received, processed, and canceled by the first base station prior to recovering transmissions from other terminals assigned with other traffic channels not orthogonal to the traffic channel assigned to the terminal.

26. The method of claim 24, wherein transmissions from other terminals assigned with other traffic channels by the second base station are received, processed, and canceled by the second base station prior to recovering the transmission from the terminal.

27. The method of claim 24, wherein the wireless communication system is a frequency hopping communication system.

28. The method of claim 27, wherein the traffic channels assigned by the first base station and the traffic channels assigned by the second base station are each associated with a respective frequency hopping (FH) sequence that indicates a specific one of a plurality of subbands to use for data transmission in each time interval.

29. The method of claim 24, wherein the first and second base stations are for two different sectors of one cell in the system.

30. The method of claim 24, wherein the first and second base stations are for two different cells in the system.

31. A method of transmitting data in a wireless frequency hopping (FH) communication system, comprising:

- obtaining an assignment of an FH sequence from a first base station;
- encoding and modulating data to obtain data symbols;
- providing the data symbols on subbands indicated by the FH sequence; and
- processing the data symbols for transmission to the first base station and to a second base station, wherein FH sequences assigned by the first base station are orthogonal to one another and are not orthogonal to FH sequences assigned by the second base station.

32. The method of claim 31, wherein the FH sequences assigned by the first base station are pseudo-random with respect to the FH sequences assigned by the second base station.

33. An apparatus in a wireless frequency hopping (FH) communication system, comprising:

- means for obtaining an assignment of an FH sequence from a first base station;
- means for encoding and modulating data to obtain data symbols;
- means for providing the data symbols on subbands indicated by the FH sequence; and

means for processing the data symbols for transmission to the first base station and to a second base station, wherein FH sequences assigned by the first base station are orthogonal to one another and are not orthogonal to FH sequences assigned by the second base station.

34. An apparatus in a wireless frequency hopping (FH) communication system, comprising:

a controller operative to obtain an assignment of an FH sequence from a first base station;

an encoder and modulator operative to encode and modulate data to obtain data symbols;

a switch operative to provide the data symbols on subbands indicated by the FH sequence; and

an orthogonal frequency division multiplexing (OFDM) modulator operative to process the data symbols for transmission to the first base station and to a second base station, wherein FH sequences assigned by the first base station are orthogonal to one another and are not orthogonal to FH sequences assigned by the second base station.

35. A processor readable media for storing instructions operable to:

obtain an assignment of a frequency hopping (FH) sequence from a first base station;

encode and modulate data to obtain data symbols;

provide the data symbols on subbands indicated by the FH sequence; and

process the data symbols for transmission to the first base station and to a second base station, wherein FH sequences assigned by the first base station are orthogonal to one another and are not orthogonal to FH sequences assigned by the second base station.

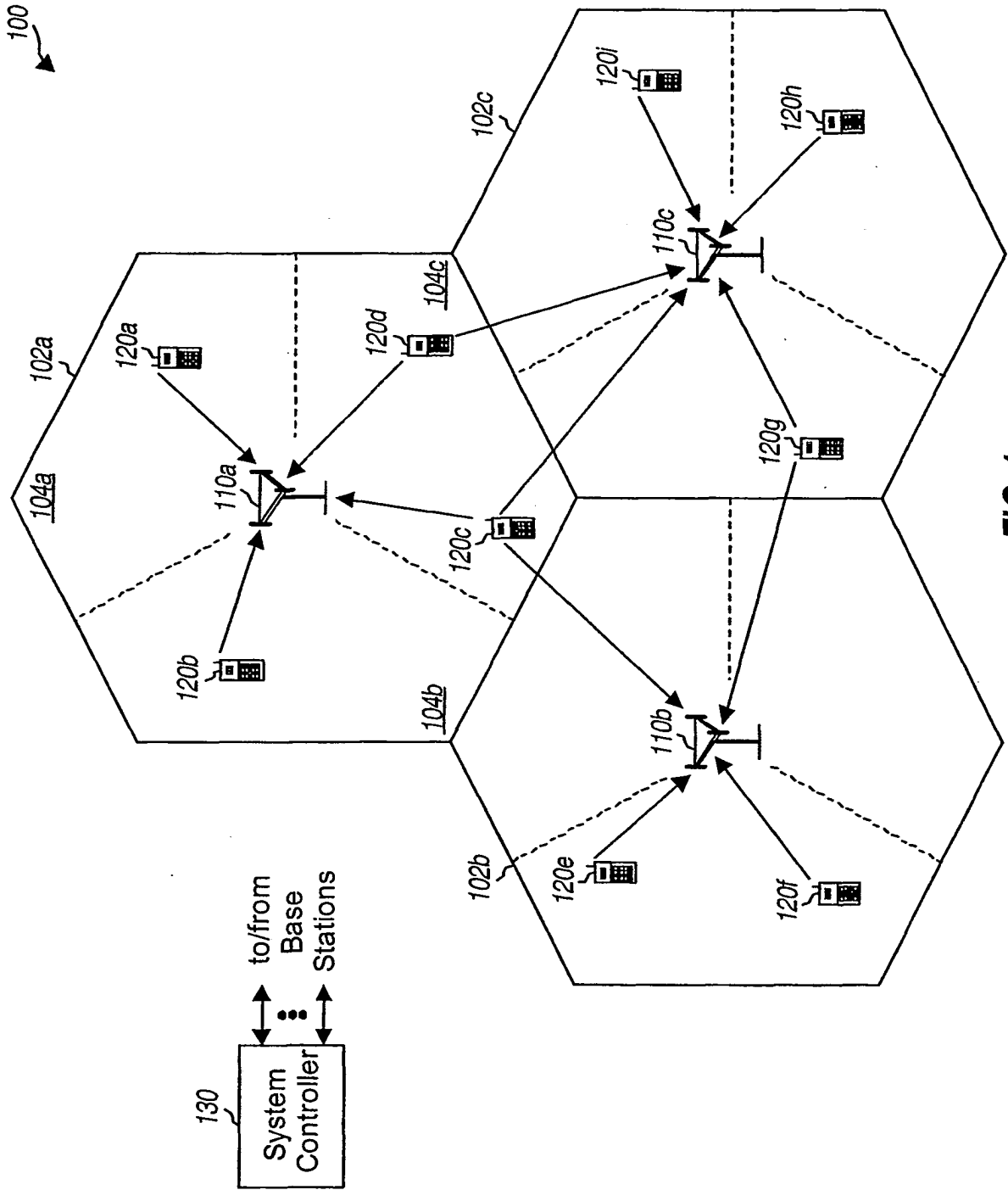

FIG. 1

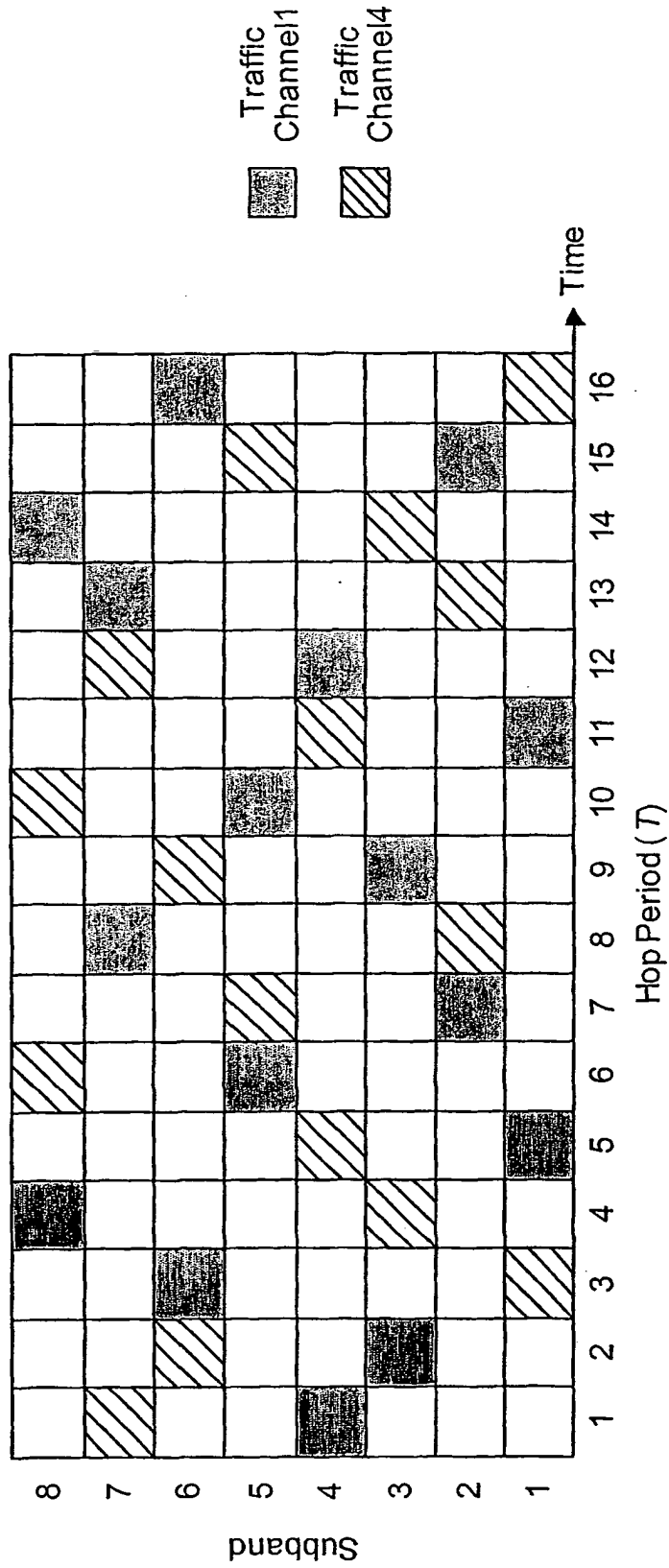
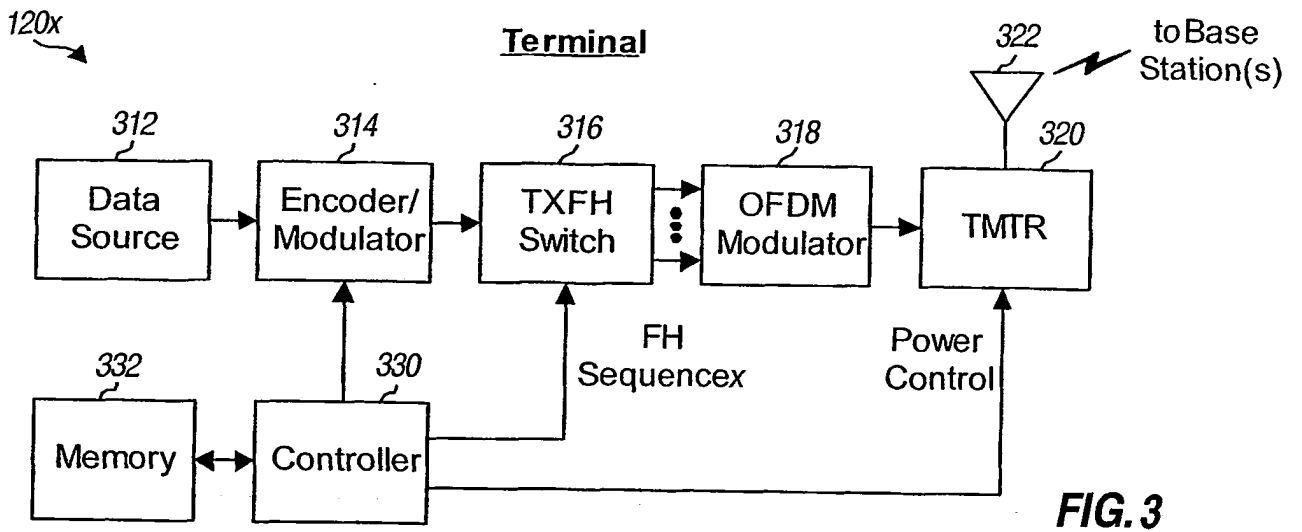
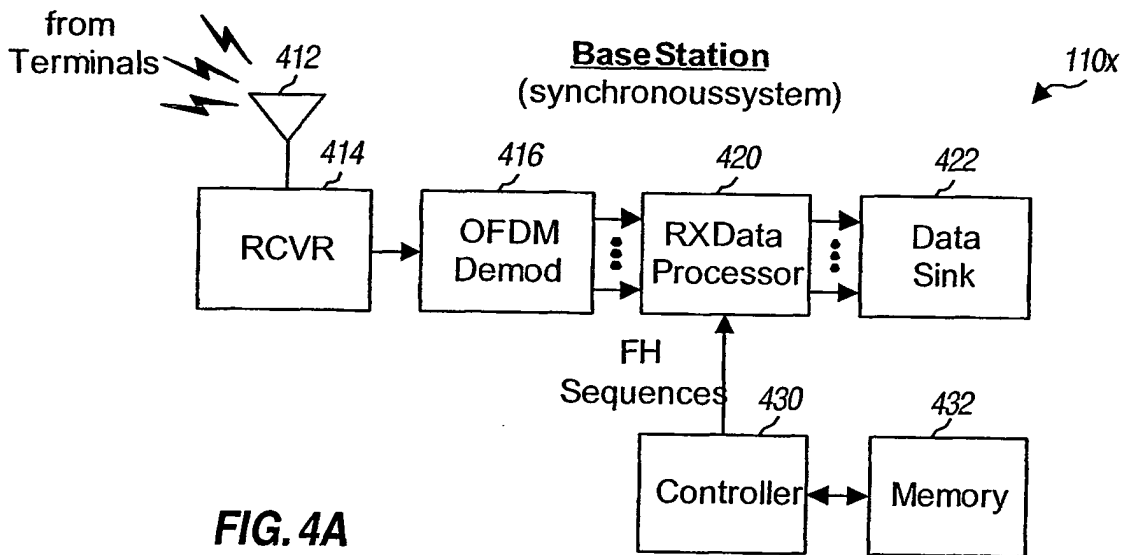

FIG. 2

3/8



**FIG. 3**



**FIG. 4A**

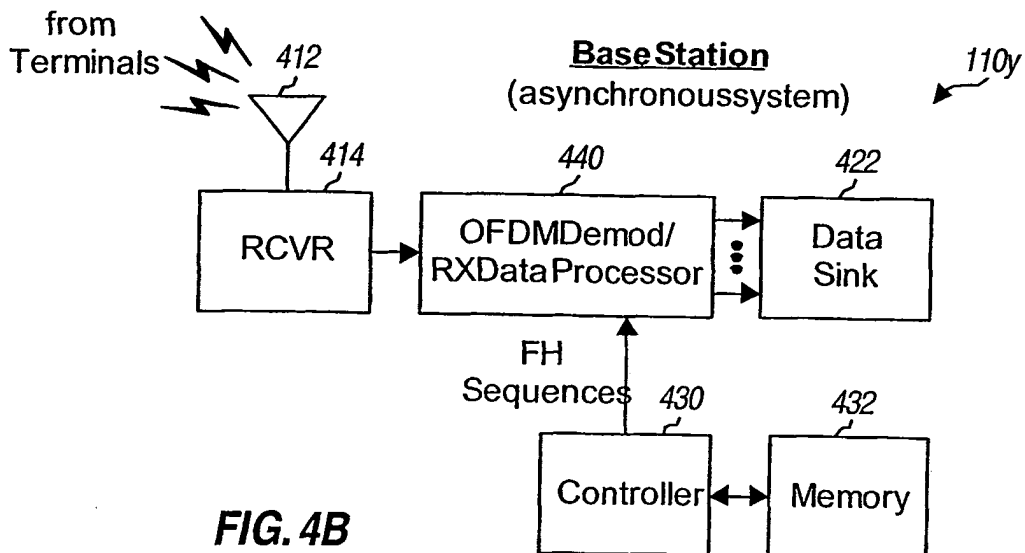

**FIG. 4B**

4/8

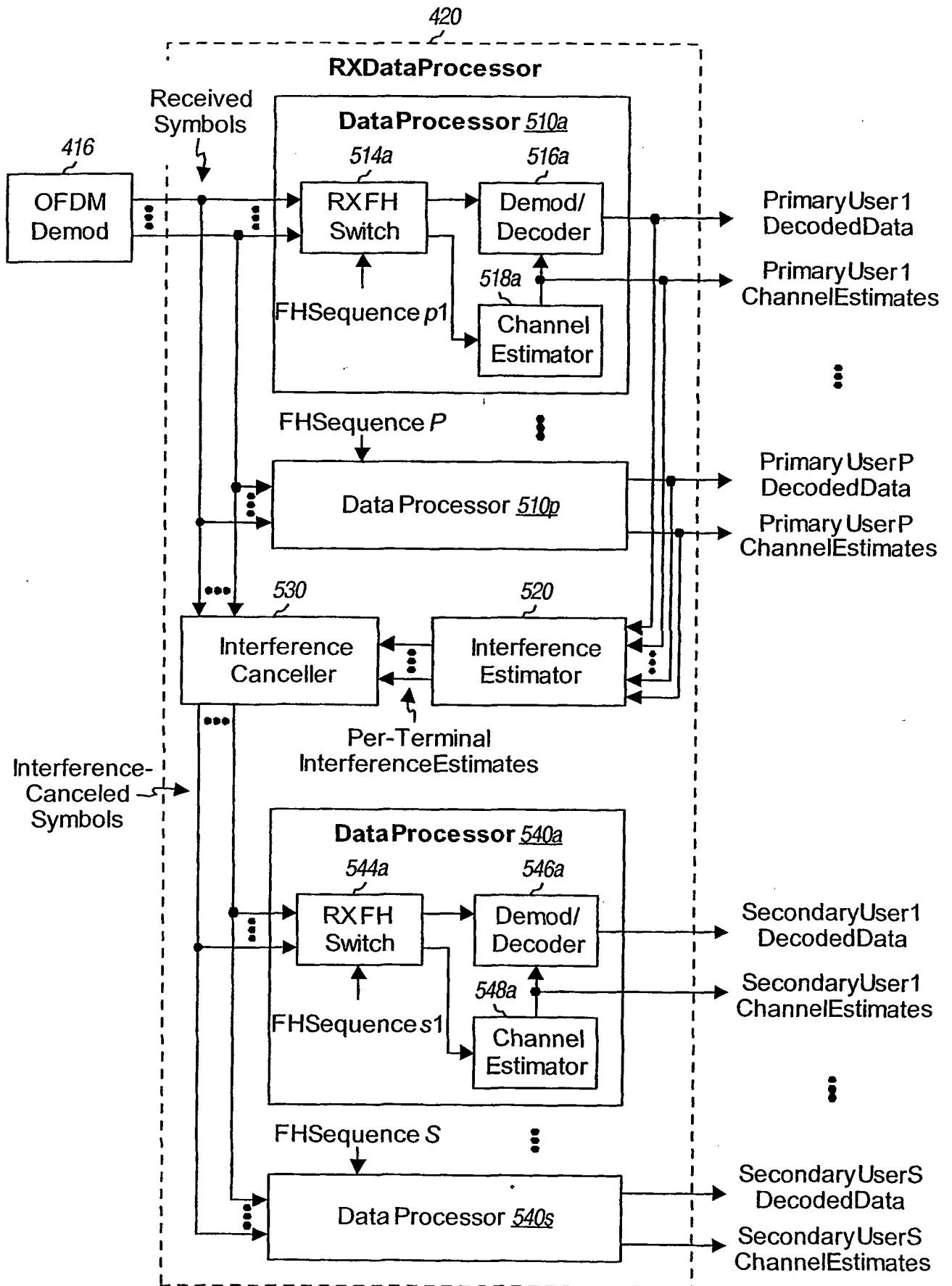

FIG. 5

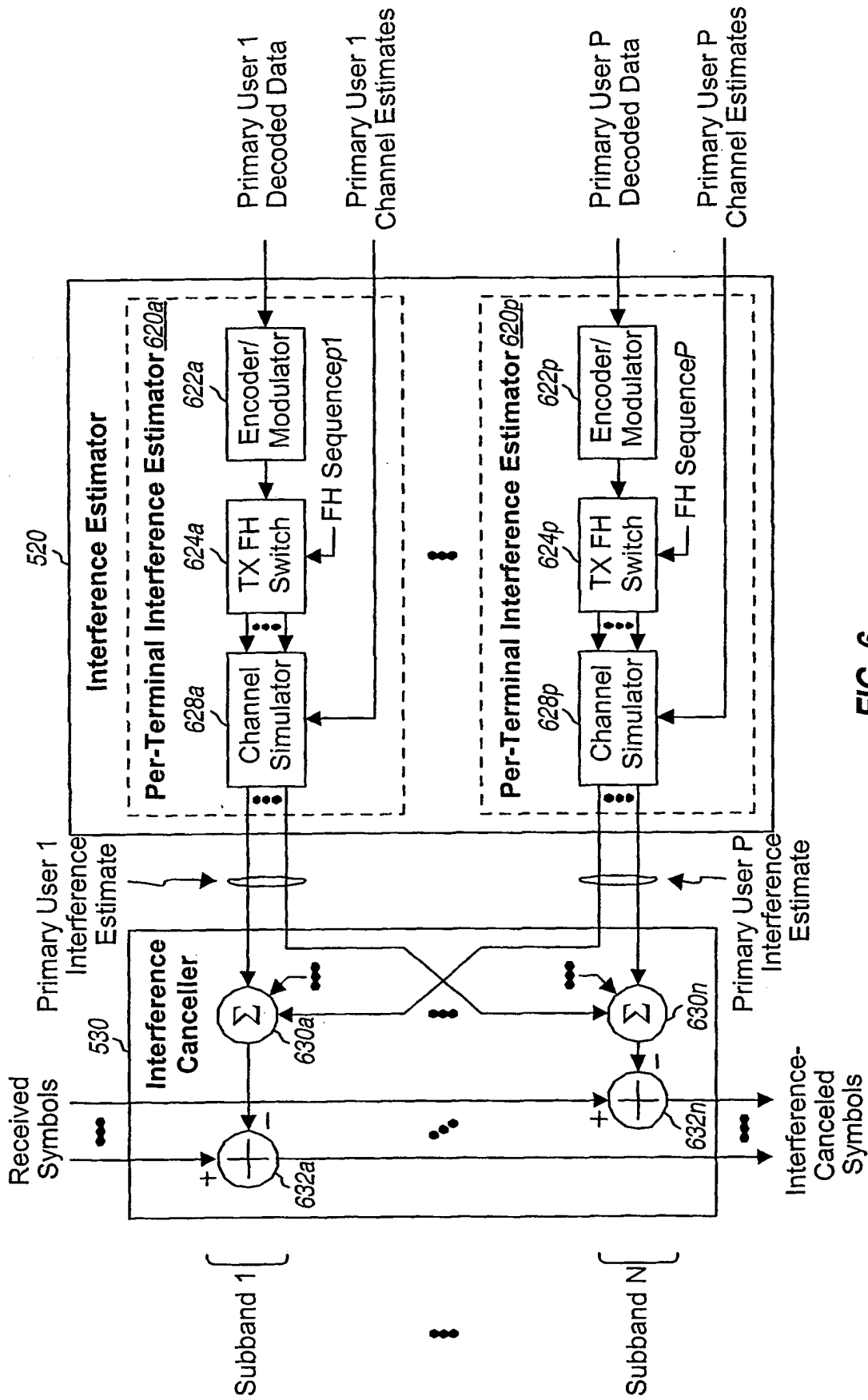

FIG. 6

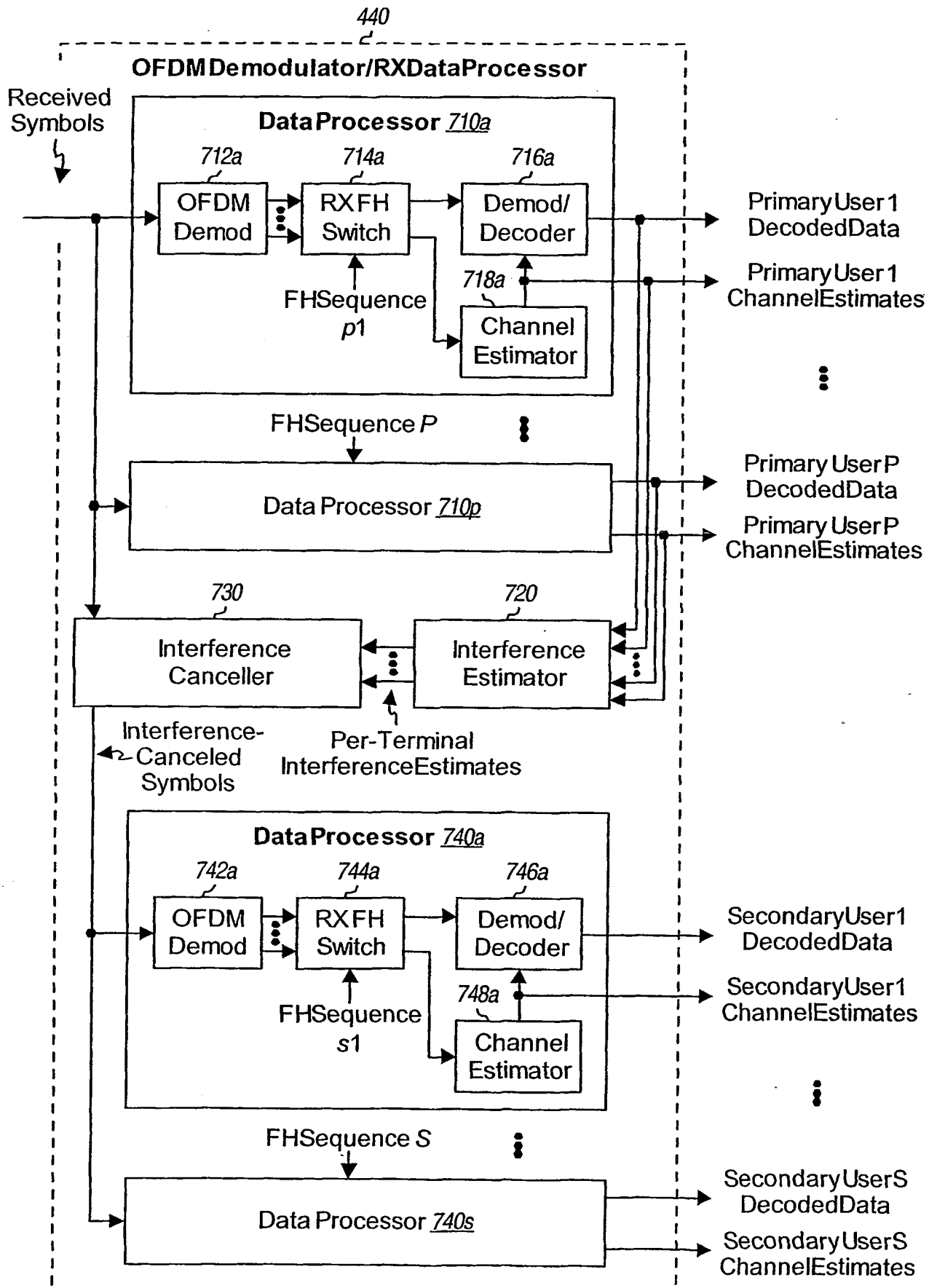

FIG. 7

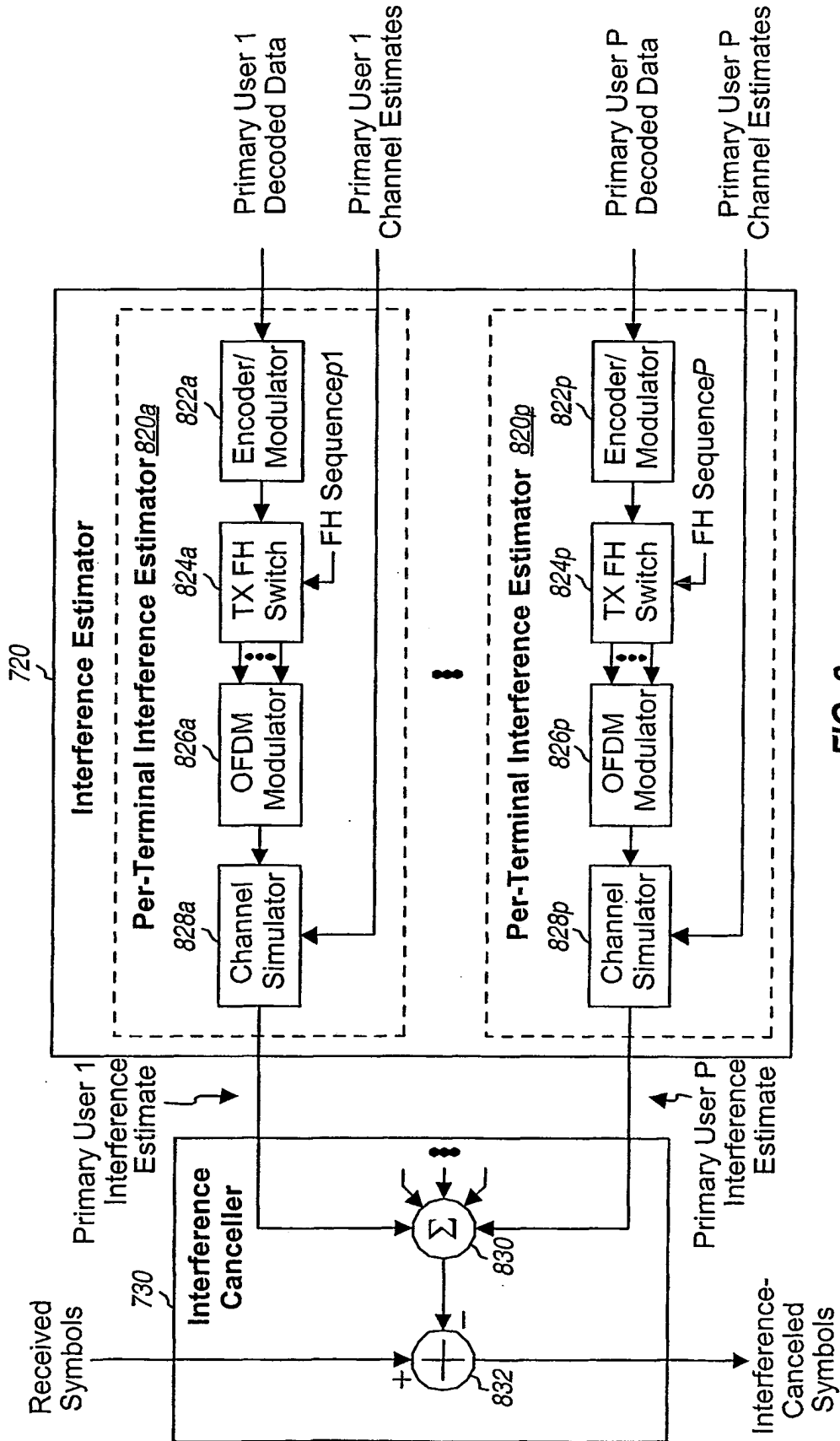

FIG. 8

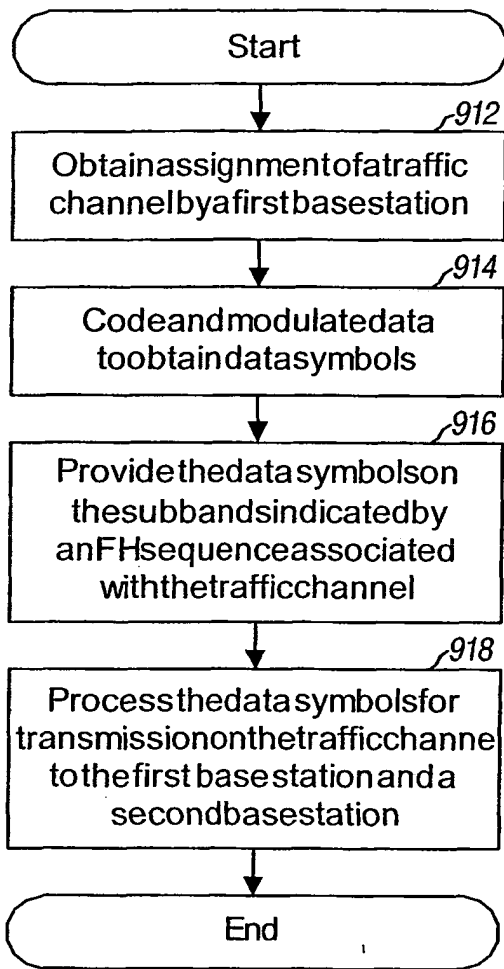

FIG. 9

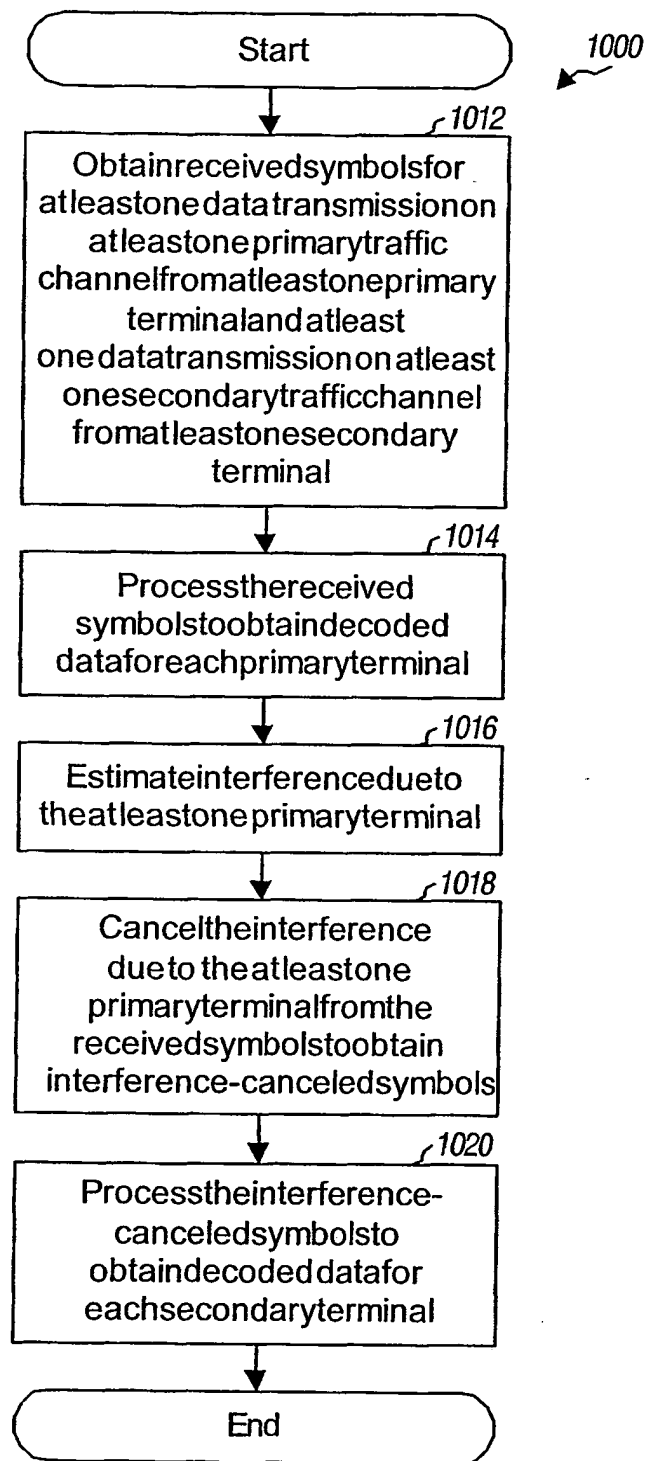

FIG. 10



[12] 发明专利申请公开说明书

[21] 申请号 200480012768.5

[43] 公开日 2006年11月29日

[11] 公开号 CN 1871784A

[22] 申请日 2004.5.7  
 [21] 申请号 200480012768.5  
 [30] 优先权  
     [32] 2003. 5. 12 [33] US [31] 60/470,160  
     [32] 2003. 7. 17 [33] US [31] 10/622,663  
 [86] 国际申请 PCT/US2004/014452 2004. 5. 7  
 [87] 国际公布 WO2004/102815 英 2004. 11. 25  
 [85] 进入国家阶段日期 2005. 11. 11  
 [71] 申请人 高通股份有限公司  
     地址 美国加利福尼亚  
 [72] 发明人 阿夫尼什·阿格拉瓦

[74] 专利代理机构 永新专利商标代理有限公司  
 代理人 王 英

权利要求书 8 页 说明书 18 页 附图 8 页

[54] 发明名称

无线跳频通信系统中使用干扰消除的软切换

[57] 摘要

提供了在跳频 OFDMA 系统中用于支持的软切换的技术。每个扇区同时支持“无切换”用户和“软切换”用户。无切换用户只使用一个扇区进行通信，而软切换用户同时使用多个扇区进行通信。无切换用户由它们的唯一扇区分配业务信道，而软切换用户由它们的“服务”扇区分配业务信道。对于每个扇区，分配给无切换用户的业务信道相互正交，并且，可以或可以不与分配给软切换用户的业务信道正交。每个扇区处理它的接收信号，并恢复来自该扇区的无切换用户的数据传输。然后，每个扇区估计由无切换用户引起的干扰，并将其从接收信号中消除。每个扇区进一步处理它的消除了干扰的信号，以恢复来自软切换用户的数据传输。

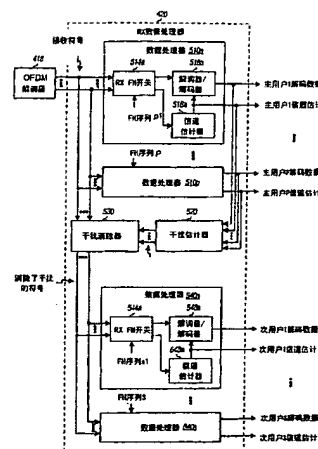

- 1、一种用于在无线通信系统中接收数据传输的方法，包括：  
获取来自至少一个主终端的至少一个主业务信道上的至少一个数据传输的接收符号和来自至少一个次终端的至少一个次业务信道上的至少一个数据传输的接收符号，其中，所述至少一个主业务信道相互正交，并且与所述至少一个次业务信道不正交；  
处理所述接收符号，以获取所述至少一个主终端中每一个主终端的解码数据；  
估计由所述至少一个主终端引起的干扰；  
从所述接收符号中消除由所述至少一个主终端引起的所述干扰，以获取消除了干扰的符号；以及  
处理所述消除了干扰的符号，以获取所述至少一个次终端中每一个次终端的解码数据。
- 2、如权利要求 1 所述的方法，其中，所述无线通信系统是跳频通信系统。
- 3、如权利要求 2 所述的方法，其中，所述至少一个主业务信道和所述至少一个次业务信道各自与相应的跳频（FH）序列相关联，所述 FH 序列表示在每个时间间隔内用于数据传输的多个子带中的一个具体子带。
- 4、如权利要求 1 所述的方法，其中，所述无线通信系统是同步系统。
- 5、如权利要求 1 所述的方法，其中，所述无线通信系统是异步系统。
- 6、一种用于在无线跳频（FH）通信系统中的基站处接收数据传

输的方法，包括：

获取多个子带的接收符号；

处理所述接收符号，以获取至少一个主终端中每一个主终端的解码数据，其中，用于数据传输的至少一个主 FH 序列被分配给所述至少一个主终端，并且其中，所述至少一个主 FH 序列相互正交；

估计由所述至少一个主终端引起的干扰；

从所述接收符号中消除由所述至少一个主终端引起的所述干扰，以获取消除了干扰的符号；以及

处理所述消除了干扰的符号，以获取至少一个次终端中每一个次终端的解码数据，其中，用于数据传输的至少一个次 FH 序列被分配给所述至少一个次终端，并且其中，所述至少一个次 FH 序列与所述至少一个主 FH 序列不正交。

7、如权利要求 6 所述的方法，其中，所述基站将所述至少一个主 FH 序列分配给所述至少一个主终端，并且其中，所述基站的相邻基站将所述至少一个次 FH 序列分配给所述至少一个次终端。

8、如权利要求 6 所述的方法，其中，所述至少一个次终端中的每一个次终端处于使用包括所述基站在内的至少两个基站进行软切换的状态。

9、如权利要求 8 所述的方法，其中，所述至少一个次终端中的第一次终端处于使用所述系统中一个小区的至少两个不同扇区的至少两个基站进行软切换的状态。

10、如权利要求 8 所述的方法，其中，所述至少一个次终端中的第一次终端处于使用所述系统中两个不同小区的至少两个基站进行软切换的状态。

11、如权利要求 8 所述的方法，其中，所述至少两个基站中不是

所述基站的一个基站为所述至少一个次终端中的每一个次终端分配一个次 FH 序列。

12、如权利要求 6 所述的方法，其中，所述至少一个主终端包括未处于软切换状态并且只用所述基站进行通信的终端。

13、如权利要求 12 所述的方法，其中，所述至少一个主终端还包括处于软切换状态并且由所述基站分配了 FH 序列的终端。

14、如权利要求 6 所述的方法，其中，所述至少一个主 FH 序列相对于所述至少一个次 FH 序列是伪随机的。

15、如权利要求 6 所述的方法，其中，所述处理所述接收符号的步骤包括：

对于所述至少一个主终端中的每一个主终端，  
获取由分配给所述主终端的主 FH 序列所指示的子带上的接收符号；  
获取所述主终端的信道估计；以及  
对所述主终端的所述接收符号进行解调和解码，以获取所述主终端的解码数据。

16、如权利要求 6 所述的方法，其中，所述估计步骤包括：

对于所述至少一个主终端中的每一个主终端，  
对所述主终端的所述解码数据进行编码和调制，以获取所述主终端的数据符号；  
在由分配给所述主终端的主 FH 序列所指示的子带上提供所述主终端的所述数据符号；以及  
利用所述主终端的信道估计，处理所述主终端的所述数据符号，以获取由所述主终端引起的干扰；以及  
将由所述至少一个主终端中的各主终端引起的所述干扰进

行合并，以获取由所述至少一个主终端引起的所述干扰。

17、如权利要求 6 所述的方法，其中，所述处理所述消除了干扰的符号的步骤包括：

对于所述至少一个次终端中的每一个次终端，

获取由分配给所述次终端的次 FH 序列所指示的子带上的消除了干扰的符号；以及

对所述次终端的消除了干扰的符号进行解调和解码，以获取所述次终端的所述解码数据。

18、如权利要求 6 所述的方法，其中，所述无线通信系统是正交频分多址（OFDMA）通信系统。

19、无线跳频（FH）通信系统中的一种装置，包括：

获取模块，用于获取多个子带的接收符号；

用于处理所述接收符号的处理模块，以获取至少一个主终端中每一个主终端的解码数据，其中，用于数据传输的至少一个主 FH 序列被分配给所述至少一个主终端，并且其中，所述至少一个主 FH 序列相互正交；

估计模块，用于估计由所述至少一个主终端引起的干扰；

消除模块，用于从所述接收符号中消除由所述至少一个主终端引起的所述干扰，以获取消除了干扰的符号；以及

用于处理所述消除了干扰的符号的处理模块，以获取至少一个次终端中每一个次终端的解码数据，其中，用于数据传输的至少一个次 FH 序列被分配给所述至少一个次终端，并且其中，所述至少一个次 FH 序列与所述至少一个主 FH 序列不正交。

20、无线跳频（FH）通信系统中的一种装置，包括：

至少一个第一数据处理器，用于处理接收符号，以获取至少一个主终端中每一个主终端的解码数据，其中，用于数据传输的至少一个

主 FH 序列被分配给所述至少一个主终端，并且其中，所述至少一个主 FH 序列相互正交；

干扰估计器，用于估计由所述至少一个主终端引起的干扰；

干扰消除器，用于从所述接收符号中消除由所述至少一个主终端引起的所述干扰，以获取消除了干扰的符号；以及

至少一个第二数据处理器，用于处理所述消除了干扰的符号，以获取至少一个次终端中每一个次终端的解码数据，其中，用于数据传输的至少一个次 FH 序列被分配给所述至少一个次终端，并且其中，所述至少一个次 FH 序列与所述至少一个主 FH 序列不正交。

21、如权利要求 20 所述的装置，其中，将所述至少一个第一数据处理器中的每一个分配给所述至少一个主终端中的一个相应主终端，并且其中，每个主终端的所述第一数据处理器包括：

开关，用于获取由分配给所述主终端的主 FH 序列所指示的子带上的接收符号；

信道估计器，用于获取所述主终端的信道估计；以及

解调器与解码器，用于对所述主终端的所述接收符号进行解调和解码，以获取所述主终端的所述解码数据。

22、如权利要求 20 所述的装置，其中，所述干扰估计器包括至少一个每终端干扰估计器，所述每终端干扰估计器各自用于估计由所述至少一个主终端中的相应主终端引起的干扰，并且其中，每个主终端的所述每终端干扰估计器包括：

编码器与调制器，用于对所述主终端的所述解码数据进行编码和调制，以获取所述主终端的数据符号；

开关，用于在由分配给所述主终端的主 FH 序列所指示的子带上提供所述主终端的所述数据符号；以及

信道模拟器，用于利用所述主终端的信道估计，处理所述主终端的所述数据符号，以获取由所述主终端引起的所述干扰。

23、一种用于存储指令的处理器可读介质，所述指令用于：  
获取多个子带的接收符号；

处理所述接收符号，以获取至少一个主终端中每一个主终端的解码数据，其中，用于数据传输的至少一个主跳频（FH）序列被分配给所述至少一个主终端，并且其中，所述至少一个主 FH 序列相互正交；

估计由所述至少一个主终端引起的干扰；

从所述接收符号中消除由所述至少一个主终端引起的所述干扰，以获取消除了干扰的符号；以及

处理所述消除了干扰的符号，以获取至少一个次终端中每一个次终端的解码数据，其中，用于数据传输的至少一个次 FH 序列被分配给所述至少一个次终端，并且其中，所述至少一个次 FH 序列与所述至少一个主 FH 序列不正交。

24、一种在无线通信系统中从终端发送数据的方法，包括：

从第一基站获取业务信道的分配；

对数据进行编码和调制，以获取数据符号；以及

处理通过所述业务信道向所述第一基站和第二基站传输的所述数据符号，其中，由所述第一基站分配的业务信道相互正交，并且与由所述第二基站分配的业务信道不正交。

25、如权利要求 24 所述的方法，其中，在恢复来自其他终端的传输之前，所述第一基站接收、处理和消除来自所述终端的传输，其中与分配给所述终端的所述业务信道不正交的其他业务信道被分配给了所述其他终端。

26、如权利要求 24 所述的方法，其中，在恢复来自所述终端的传输之前，所述第二基站接收、处理和消除来自其他终端的传输，其中由所述第二基站给所述其他终端分配了其他业务信道。

27、如权利要求 24 所述的方法，其中，所述无线通信系统是跳频通信系统。

28、如权利要求 27 所述的方法，其中，由所述第一基站分配的业务信道和由所述第二基站分配的业务信道各自与相应的跳频（FH）序列相关联，所述 FH 序列指示在每个时间间隔内用于数据传输的多个子带中的一个具体子带。

29、如权利要求 24 所述的方法，其中，所述第一和第二基站用于所述系统中一个小区的两个不同扇区。

30、如权利要求 24 所述的方法，其中，所述第一和第二基站用于所述系统中的两个不同小区。

31、一种用于在无线跳频（FH）通信系统中发送数据的方法，包括：

从第一基站获取 FH 序列的分配；

对数据进行编码和调制，以获取数据符号；

在由所述 FH 序列所指示的子带上提供所述数据符号；以及

处理欲向所述第一基站和第二基站传输的所述数据符号，其中，由所述第一基站分配的 FH 序列相互正交，并且与由所述第二基站分配的 FH 序列不正交。

32、如权利要求 31 所述的方法，其中，由所述第一基站分配的 FH 序列相对于由所述第二基站分配的 FH 序列是伪随机的。

33、无线跳频（FH）通信系统中的一种装置，包括：

获取模块，用于从第一基站获取 FH 序列的分配；

编码与调制模块，用于对数据进行编码和调制，以获取数据符号；

提供模块，用于在由所述 FH 序列指示的子带上提供所述数据符

号；以及

处理模块，用于处理欲向所述第一基站和第二基站传输的所述数据符号，其中，由所述第一基站分配的 FH 序列相互正交，并且与由所述第二基站分配的 FH 序列不正交。

34、无线跳频（FH）通信系统中的一种装置，包括：

控制器，用于从第一基站获取 FH 序列的分配；

编码器与调制器，用于对数据进行编码和调制，以获取数据符号；

开关，用于在由所述 FH 序列指示的子带上提供所述数据符号；

以及

正交频分复用（OFDM）调制器，用于处理欲向所述第一基站和第二基站传输的所述数据符号，其中，由所述第一基站分配的 FH 序列相互正交，并且与由所述第二基站分配的 FH 序列不正交。

35、一种用于存储指令的处理器可读介质，所述指令用于：

从第一基站获取 FH 序列的分配；

对数据进行编码和调制，以获取数据符号；

在由所述 FH 序列指示的子带上提供所述数据符号；以及

处理欲向所述第一基站和第二基站传输的所述数据符号，其中，由所述第一基站分配的 FH 序列相互正交，并且与由所述第二基站分配的 FH 序列不正交。

## 无线跳频通信系统中使用干扰消除的软切换

### 相关申请的交叉参考

本申请涉及被全部转让给本申请受让人的下列申请：

2003年5月12日提交的、题为“Soft Handoff with Interference Cancellation in a Wireless Frequency Hopping Communication System”、共同待决的美国申请 No. 06/470160。

### 发明领域

本发明涉及通信，尤其涉及在无线跳频通信系统中利用干扰消除支持软切换的技术。

### 技术背景

在跳频通信系统中，数据在不同时间间隔内在不同子频带上传输，该时间间隔被称为“跳频周期”。正交频分复用（OFDM）、其他多载波调制技术或一些其他构想可以提供这些子频带。通过跳频，数据传输以伪随机的方式，在子带间跳跃。这种跳跃提供频率分集，并使数据传输能够更好地抵挡有害的路径效应，如窄带干扰、人为干扰、衰落等。

正交频分多址（OFDMA）系统使用 OFDM，能够同时支持多个用户。对于跳频 OFDMA 系统，可以在与一个具体跳频（FH）序列相关联的“业务”信道上发送特定用户的数据传输。该 FH 序列表示在每个跳频周期内用于数据传输的一个具体子带。在与不同 FH 序列相关联的多个业务信道上，可以同时发送多个用户的多个数据传输。可以将这些 FH 序列定义成相互正交，从而，只有一个业务信道、因此只有一个数据传输使用每个跳频周期中的每个子带。通过使用正交 FH 序列，多个数据传输相互之间不会干扰，同时享有频率分集的好处。

可将 OFDMA 系统部署为具有多个小区，其中，小区通常指基站的覆盖区域。一个小区中特定子带上的数据传输对于相邻小区中相同子带上的另一数据传输来说就是干扰。为了使小区间干扰随机化，通常将各小区的 FH 序列定义成相对于相邻小区的 FH 序列是伪随机的。通过使用不同小区的伪随机 FH 序列，实现干扰分集，并且，一个小区内一个用户的数据传输观测到来自其他小区中其他用户的数据传输的平均干扰。

在多小区 OFDMA 系统中，支持“软切换”是非常好的。在软切换过程中，用户同时使用多个基站进行通信。软切换可以提供空间分集，以防止经由向或来自不同位置的多个基站的数据传输的有害路径效应。但是，当系统采用跳频时，软切换很复杂。这是因为，为了使小区间干扰随机化，一个小区的 FH 序列相对于相邻小区的 FH 序列是伪随机的（即不正交的）。多个基站中的指定基站可以指示使用多个基站进行软切换的用户使用 FH 序列。该软切换用户发送的数据传输与该指定基站的其他用户发送的数据传输正交，但相对于其他基站的用户发送的数据传输却是伪随机的。该软切换用户将对其他基站的用户造成干扰，并且因此也将收到来自这些用户的干扰。干扰降低所有受干扰用户的性能，除非以某种方式将其降低。

因此，本领域中需要支持跳频 OFDMA 系统中的软切换的技术。

## 发明内容

这里提供的技术支持无线通信系统（例如，跳频 OFDMA 系统）中的软切换。可以将系统中的每个小区分成一个或多个扇区。系统中的每个扇区可以同时支持一组“无切换”用户和一组“软切换”用户。无切换用户是只使用一个扇区进行通信（即，未处于软切换状态）的用户。软切换用户是同时使用多个扇区进行通信的用户。

对于每个扇区，该扇区向该扇区的每个无切换用户分配业务信道，而每个软切换用户的“服务”或“主持人”扇区为该扇区的软切换用户分配业务信道。软切换用户的服务扇区是软切换用户进行通信所用的多个扇区中的指定扇区。对于每个扇区，分配给该扇区的无切

换用户的业务信道相互正交，并且可以或可以不与分配给该扇区的软切换用户的业务信道正交，这取决于该扇区是不是这些软切换用户的服务扇区。

对于每个扇区，可以对该扇区的无切换用户进行功率控制，从而，当存在来自该扇区的软切换用户的干扰以及存在来自其他扇区的用户的干扰时，该扇区可以接收它们的数据传输并对其进行解码。也可以对软切换用户进行功率控制，从而，它们的扇区能够对它们的数据传输进行解码，同时降低对无切换用户的干扰。

每个扇区处理它的接收信号，并恢复来自该扇区的无切换用户的数据传输。在将来自无切换用户的数据传输解码之后，每个扇区估计由该扇区的无切换用户引起的干扰，并从将其从接收信号中消除。每个扇区还处理它的消除了干扰的信号，从而恢复来自该扇区的软切换用户的数据传输。

下面详细描述本发明的各个方面和实施例。

## 附图简述

通过下面结合附图的详细描述，本发明的特征、本质和优点将变得更加显而易见，在这些附图中，相同的标记表示相应或相同的部件或步骤，其中：

图 1 示出了一种 OFDMA 系统；

图 2 示出了 OFDMA 系统中一个扇区的跳频；

图 3 是终端的框图；

图 4A 是同步系统中的基站的框图；

图 4B 是异步系统中的基站的框图；

图 5 是同步系统中的基站内的接收 (RX) 数据处理器框图；

图 6 是 RX 数据处理器内的干扰估计器和干扰消除器的框图；

图 7 是异步系统中的基站内的 OFDM 解调器/RX 数据处理器框图；

图 8 是 OFDM 解调器/RX 数据处理器内的干扰估计器和干扰消除器的框图；

图 9 是终端发送数据的流程图；以及  
图 10 是基站接收来自多个终端的数据传输的流程图。

### 具体实施方式

这里使用的“示例性的”一词意味着“用作例子、例证或说明”。这里被描述为“示例性”的任何实施例或设计不应被解释为比其他实施例或设计更优选或有优势。

图 1 示出了一种支持多个用户的示例性的 OFDMA 系统 100。系统 100 包括多个提供与多个终端 120 进行通信的基站 110。基站是用于与终端进行通信的固定站，也可被称为接入点、节点 B 或其他术语。终端 120 通常分散在系统中，每个终端可以是固定的或移动的。也可将终端称为移动站、用户设备 (UE)、无线通信装置或其他术语。

在任何给定时刻，每个终端可以通过前向链路与多个基站通信和/或通过反向链路与多个基站通信。这取决于该终端是不是激活的、是否支持软切换以及该终端是否处于软切换状态。前向链路（即下行链路）指的是从基站到终端的通信链路，而反向链路（即上行链路）指的是从终端到基站的通信链路。在图 1 中，终端 120c 在反向链路上处于使用基站 110a、110b 和 110c 进行软切换的状态，终端 120d 处于使用基站 110a 和 110c 进行软切换的状态，终端 120g 处于使用基站 110b 和 110c 进行软切换的状态。其余的终端未处于软切换状态。为简单起见，图 1 没有显示前向链路传输。

系统控制器 130 连接到基站 110，可以执行多种功能，如：(1) 协调和控制基站 110；(2) 在这些基站之间对数据进行寻径；以及 (3) 由这些基站服务的终端的接入和控制。

每个基站 110 提供一个相应地理区域 102 的覆盖范围。术语“小区 (cell)”可以指基站和/或其覆盖区域，这取决于使用该术语的上下文。为了增加容量，可将每个基站的覆盖区域分成多个扇区（例如，三个扇区 104a、104b 和 104c）。每个扇区由相应的基站收发机子系统 (BTS) 提供服务。术语“扇区”可以指 BTS 和/其覆盖区域，这取决于使用该术语的上下文。对于一个进行了分区的小区，该小区的基

站通常包括该小区的所有扇区的 BTS。下面的描述假设将每个小区分成多个扇区。为简单起见，在下面的描述中，术语“基站”通指为小区服务的固定站和为扇区服务的固定站。同一小区的所有扇区的基站通常实现在该小区的一个物理基站内。

这里描述的技术可用于支持软切换，在软切换中，终端同时使用多个小区进行通信。这些小区的基站包括在该终端的激活集（active set）中。这些技术也可用于支持“更软切换（softer handoff）”，在更软切换过程中，一个终端同时使用同一小区的多个扇区进行通信。这些扇区的基站（通常是同一物理基站的多个部分）包括在该终端的激活集中。为简单起见，在下面的描述中，术语“软切换”通常指终端同时使用多个小区进行通信的情况以及终端同时使用同一小区的多个扇区进行通信的情况。

这里描述的技术可用于同步系统，在同步系统中，系统中多个基站的时间被同步到公共时钟源（例如 GPS）。这些技术也可用于异步系统，在异步系统，系统中多个基站的时间是不同步的。为清晰起见，假设每个扇区的主用户（将在下面进行定义）与该扇区的基站是同步的。

OFDMA 系统 100 利用 OFDM 调制技术，将整个系统带宽有效地分成多个（N）正交的子频带，其中  $N > 1$ ，并且通常是 2 的幂。这些子带也常被称为音频（tone）、子载波、段（bin）和频率子信道。采用 OFDM，每个子带与一个可用数据进行调制的相应子载波相关联。在一些 OFDM 系统中，只有  $N_D$  个子带用于数据传输， $N_P$  个子带用于导频传输， $N_G$  个子带未用，作为防护子带，以使系统满足频谱屏蔽（spectral mask）要求，其中， $N = N_D + N_P + N_G$ 。为简单起见，下面的描述假设所有 N 个子带都可用于数据传输。

图 2 示出了 OFDMA 系统中一个扇区的跳频。如上所述，使用跳频可获得各种益处，包括抵挡有害路径效应的频率分集和干扰随机化。在该例子中， $N = 8$ ，为这 8 个子带分配的编号是 1 至 8。最多可以定义 8 个业务信道，其中，每个信道在每个跳频周期内使用这 8 个子带中之一。可定义跳频周期等于一个或多个 OFDM 符号的持续时

间。

每个业务信道与一个不同的 FH 序列相关联。可以基于 FH 函数  $f_s(k,T)$ ，生成扇区中所有业务信道的 FH 序列，其中  $k$  表示业务信道编号或标识符 (ID)， $T$  表示系统时间，其单位是跳频周期。用 FH 函数  $f_s(k,T)$  中的  $N$  个不同  $k$  值，可以生成  $N$  个不同的 FH 序列。每个业务信道的 FH 序列表示在每个跳频周期内用于该业务信道的一个具体子带。

图 2 示出了用于两个业务信道 1 和 4 的子带。业务信道 1 的 FH 序列和子带用黑色方块表示，而业务信道 4 的 FH 序列和子带用斜线方格表示。从图 2 可以看出，每个业务信道以由其 FH 序列确定的伪随机方式，动态地在子带之间跳跃。在该例子中，业务信道 4 的 FH 序列  $f_s(4,T)$  是业务信道 1 的 FH 序列  $f_s(1,T)$  的垂直移动变体。业务信道 4 所用的子带与业务信道 1 所用的子带相关，如下：

$$f_s(4,T) = (f_s(1,T) + 3) \bmod N。$$

为了避免扇区内干扰，每个扇区可以使用其业务信道的正交 FH 序列。如果任何两个 FH 序列在任何跳频周期  $T$  内都不使用相同的子带，则 FH 序列相互正交。如图 2 所示，通过将每个扇区的 FH 序列定义成相互的垂直移动变体，可以获得这种正交状况。于是，各扇区的业务信道相互正交，因为它们与正交的 FH 序列相关。由于在每个跳频周期内每个子带只能被一个业务信道使用，所以，避免了相同扇区中的多个业务信道上发送的多个数据传输之间的干扰。

对于多扇区 OFDMA 系统，一个扇区中的用户的数据传输会干扰其他扇区中的用户的数据传输。为了使扇区间干扰随机化，对于不同扇区可以使用不同的伪随机 FH 函数。例如，可以将扇区  $s_1$  的 FH 函数  $f_{s_1}(k,T)$  定义成相对于扇区  $s_2$  的 FH 函数  $f_{s_2}(k,T)$  是伪随机的。在这种情况下，扇区  $s_1$  用于业务信道  $k$  的 FH 序列相对于扇区 2 用于业务信道  $m$  的 FH 序列将是伪随机的，其中， $k$  可以等于或不等于  $m$ 。当这些业务信道的 FH 序列之间发生“冲突”时，即，当  $f_{s_1}(k,T) = f_{s_2}(m,T)$  并且业务信道  $k$  和  $m$  在相同的跳频周期内使用相同的子带时，业务信道  $k$  和  $m$  之间产生干扰。但是，由于 FH 函数  $f_{s_1}(k,T)$  和  $f_{s_2}(m,T)$  的

伪随机本质，干扰将被随机化。

因此，可以将各扇区的 FH 序列定义成：

- 1、相互正交，以避免扇区内干扰；以及
- 2、相对于相邻扇区的 FH 序列是伪随机的，以避免扇区间干扰。

通过以上约束，由一个扇区分配了业务信道  $k$  的用户正交于由该扇区分配了其他业务信道的所有其他用户。但是，该用户与相邻扇区中使用不同 FH 函数的所有用户不正交。

再回到图 1 中，每个扇区同时支持一组无切换用户和一组软切换用户。每个用户可以用一个或多个扇区进行通信，这取决于该用户是否处于软切换状态。用户同时进行通信所用的扇区包括在“激活集”中。对于无切换用户，激活集包括单个扇区，即该用户的服务扇区。对于软切换用户，激活集包括多个扇区，这些扇区中的一个扇区（例如最强的接收扇区）被指定为该软切换用户的服务扇区。

每个扇区为该扇区的无切换用户分配具有正交 FH 序列的业务信道，因此，这些用户相互不干扰。每个软切换用户的服务扇区为该用户分配一个业务信道。每个软切换用户与其服务扇区内的其他用户正交，因此相互不干扰。但是，每个软切换用户与其激活集中的其他扇区中的其他用户不正交。因此，每个扇区的软切换用户可以或可以不干扰该扇区的无切换用户。这取决于该扇区或其他扇区是否为这些软切换用户分配了业务信道。

对于每个扇区，可以对该扇区的无切换用户进行功率控制，从而，如果存在来自该扇区的软切换用户的干扰以及来自其他扇区的用户的干扰，该扇区能够对它们的数据传输进行解码。也可以对软切换用户进行功率控制，从而它们激活集中的扇区能够对它们的数据传输进行解码，同时降低对无切换用户的干扰。

在一个实施例中，每个扇区处理它的接收信号，并恢复来自该扇区的无切换用户的数据传输。然后，每个扇区估计由无切换用户引起的干扰，并将其从接收信号中消除。每个扇区进一步处理它的消除了干扰的信号，以恢复来自该扇区的软切换用户的数据传输。

也可将每个扇区视为同时支持一组“主”用户和一组“次”用户。

对于每个扇区，主用户是由该扇区分配业务信道的用户，而次用户是由任何其他扇区分配业务信道的用户。每个扇区的主用户包括：(1) 该扇区的无切换用户；以及 (2) 服务扇区为该扇区的软切换用户。每个扇区的次用户包括服务扇区是该扇区之外的其他扇区的软切换用户。

在另一个实施例中，每个扇区处理它的接收信号，并恢复来自该扇区的主用户（包括该扇区的无切换用户以及由该扇区分配业务信道的软切换用户）的数据传输。然后，每个扇区估计由这些主用户引起的干扰，并从接收信号中消除该干扰。每个扇区进一步处理它的消除了干扰的信号，以恢复来自该扇区的次用户（由其他扇区分配业务信道）的数据传输。

每个扇区也可以通过除上述两个实施例之外的其他方式，恢复来自用户的数据传输，这同样落入本发明的保护范围之内。通常，消除尽可能多的干扰是理想的。但是，消除由特定用户引起的干扰的能力取决于对来自该用户的数据传输进行正确解码的能力，而这取决于其他因素，如对用户进行功率控制的方式。

图3示出了终端120x的一个实施例的框图，终端120x是OFDMA系统100中的一个终端。终端120x可用于无切换用户或软切换用户。为简单起见，图3只示出了终端120x的发射机部分。

在终端120x内，编码器/调制器314接收来自数据源312的业务数据以及来自控制器330的控制数据和其他数据。业务数据被指定在业务信道x上传输，该终端120x的服务扇区已将该信道分配给了终端120x。编码器/调制器314将接收数据进行格式化、编码、交织和调制，并提供调制符号（或简称之为“数据符号”）。每个调制符号是与该调制符号所用的调制模式相对应的信号群（signal constellation）中的一个具体点的复数值。

发射跳频（TX FH）开关316接收数据符号，并在业务信道x的合适子带上提供这些符号。业务信道x与FH序列x相关联，FH序列x表示在每个跳频周期T中用于业务信道x的具体子带。控制器330可以基于服务扇区的FH函数 $f_s(k, T)$ ，生成FH序列x。TX FH

开关 316 还可以在导频子带上提供导频符号，并进一步为不用于导频或数据传输的各子带提供零信号值。对于每个 OFDM 符号周期，TX FH 开关 316 提供  $N$  个子带的  $N$  个“发射”符号（包括数据符号、导频符号和零信号值）。

OFDM 调制器 318 接收各 OFDM 符号周期的  $N$  个传输符号，并提供相应的 OFDM 符号。OFDM 调制器 318 通常包括快速傅立叶反变换 (IFFT) 单元和循环前缀生成器。对于每个 OFDM 符号周期，IFFT 单元使用  $N$  点傅立叶反变换，将这  $N$  个发射符号变换到时域，以获得包含  $N$  个时域“码片”的“变换后”符号。每个码片都是在一个码片周期中传输的复数值。然后，循环前缀生成器重复每个变换后符号的一部分，以形成包含  $N + C_p$  个码片的 OFDM 符号，其中  $C_p$  是被重复的码片数量。重复部分通常被称为循环前缀，并用于抵抗由频率选择性衰落所导致的符号间干扰 (ISI)。OFDM 符号周期对应于一个 OFDM 符号的持续时间，是  $N + C_p$  个码片周期。OFDM 调制器 318 提供 OFDM 符号流。

发射机单元 (TMTR) 320 接收和处理 OFDM 符号流，以获得调制信号。发射机单元 320 可以基于从控制器 330 接收的功率控制信号，进一步调整 OFDM 符号和/或调制信号的幅度。从天线 322 将调制信号发送到终端 120x 的激活集中的基站。

图 4A 是同步 OFDMA 系统中的基站 110x 的一个实施例的框图。基站 110x 是扇区  $s_x$  的固定站。为简单起见，图 4 只示出了基站 110x 的接收机部分。

天线 412 接收由基站 110x 覆盖范围内的终端发送的调制信号。来自天线 412 的接收信号可以包括：(1) 来自扇区  $s_x$  的无切换用户的一个或多个调制信号；以及 (2) 来自扇区  $s_x$  的软切换用户的一个或多个调制信号。将接收信号提供给接收机单元 (RCVR) 414 并由接收机单元 (RCVR) 414 进行处理，以获得采样。然后，OFDM 解调器 416 处理采样，并提供“接收”符号，“接收”符号是由基站 110x 接收、由所有终端发送的组合发射符号的噪声估计。OFDM 解调器 416 通常包括循环前缀去除单元和 FFT 单元。对于每个 OFDM 符号

周期，循环前缀去除单元去除每个接收 OFDM 符号中的循环前缀，以获得接收变换符号。然后，FFT 单元用 N 点 FFT，将每个接收变换符号变换到频域，以获得这 N 个子带的 N 个接收符号。

RX 数据处理器 420 获取每个 OFDM 符号周期的 N 个接收符号，并处理这些符号，以获得每个终端向基站 110x 发射的解码数据。下面详细描述 RX 数据处理器 420 的处理。将每个终端的解码数据提供给数据接收装置 422，进行存储。

控制器 330 和 430 分别控制终端 120x 和基站 110x 处的操作。存储器单元 332 和 432 分别为控制器 330 和 430 使用的程序代码和数据提供存储。

图 4B 示出了异步 OFDMA 系统中的基站 110y 的一个实施例的框图。对于异步系统，次用户的时间和主用户的时间可以不同。OFDM 解调器/RX 数据处理器 440 基于用户的时间，对每个用户执行 OFDM 解调。OFDM 解调器/RX 数据处理器 440 还对时域符号执行干扰消除，如下所述。

在下面描述的实施例，扇区  $s_x$  的主用户是由扇区  $s_x$  分配业务信道的用户，而扇区  $s_x$  的次用户是由除扇区  $s_x$  之外的其他扇区分配业务信道的用户。扇区  $s_x$  的主用户可以是扇区  $s_x$  的无切换用户，或者是扇区  $s_x$  中服务扇区是扇区  $s_x$  的软切换用户。扇区  $s_x$  的次用户是扇区  $s_x$  中服务扇区是除扇区  $s_x$  之外的其他扇区的软切换用户。

图 5 示出了同步 OFDMA 系统中如图 4A 所示的基站 110x 内的 RX 数据处理器 420 的一个实施例的框图。在该实施例中，RX 数据处理器 420 包括 P 个主用户的 P 个数据处理器 510a 至 510p、干扰估计器 520、干扰消除器 530 和 S 个次用户的 S 个数据处理器 540a 至 540s，其中  $P \geq 1$  且  $S \geq 1$ 。

对于每个 OFDM 符号周期，OFDM 解调器 416 将这 N 个子带的 N 个接收符号提供给数据处理器 510a 至 510p 和干扰消除器 530。分配一个数据处理器 510，以恢复来自每个主用户的数据传输。下面描述数据处理器 510a 对来自主用户 1 的数据传输的处理。业务信道  $p_1$  被分配给主用户 1，业务信道  $p_1$  与 FH 序列  $p_1$  相关联。

在数据处理器 510a 中, RX FH 开关 514a 在每个 OFDM 符号周期内接收  $N$  个子带的  $N$  个接收符号。RX FH 开关 514a 将业务信道  $p_1$  的接收数据符号提供给解调器/解码器 516a, 并将主用户 1 的接收导频符号提供给信道估计器 518a。由于业务信道  $p_1$  在子带之间动态跳跃, 所以, RX FH 开关 514a 与主用户  $p_1$  的终端处的 TX FH 开关 316 一致地工作, 以从业务信道的合适子带中提取出接收数据符号。提供给 RX FH 开关 514a 的 FH 序列与提供给主用户 1 终端处的 TX FH 开关 316 的 FH 序列相同。此外, 这些 FH 序列是同步的。

信道估计器 518a 从 RX FH 开关 514a (如图 5 所示) 或从接收符号中获取主用户 1 的接收导频符号。然后, 信道估计器 518a 基于接收导频符号, 获取主用户 1 的信道估计。该信道估计可以包括以下估计: (1) 主用户 1 的终端和用于数据传输的各子带的基站 110x 之间的信道增益; (2) 从主用户 1 接收的导频的信号强度; 以及 (3) 其他测量值。

解调器/解码器 516a 可以用来自信道估计器 518a 的信道估计, 对来自 RX FH 开关 514a 的接收数据符号进行相干解调, 以获得主用户 1 的数据符号估计。解调器/解码器 516a 进一步对该数据符号估计进行解调 (即去除符号映射)、去除交织和解码, 以获得主用户 1 的解码业务数据。通常, 主用户 1 的基站 110x 内的单元所执行的处理与该主用户的终端内的相应单元所执行的处理互补。

数据处理器 510a 至 510p 分别提供主用户 1 至  $P$  的解码业务数据和信道估计。干扰估计器 520 接收主用户 1 至  $P$  的解码业务数据和信道估计, 估计由这  $P$  个主用户中每个用户引起的干扰, 并将这  $P$  个主用户的干扰估计提供给干扰消除器 530。干扰消除器 530 在每个 OFDM 符号周期内接收  $N$  个子带的  $N$  个接收符号以及这  $P$  个主用户的干扰估计。对于每个 OFDM 符号周期, 干扰消除器 530 确定这  $N$  个子带上的由这  $P$  个主用户引起的总干扰, 从每个子带的接收符号中减去该总干扰, 并提供这  $N$  个子带的  $N$  个消除了干扰的符号。下面描述干扰估计器 520 和干扰消除器 530。

分配一个数据处理器 540, 以恢复来自每个次用户的数据传输。

每个数据处理器 540 包括：RX FH 开关 544、解调器/解码器 546 和信道估计器 548，它们的工作方式分别类似于数据处理器 510 内的 RX FH 开关 514、解调器/解码器 516 和信道估计器 518。但是，向每个数据处理器 540 内的 RX FH 开关 544 提供  $N$  个消除了干扰的符号，而不是  $N$  个子带的  $N$  个接收符号。此外，每个数据处理器 540 内的 RX FH 开关 544 与由该数据处理器恢复的次用户终端处的 TX FH 开关协调一致地工作。数据处理器 540a 至 540s 分别提供次用户 1 至  $S$  的解密业务数据（以及信道估计）。

图 6 是同步 OFDMA 系统中如图 4A 所示的 RX 数据处理器 420 内的干扰估计器 520 和干扰消除器 530 的一个实施例的框图。在该实施例中，干扰估计器 520 包括对于  $P$  个主用户的  $P$  个每终端干扰估计器 620a 至 620p。分配一个每终端干扰估计器 620，以估计由每个主用户引起的干扰。下面描述每终端干扰估计器 620a 执行的处理，以估计由主用户 1 引起的干扰。

在每终端干扰估计器 620a 中，编码器/调制器 622a 接收主用户 1 的解码业务数据。然后，编码器/调制器 622a 对解码业务数据进行编码、交织和调制，并提供数据符号。TX FH 开关 624a 从编码器/调制器 622a 接收数据符号，并在分配给主用户 1 的业务信道  $p_1$  的合适子带上提供这些符号，所述合适子带由与该业务信道相关联的 FH 序列  $p_1$  表示。TX FH 开关 624a 也可在合适子带上提供导频符号。TX FH 开关 624a 在每个 OFDM 符号周期内提供  $N$  个子带的  $N$  个发射符号。通常，编码器/调制器 622a 和 TX FH 开关 624a 所执行的处理与在主用户 1 的终端处的编码器/调制器 314 和 TX FH 开关 316 所执行的处理相同。

信道模拟器 628a 模拟主用户 1 的终端和基站 110x 之间的通信链路的影响。信道模拟器 628a 接收来自 TX FH 开关 624a 的发射符号以及主用户 1 的信道估计。然后，信道模拟器 628a 利用信道估计处理发射符号，以获得由主用户 1 引起的干扰的估计。例如，信道模拟器 628a 可以将每个子带上的发射符号乘以该子带的信道增益估计，以获得该子带上由主用户 1 引起的干扰分量。

接收符号包含由扇区  $s_x$  的主用户和次用户发射的符号的信号分量。来自信道模拟器 628a 的干扰估计就是由主用户 1 发送的符号的信号分量。该干扰估计包括  $N$  个子带的  $N$  个干扰分量，其中，如果主用户 1 在某子带上没有发送数据或导频符号，则该特定子带的干扰分量是零。

每终端干扰估计器 620a 至 620p 分别处理主用户 1 至  $P$  的解码业务数据。每终端干扰估计器 620a 至 620p 内的信道模拟器 628a 至 628p 分别提供主用户 1 至  $P$  的干扰估计。

干扰消除器 530 包括  $N$  个  $P$  输入端加法器 630a 至 630n 以及  $N$  个两输入端加法器 632a 至 632n，即用于这  $N$  个子带中每一个子带的一组加法器 630 和 632。干扰消除器 530 从 OFDM 解调器 416 接收这  $N$  个子带的  $N$  个接收符号，并从干扰估计器 620a 至 620p 接收主用户 1 至  $P$  的干扰估计。在干扰消除器 530 内，加法器 630a 接收子带 1 上由  $P$  个主用户引起的干扰分量，并将其相加，然后提供子带 1 上的总干扰。子带 2 至  $N$  的其他  $N-1$  个加法器 630 中的每一个加法器接收关联子带上由这  $P$  个主用户引起的干扰分量，并将其相加，然后提供该子带上的总干扰。加法器 632a 接收子带 1 上的总干扰，并将其从子带 1 的接收符号中减去，然后提供子带 1 的消除了干扰的符号。子带 2 至  $N$  的其他  $N-1$  个加法器 632 中的每一个类似地接收关联子带上的总干扰，并将其从该子带的接收符号中减去，然后提供该子带的消除了干扰的符号。加法器 632a 至 632n 提供每个 OFDM 符号周期的  $N$  个子带的  $N$  个消除了干扰的符号。

图 7 的框图示出了异步 OFDMA 系统中如图 4B 所示的基站 110y 内的 OFDM 解调器/RX 数据处理器 440 的一个实施例。在该实施例中，OFDM 解调器/RX 数据处理器 440 包括  $P$  个主用户的数据处理器 710a 至 710p、干扰估计器 720、干扰消除器 730 和  $S$  个次用户的  $S$  个数据处理器 740a 至 740s，其中， $P \geq 1$  且  $S \geq 1$ 。

将来自接收机单元 414 的恢复符号提供给数据处理器 710a 至 710p 中的每一个。每个数据处理器 710 包括：OFDM 解调器 712、RX FH 开关 714、解调器/解码器 716 和信道估计器 718。每个数据处

理器 710 内的 OFDM 解调器 712 基于分配给该数据处理器的主用户的时间,对接收符号执行 OFDM 解调,并提供  $N$  个子带的符号估计。然后, RX FH 开关 714、解调器/解码器 716 和信道估计器 718 对符号估计执行操作,方式与图 5 所描述的 RX FH 开关 514、解调器/解码器 516 和信道估计器 518 类似。每个数据处理器 740 也包括 OFDM 解调器 742,其基于分配给该数据处理器的次用户的时间,对消除了干扰的符号执行 OFDM 解调。

图 8 示出了异步 OFDMA 系统中如图 4B 所示的 OFDM 解调器/RX 数据处理器 440 内的干扰估计器 720 和干扰消除器 730 的一个实施例的框图。在该实施例中,干扰估计器 720 包括  $P$  个主用户的  $P$  个每终端干扰估计器 820a 至 820p。分配一个每终端干扰估计器 820,来估计由每个主用户引起的干扰。每个每终端干扰估计器 820 包括:编码器/调制器 822、TX FH 开关 824、OFDM 调制器 826 和信道模拟器 828。编码器/调制器 822 和 TX FH 开关 824 的操作方式与图 6 中的编码器/调制器 622 和 TX FH 开关 624 相同。TX FH 开关 824 在每个 OFDM 符号周期内提供  $N$  个子带的  $N$  个发射符号。然后,OFDM 调制器 826 对每个 OFDM 符号周期的  $N$  个发射符号执行 OFDM 调制,并提供时域符号。

然后,信道模拟器 828 用所分配的主用户的信道估计,处理时域符号,以获得由该主用户引起的干扰的估计。由于不同的主用户与异步系统的不同时间相关联,所以,信道模拟器 828 还执行采样率转换,从而使来自信道模拟器的干扰估计与接收符号时间校准。

干扰消除器 730 包括一个  $P$  输入端加法器 830 和一个两输入端加法器 832。干扰消除器 730 分别接收来自接收机单元 414 的接收符号和来自每终端干扰估计器 820a 至 820p 的主用户 1 至  $P$  的干扰估计。在干扰消除器 730 内,加法器 830 消除由这  $P$  个主用户引起的干扰,并提供总干扰。加法器 832 从接收符号中减去总干扰,然后提供消除了干扰的符号, $S$  个次用户的数据处理器 740a 至 740s 对其进行处理。

图 5 和 6 所示的实施例建议:估计由所有  $P$  个主用户引起的干扰,并消除该干扰,然后恢复来自  $S$  个次用户的数据传输。扇区  $s_x$  的主用

户可以是由该用户的激活集中的多个扇区进行功率控制的软切换用户。如果来自该主用户的数据传输被功率控制使得能够由该激活集中的其他扇区恢复，则扇区  $s_x$  的基站 110x 无法对来自该主用户的数据传输进行解码。如果来自任何主用户的数据传输都无法被解码，那么，基站 110x 不会试图去估计和消除由该主用户引起的干扰。基站可以使用部分解码的数据来消除一些干扰。

上面对图 5 和 6 的描述还适用于这样一个实施例：扇区  $s_x$  的一个主用户是扇区  $s_x$  的无切换用户，扇区  $s_x$  的一个次用户是扇区  $s_x$  的软切换用户（不管软切换用户的服务扇区）。

对于图 5 和 6 所示的实施例，在估计和消除由主用户引起的干扰之后，先对主用户进行解码，然后再对次用户进行解码。当然，也可以在估计和消除由次用户引起的干扰之后，先对次用户进行解码，然后再对主用户进行解码。总之，基站 110x 可以按照任何次序对来自用户的数据传输进行解码。可以估计和消除由每个成功解码的用户所引起的干扰，从而改善剩余未被解码的用户的信号质量。但是，如果对无切换用户进行功率控制使得存在来自软切换用户的干扰时能够对它们成功进行解码，则可以简化系统实现。在这种情况下，先对无切换用户进行解码，然后再对软切换用户进行解码。

为简单起见，图 5 和 6 给出了一种并行设计，其中：(1) 为每个主用户提供了一个数据处理器 510 和一个每终端干扰估计器 620；以及 (2) 为每个次用户提供了一个数据处理器 540。也可以使用时分复用设计 (TDM)，其中，提供一个数据处理器 510，让所有主和次用户对其进行时间共享，再提供一个每终端干扰估计器 620，让所有主用户对其进行时间共享。

图 9 是用于在无线通信系统（如跳频 OFDMA 系统）中发射数据的过程 900 的流程图。处于使用多个扇区的多个基站进行软切换的状态的各终端可以执行过程 900。

首先，从第一基站获取业务信道的分配（步骤 912）。对于跳频 OFDMA 系统，所分配的业务信道与一个 FH 序列相关联，该 FH 序列表示在每个时间间隔（即每个跳频周期）内用于数据传输的一个具

体子带。将数据进行编码和调制，以获得数据符号（步骤 914）。对于跳频 OFDMA 系统，在该 FH 序列所指示的子带上提供所述数据符号（步骤 916）。对所述数据符号做进一步处理（如 OFDM 调制），以通过所分配的业务信道传输到第一基站和第二基站（步骤 918）。

第一基站所分配的业务信道相互正交，并且与第二基站所分配的业务信道不正交。对于跳频 OFDMA 系统，第一基站和第二基站所分配的业务信道各自与相应的 FH 序列相关联。第一基站所分配的业务信道的 FH 序列相互正交，并且与第二基站所分配的业务信道的 FH 序列不正交。

图 10 是用于在无线通信系统（如跳频 OFDMA 系统）中接收来自多个终端的数据传输的过程 1000 的流程图。过程 1000 可由每个扇区的基站执行。为清楚起见，下面描述扇区  $s_x$  的基站  $x$  所执行的处理。

首先，获取接收符号（步骤 1012）。接收符号包括：（1）来自至少一个主终端的至少一个“主”业务信道上的至少一个数据传输；以及（2）来自至少一个次终端的至少一个“次”业务信道上的至少一个数据传输。主业务信道是由基站  $x$  分配的业务信道，而次业务信道则是由其他基站（如基站  $x$  的相邻基站）分配的信道。主业务信道相互正交，并且与次业务信道不正交。主业务信道相对于次业务信道可以是伪随机的。主终端是由基站  $x$  分配主业务信道的终端，而次终端是由其他基站分配次业务信道的终端。每个次终端处于使用至少两个基站（包括基站  $x$ ）进行软切换的状态，并且可由除基站  $x$  之外的其他基站分配次业务信道。

对于 OFDMA 系统，从 OFDM 解调器获取  $N$  个子带的接收符号。对于 OFDMA 系统，每个业务信道也与相应的 FH 序列相关联。主业务信道的“主”FH 序列相互正交，并且与次业务信道的“次”FH 序列不正交。

处理接收符号，以获得每个主终端的解码数据（步骤 1014）。估计由主终端引起的干扰（步骤 1016），并将其从接收符号中消除，以获得消除了干扰的符号（步骤 1018）。然后，处理消除了干扰的符号，以获得每个次终端的解码数据（步骤 1020）。

对于每个主终端的处理包括：(1) 获取由分配给该主终端的主业务信道的主 FH 序列所指示的子带上的接收符号；(2) 得到对于该主终端的信道估计（例如，基于从该主终端接收的导频符号）；以及 (3) 将该主终端的接收符号进行解调和解码（例如，用该主终端的信道估计），以获得该主终端的解码数据。以相似的方式，执行对于每个次终端的处理，不过是针对消除了干扰的符号，而非接收符号。

可以通过如下方式估计由每个主终端引起的干扰：(1) 对该主终端的解码数据进行编码和调制；(2) 在由分配给该主终端的 FH 序列所指示的子带上提供该数据符号；以及 (3) 用信道估计处理该数据符号，以获得由该主终端引起的干扰。可将由每个主终端引起的干扰进行合并，以获得由所述主终端引起的总干扰。

这里描述的技术可用于跳频 OFDMA 系统和其他类型的无线通信系统。例如，这些技术可用于采用诸如离散多音频（DMT）之类的其他多载波调制技术的系统。这些技术也可用于未使用多载波调制的无线通信系统和未采用跳频的无线通信系统。

这里描述的技术可用于以其他方式定义业务信道的系统。对于跳频 OFDMA 系统，业务信道是由关联的 FH 序列进行定义的，该 FH 序列表示在每个跳频周期内使用的一个具体子带。对于时分复用（TDM）系统，可以在时隙内传输数据，并且可以为多个业务信道分配不同的时隙。可将每个扇区的业务信道定义成相互正交，从而使得任何两个业务信道都不会使用相同的时隙。不同扇区的业务信道可以是伪随机的，从而使得一个扇区的业务信道和另一扇区的业务信道可以使用相同的时隙（因此它们将冲突）。这里描述的技术也可用于该 TDM 系统。每个软切换用户由其服务扇区分配一个业务信道。每个扇区恢复来自该扇区的主用户的数据传输，消除由这些主用户引起的干扰，然后恢复来自该扇区的次用户的数据传输。

如上所述，这里描述的技术可用于支持反向链路上的软切换。这些技术还可用于支持更软切换，在更软切换中，一个终端使用相同小区的多个扇区进行通信。对于软切换和更软切换，可以在基站和终端处执行相同的处理。

这里描述的技术也可用于前向链路。例如，一个终端可以在前向链路上接收来自一个基站的特定用户数据传输和来自多个基站的开销传输（如广播传输）。该终端可以处理它的接收信号，以恢复来自所述基站的特定用户数据传输，估计和消除由特定用户数据传输引起的干扰，并处理消除了干扰的信号，以恢复来自多个基站的开销传输。

这里描述的技术可用各种方式实现。例如，这些技术可用硬件、软件以及软硬件结合的方式实现。对于硬件实现，基站内的处理单元（如数据处理器 510 和 540、干扰消除器 520、干扰消除器 530 等）可以实现为一个或多个专用集成电路（ASIC）、数字信号处理器（DSP）、数字信号处理器件（DSPD）、可编程逻辑器件（PLD）、现场可编程门阵列（FPGA）、处理器、控制器、微控制器、微处理器、被设计用来执行这里所描述功能的其他电子单元及其组合。终端内的处理单元（如编码器/调制器 314、TX FH 开关 316、OFDM 调制器 318 等）也可实现在一个或多个 ASIC、DSP 等中。

对于软件实现，这里描述的技术可用执行这里描述的功能的模块（如过程、函数等）实现。这些软件代码可以存储在存储器单元（如图 3 中的存储器单元 332 和图 4 中的存储器单元 432）中，并由处理器（如控制器 330 和 430）执行。存储器单元可以实现在处理器内或处理器外，如果实现在处理器外，存储器单元经由本领域公知的各种方式可通信地连接到处理器。

前面提供了对所公开实施例的描述，以使本领域技术人员能够制造和使用本发明。对于本领域技术人员来讲，在不脱离本发明精神和保护范围的前提下，对这些实施例的各种修改是显而易见的，并且，这里定义的普遍原理也适用于其他实施例。因此，本发明不限于这里给出的实施例，而是与这里公开的原理和新颖特征的最宽泛范围相一致。



图1



图2

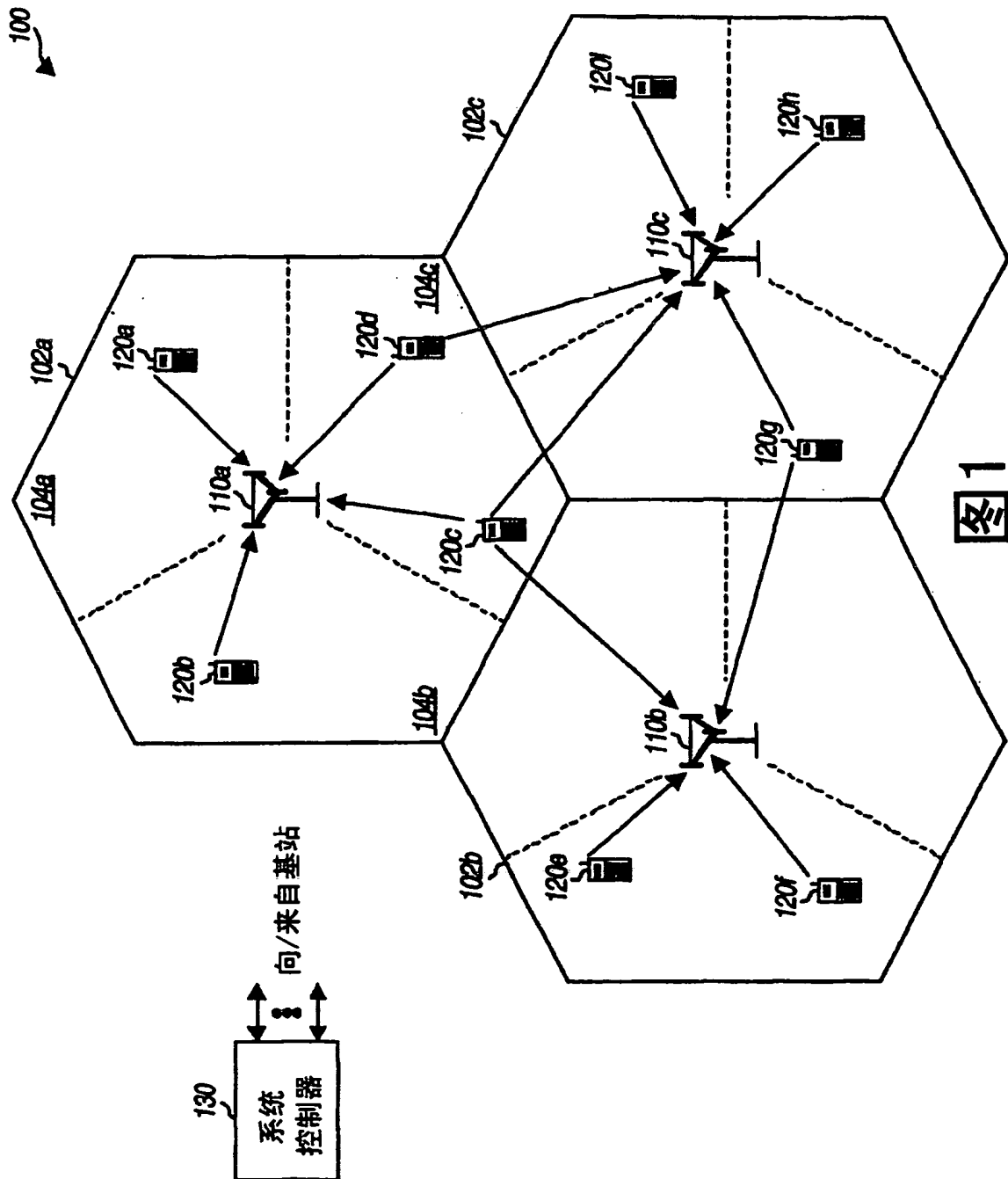

图3

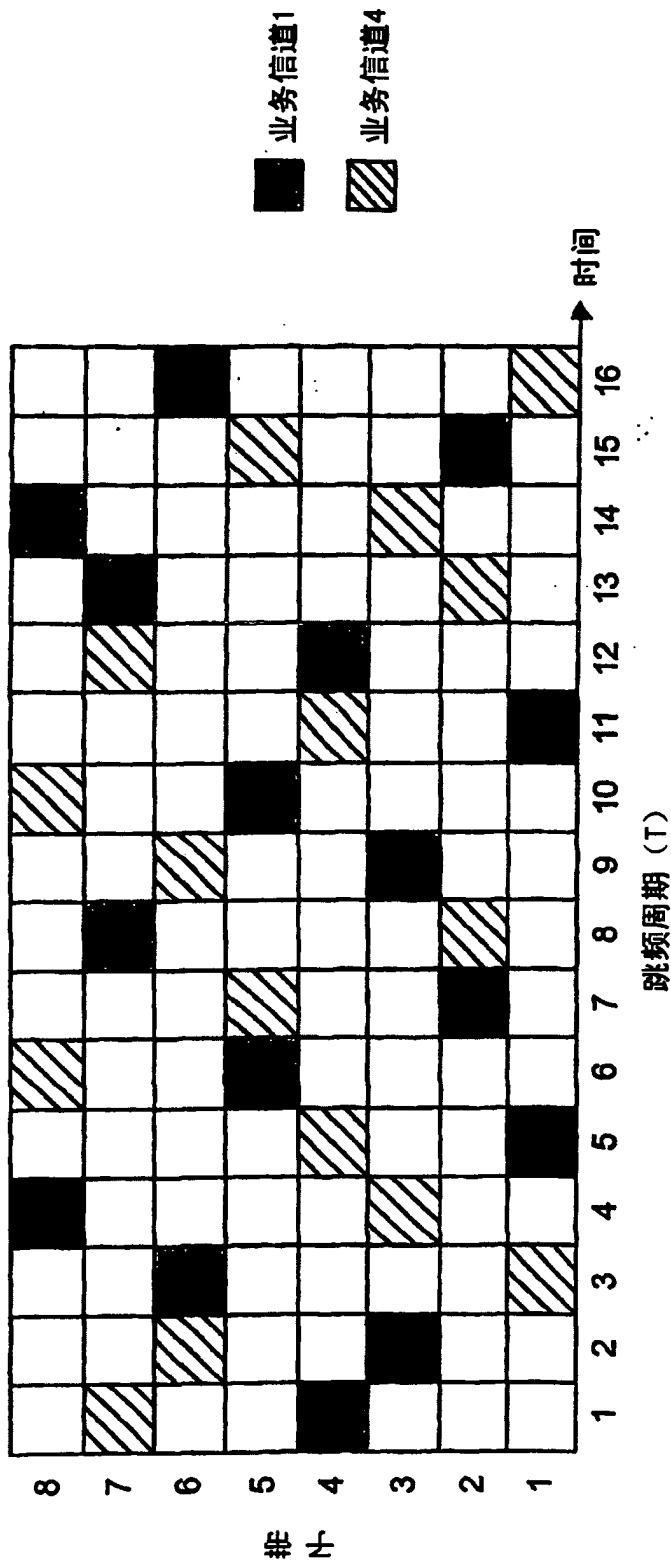

图4A

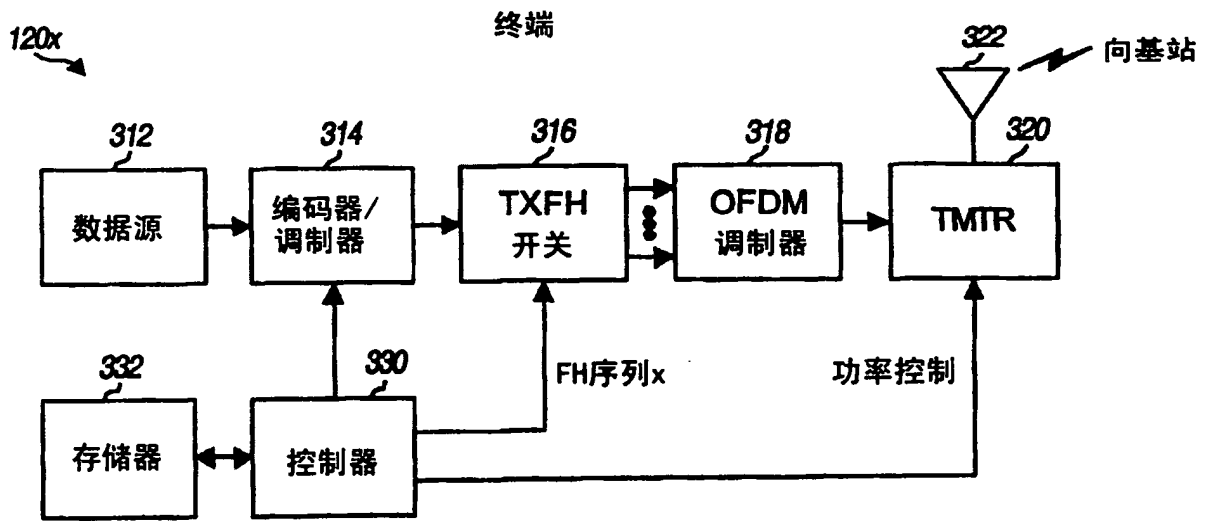

图4B

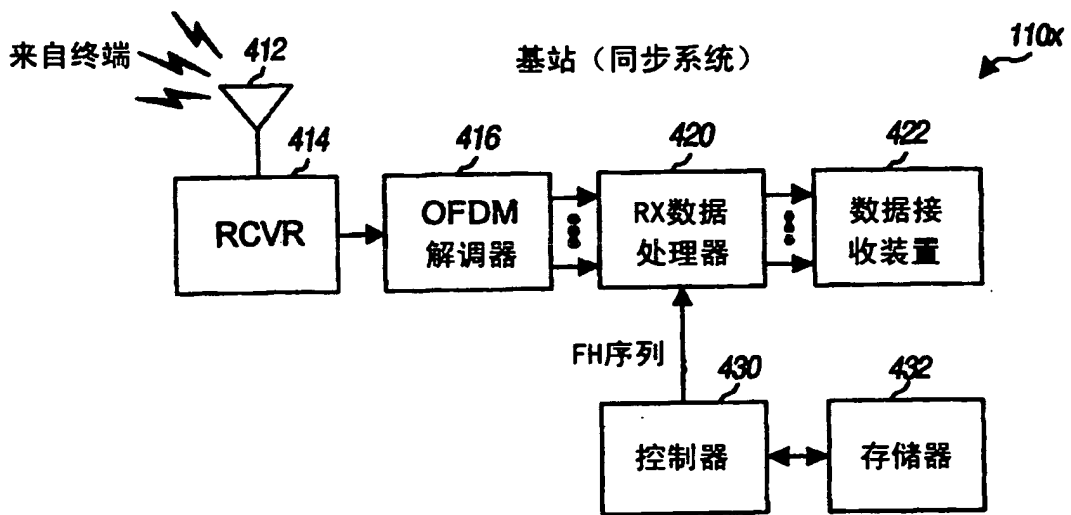

图5

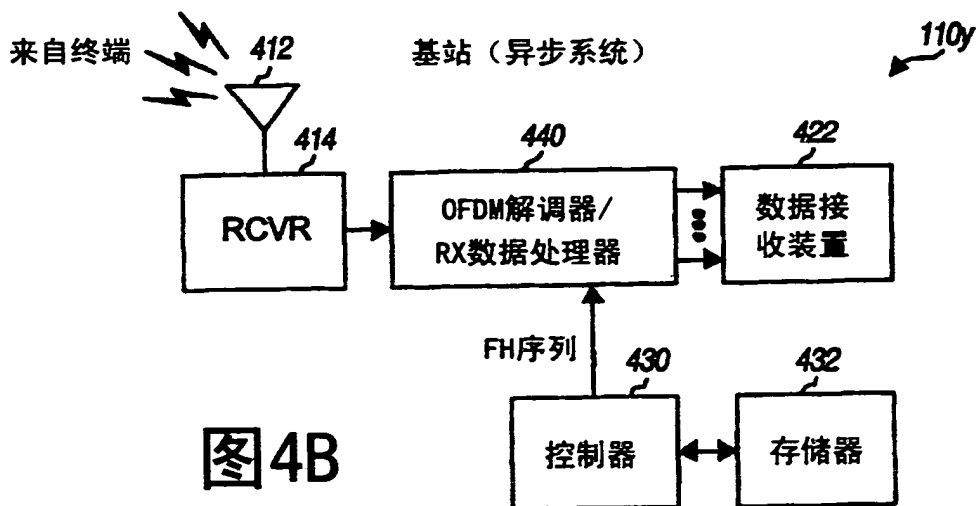

图6

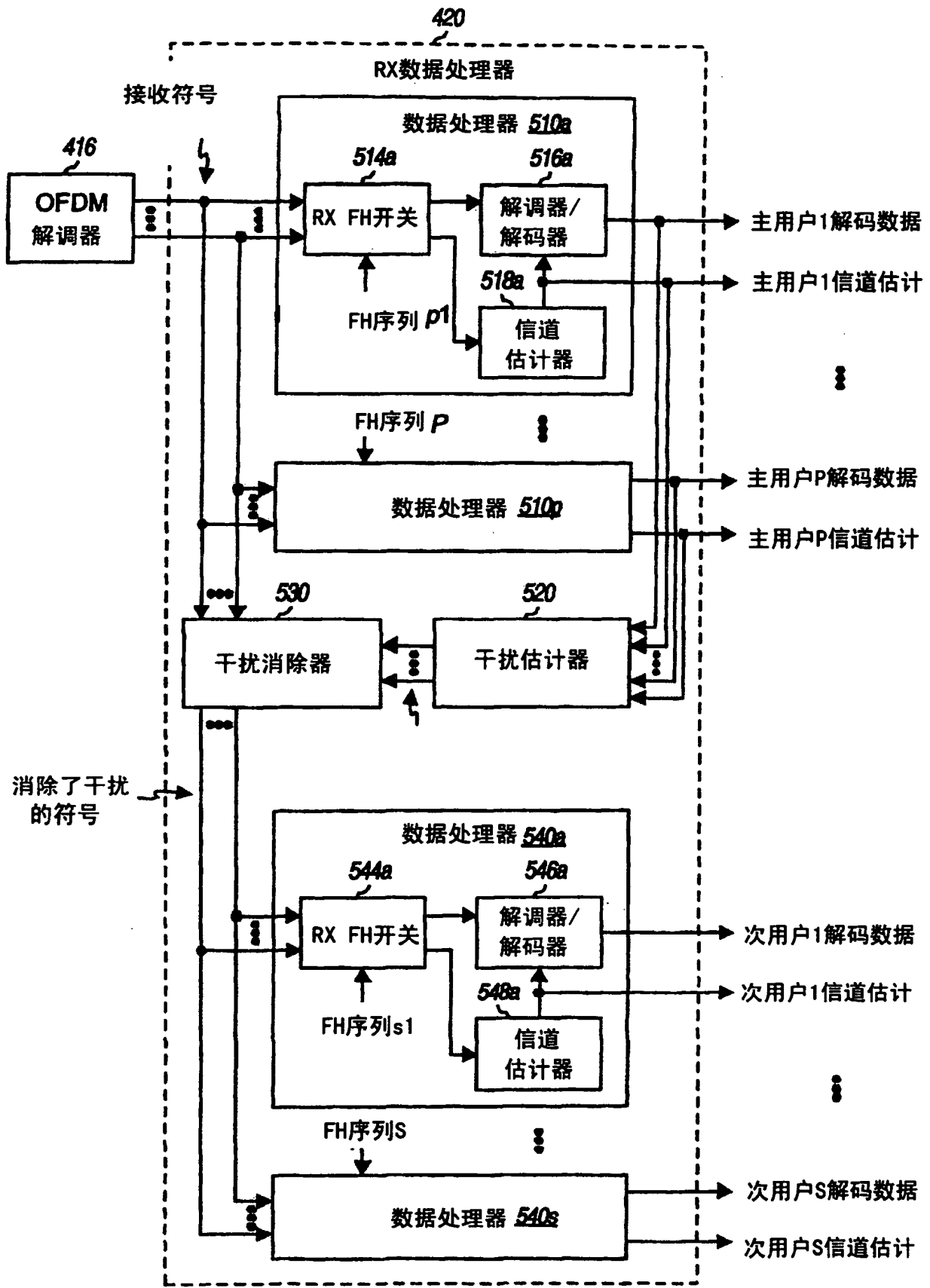

图7

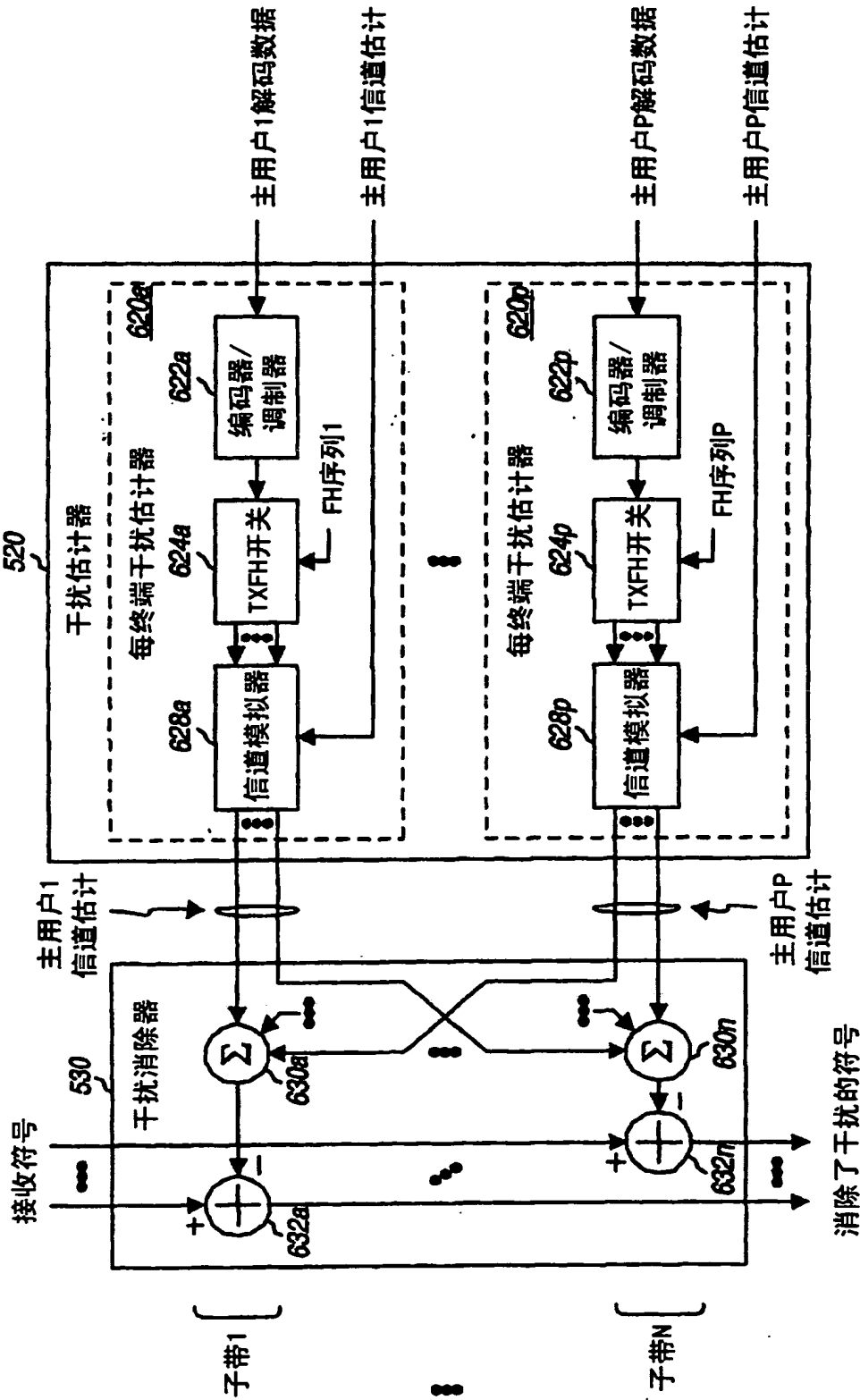

图8

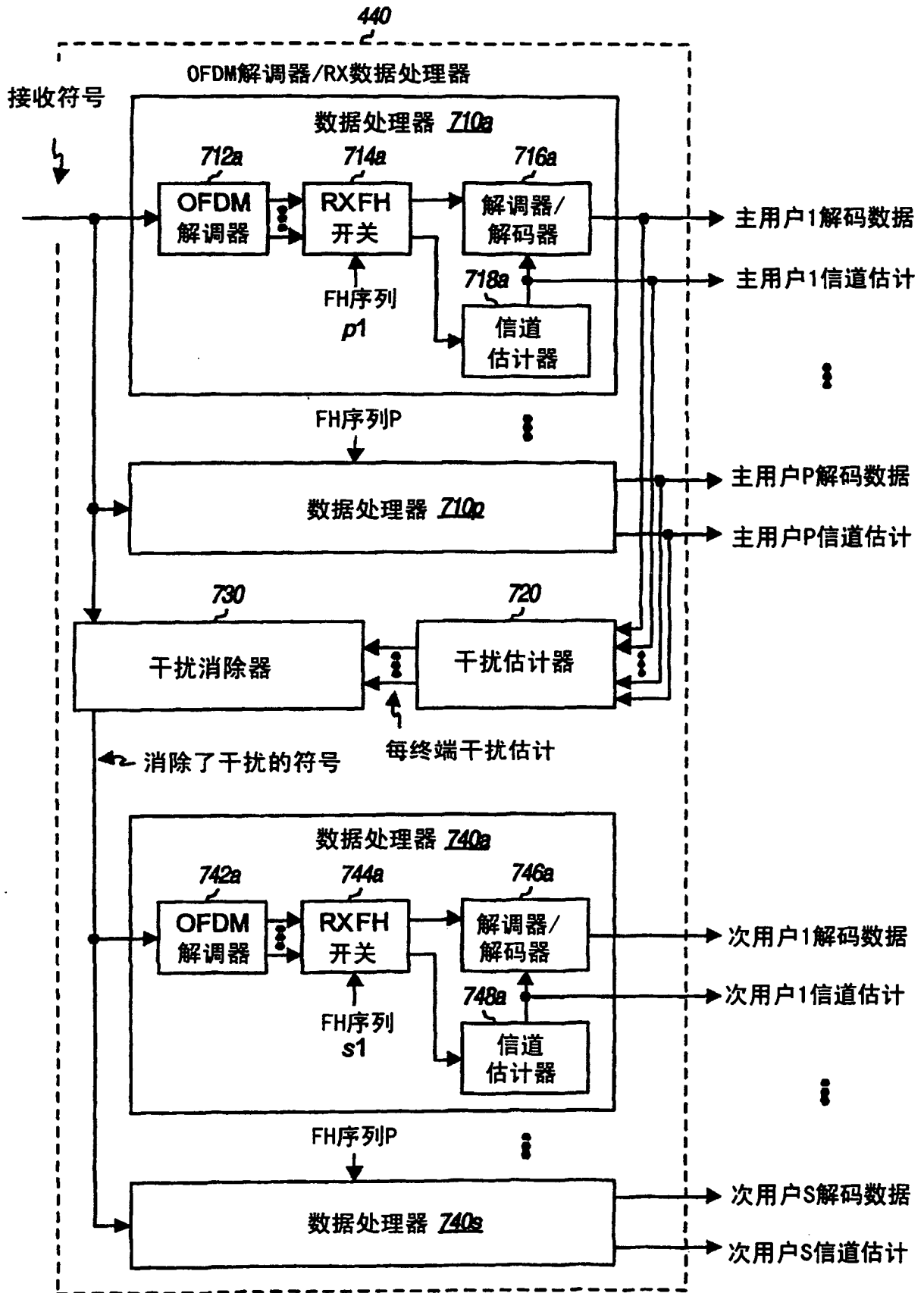

图9

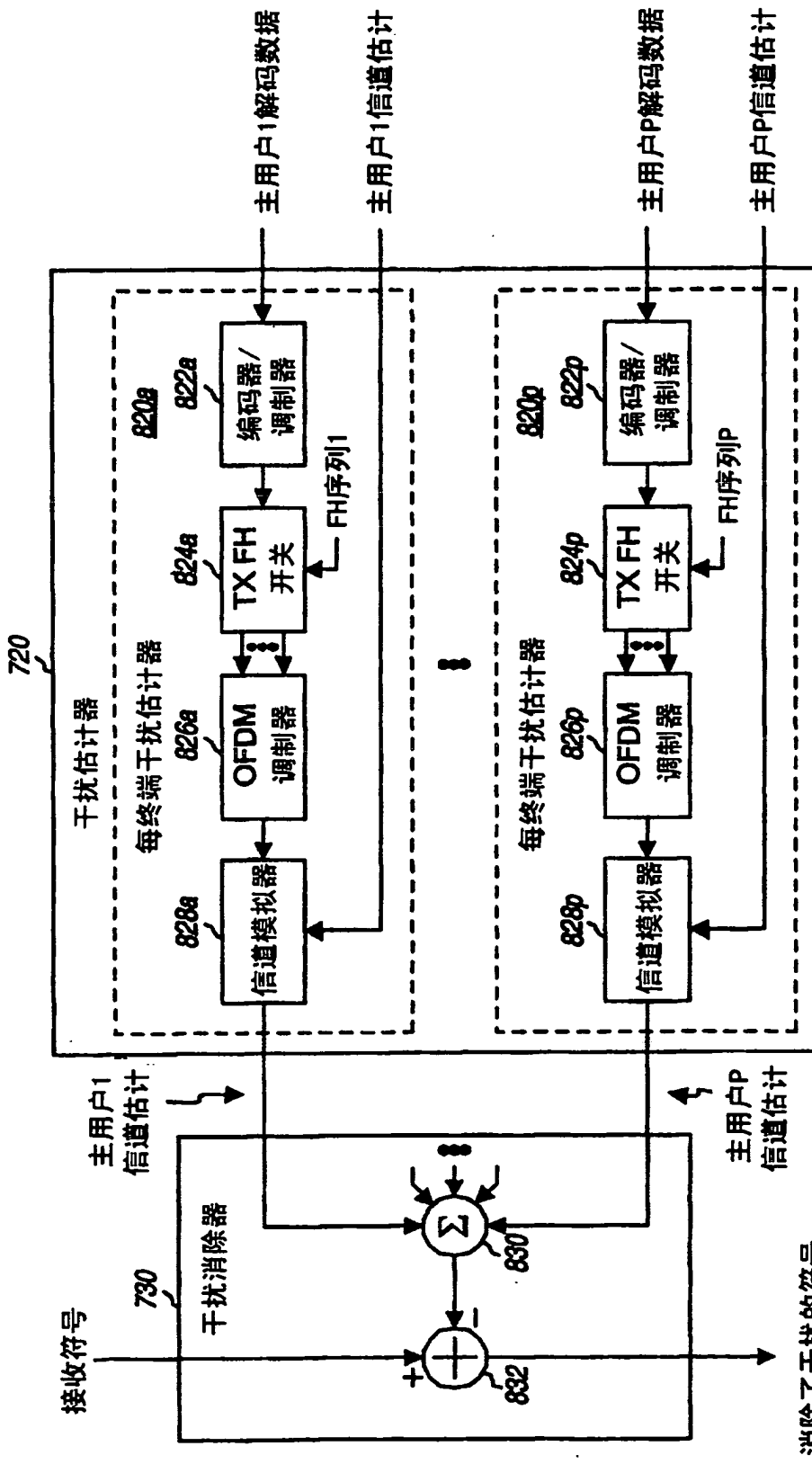
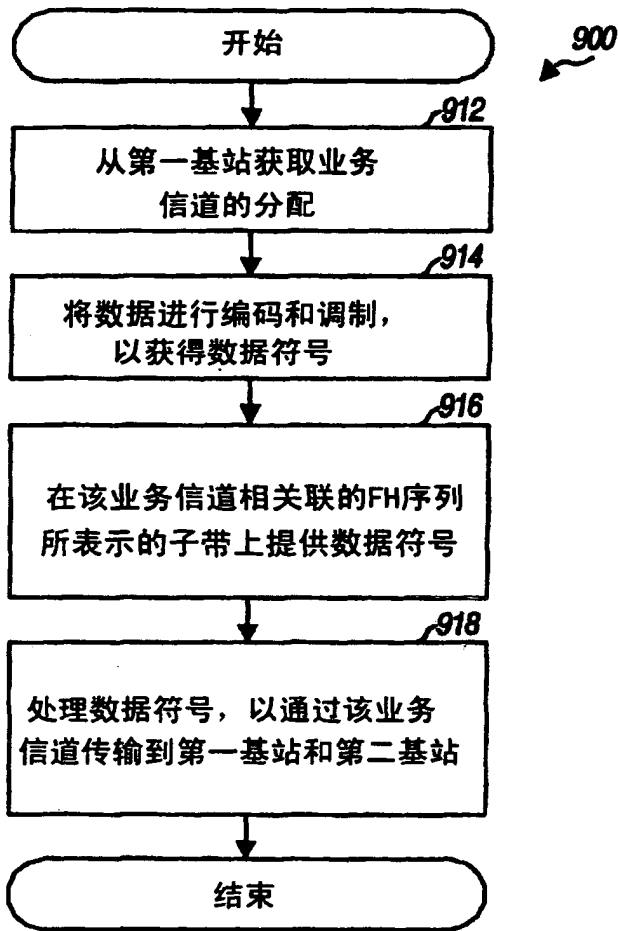
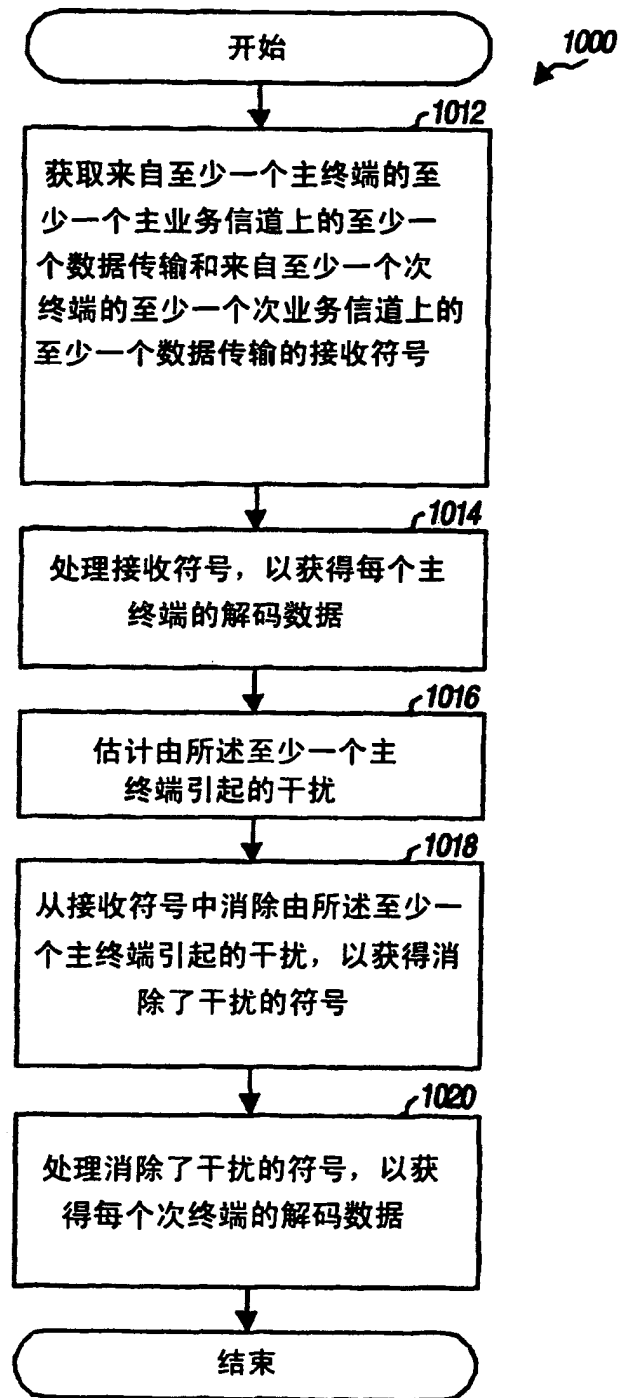

图10