

L. K. JOHNSON.
TYPE SETTING APPARATUS.

No. 523,741.

Patented July 31, 1894.

Fig. 1.

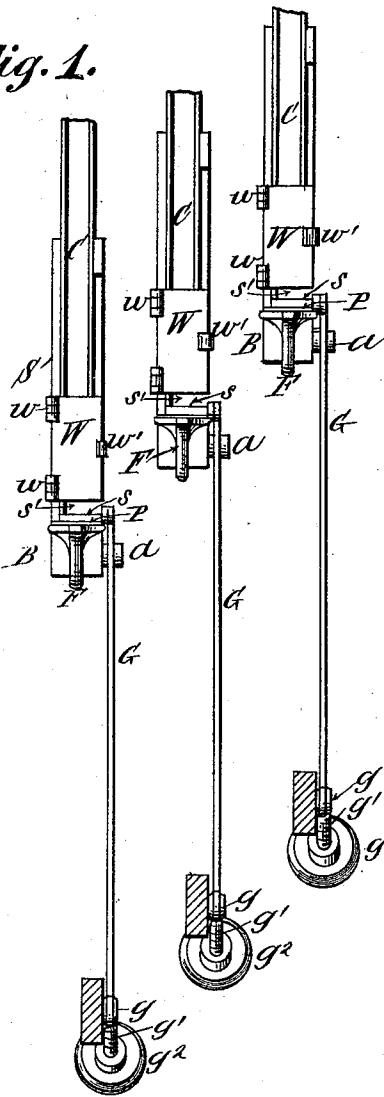

Fig. 2.

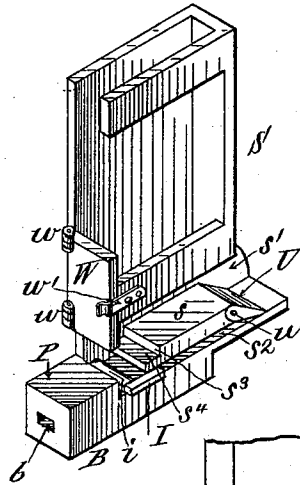
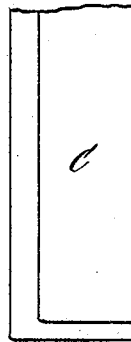

Fig. 3.



Witnesses:
D. W. Gardner.
Fowler Hirsch.

Inventor:
Louis K. Johnson
By his Attorney
George William Meath

L. K. JOHNSON.
TYPE SETTING APPARATUS.

No. 523,741.

Patented July 31, 1894.

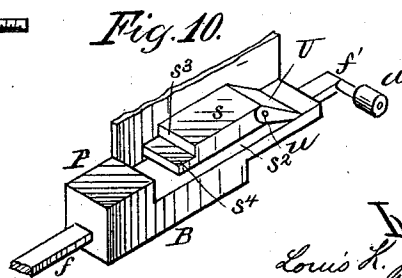
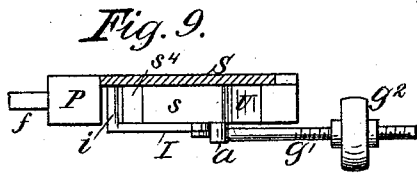
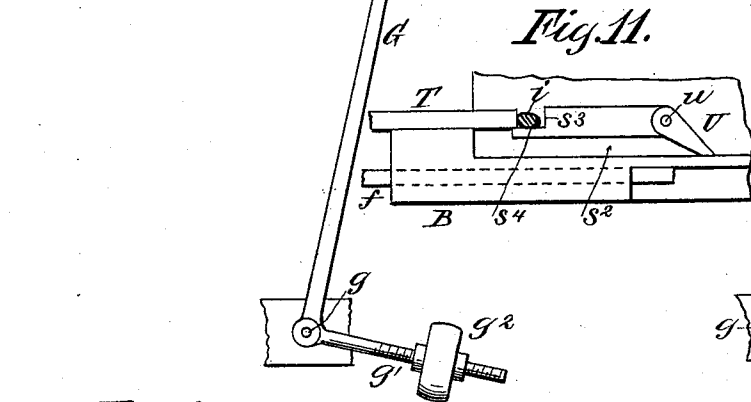
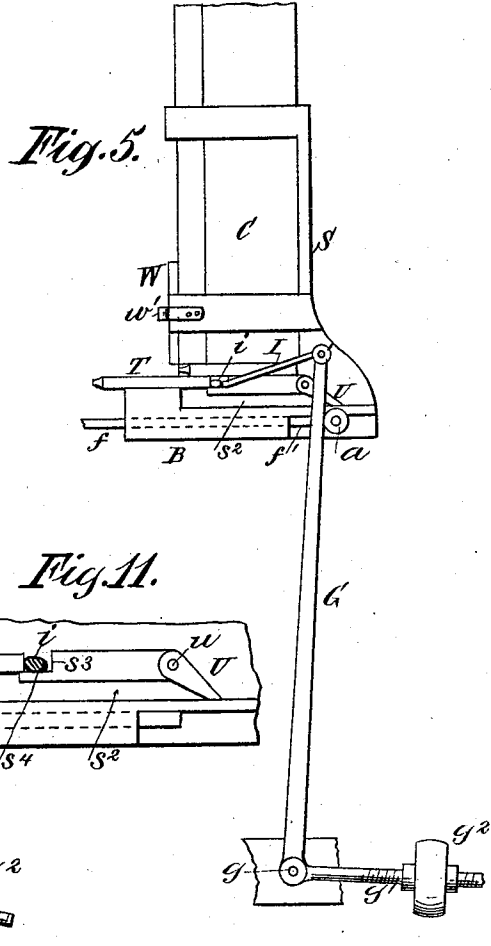
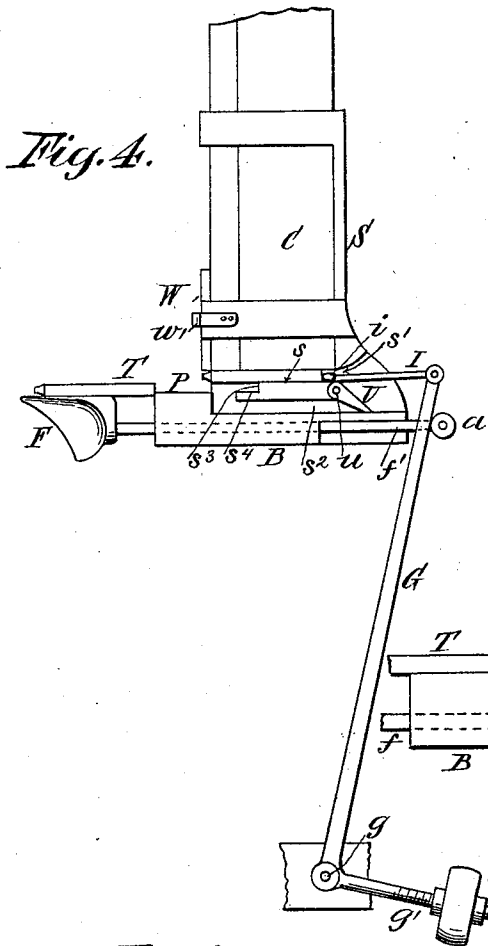

Witnesses:
D. W. Gardner.
J. Gross.

Inventor:
Louis K. Johnson
By his Attorney
George William Hiatt

L. K. JOHNSON.
TYPE SETTING APPARATUS.

No. 523,741.

Patented July 31, 1894.

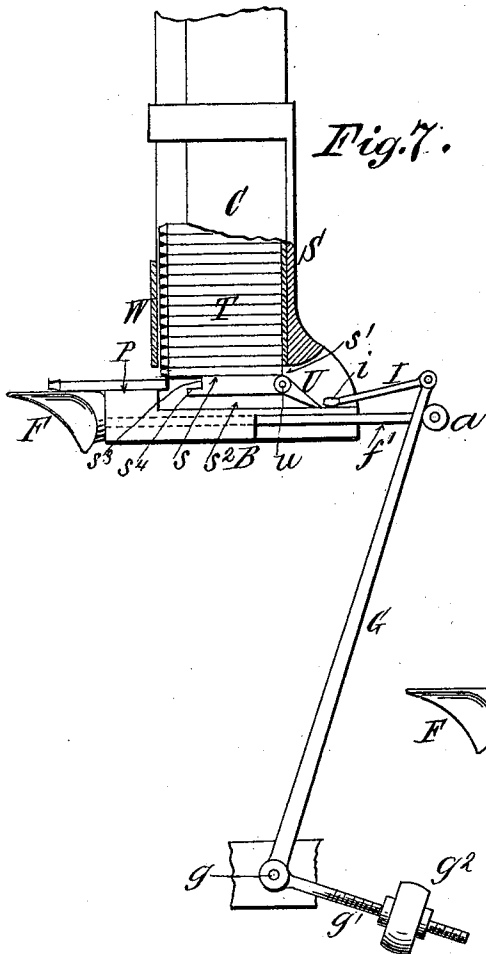

Fig. 7.

Fig. 6.

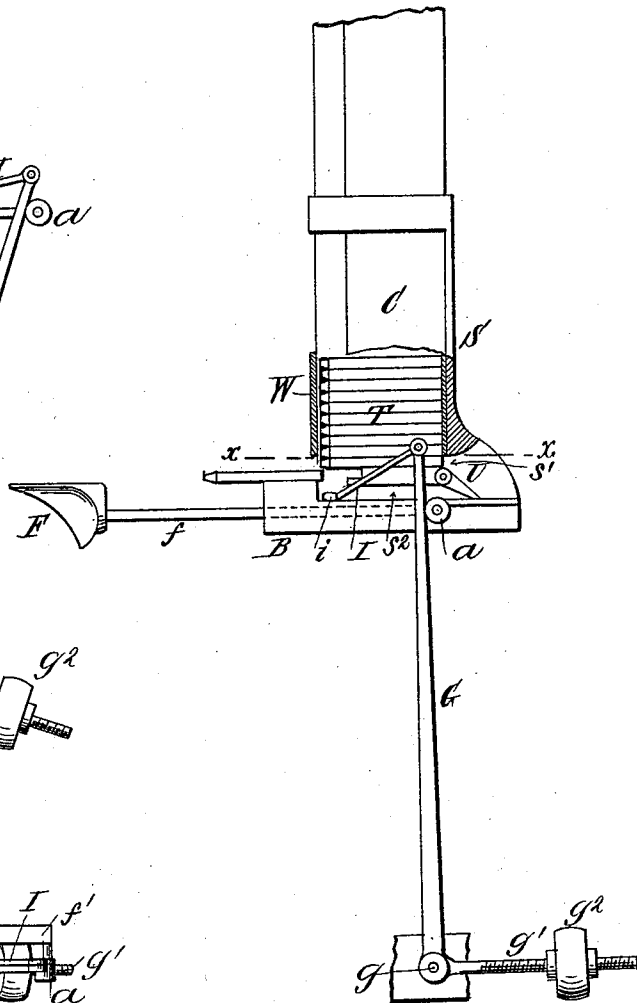
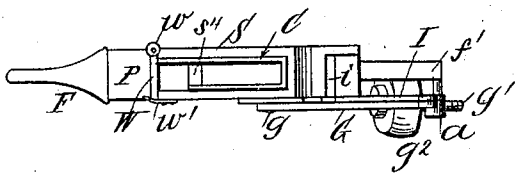

Fig. 8.



Witnesses:
D. W. Gardner,
Ferdor Hensch

Inventor:
Louis L. Johnson
By his attorney
George William Mith

UNITED STATES PATENT OFFICE.

LOUIS K. JOHNSON, OF BROOKLYN, ASSIGNOR TO THE ALDEN TYPE MACHINE COMPANY, OF NEW YORK, N. Y.

TYPE-SETTING APPARATUS.

SPECIFICATION forming part of Letters Patent No. 523,741, dated July 31, 1894.

Application filed December 1, 1893. Serial No. 492,429. (No model.)

To all whom it may concern:

Be it known that I, LOUIS K. JOHNSON, a citizen of the United States, residing in the city of Brooklyn, in the county of Kings and State of New York, have invented certain new and useful Improvements in Type-Setting Apparatus, of which the following is a specification, sufficient to enable others skilled in the art to which the invention appertains to make and use the same.

My improvements relate to the class of apparatus in which the types are arranged in upright columns in prescribed positions in type containing channels, the object of the invention being to facilitate the removal of the lower types by hand, as required.

In my last application, Serial No. 491,700, filed November 23, 1893, the type forwarder is retracted upon a lower plane than that of the type supporting shoulder as in the present case, but in said concurrent application the type forwarder is actuated individually by a push finger piece, and the next lowest type in a column bears against that being removed until the latter type is advanced beyond the face of the column. As a consequence the full weight of the column above increases the frictional resistance to the removal of the lowest type; and the face of the next succeeding snaps over the rear of the pusher finger and is worn and possibly injured thereby.

According to my present invention, the type forwarder is operated by a lever which is withdrawn during the act of removing a type previously detached from the column and resting free upon an extension of the type supporting shoulder; and the lowest type while being advanced by the type forwarder is relieved of the pressure of the column above by reason of a jog in the type supporting shoulder which allows the heel of the lowest type to clear the next succeeding type above before it has passed beyond the face of the column.

The invention also includes a hinged front guard for the types and means for holding it closed.

In the accompanying drawings I illustrate means for carrying out my improvements practically although I do not confine myself to the identical form and construction of parts

shown since it is obvious that various modifications may be introduced without departing from the spirit and intent of my invention. In practice the arrangement of parts shown is duplicated for each denomination of type to be contained in the setter case as a whole, and I herein illustrate only sufficient mechanism to give a clear idea of the novel parts and movements claimed.

Figure 1, is a front elevation representing three type containing channels supported in three separate socket pieces, and provided with independent type forwarding mechanism. Fig. 2, is an isometrical view of one of the channel sockets, type supporting shoulder, &c. Fig. 3, is a side elevation of the lower end of a type containing channel. Fig. 4, is a side elevation of the parts, showing the finger-piece slightly pulled forward, presumably by the thumb and finger of the compositor, the type shown upon the finger-piece being between the fingers of the operator, and the next succeeding type having been just started forward by the type forwarder. Fig. 5, is a similar view with the outer end of the finger-piece omitted; showing the advancing type and the pushing finger after they have dropped from contact with the type above, the advanced type resting upon the front platform. Fig. 6, is a similar view showing the completion of the forward stroke of the pusher; Fig. 7, a similar view showing the parts returned to their normal position. Fig. 8, is a top view of a single channel together with the supporting and operative parts. Fig. 9, is a horizontal section upon plane of line x, x , Fig. 6. Fig. 10, is an isometrical view of the type supporting shoulder depressed step, type finger channel underneath with its shunt and front type platform; Fig. 11, a side view upon an enlarged scale of the type supporting shoulder, &c., illustrating the function of the drop or step in the type supporting shoulder,—the type forwarding finger being shown in section.

The types T, are arranged in type containing channels C, which latter are supported in any suitable manner in a frame or rack, from which they may be removed individually. Any number of type channel supports may be combined in one case, preferably arranged

at slightly different elevations so as to permit of the channels being brought into close proximity vertically, while affording ample clearness for the fingers of the operator. As shown in the drawings, the lower ends of the channels C, are supported in the sockets S, which are in turn supported by the frame or rack or form a part thereof. The lower end of the type containing channel is shown in Fig. 3, one side wall being shorter than the other, so that when the other side wall rests upon the type supporting shoulder *s*, a transverse opening or slot *s'*, will be left above the type supporting shoulder and said shorter side wall of the channel. Below the type supporting shoulder *s*, is another slot or channel *s²*, at the rear end of which is the shunt U. Below the channel *s²*, is the sleeve or bearing B, formed with the rectangular recess *b*, in which the shank *f*, of the finger-piece F, rests and slides. To the rear end *f'*, of the pusher shank or rod *f*, is attached an anti-friction roller *a*. In front of this anti-friction roller *a*, and resting against it, is a lever G, pivoted to a stationary part of the apparatus at *g*, and formed with an arm *g'*, upon which a weight *g²*, is mounted adjustably, said weight tending constantly to hold the upper end of the lever G, against the anti-friction roller *a*, and thereby to hold the finger-piece F, back in its normal position against the front of the type platform P, as shown in Figs. 7 and 8. To the upper extremity of the lever G, is pivotally connected the type forwarder I, the forward end of which is formed with a laterally projecting type finger *i*.

The shunt U, may consist of any suitable means for automatically closing the rear end of the passage *s²*, after the passage underneath it of the type finger *i*. The latter as will be seen by reference to Figs. 2 and 9, projects laterally from one side of the type forwarder I, this finger *i*, alone entering and traveling through the passages *s'*, and *s²*. As shown in the drawings the automatic shunt U, consists of an inclined gate or pawl, the upper end of which is pivotally connected at *u*, to the rear end of the type shoulder *s*, from which it extends backward at an incline as will be seen by reference to Figs. 2, 4, 5, and 7, of the drawings.

The type supporting shoulder *s*, does not support the type above for its full length, the front portion of the type projecting beyond. The front edge *s³*, is formed with a step or depression *s⁴*, the upper surface of which is below that of the type shoulder a distance at least equal to the thickness of type used in the channel. As a consequence when the type has been forwarded sufficiently its heel drops upon the step *s⁴*, and is relieved of the weight of the column of type above. The type finger *i*, also drops down upon the step *s⁴*, and is supported by it until it has completed the advance of the type onto the top of the type platform P, and falls over the

edge *s³*, of the type support into the return channel *s²*.

The forward movement of the pusher finger *i*, is so rapid that in practice the contact between the heel of the type and the type finger *i*, is maintained until the type finger drops into the return channel *s²*. That is to say, the heel of the type during its descent to the step *s⁴*, is advanced at least the width of the pusher finger, so that the pusher finger, which, after the heel of the type advances beyond the edge *s³*, alone bears the weight of the column of types above, is snapped down upon the step *s⁴*,—a result that does not happen to the heel of the type because it is free from pressure excepting that exerted in the rear by the pusher finger.

The top of the type platform P, is upon the same plane as that of the step *s⁴*; and the types when in position thereon project beyond the platform P, and over the finger-piece F, so that the forward end of the type can be grasped between the thumb and finger of the operator, as he pulls out the finger piece F.

By providing for the dropping of the type to a lower level before the heel has passed beyond the face of the type above, I not only obviate the frictional contact and resistance afforded by the weight of the columns of types above, but I also prevent injury to the face of the next preceding type by reason of its scraping against the heel of the type being forwarded when the latter is clearing the line of the types above.

The front wall W, of the socket piece S, is made to act as a front guard to retain all the lowest types, excepting the one resting upon the type shoulder *s*, within the type containing channel.

The operative parts tend constantly to maintain their normal positions automatically by reason of the counterweight *g²*, adjustable upon the arm *g'*, of the lever G. The adjustment of the weight *g²*, provides for the accurate regulation and balancing of the parts with relation to the work to be done. It is obvious that a spring or other equivalent mechanism may be substituted for the weight *g²*.

The operation of my improved mechanism is as follows: The parts being in the position shown in Fig. 7, the operator, using his thumb and finger grasps the finger-piece F, at the same time grasping the front end of the type previously forwarded into position upon the type platform P. He then pulls the finger-piece outward, causing the anti-friction roller *a*, through the medium of the rod *f*, to carry forward the upper end of the lever G, against the resistance of the weight *g²*. As the type finger *i*, advances it rides up the shunt U, and encounters the heel of the lowest type upon the type supporting shoulder *s*, as indicated in Fig. 4. The continued advance of the type finger pushes the type off the type supporting shoulder *s*, the heel of the type

falling upon the step s^4 , the type finger following, and continuing to advance the type until it falls off the front s^3 , of the step, as shown in Fig. 6. When the operator releases the finger piece F, the parts are returned to their normal positions by the weight g^2 , the type finger returning through the channel s^2 , and underneath the shunt U, which yields in this direction to allow it to pass. The parts are then again in the position shown in Fig. 7.

The shunt U, shown in the drawings is supposed to be of sufficient weight to act automatically by gravity, but a spring pull or equivalent device may be substituted if preferred.

As shown in the drawings and for convenience of illustration, the socket S, type shoulder s , bearing B, and type platform P, are made in one piece, or connected together, but this is not essential. The several parts named may be supported independently, or otherwise formed as may be found most convenient in assembling a series of channels with their independent type forwarding mechanism in one piece.

The front guard W, is preferably hinged at one side, at w , w , and held closed at the other by a spring catch or equivalent fastening device w' . By this construction the channels can be slid into position from the front of the case, thus obviating the difficulty of supporting the columns of types when the channels are lifted into the socket pieces vertically.

What I claim as my invention, and desire to secure by Letters Patent, is—

1. In type setting mechanism, the combination of a type containing channel, a type

supporting shoulder formed with a channel underneath its type-supporting surface, an automatic shunt for closing said channel, an automatically retracting reciprocating type forwarder, and a pull finger piece for effecting the advance of the type forwarder, substantially in the manner and for the purpose described.

2. In type-setting mechanism the combination of a type containing channel, a type supporting shoulder formed with a step or depression in front for relieving the type when forwarded from the weight of the column of types above substantially in the manner and for the purpose described.

3. In type setting mechanism, the combination of a type containing channel, a type supporting shoulder formed with a step or depression in front to relieve the type when forwarded from the weight of the column of types above, and a support for the type forwarder formed immediately in front of, upon the same level as said depressed step substantially in the manner and for the purpose described.

4. In type setting mechanism the combination of a type-containing channel, a type supporting shoulder formed with a step or depression in front to relieve the types when forwarded from the weight of the column of types above, and a hinged front guard and catch for securing the same substantially in the manner and for the purpose described.

LOUIS K. JOHNSON.

Witnesses:

D. W. GARDNER,
GEORGE WILLIAM MIATT.