



(86) Date de dépôt PCT/PCT Filing Date: 2010/05/10
 (87) Date publication PCT/PCT Publication Date: 2010/12/09
 (85) Entrée phase nationale/National Entry: 2011/12/22
 (86) N° demande PCT/PCT Application No.: US 2010/034160
 (87) N° publication PCT/PCT Publication No.: 2010/141183
 (30) Priorité/Priority: 2009/06/04 (US12/478,576)

(51) Cl.Int./Int.Cl. *A61B 17/17* (2006.01),
A61B 17/72 (2006.01)
 (71) Demandeur/Applicant:
OLECRANAIL LLC, US
 (72) Inventeurs/Inventors:
EDWARDS, SCOTT G., US;
YAPP, RONALD ARTHUR, US
 (74) Agent: RIDOUT & MAYBEE LLP

(54) Titre : ENSEMBLE DE DISPOSITIF INTRAMEDULLAIRE ET PROCEDE ASSOCIE
 (54) Title: INTRAMEDULLARY DEVICE ASSEMBLY AND ASSOCIATED METHOD

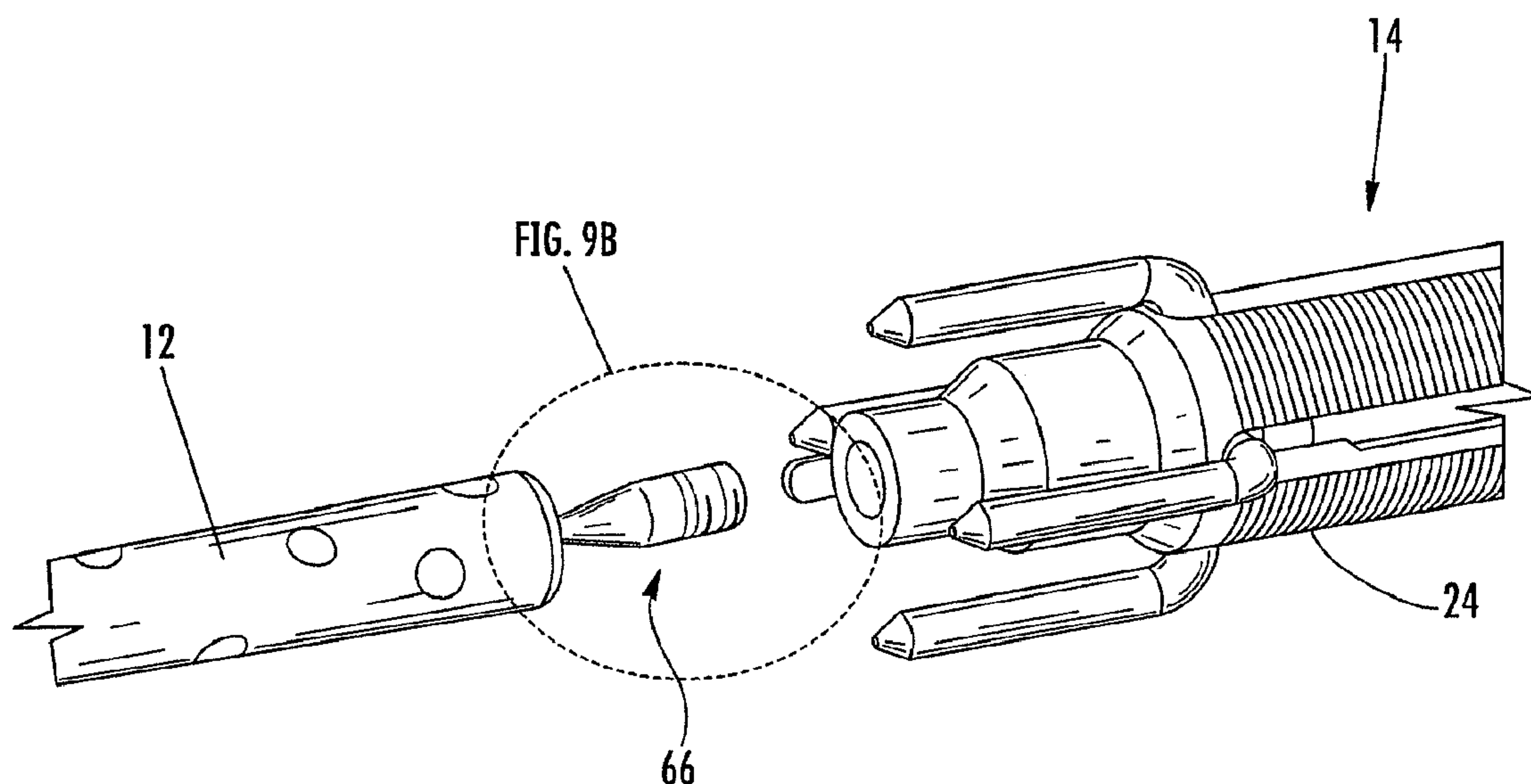

FIG. 9A

(57) **Abrégé/Abstract:**

An intramedullary device for repairing defects of a bone is provided. The intramedullary device is configured to be inserted into the medullary canal of a bone and includes a stud protruding from the end. The stud includes a portion that is tapered from a first cross-sectional area to a second cross-sectional where the second cross-sectional area is smaller than that of the first cross-sectional area and the second cross-sectional area defines a region of concentrated stress. The stud also includes a portion configured to engage the internal threads of a fastener retained within an intramedullary device assembly, such as a guide member adapter. The external threads of the stud engage the internal threads of the fastener to secure the intramedullary device to the intramedullary assembly when a first torque is applied to the fastener. Upon completion of insertion, compression, and securing of the intramedullary device in the medullary canal of a bone, the intramedullary device can be separated from the intramedullary device assembly by applying a second, greater torque to the internally-threaded fastener, whereby the stud breaks at the region of concentrated stress.

(12) INTERNATIONAL APPLICATION PUBLISHED UNDER THE PATENT COOPERATION TREATY (PCT)

(19) World Intellectual Property Organization
International Bureau(43) International Publication Date
9 December 2010 (09.12.2010)(10) International Publication Number
WO 2010/141183 A1

(51) International Patent Classification:

A61B 17/17 (2006.01) *A61B 17/72* (2006.01)

(21) International Application Number:

PCT/US2010/034160

(22) International Filing Date:

10 May 2010 (10.05.2010)

(25) Filing Language:

English

(26) Publication Language:

English

(30) Priority Data:

12/478,576 4 June 2009 (04.06.2009) US

(71) Applicant (for all designated States except US): **OLE-CRANAIL LLC** [US/US]; 8803 Windy Creek Way, Mclean, VA 22102 (US).

(72) Inventors; and

(75) Inventors/Applicants (for US only): **EDWARDS, Scott G.** [US/US]; 8803 Windy Creek Way, Mclean, VA 22102 (US). **YAPP, Ronald, Arthur** [US/US]; 7300 Hashley Road, Manchester, MI 48158 (US).(74) Agents: **THOMAS, Jonathan A.** et al.; Alston & Bird LLP, Bank Of America Plaza, 101 South Tryon Street, Suite 4000, Charlotte, NC 28280-4000 (US).

(81) Designated States (unless otherwise indicated, for every kind of national protection available): AE, AG, AL, AM, AO, AT, AU, AZ, BA, BB, BG, BH, BR, BW, BY, BZ, CA, CH, CL, CN, CO, CR, CU, CZ, DE, DK, DM, DO, DZ, EC, EE, EG, ES, FI, GB, GD, GE, GH, GM, GT, HN, HR, HU, ID, IL, IN, IS, JP, KE, KG, KM, KN, KP, KR, KZ, LA, LC, LK, LR, LS, LT, LU, LY, MA, MD, ME, MG, MK, MN, MW, MX, MY, MZ, NA, NG, NI, NO, NZ, OM, PE, PG, PH, PL, PT, RO, RS, RU, SC, SD, SE, SG, SK, SL, SM, ST, SV, SY, TH, TJ, TM, TN, TR, TT, TZ, UA, UG, US, UZ, VC, VN, ZA, ZM, ZW.

(84) Designated States (unless otherwise indicated, for every kind of regional protection available): ARIPO (BW, GH, GM, KE, LR, LS, MW, MZ, NA, SD, SL, SZ, TZ, UG, ZM, ZW), Eurasian (AM, AZ, BY, KG, KZ, MD, RU, TJ, TM), European (AL, AT, BE, BG, CH, CY, CZ, DE, DK, EE, ES, FI, FR, GB, GR, HR, HU, IE, IS, IT, LT, LU, LV, MC, MK, MT, NL, NO, PL, PT, RO, SE, SI, SK, SM, TR), OAPI (BF, BJ, CF, CG, CI, CM, GA, GN, GQ, GW, ML, MR, NE, SN, TD, TG).

Published:

— with international search report (Art. 21(3))

(54) Title: INTRAMEDULLARY DEVICE ASSEMBLY AND ASSOCIATED METHOD

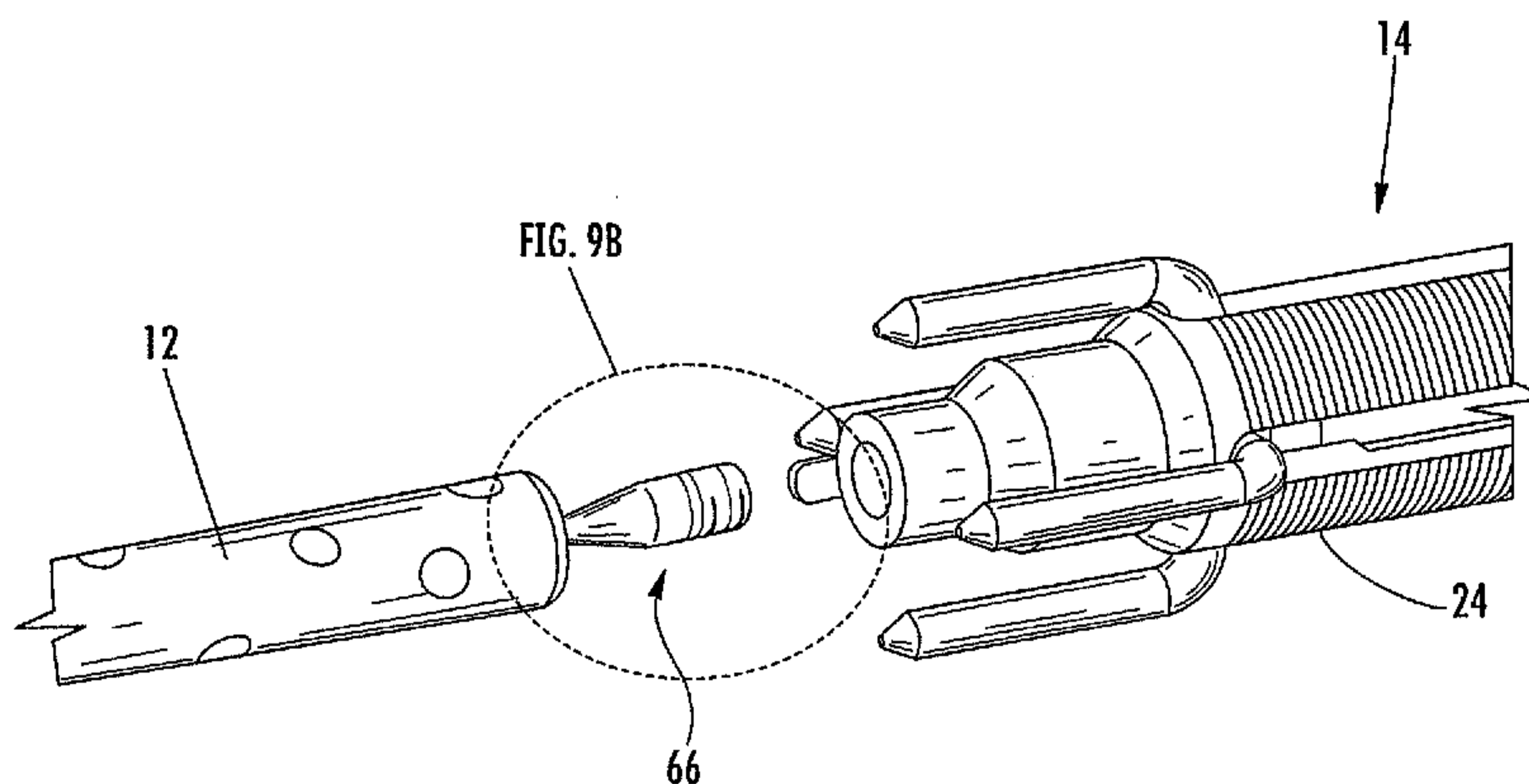

FIG. 9A

(57) **Abstract:** An intramedullary device for repairing defects of a bone is provided. The intramedullary device is configured to be inserted into the medullary canal of a bone and includes a stud protruding from the end. The stud includes a portion that is tapered from a first cross-sectional area to a second cross-sectional area where the second cross-sectional area is smaller than that of the first cross-sectional area and the second cross-sectional area defines a region of concentrated stress. The stud also includes a portion configured to engage the internal threads of a fastener retained within an intramedullary device assembly, such as a guide member adapter. The external threads of the stud engage the internal threads of the fastener to secure the intramedullary device to the intramedullary assembly when a first torque is applied to the fastener. Upon completion of insertion, compression, and securing of the intramedullary device in the medullary canal of a bone, the intramedullary device can be separated from the intramedullary device assembly by applying a second, greater torque to the internally-threaded fastener, whereby the stud breaks at the region of concentrated stress.

INTRAMEDULLARY DEVICE ASSEMBLY AND ASSOCIATED METHOD

FIELD OF THE INVENTION

Intramedullary devices for repairing bone defects and, more specifically, to intramedullary device assemblies for providing fixation, compression, and/or stabilization of the diaphysis or metaphysis of a long bone or periarticular bone.

5

BACKGROUND OF THE INVENTION

Intramedullary devices, such as nails, rods, or pins, are often used in the medical field to treat fractures of long bones, such as in the ulna and femur. These intramedullary devices also may be used to treat periarticular fractures, such as in the distal radius and proximal humerus. Such devices are typically designed to be inserted into the medullary canal of the fractured bone and generally are fastened to the bone segments on either side of the fracture to stabilize the bone and promote proper healing.

10

In some cases, the bone segments on either side of a fracture are spaced apart and must be brought closer together at the fracture to promote healing. Devices have been proposed that provide compression to such bone fractures by fixing the intramedullary device to one bone segment and then moving the free bone segment towards the fixed bone segment by way of compression applied to the end of the free bone segment. The free bone segment is then secured to the intramedullary device and the fracture is allowed to heal. However, these compression providing devices must be securely and removably attached to the intramedullary device while not compromising the integrity of the intramedullary device or the ability of the compression device to provide appropriate compression. In some cases, a drill guide must also be securely and removably attached to the intramedullary device.

15

20

Thus, there remains a need for an intramedullary device assembly that is easy to install without the need for extensive surgical dissection, and provides appropriate compression of the bone to promote healing.

25

BRIEF SUMMARY OF THE INVENTION

The present invention generally related to an intramedullary device for repairing defects of a bone. Advantageously, in one embodiment, the intramedullary device is configured to be inserted into the medullary canal of a bone and includes a stud
5 extending from the exposed end. The stud includes a portion that is tapered from a first, smaller cross-sectional area where the stud attaches to the intramedullary device, to a second, larger cross-sectional area. The first, smaller cross-sectional area provides a region of stress concentration. The stud also includes an externally threaded portion configured to engage the internal threads of a fastener retained within a guide adapter.
10 The external threads of the stud engage the internal threads of the fastener to secure the intramedullary device to the guide adapter when a first torque is applied to the internally-threaded fastener. The first torque may be limited by a torque-limiting driver. Upon completion of insertion, compression and securing of the intramedullary device in the medullary canal of the bone, the intramedullary device can be separated from the guide
15 adapter by applying a second, greater torque to the internally-threaded fastener whereby the stud breaks free of the intramedullary device at the region of concentrated stress.

In one embodiment, an intramedullary device assembly includes an intramedullary device and a guide adapter. The guide adapter includes a bone engagement member
20 guide configured to attach to an end of the intramedullary device, a compression member, and a bone engagement member. The compression member and the bone engagement member are movable along the bone engagement member guide. The intramedullary device is configured to be inserted into the medullary canal of the bone and fastened to the bone on either side of the defect. Thus, application of force on the bone engagement member by the compression member in the direction of the bone
25 advances the bone engagement member along the bone engagement member guide such that the bone engagement member engages the end of the bone. In some embodiments, the bone engagement member guide defines an elongated void, and the bone engagement member includes an internal part and an external part. The internal part is movably retained within the bone engagement member guide and the external part
30 engages the bone. The compression member may be configured to apply force to the internal part of the bone engagement member while the external part transmits the compressive force to the bone. The guide adapter may, in some cases, be configured to attach to a drill guide. The guide adapter may define a keyway slot configured to permit alignment of the drill guide with respect to the intramedullary device assembly.

35 In one embodiment, the intramedullary device assembly includes an intramedullary device and a guide adapter. The guide adapter may include a bone engagement member guide, a compression member, and a bone engagement member.

The intramedullary device is configured to be inserted into the medullary canal of the bone and fastened to the bone on either side of the defect. The bone engagement member guide is configured to attach to an end of the intramedullary device. The compression member and the bone engagement member may be configured to be
5 movable along the bone engagement member guide. The bone engagement member includes at least two bone engagement points, where at least one bone engagement point is movable along an axis of the bone engagement member guide relative to at least one other bone engagement point and is configured to engage an end of the bone. Thus, application of force on the bone engagement member by the compression member in the
10 direction of the bone advances the bone engagement member along the bone engagement member guide such that the at least one bone engagement point of the bone engagement member is permitted to move relative to the other at least one bone engagement point so that both bone engagement points can securely engage the end of the bone.

15 In some embodiments, the bone engagement member guide defines an elongated void, and the bone engagement member includes an internal part and an external part. The internal part is configured to be movably retained within the bone engagement member guide, and the external part is configured to extend outside of the bone engagement member guide and engage the end of the bone via at least one of the bone
20 engagement points. The compression member may be configured to apply force to the internal part of the bone engagement member, and the external part of the bone engagement member may include one or more pressing elements configured to engage the end of the bone. The external part of the bone engagement member may, in some cases, include at least two pressing elements, and at least one of the pressing elements
25 may be shorter than the other pressing elements. The guide adapter of the intramedullary device assembly may, in some cases, be configured to attach to a drill guide. The guide adapter may define a keyway slot configured to permit alignment of the drill guide with respect to the intramedullary device assembly.

30 In some embodiments, the intramedullary device may include a breakaway stud attached to the intramedullary device and connecting to a bone engagement member guide. The breakaway stud is configured to break away from the intramedullary device when more than a threshold amount of force is applied to the stud. In some cases, this breakaway action may occur after the bone engagement member guide has been detached from the intramedullary device; however the breakaway stud may also be
35 configured to break away from the intramedullary device while the bone engagement member guide is still in the attached position. The breakaway stud may also be configured to fit in a corresponding recess in the bone engagement member guide where

it may be engaged by a fastener to retain the breakaway stud within the bone engagement member guide. The intramedullary device may define a recess to accept an alignment tab from the bone engagement member guide. The intramedullary device may further define a nub having a circumferential lip between the breakaway stud and the intramedullary device to at least partially engage the bone engagement member guide.

One embodiment of the breakaway stud may have external threads configured to engage the internal threads of a fastener that is retained within the bone engagement member guide. The bone engagement member guide may further be configured to provide a shoulder on which the head of the internally-threaded fastener rests retaining the internally-threaded fastener within the bone engagement member guide. The threaded breakaway stud may be inserted into the bone engagement member guide and engage the internal threads of the fastener retained within the bone engagement member guide such that when the fastener is turned, the breakaway stud is drawn in to the bone engagement member guide until the intramedullary device securely abuts the bone engagement member guide. The internally-threaded fastener may be configured to receive the application of a first torque to achieve a secure fit between the intramedullary device and the bone engagement member guide. The first torque may be applied by a torque-limiting T-handle driver or device to prevent over-torquing the internally threaded fastener and breaking the breakaway stud prematurely. Once the intramedullary device is securely attached to the bone engagement member guide, the surgical procedure may commence. After the intramedullary device is securely fastened within the compressed bone; a second torque, greater than the first torque, may be applied to the internally-threaded fastener, whereupon the breakaway stud breaks away from the intramedullary device thereby disconnecting the intramedullary device from the bone engagement member guide. The second torque may be applied with a standard, non torque-limiting T-handle driver or device. Optionally, the first torque and the second torque may each be applied with a separate torque-limiting driver wherein each of the two torque limiting drivers is pre-set with the desired torque value.

The breakaway stud may be configured with a tapered base that attaches to the intramedullary device resulting in a stress concentration area at the interface of the breakaway stud and the intramedullary device. The breakaway stud may further be configured with a medial portion between the tapered base and the threaded portion. The medial portion may comprise one or more flat facets that are configured to be gripped by a tool, such as pliers, a wrench, a hexagonal socket, or a custom tool with a keyway among others, such that the threaded stud may be removed from the internally-threaded fastener of the bone engagement member guide, allowing the bone engagement member guide to be used again with another intramedullary device.

A drill guide may also be attached to the guide adapter, where the drill guide is configured to allow drilling holes through the bone that are in alignment with corresponding holes defined by the intramedullary device. Furthermore, attaching the guide adapter to the proximal end of the intramedullary device may include providing a breakaway stud at the proximal end of the intramedullary device and attaching the first end of the bone engagement member guide of the guide adapter to the breakaway stud. In some cases, the bone engagement member guide may be engaged with a lip formed on a nub defined by the proximal end of the intramedullary device, disposed between the breakaway stud and the remainder of the intramedullary device.

Another method for detaching the intramedullary device from the intramedullary assembly may include detaching the bone engagement member guide and the compression member from the intramedullary device by disengaging the internally-threaded fastener from the externally threaded breakaway stud. The breakaway stud may subsequently be disconnected from the intramedullary device by cutting, bending/snapping, or using a second internally-threaded fastener. In some embodiments, a second internally-threaded fastener may be configured to engage the breakaway stud. As the second internally-threaded fastener is tightened, the end may seat against the intramedullary device and pull the breakaway stud while pushing against the intramedullary device until the breakaway stud is separated from the intramedullary device at the region of concentrated stress.

In other embodiments, an intramedullary device and breakaway stud for attaching an intramedullary device to a guide adapter are provided. The intramedullary device is configured to be inserted into the medullary canal of a bone and fastened to the bone on either side of a defect. The breakaway stud includes a proximal portion and a distal portion, where the proximal portion is configured to engage a bone engagement member guide of the guide adapter and the distal portion is configured to engage the intramedullary device. The distal portion includes a region of concentrated stress such that force applied to the breakaway stud is focused in the region of concentrated stress and causes the breakaway stud to break at or near the region of concentrated stress, thereby detaching the breakaway stud from the intramedullary device.

In some embodiments, the proximal portion of the breakaway stud is cylindrical with a helical thread and the distal portion of the breakaway stud may be tapered. The distal portion may taper or step down to a cross-sectional area that is smaller than other cross-sectional areas of the breakaway stud to form a region of concentrated stress. Between the proximal, threaded portion and the distal, tapered portion may be a medial portion with a polygonal cross-section or a generally circular cylindrical cross-section with at least one flat facet. The section may be a rectangular cross section resulting in four

facets or a hexagonal cross section resulting in six facets along the medial portion of the breakaway stud.

5

BRIEF DESCRIPTION OF THE SEVERAL VIEWS OF THE DRAWING(S)

Having thus described the invention in general terms, reference will now be made to the accompanying drawings, which are not necessarily drawn to scale, and wherein:

10 FIG. 1A is an expanded perspective view of an intramedullary device assembly according to one embodiment;

FIG. 1B is an illustration of an intramedullary device with chamfered hole openings according to one embodiment;

FIG. 2A is an illustration of an intramedullary device assembly installed in an ulna according to one embodiment;

15 FIG. 2B shows engagement of a bone engagement member having pressing elements of equal length with a bone surface according to one embodiment;

FIG. 2C shows engagement of a bone engagement member having pressing elements of unequal length with a bone surface according to another embodiment;

20 FIG. 3 is a side view of a guide adapter with pressing elements according to one embodiment;

FIG. 4 is an expanded side view of a bone engagement member guide including multiple components according to one embodiment;

FIG. 5A is a side view of a guide adapter and compression member according to one embodiment;

25 FIG. 5B is a perspective view of the bone engagement member according to the embodiment of FIG. 5A;

FIG. 6A is a partial side view of an installed intramedullary device assembly achieving compression according to one embodiment;

30 FIG. 6B is a partial side view of an installed intramedullary device of FIG. 6A after desired compression has been achieved and the guide adapter and compression member have been detached;

FIG. 7A is a perspective view of an intramedullary device assembly with attached drill guide according to one embodiment;

35 FIG. 7B is a close-up perspective view of a connecting section of the drill guide of FIG. 7A;

FIG. 7C is a perspective view of the drill guide with a cannula adapted to be used as a drill depth gauge;

FIG. 8 is an expanded perspective view of an intramedullary device assembly including a breakaway stud according to one embodiment;

FIG. 9A is a close-up perspective view of the breakaway stud of FIG. 8;

FIG. 9B is a side plan view of the breakaway stud of FIG. 9A;

5 FIG. 9C is a side plan view of the breakaway stud and nub within the guide adapter;

FIG. 9D is a side plan view of the breakaway stud and nub of FIG. 9C;

FIG. 10A is a perspective view of the intramedullary device and guide adapter showing the tab of the guide adapter according to one embodiment;

10 FIG. 10B is a perspective view showing the intramedullary device, breakaway stud, and guide adapter of FIG. 10A in an assembled configuration; and

FIG. 10C is a perspective view showing the guide adapter in cross section, the internally-threaded fastener, the intramedullary device, and the breakaway stud.

15 DETAILED DESCRIPTION OF THE DRAWINGS

The present invention now will be described more fully hereinafter with reference to the accompanying drawings, in which some, but not all embodiments of the invention are shown. Indeed, the invention may be embodied in many different forms and should not be construed as limited to the embodiments set forth herein; rather, these
20 embodiments are provided so that this disclosure will satisfy applicable legal requirements. Like numbers refer to like elements throughout.

Embodiments of the present invention generally relate to an intramedullary device assembly for repairing fractures, osteotomies, and other defects of a long bone or periarticular bone. For ease of explanation, however, the specification and
25 accompanying figures will refer to bone fractures, although it is to be understood that any type of bone repair, including the repair of fractures, osteotomies, and other bone defects, and combinations thereof, may be accomplished using embodiments of the device described herein.

As described further below, the intramedullary device assembly includes an
30 intramedullary device that is configured to be inserted into the medullary canal of the fractured bone. A guide adapter that includes a bone engagement member guide attaches to the end of the intramedullary device and includes a movable bone engagement member configured such that a compression member attached to the guide adapter at an opposite end from the device can push the bone engagement member to
35 engage the end of the bone. By fastening the installed intramedullary device to the bone segment on a distal side of the fracture and then applying compression via the compression member and bone engagement member, the fastened bone segment may

be pushed towards the bone segment on the proximal side of the fracture. Once the desired compression is achieved, the proximal bone segment may be fastened to the intramedullary device, and the guide adapter and compression member may be detached from the device so that the patient may be able to use the affected joint to a greater extent during the healing process. In this regard, the terms "proximal" and "distal" refer to locations of the bone and assembly relative to the insertion site of the assembly after it has been inserted into the bone. In other words, the proximal side of the fracture refers to a segment of bone closer to the site at which the intramedullary device assembly was inserted; the distal side of the fracture refers to a segment of bone farther from the insertion site, and so on. Thus, for ulnar applications at the olecranon, the terms proximal and distal will coincide with those terms as used to describe the human body. However, for ankle applications, for example, the terms will be reversed.

The compression member may be pre-adjusted such that the bone engagement member may be pushed against the proximal fragment as the intramedullary device is advanced into the medullary canal, as described below. In this way, at least partial compression at the fracture site may be provided without changing the position of the intramedullary device within the proximal fragment. Also in this way, the alignment of the bone segments may be provisionally held by the bone engagement member until more definitive fasteners are placed.

Referring to Fig. 1A, an intramedullary device assembly **10** according to one embodiment is shown in an expanded view. The assembly **10** includes an intramedullary device **12**, a guide adapter **14**, and a compression member **16** that may be attached end-to-end to treat a fracture, as described below. The intramedullary device **12** is configured (i.e., shaped and sized) to be inserted into the medullary canal of a bone and fastened to the bone on either side of the fracture. Thus, the particular configuration of the intramedullary device **12** may vary depending on the type and size of the bone to be treated. For example, an intramedullary device **12** to be used for fixing a fracture of an adult femur may have different dimensions and may be shaped differently than a device **12** to be used for fixing a fracture of a child's radius. Furthermore, the device **12** may be made of any absorbable or non-absorbable material that is compatible for use inside the human body, such as titanium, stainless steel, cobalt chrome, plastic, carbon fiber, or polymer.

In the embodiment shown in Fig. 1A, for example, the intramedullary device **12** is configured for use in an adult ulna via insertion through the olecranon. However, the intramedullary device **12** and assembly **10** may be used in various other locations in the human body, such as for repairing a fracture of the lateral malleolus (distal fibula) at the ankle. The intramedullary device **12** of Fig. 1A is tapered, with the proximal end (i.e., the

end closest to the olecranon when installed) having a slightly larger diameter than the distal end (i.e., the end farthest from the olecranon when installed). Also, the intramedullary device may be tapered in the reversed manner or remain uniform in diameter throughout its length. Its axis may be straight, as shown in Fig. 1A, or curved.

5 An ulna **18** and an olecranon **20** are illustrated in Fig. 2A, which shows an installed assembly **10** according to one embodiment. Referring again to Fig. 1A, the intramedullary device **12** may include a number of holes **22** configured to receive fasteners for fastening segments of bone to the intramedullary device **12**. One or more of the holes **22** may be located towards the distal end of the intramedullary device **12**, for
10 example to fasten a bone segment that is on a distal side of the fracture to the intramedullary device **12**, whereas one or more other holes **22** may be located towards the proximal end of the intramedullary device **12**, for fastening another bone segment that is on a proximal side of the fracture, as discussed below. Furthermore, the holes **22** may be configured to receive various types of fasteners, such as pins, bolts, pegs, screws,
15 and locking screws, among others. In some cases, the holes **22** may be internally-threaded to receive corresponding externally threaded fasteners. As shown in Fig. 1B, the holes **22** may have a chamfered opening **23** on the side configured to receive a corresponding fastener which may aid insertion of the fastener by providing a larger opening to accept and guide the fastener.

20 The guide adapter **14** of the assembly **10** includes a bone engagement member guide **24** and a bone engagement member **26**, shown assembled according to one embodiment in Fig. 3. The bone engagement member guide **24** is configured to attach to an end of the intramedullary device **12**, namely at the proximal end of the device **12**, and to retain at least part of the bone engagement member **26** within the bone engagement
25 member guide **24**. For example, in the embodiment shown in Fig. 3, the bone engagement member **26** includes an internal part **28** that is configured to be movably retained within the bone engagement member guide **24** and an external part **30** that is configured to extend outside of the bone engagement member guide **24** and engage the end of the bone, as described below. In some cases, the guide adapter bone
30 engagement member guide **24** defines an elongated void **32**, such as within a cannulated portion of the bone engagement member guide, to allow the bone engagement member **26** to move along the bone engagement member guide **24**. The bone engagement member guide **24** may further include a fastener such as the internally-threaded fastener **75** shown in Figs. 9C, 10B, and 10C. The bone engagement member **26** of the guide
35 adapter **14** is configured to engage the end of the bone into which the intramedullary device **12** is inserted, as illustrated in Figs. 2A and 6A. It is to be understood that the

bone engagement member **26** may engage directly against the bone itself, soft tissue connected to the bone, or any other material found on the surface of the bone.

The bone engagement member includes at least two bone engagement points configured to engage the end of the bone. In Fig. 3, for example, the bone engagement points comprise the ends of the pressing elements **40**, which are illustrated as three prongs, and which extend from the internal part **28** of the bone engagement member **26** towards the end of the bone. However, in other embodiments, the bone engagement points may be points on a continuous surface, such as two or more points on a single bone engaging element. For example, the bone engagement member **26** could comprise a flat ring or horseshoe-shaped pad depending from the internal part **28**, and at least two separate geometrical points on this pad would be movable relative to each other in an axial direction when the bone engagement member tilts relative to the bone engagement member guide **24**. In any case, at least one of the bone engagement points is permitted to move axially relative to at least one other bone engagement point such that it can more easily and securely engage the bone. As noted, the bone engagement member **26** may be tiltable with respect to an axis **X** of the bone engagement member guide **24**, such that the bone engagement member **26** may tilt in any direction in order to engage a bone surface that may not be perpendicular to the **X**-axis, as indicated by the curved arrows in Fig. 3. An example of this is illustrated in Fig. 6A. In other embodiments, the bone engagement points may be defined on structures that are configured to bend, rotate and/or telescope (with or without tilting) in order to engage the end of the bone in a desirable orientation so that the compression forces applied may be more balanced.

Referring to Fig. 4, the bone engagement member guide **24** may include more than one part that fit together or are otherwise connected to form the bone engagement member guide **24** around the bone engagement member (not shown). For example, the bone engagement member guide **24** may include a base portion **34** and an upper portion **36** that are welded together or otherwise fixedly attached after the bone engagement member **26** (shown in Fig. 3) or a portion thereof is placed within the base portion **34**. In this regard, the base portion **34** may include one or more slots **38** through which the external part **30** of the bone engagement member **26** is configured to pass through. In the embodiment illustrated in Fig. 3, for example, three slots **38** (one visible) are defined in the base member **34**, and the external part **30** of the bone engagement member **26** includes three pressing elements **40** that are configured to engage the end of the bone. Furthermore, at least one of these pressing elements **40** may be shorter than the other pressing elements in order to enhance the strength or stability of the engagement between the pressing elements and the end of the bone. In other words, differences in the length of the pressing elements may allow the pressing elements to conform to the

angled surface of the bone while limiting the extent to which the bone engagement member must tilt to engage the bone. Thus, the angle of the internal part **28** of the bone engagement member **26** may remain closer to 90° with respect to the **X**-axis, providing for a more secure engagement with the bone. This is illustrated in Figs. 2B and 2C, where the angle α (corresponding to pressing elements of equal length) is greater than the angle β (corresponding to pressing elements of unequal length). In other embodiments, the external part **30** may be configured differently.

The base portion **34** of the bone engagement member guide **24** may further include grooves **35** that provide a visual reference to a surgeon of how far the bone engagement member **26** has advanced towards the bone. For example, the grooves **35** may be equidistantly spaced at a certain interval, such as 1 mm apart. In this case, advancement of the bone engagement member **26** past 3 grooves would indicate that the bone engagement member **26** has advanced 3 mm.

Referring again to Fig. 1A, the compression member **16** of the assembly **10** is configured to attach to an end of the bone engagement member guide **24**, opposite the end of the bone engagement member guide **24** that attaches to the intramedullary device **12**. In some embodiments, the compression member **16** includes a pushing member **44**, which may be integral to the compression member **16**, as shown in Fig. 1A, or may be formed separately and subsequently attached to the compression member **16**, for example via a welded or threaded connection. Regardless, the compression member **16** is movable along the bone engagement member guide **24** and is configured to move the bone engagement member **26** into engagement with the end of the bone (e.g., via the pushing member **44**).

For example, Fig. 5A shows a close-up view of the guide adapter **14** with the compression member **16** attached according to the embodiment illustrated in Fig. 1A. In this example, the upper portion **36** of the bone engagement member guide **24** may include an internally-threaded region **46**, and the compression member **16** may include a corresponding externally threaded region **48** that is configured to mate with the internal threads **46** of the bone engagement member guide **24**. In this way, rotation of the compression member **16**, such as by turning a handle **50** as indicated by the arrow, would serve to advance the compression member **16** and pushing member **44** farther into the bone engagement member guide **24**, towards the bone engagement member **26**. The handle **50** may have various configurations. For example, the handle **50** depicted in Fig. 1A has a "T" configuration, whereas the handle **50** depicted in Fig. 7A has a knob configuration. Optionally, the pushing member **44** may be pushed with or without a compressive member **16** manually or by electronic motor through the bone engagement member guide **24** toward the bone engagement member **26**. There may be a locking

mechanism between the compressive member **16** and/or pushing member **44** and the bone engagement member guide **24** to maintain the position of the compression member **16** against the bone engagement member **26**.

In an installed assembly **10** (shown in Fig. 6A), continued application of force by the pushing member **44** on the bone engagement member **26**, for example, by continued rotation of the handle **50** after engagement of the bone engagement member **26** with the pushing member **44** and the bone, would serve to advance the bone engagement member **26** farther along the bone engagement member guide **24** in the direction of the intramedullary device **12**. As a result, the intramedullary device **12**, along with any attached bone segments, would be moved in the opposite direction (i.e., towards the compression member **16**), thereby achieving compression as shown in Fig. 6A. In some embodiments, such as the one illustrated in Fig. 5A, the compression member **16** (e.g., via the pushing member **44**) is configured to apply force to the internal part **28** of the bone engagement member **26**. Fig. 5B shows the bone engagement member of Fig. 5A as it appears without the bone engagement member guide **24**.

The guide adapter **14** of the intramedullary device assembly **10** may be configured to attach to a drill guide **52**, as illustrated in Fig. 7A. The drill guide **52** may be configured in various ways, depending on the configuration of the intramedullary device **12**, the type of drill used (not shown), the doctor's preference, aesthetic appeal, durability and radiolucency of the materials, and other considerations. According to one embodiment, the drill guide **52** is formed of carbon fiber, though other materials, such as a radiolucent plastic material may also be used. In general, the drill guide **52** may include cannulas **54** configured to guide the drill bit or other instruments used to secure fasteners to the bone in which the intramedullary device assembly **10** is installed. For example, in the treatment of a fractured ulna, the drill guide **52** may surround the patient's elbow and forearm once the assembly **10** is installed, and the drill bit may be inserted through a cannula **54** in order to maintain the angle at which the drill bit approaches the bone to facilitate proper drilling. Furthermore, the cannula **54** may act as a soft-tissue protector as it buries itself in the soft tissue (e.g., of the forearm) through minimally invasive puncture incisions and rests against the bone. This allows the drill bit to pass through and engage the bone without damaging the surrounding soft tissue structures. Each cannula **54** may be movable between guide holes **56** at various locations defined by the drill guide **52**. In this regard, the guide holes **56** may be configured to be aligned with the holes **22** of the intramedullary device **12** (Fig. 1A), such that positioning the cannula **54** at a guide hole **56** facilitates the drilling of a hole through the bone that is aligned with a device hole **22**, and a fastener may then be inserted to affix the drilled bone to the device **12**. The drill guide cannulas **54** may further be configured to indicate the depth of the drill

bit during the drilling operation by using depth indicating markings **57** on the cannula **54** as shown in Fig. 7C and possibly using a drill bit that is configured with depth markings that may be read at the entrance to the cannula **54**.

The drill guide **52** may be attached to the guide adapter **14** in many ways. For example, referring to Figs. 4, 7A, and 7B, the drill guide **52** may have a circular void in the connecting section **53** (shown in Fig. 7A) that is configured to slide over a corresponding part of the upper portion **36** of the bone engagement member guide **24** (shown in Fig. 4). A hex nut **58** or other type of end fastener may then be attached to the end of the upper portion **36**, such as via external threads **59** on the upper portion **36** or via welding, to hold the drill guide **52** in place. Optionally, the drill guide **52** and the guide adapter **14** may be fabricated from single piece of material so that the drill guide **52** and guide adapter **14** are monolithic, rather than separately connected parts.

Furthermore, the bone engagement member guide **24** may define a keyway slot **60** (Fig. 4), for example in the upper portion **36**, that is configured to permit alignment of the drill guide with respect to the bone engagement member guide **24** and the assembly **10** in general. In this case, the drill guide **52** would have a corresponding extension **62** formed in the void of the connecting section **53** (rather than a perfectly circular void for sliding onto the upper portion **36**), as shown in Fig. 7B, that is configured to fit into the keyway slot **60** such that the drill guide **52** will only be received by the upper portion **36** in the proper orientation (i.e., with the extension **62** aligned to fit into the keyway slot **60**). Alternatively, a separate adapter key **63** in the form of a rectangular bar, as shown in Figs. 1A and 8, may be provided to prevent rotation of the guide adapter **14** relative to the drill guide **52**. In this regard, a rectangular cross-section groove or slot that is aligned with the axis of the guide adapter **14** is milled in the outside surface of upper portion of the guide adapter **14**. A corresponding slot is milled or broached into the drill guide **52** to be affixed to the guide adapter **14**. The adapter key **63** may then be put into the slot of the guide adapter **14** such that it protrudes from the surface, as shown in the figures, and is able to engage the corresponding slot in the drill guide **52**, thereby preventing rotation of the guide adapter **14** relative to the drill guide **52**.

In some cases, such as in the embodiment of Fig. 7A, the drill guide **52** may include an external rotation guide **86** to provide a surgeon with a way to determine whether the intramedullary device **12** is being inserted into the medullary canal in the proper rotational orientation. If the device **12** is not at the proper rotation, some of the fasteners may be placed in suboptimal (or even deleterious) positions with respect to certain fracture types. The external rotation guide **86** may, for example, have an "X" configuration such that it may be used on different bones in the body. For instance, installing the intramedullary device **12** on a right elbow may require the surgeon to use

one of the lines of the "X" for alignment, whereas installing the intramedullary device **12** on a left elbow may require the surgeon to use the other line. The cross-members of the "X" may be of square or rectangular cross section allowing an identifier such as "right" or "left" to be printed or etched onto each of the cross-members. Once the intramedullary device **12** is inserted into the canal, prior to drilling for screws, the proper rotation may be confirmed by lining up the plane of the external rotation guide **86** with the axis between the humeral epicondyles (in this example). The axis in this case should be approximately 10° from the horizontal relative to the joint line of the ulnohumeral joint. If the device **12** is rotated inappropriately, the respective line of the "X" will appear tilted away from the axis of the epicondyles, warning the surgeon that the position of the device **12** needs readjustment prior to drilling. The external rotation guide **86** may be removable (e.g., if the surgeon prefers other methods of confirming rotational alignment), and the position of the external rotation guide **86** may be adjustable such that it may be raised or lowered to correspond to the humeral epicondylar axis of the particular patient.

Referring to Figs. 3, 4, and 10A, the guide adapter **14** may also include a tab **64** or other protrusion configured to engage the intramedullary device **12** to limit rotation of the guide adapter **14** with respect to the intramedullary device **12**. In this regard, the tab **64** may be configured to fit in a corresponding recess **65** in the attachment end of the intramedullary device **12** such that the guide adapter **14** and the intramedullary device **12** may only be attached when the tab **64** is aligned with the corresponding recess **65**, and, once attached, torsion and bending forces across the junction may be controlled. Optionally, the intramedullary device **12** may include a tab or other protrusion configured to engage a corresponding recess in the guide adapter **14** to limit rotation of the guide adapter **14** with respect to the intramedullary device **12** and to control torsion and bending forces across the junction. When the guide adapter **14** and the intramedullary device **12** are assembled, the tab **64** and recess **65** may align the intramedullary device **12** with the guide adapter **14** and may also align a drill guide **52** such that each fastener hole **22** in the intramedullary device **12** aligns with the drill guide holes **56** as shown in FIG. 7A. The tab **64** and recess **65** may be of complimentary shape with a rounded end to aid alignment as the intramedullary device **12** and the guide adapter **14** are secured together.

In some embodiments, such as the one illustrated in Fig. 8, the intramedullary device **12** includes a breakaway stud **66** for connecting the intramedullary device **12** and the guide adapter **14**. The breakaway stud **66** is configured to break away from the intramedullary device **12** when a predetermined amount of force is applied to the breakaway stud **66**. Referring to Figs. 9A and 9B, for example, the breakaway stud **66** may include a proximal portion **68**, a medial portion **76**, and a distal portion **70**. The proximal portion **68** may have an external thread and may be configured to engage an

internally-threaded fastener **75** (shown in FIGS. 9C and 10C) retained within the bone engagement member guide **24**. A driving device (not shown) may be inserted through the guide adapter **14** to engage the head of the internally-threaded fastener **75**. A first torque can then be applied to the internally-threaded fastener **75**, and the intramedullary device **12** may be secured to the guide adapter **14** as illustrated in FIGS. 9C, 10A, 10B, and 10C. The first torque may be limited by a torque-limiting T-handle driver or device to prevent over-torquing of the internally threaded fastener. As shown in FIGS. 9C and 10C, a shoulder **77** may be provided within the bone engagement member guide **24** such that as the fastener **75** is tightened, the head of the internally-threaded fastener **75** may press against the shoulder **77**, drawing the intramedullary device **12** and the guide adapter **14** together.

The medial portion **76** of the breakaway stud **66** may be configured with at least one flat facet around the perimeter, as shown in FIG. 10C to allow a tool to engage and secure the breakaway stud **66** once the breakaway stud is removed from the intramedullary device **12**. Thus the breakaway stud **66** may be disengaged from the internally-threaded fastener **75** and removed from the guide adapter **14**. In this way, the internally-threaded fastener **75** and the guide adapter **14** can be used with a new intramedullary device **12** in another operation. The medial portion **76** may have any number of facets, though embodiments having either four or six facets may easily be engaged by standard tools such as pliers, a wrench, or a hexagonal socket.

The distal portion **70** may be configured to engage the intramedullary device and can include a region of concentrated stress **72** that allows the force applied to the breakaway stud **66** to be focused in the region of concentrated stress **72** and causes the breakaway stud **66** to break at or near the region of concentrated stress **72**. The distal portion **70** may be configured in various ways. For example, as shown in Fig. 9B, the distal portion **70** may be conically-shaped and may be tapered. Thus, in the embodiment of Fig. 9B, the region of concentrated stress **72** may be the region where the cross-sectional area of the tapered portion **70** is smallest. The distal portion **70** may also be faceted and tapered rather than conical in shape. Alternatively, the region of concentrated stress **72** may include a "shark-bite" or other type of reduction in cross-section, and is not necessarily tapered. In this way, once the assembly **10** has been installed in the medullary canal of the fractured bone, compression of the fracture has been achieved, and the bone segments of the fracture have been fastened to the intramedullary device **12** such that the fracture can heal, a second torque may be applied to the internally-threaded fastener **75** (as shown in Fig. 9C), greater than the first torque, resulting in a pulling force across the region of concentrated stress **72** that breaks the breakaway stud **66** free from the intramedullary device **12**. The second torque may be applied with a

standard, non-torque-limiting T-handle driver or device and optionally, the first torque and second torque may be applied by a first torque-limiting driver and second torque-limiting driver respectively, wherein each torque-limiting driver is pre-set with the desired torque value. For example, the internally-threaded fastener **75** may be seated on the shoulder **77**
5 within the guide adapter **14**, and as the internally-threaded fastener **75** is turned, the breakaway stud **66** may be drawn into the guide adapter **14** with enough force to separate the breakaway stud **66** from the intramedullary device **12**. This separates the guide adapter from the installed intramedullary device **12**, leaving the intramedullary device **12** installed in the bone to facilitate healing while at the same time allowing the
10 patient to use the affected joint and bone to the extent possible. In some embodiments, the breakaway stud **66** may be broken away before the guide adapter **14** is removed from the intramedullary nail **12**.

One of ordinary skill in the art would appreciate that the second torque is greater than a threshold force where the threshold force is greater than the force required to
15 secure the breakaway stud **66** within the guide adapter **14** (i.e., the first torque) but less than a force that would cause damage to the patient or would result in failure of the intramedullary device assembly **10** at a location other than at the region of concentrated stress **72**. The threshold force may also be achieved by bending or twisting the breakaway stud **66** when the stud is not engaged with the guide adapter **14**.

20 In some cases as shown in FIGS. 9D and 10C, the region of concentrated stress **72** may include a countersink or undercut **71** in the distal portion **70** where the breakaway stud **66** attaches to the intramedullary device **12** such that upon detachment (i.e., breaking of the breakaway stud **66**), any residual portion of the stud **66** that remains attached to the intramedullary device **12** is recessed into the device **12**. In this way, the
25 residual stud is less palpable to the patient and the potential for soft tissue irritation is reduced.

In some embodiments, the proximal end of the intramedullary device **12** may define a short stump or nub **13** for attaching the breakaway stud **66**, as shown in Figs. 8 and 9B. The nub **13** may have a circumferential lip **15** that fits partially into the bone engagement member guide of the guide adapter **14** so as to offset some of the bending
30 forces that the intramedullary device **12** may experience during installation in the bone. Furthermore, the lip **15** may allow for the intramedullary device **12** to be manipulated after installation, for example to facilitate removal of the intramedullary device **12** from the bone if removal becomes necessary or desirable. The guide adapter **14** may include a
35 ridge **21** around the circumference, or a similar indicator, to indicate the location of the end of the nub **13** within the guide adapter **14** as shown in Fig. 9C. This ridge or marking

would serve to indicate the depth to which the intramedullary device **12** must be inserted to prevent the nub **13** from protruding from the end of the bone.

In other embodiments, a method for assembling an intramedullary device assembly for repairing a defect (or defects) of a bone is provided. Referring to Fig. 1A, initially, an intramedullary device **12** configured to be inserted into a medullary canal of a bone is provided. As previously described, the intramedullary device **12** may have various configurations, depending on the location and type of bone as well as other considerations. The medullary canal of the bone may, in some cases, be prepared beforehand for receiving the intramedullary device **12** using tools and methods known by those skilled in the art, such as by drilling out the medullary canal so that the dimensions of the medullary canal correspond to the dimensions of the intramedullary device **12**. The intramedullary device **12** may then be inserted into the prepared medullary canal of the bone. For example, referring to Fig. 2A, the intramedullary device **12** may be inserted into the medullary canal of a fractured ulna **18** through the metaphyseal end of ulna, or the olecranon **20**. As another example, the intramedullary device **12** may be inserted into the medullary canal of a fractured fibula through the metaphyseal end of the fibula, the lateral malleolus, the medial malleolus, the calcaneus, patella, or across a joint to achieve fusion. The intramedullary device may also be configured so that it cuts its own path into the bone with or without the assistance of accessory tools.

Referring again to Fig. 1A, the guide adapter **14** is attached to a proximal end of the intramedullary device **12**, either before or after insertion of the intramedullary device **12** into the medullary canal. As previously described, the guide adapter **14** includes a bone engagement member guide **24** having a first end configured to attach to the proximal end of the intramedullary device **12** and a bone engagement member **26** that is movable along the bone engagement member guide **24** and includes at least two bone engagement points. At least one bone engagement point is movable along an axis of the bone engagement member guide **24** relative to at least one other bone engagement point and is configured to engage an end of the bone. For example, the bone engagement member guide **24** may be tiltable with respect to an axis **X** of the bone engagement member guide **24**, as shown in Figs. 2A, 2B, and 2C, or one or more of the bone engagement points may be defined on a structure, such as a discrete pressing element, that can bend, rotate, or telescope to engage the bone.

As described above, the bone engagement member guide **24** may be made up of one or more components. The bone engagement member **26** of the guide adapter **14** is configured to engage the end of a bone. For example, in Fig. 3, the bone engagement member **26** includes multiple pressing elements **40** configured to engage the surface of the end of the bone (as illustrated in Figs. 2A and 6A). Turning again to Fig. 1A, a

compression member **16**, which is movable along the bone engagement member guide **24**, is attached to the second end of the bone engagement member guide **24** (for example, as shown in Fig. 5A).

5 A drill guide **52**, shown in Fig. 7A, may also be attached to the guide adapter **14**, for example, as previously described with reference to Figs. 4 and 7A. The drill guide **52** may be configured to allow the drilling of holes through the bone (i.e., through the patient's soft tissues and into the bone) such that the drilled holes are in alignment with corresponding holes defined by the intramedullary device **12**. In this way, fasteners such as screws, pegs, bolts, pins or other fasteners may be inserted through the holes in the
10 bone and received by the corresponding holes in the intramedullary device to hold the bone to the intramedullary device in those locations.

In some embodiments, such as the embodiment of Figs. 8 and 9A, a breakaway stud **66** may be used to attach the guide adapter **14** to the proximal end of the intramedullary device **12**. In this regard, one end of the breakaway stud **66** may be
15 attached to the proximal end of the intramedullary device **12**, and the other end of the breakaway stud **66** may be attached to the first end of the bone engagement member guide **24**. As described above, the guide adapter **14** may be configured to engage the breakaway stud **66** by engaging an internally-threaded fastener **75** retained within the guide adapter **14** with the external threads **68** of the breakaway stud **66** as shown in Fig.
20 9C.

Once the intramedullary device assembly **10** is assembled and installed in the medullary canal of the affected bone, regardless of the order of the steps, compression may be applied to bring the bone segments on either side of the fracture together, thereby promoting the healing of the bone. According to one embodiment of a method of
25 applying compression, the intramedullary device is inserted into a medullary canal of the bone, for example, as previously described. Referring to Fig. 6A, the intramedullary device **12** is fastened to a distal segment **80** of the bone (a segment located on the distal side of the bone defect relative to the intramedullary device assembly). For example, one or more locking screws **82** may be inserted through intramedullary device holes **22**
30 (shown in Figs. 1A and 8) to hold the distal segment **80** to the intramedullary device **12**.

Compression may then be applied by advancing the compression member **16** towards the intramedullary device and bone (illustrated in Fig. 5A and indicated by the downward arrow) and into engagement with the bone engagement member **26**. For example, in Fig. 5A, the handle **50** of the compression member **16** may be rotated to
35 advance the pushing member **44** into engagement with the bone engagement member **26**. As a result, the bone engagement member **26** advances towards the bone, engages the end of the bone, and continues to advance along the bone engagement member

guide towards the intramedullary device **12**, as illustrated in Fig. 6A, such that the distal segment **80** is moved towards the proximal segment **84** of the bone (i.e., the segment of bone located on the proximal side of the fracture relative to the intramedullary device assembly). The relative movement of the compression member **16**, the bone engagement member **26**, the bone engagement member guide **24**, the intramedullary device **12**, and the distal segment **80** are shown in Fig. 6A with arrows on the respective elements.

Referring to Fig. 6B, after the desired amount of compression has been achieved, the intramedullary device **12** may be fastened to the proximal segment **84** to maintain compression of the distal and proximal segments **80**, **84**. For example, screws, pegs, bolts, pins or other fasteners **82** may be inserted into holes in the intramedullary device **12**, bicortically and/or unicortically, to fasten the proximal segment **84** to the intramedullary device **12**. In some embodiments, the holes in the distal and/or proximal portions of the intramedullary device **12** may have internal threads (or another type of capturing mechanism) that are configured to engage external threads (or a corresponding capturing mechanism) of the fasteners. Although Figs. 6A and 6B show the screws **82** in this example placed transversely to the device **12** and parallel to the other screws **82**, the screws **82** or other fasteners may have various orientations according to the configuration of the receiving holes in the intramedullary device **12** and other considerations to allow for proper fastening between the bone and the intramedullary device **12**.

In other embodiments, the proximal segment **84** may be provisionally fixed to the intramedullary assembly before compression is applied at the fracture such that compression at the fracture site may be provided without changing the position of the intramedullary device within the proximal segment. In this regard, the compression member may be pre-adjusted such that the bone engagement member is set at a pre-determined point along the guide adapter. Thus, as the intramedullary device is advanced into the medullary canal of the proximal bone segment **84**, the bone engagement member is pushed against the end of the bone and the intramedullary device is placed in the correct position in the proximal segment (i.e., the proximal end of the device is aligned flush with the cortex). The entire intramedullary guide assembly may then be pushed toward the distal segment **80**, while providing the ability for the surgeon to manually control and adjust the path of advancement of the proximal bone segment **84** towards the distal bone segment **80** by slight rotational or lateral movements of the intramedullary guide assembly until a desired level of initial compression is achieved at the fracture site. The position of the intramedullary device may be adjusted if necessary via the compression member. By pushing the two bone fragments together in this way, the intramedullary device assembly provisionally holds the fracture reduced until

the distal screws are in place. If more compression is required, the compression member may be advanced farther along the bone engagement member guide (towards the bone). Once the appropriate amount of compression is achieved, the proximal screws may be put in place.

5 In any case, the guide adapter, compression member, and other attached accessories (such as the drill guide) may not be needed once the desired amount of compression has been achieved and the intramedullary device **12** has been fastened to the distal and proximal segments **80**, **84** of the bone. As a result, the first end of the bone engagement member guide may be detached from the intramedullary device **12**, for
10 example by applying a second torque to the internally-threaded fastener **75** that causes the breakaway stud **66** to break free of the intramedullary device **12**. In this way, the intramedullary device **12** may remain in the medullar canal of the bone, with the bone segments **80**, **84** attached to facilitate stabilization of the defect and proper healing, and, at the same time, extraneous components of the assembly may be removed to provide a
15 relatively unobstructed surface of the bone and allow the patient to use the affected part to the extent possible with greater comfort.

In embodiments that include a breakaway stud (Figs. 8, 9A and 9B), the guide adapter **14** and the compression member **16** may be detached from the inserted and fastened intramedullary device **12** by applying a second torque to the internally-threaded
20 fastener **75** which breaks free the breakaway stud **66** (for example, at the region of concentrated stress **72**). Alternatively, the guide adapter **14** and compression member **16** may be detached from the inserted and fastened intramedullary device **12** by unthreading the internally-threaded fastener **75** from the breakaway stud **66** and disengaging the breakaway stud **66** from the guide adapter **14**. The breakaway stud **66** may then be
25 removed from the intramedullary device **12** by bending and breaking free (for example, at the region of concentrated stress **72**), cutting, or using a second internally-threaded fastener that could be threaded on to the breakaway stud **66** and seat on the nub **13** or the proximal end of the intramedullary device **12** and pull the breakaway stud **66** free from the intramedullary device **12**. Furthermore, if removal of the intramedullary device **12** from
30 the bone is required at some later time, the lip **15** may be used to withdraw the intramedullary device **12** from the medullar canal, as previously discussed.

It should be appreciated that while the above described embodiments feature an external thread on the breakaway stud and an internal thread on the fastener of the guide adapter, other embodiments may have an internal thread on the breakaway stud and an
35 external thread on the fastener retained within the guide adapter.

Many modifications and other embodiments of the inventions set forth herein will come to mind to one skilled in the art to which these inventions pertain having the benefit

of the teachings presented in the foregoing descriptions and the associated drawings. Therefore, it is to be understood that the inventions are not to be limited to the specific embodiments disclosed and that modifications and other embodiments are intended to be included within the scope of the appended claims. Although specific terms are employed
5 herein, they are used in a generic and descriptive sense only and not for purposes of limitation.

THAT WHICH IS CLAIMED:

1. An intramedullary device for repairing a defect of a bone, comprising:
an elongate body including a proximal end and a distal end; and
5 a stud protruding from the proximal end of the elongate body configured to be removably attached to a guide adapter, the stud comprising;
a distal portion attached to the proximal end of the elongate body; and
a proximal portion opposite the distal portion;
wherein at least the proximal portion of the stud comprises a threaded
10 portion;
wherein the distal portion defines a first cross sectional area and a second cross-sectional area wherein the second cross-sectional area is smaller than the first cross-sectional area and wherein the stud is broken at the second cross-sectional area when a threshold amount of force is applied to the threaded
15 portion.
2. The intramedullary device of Claim 1, wherein the distal portion of the stud is tapered from the first cross-sectional area proximate the proximal portion of the stud to the second cross-sectional area proximate the proximal end of the elongate body.
20
3. The intramedullary device of Claim 1 further comprising a medial portion of the stud disposed between the distal portion and the proximal portion, wherein the medial portion of the stud comprises at least one flat facet.
- 25 4. The intramedullary device of Claim 1, wherein the distal portion of the stud is tapered.
5. The intramedullary device of Claim 1, further comprising a nub between the stud and the proximal portion of the elongate body.
30
6. The intramedullary device of Claim 1, wherein the threads of the breakaway stud of the intramedullary device are configured to engage a threaded fastener within a guide adapter.
- 35 7. The intramedullary device of Claim 6, wherein the intramedullary device is configured to be secured to the guide adapter by applying a first torque to the threaded fastener.

8. The intramedullary device of claim 7, wherein the intramedullary device is configured to be separated from the guide adapter when the breakaway stud is broken away from the intramedullary device by a second torque applied to the threaded fastener
5 wherein the second torque is greater than the first torque.
9. The intramedullary device of claim 8, wherein the threaded fastener comprises a fastener head that engages a shoulder within the guide adapter to retain the threaded fastener within the guide adapter.
10
10. The intramedullary device of claim 6, further comprising a recess configured to engage a tab defined by the guide adapter to prevent relative rotation between the intramedullary device and the guide adapter.
- 15 11. The intramedullary device of claim 1, further comprising an undercut proximate the second cross sectional area.
12. A method of repairing a bone defect using an intramedullary device assembly including an intramedullary device with a threaded breakaway stud extending therefrom
20 and a guide adapter, the method comprising:
inserting the breakaway stud of the intramedullary device into the guide adapter;
securing the intramedullary device within the guide adapter by applying a first torque to a threaded fastener within the guide adapter to engage the threads of the breakaway stud of the intramedullary device;
25 inserting the intramedullary device into a medullary canal of the bone;
securing the intramedullary device within the medullary canal of the bone; and
applying a second torque to the threaded fastener within the guide adapter
wherein the second torque is greater than the first torque and wherein the second torque causes the breakaway stud to break free of the intramedullary device.
30
13. The method of Claim 12, wherein the first torque is applied using a torque-limiting driver.
14. The method of Claim 12, wherein the second torque is applied using a standard,
35 non-torque-limiting driver.

15. The method of Claim 12, wherein the first torque and the second torque are applied using an adjustable torque driver.

5 16. The method of Claim 12, wherein the first torque is applied using a first adjustable torque driver and wherein the second torque is applied using a second adjustable torque driver.

17. The method of Claim 12, wherein the step of securing the intramedullary device within the medullary canal of the bone further comprises the steps of:

10 securing the intramedullary device to a distal segment of the bone located on a distal side of the defect;

 applying compression with a compression member attached to the guide adapter before securing the intramedullary device to the proximal segment of the bone

15 securing the intramedullary device to the proximal segment of the bone to maintain the positions of the distal and proximal segments of the bone.

18. The method of Claim 12, further comprising the step of removing the breakaway stud from the guide adapter after the guide adapter has been detached from the intramedullary device.

20

19. The method of Claim 18, further comprising the step of securing a different intramedullary device within the guide adapter.

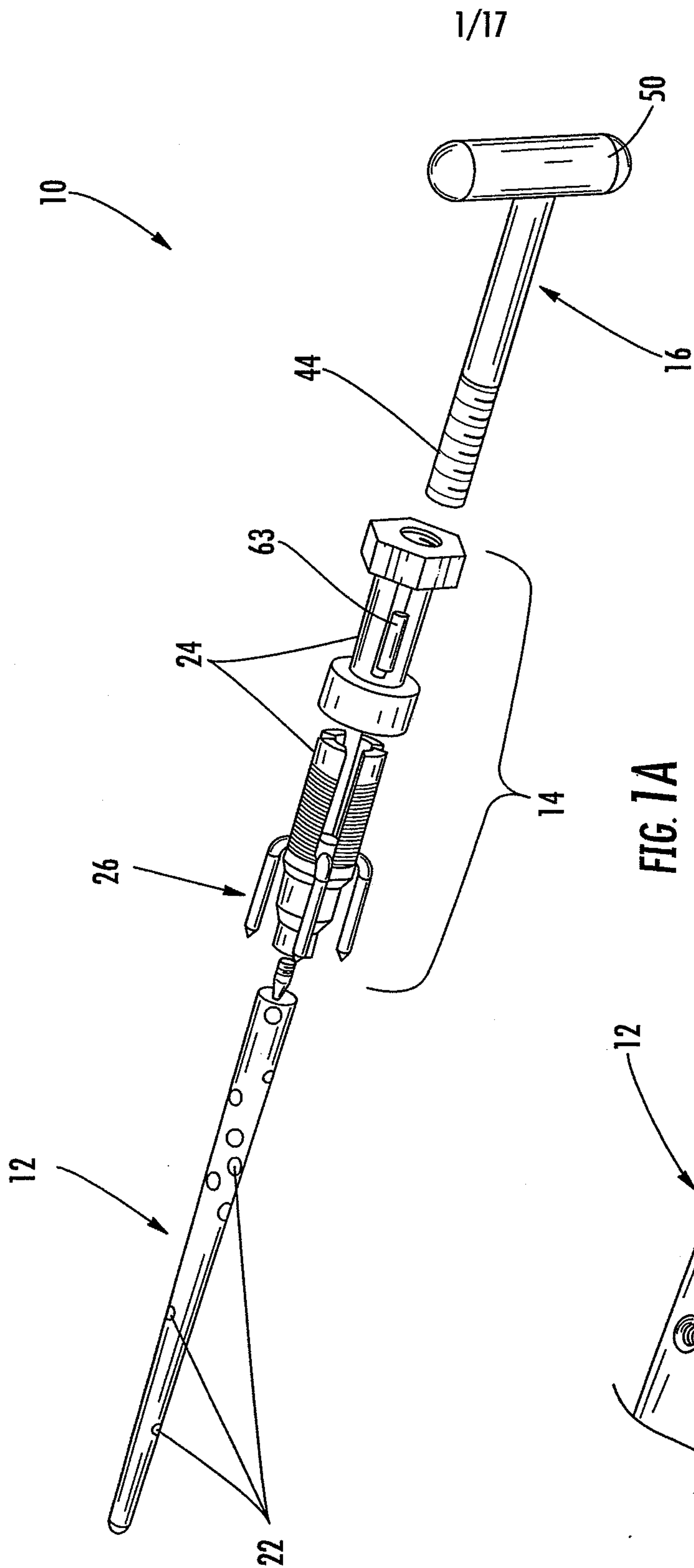

2/17

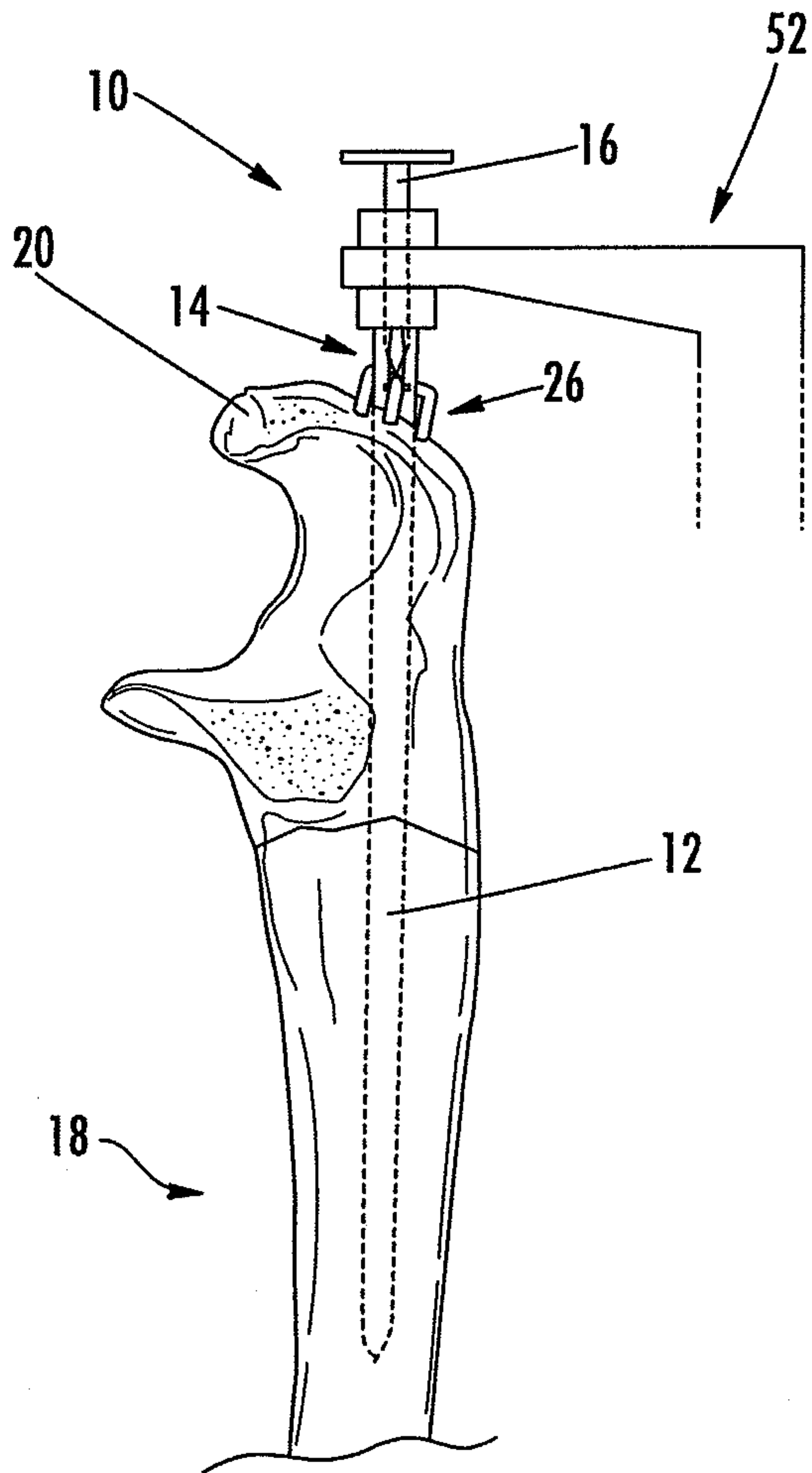

FIG. 2A

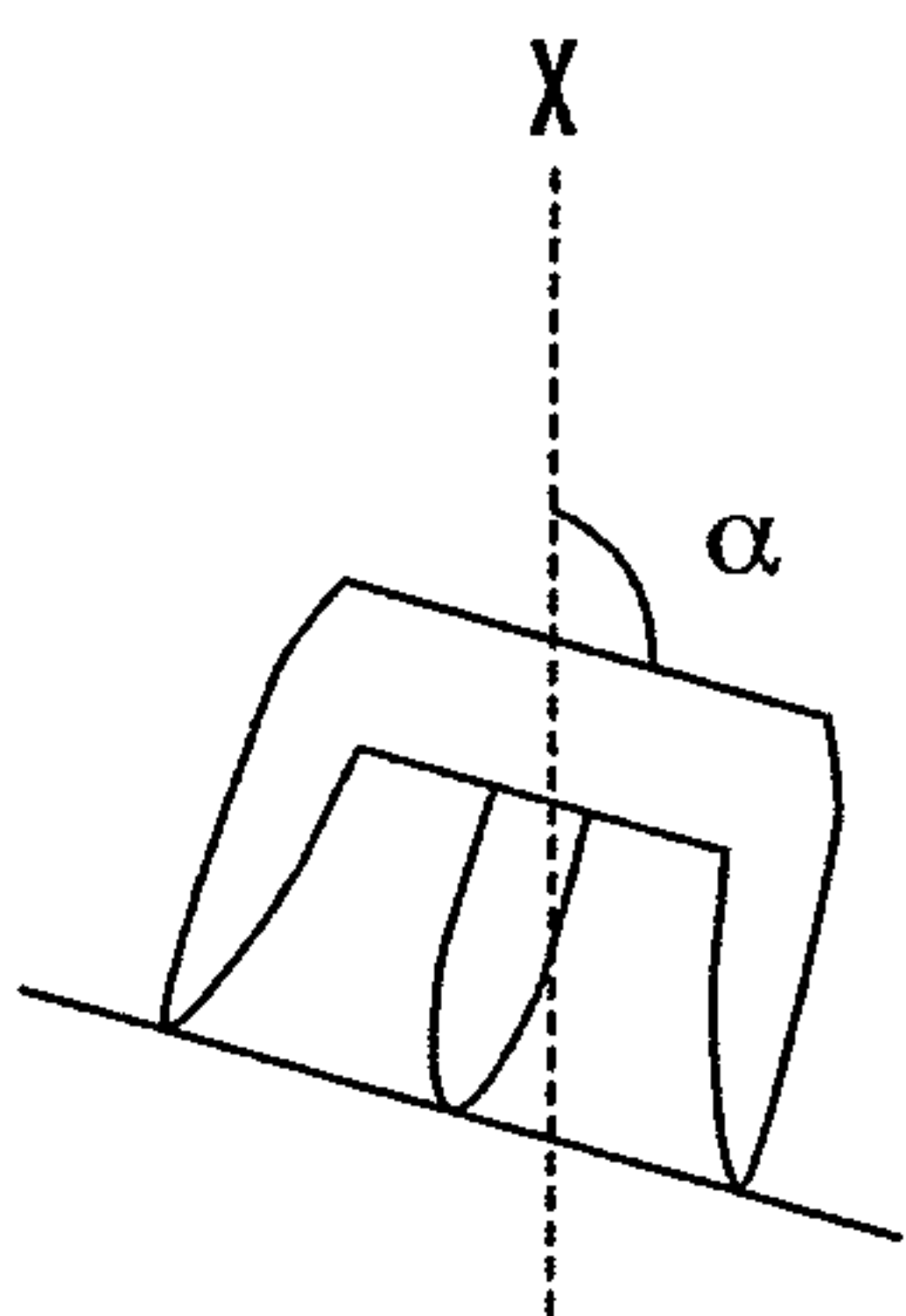

FIG. 2B

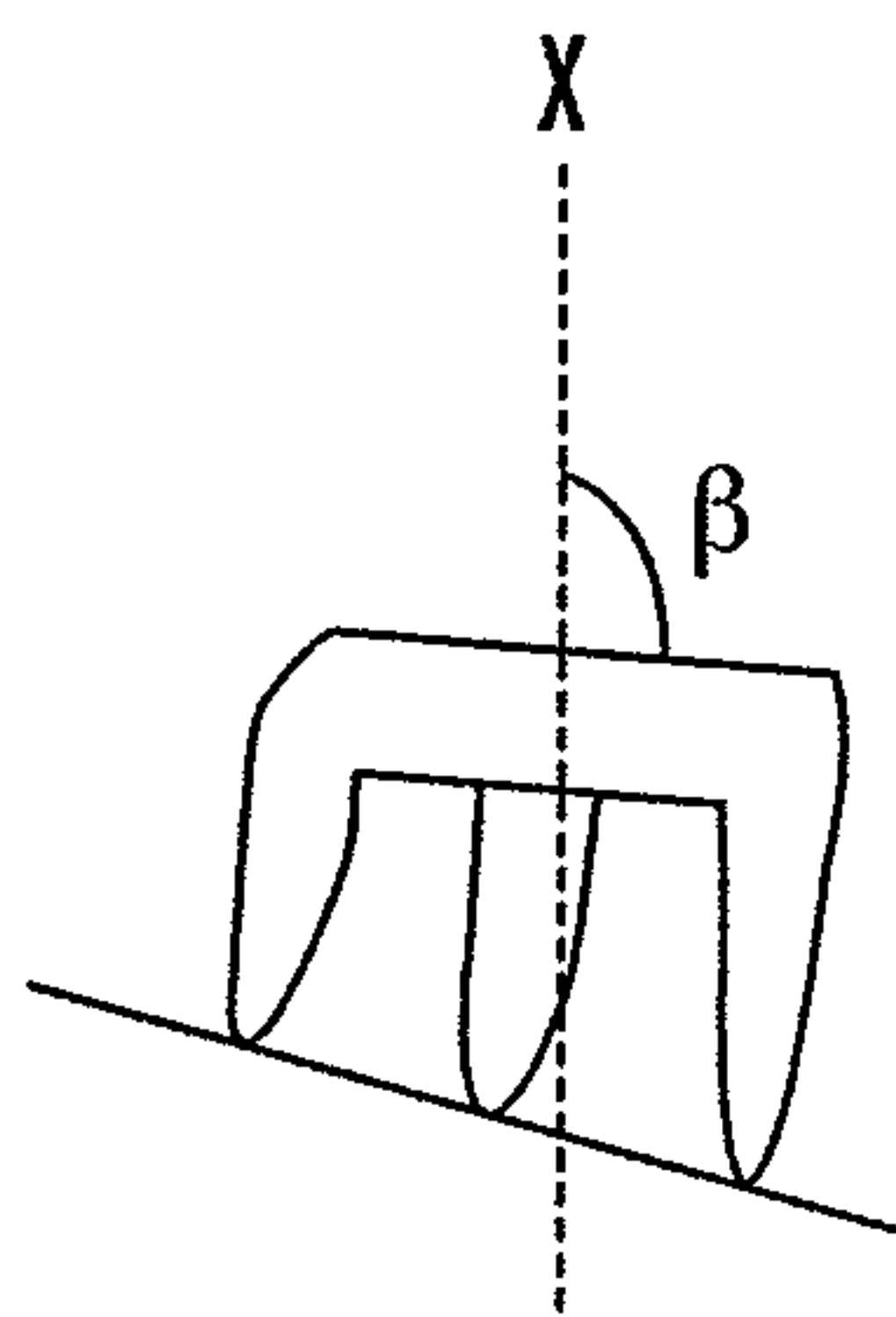

FIG. 2C

3/17

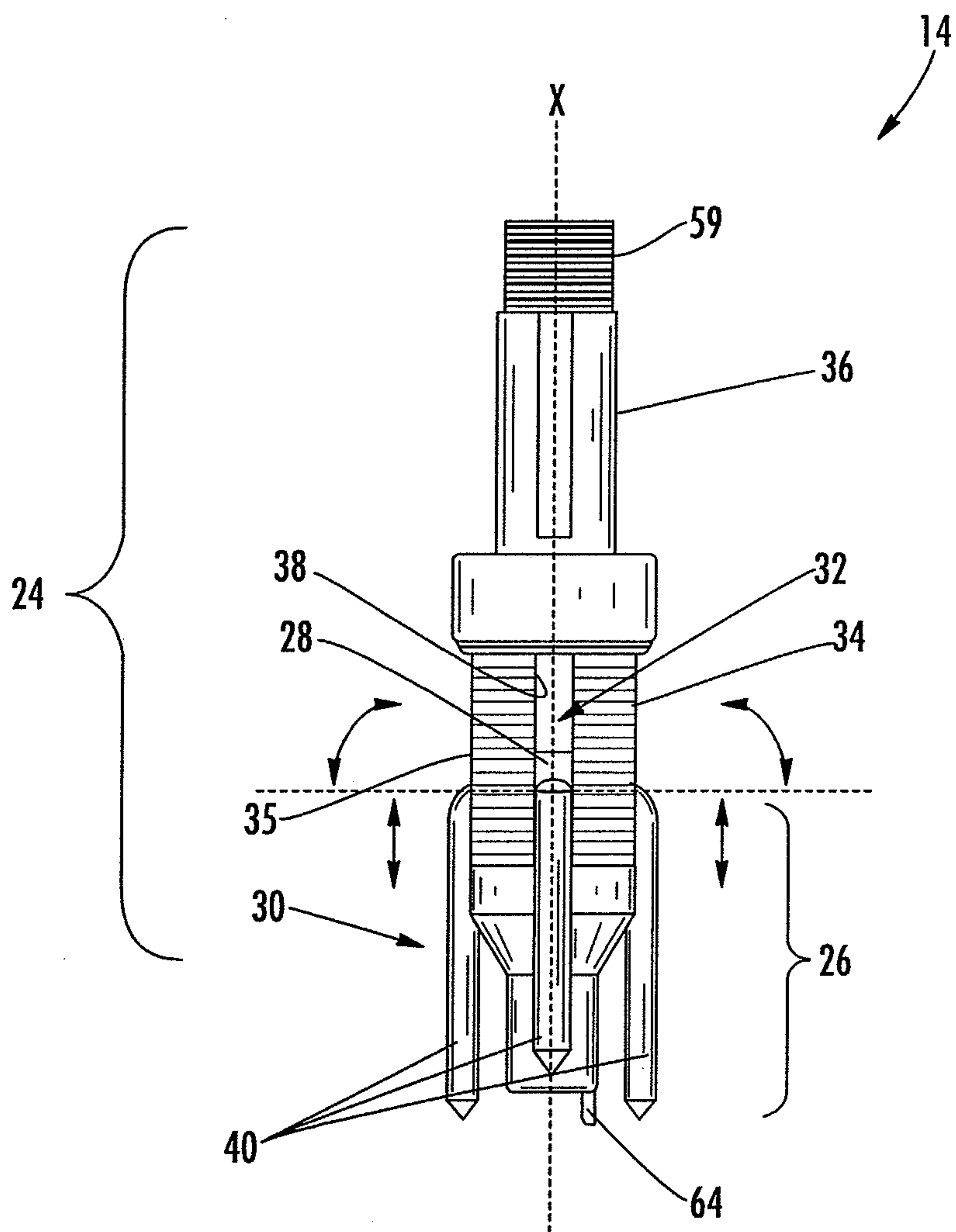

FIG. 3

4/17

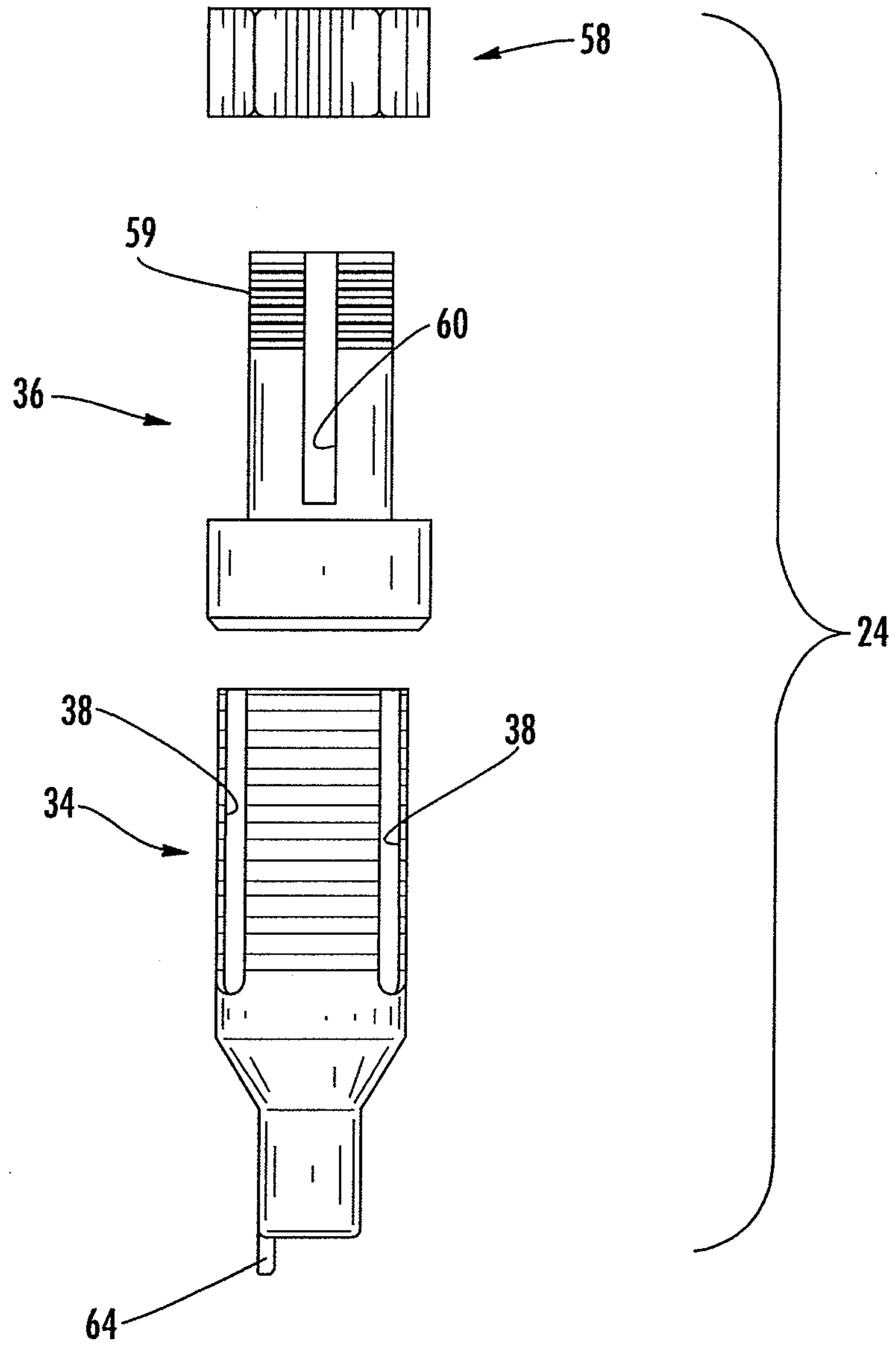

FIG. 4

5/17

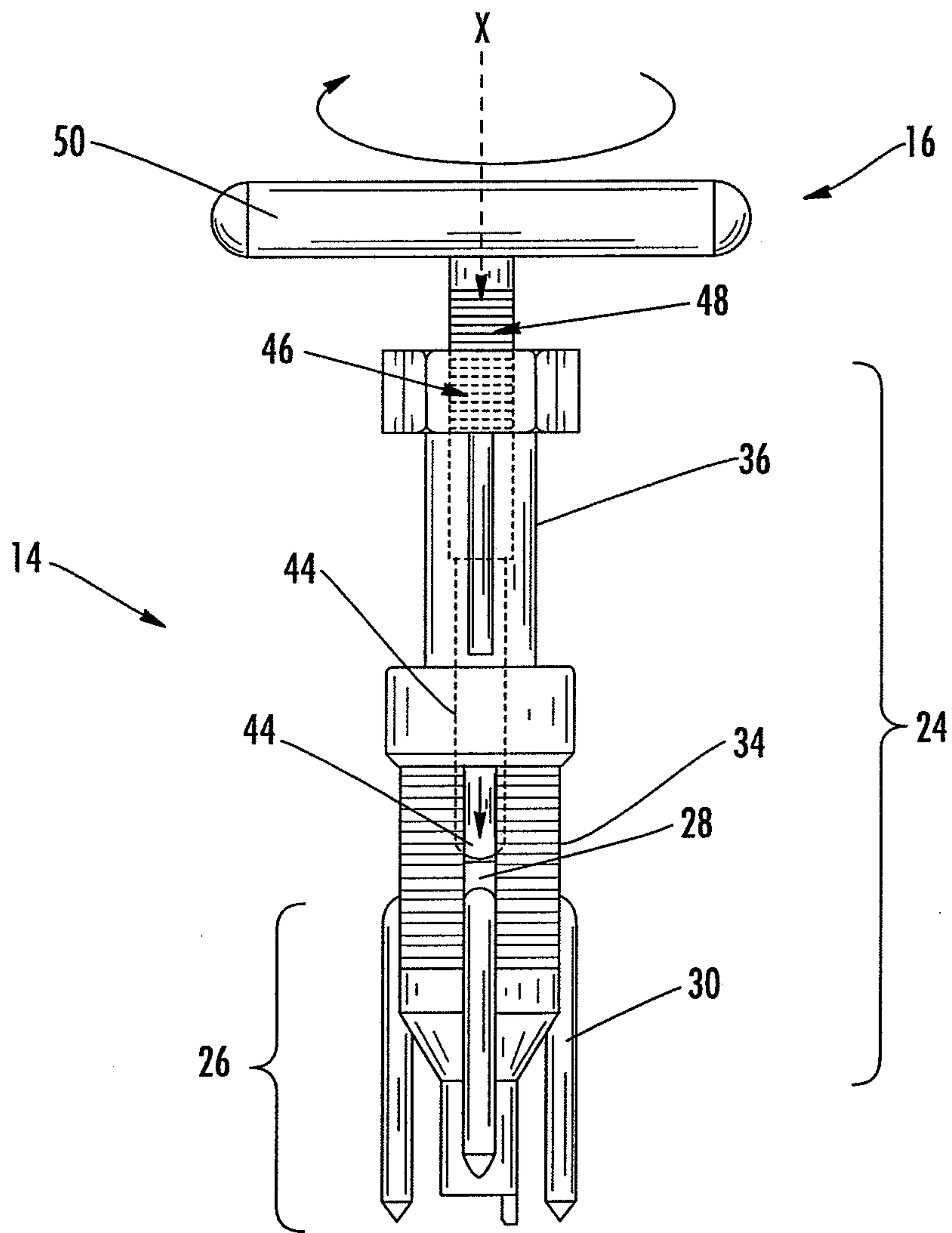

FIG. 5A

6/17

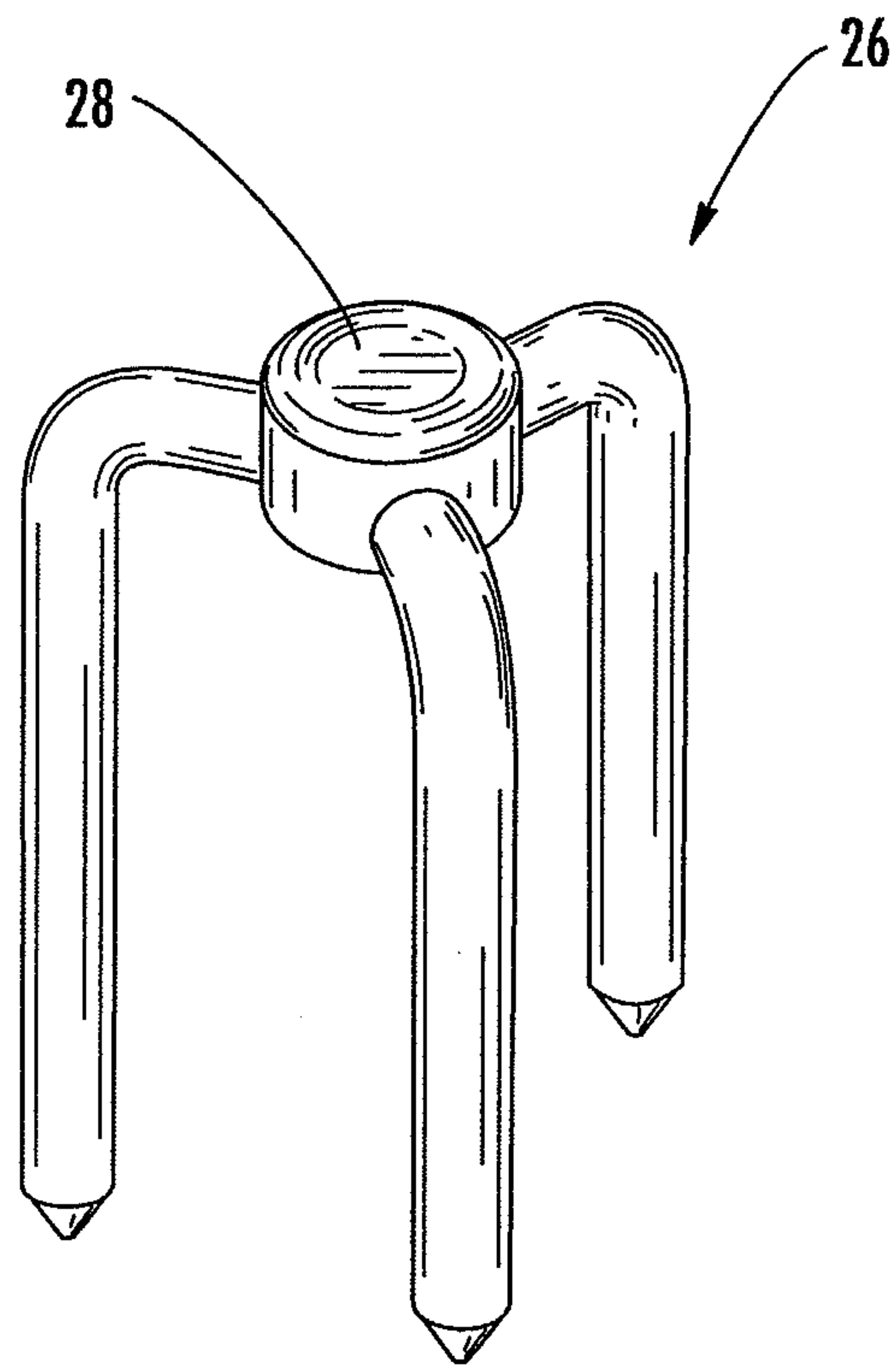

FIG. 5B

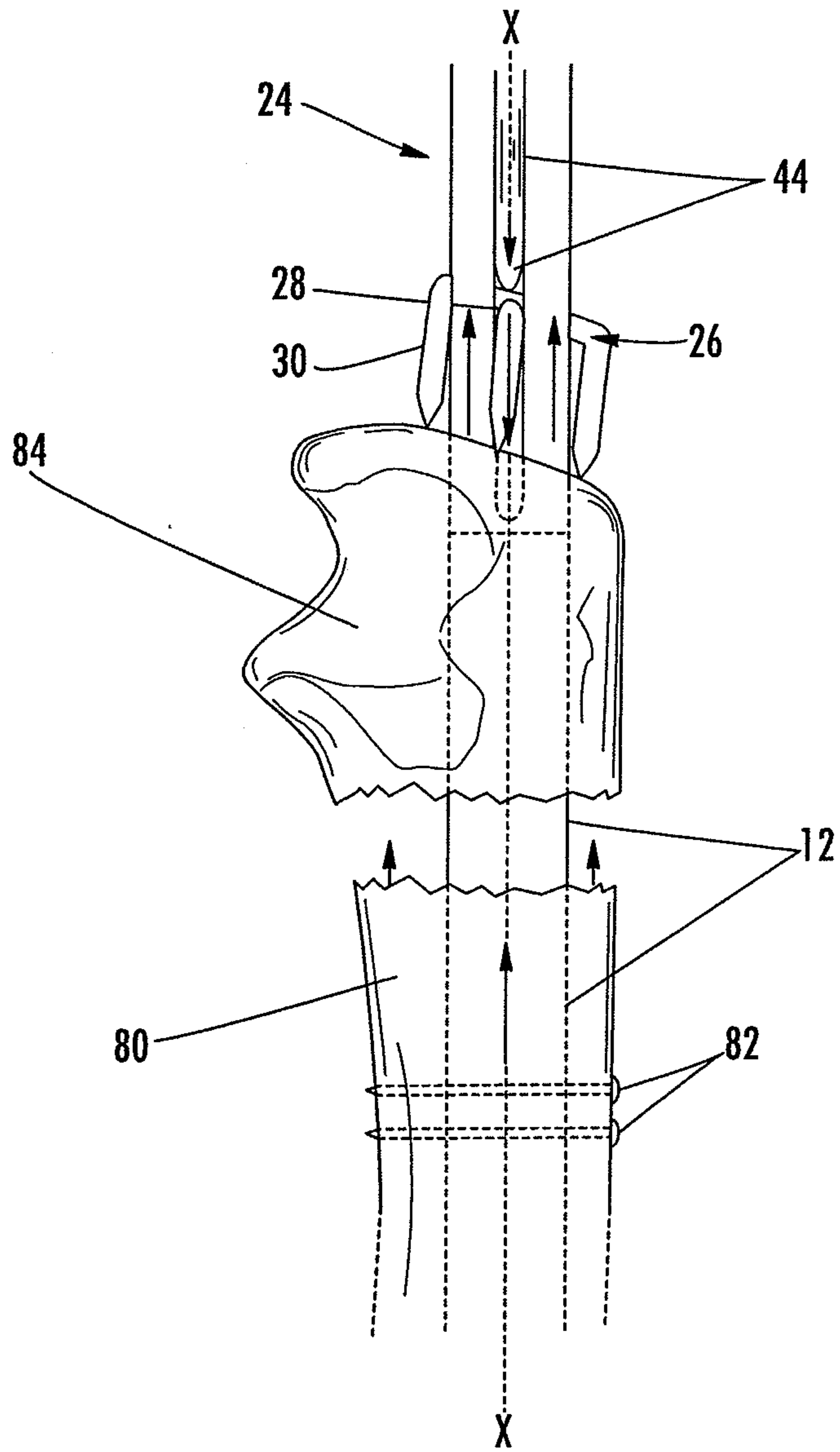

FIG. 6A

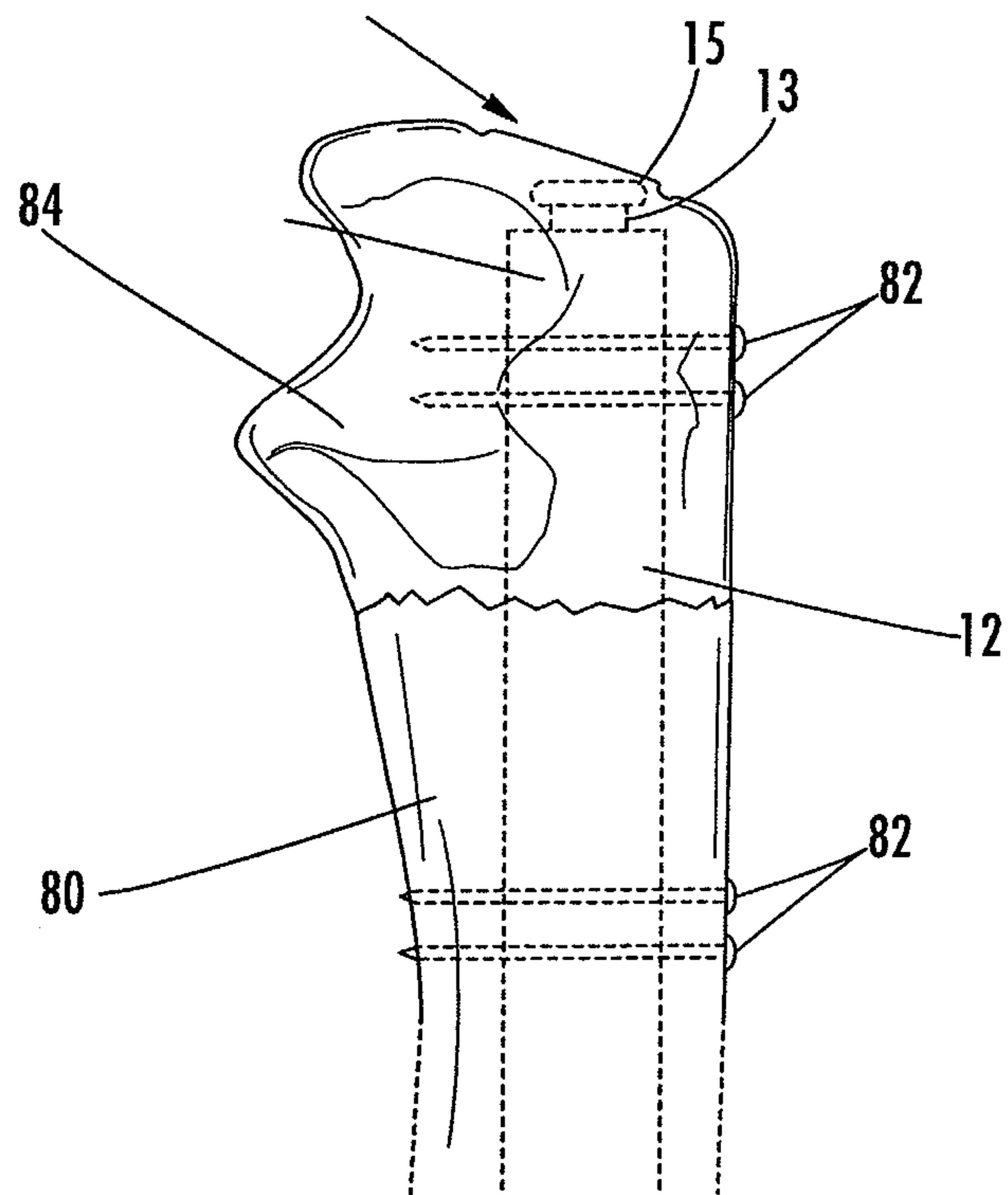
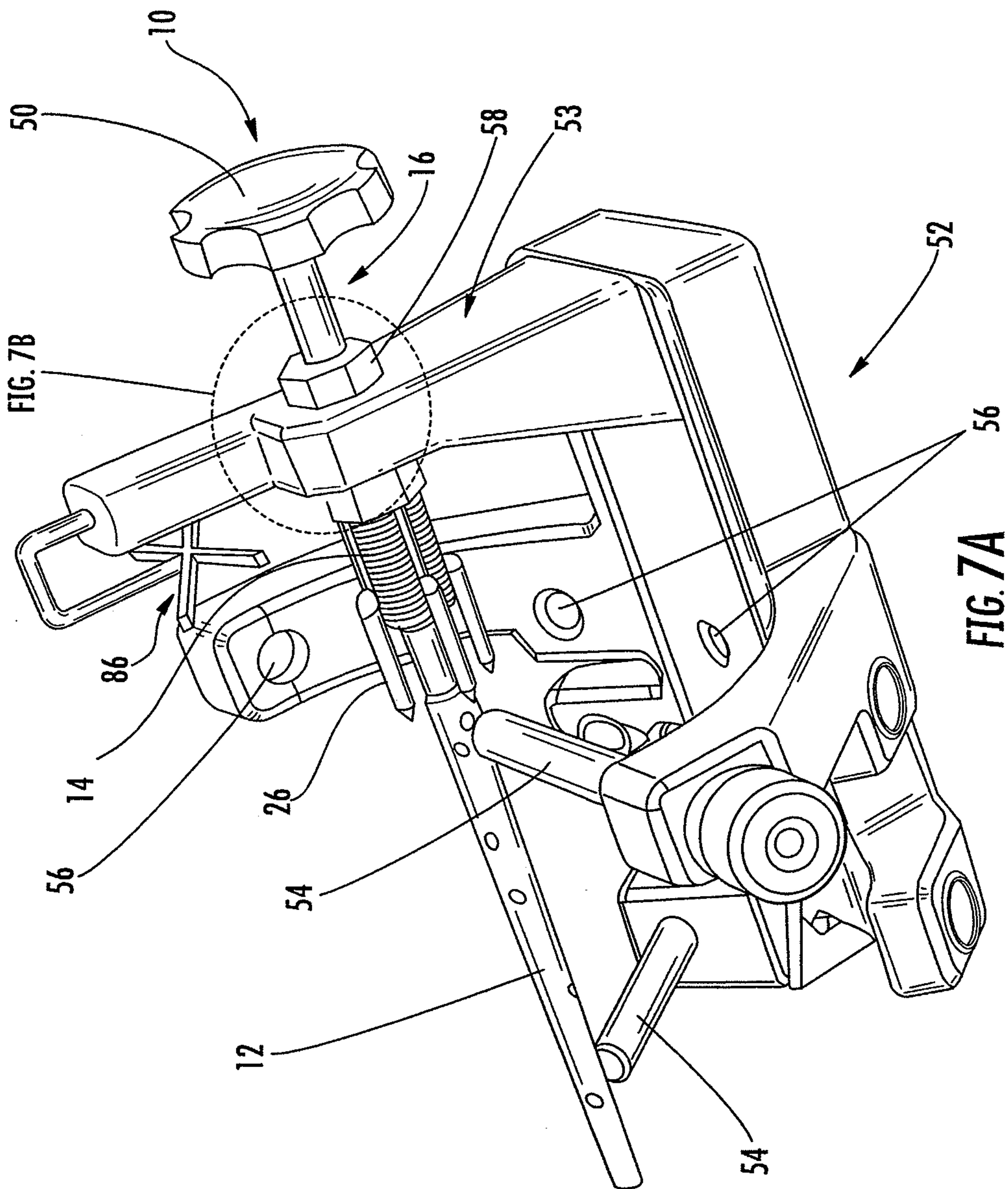

FIG. 6B



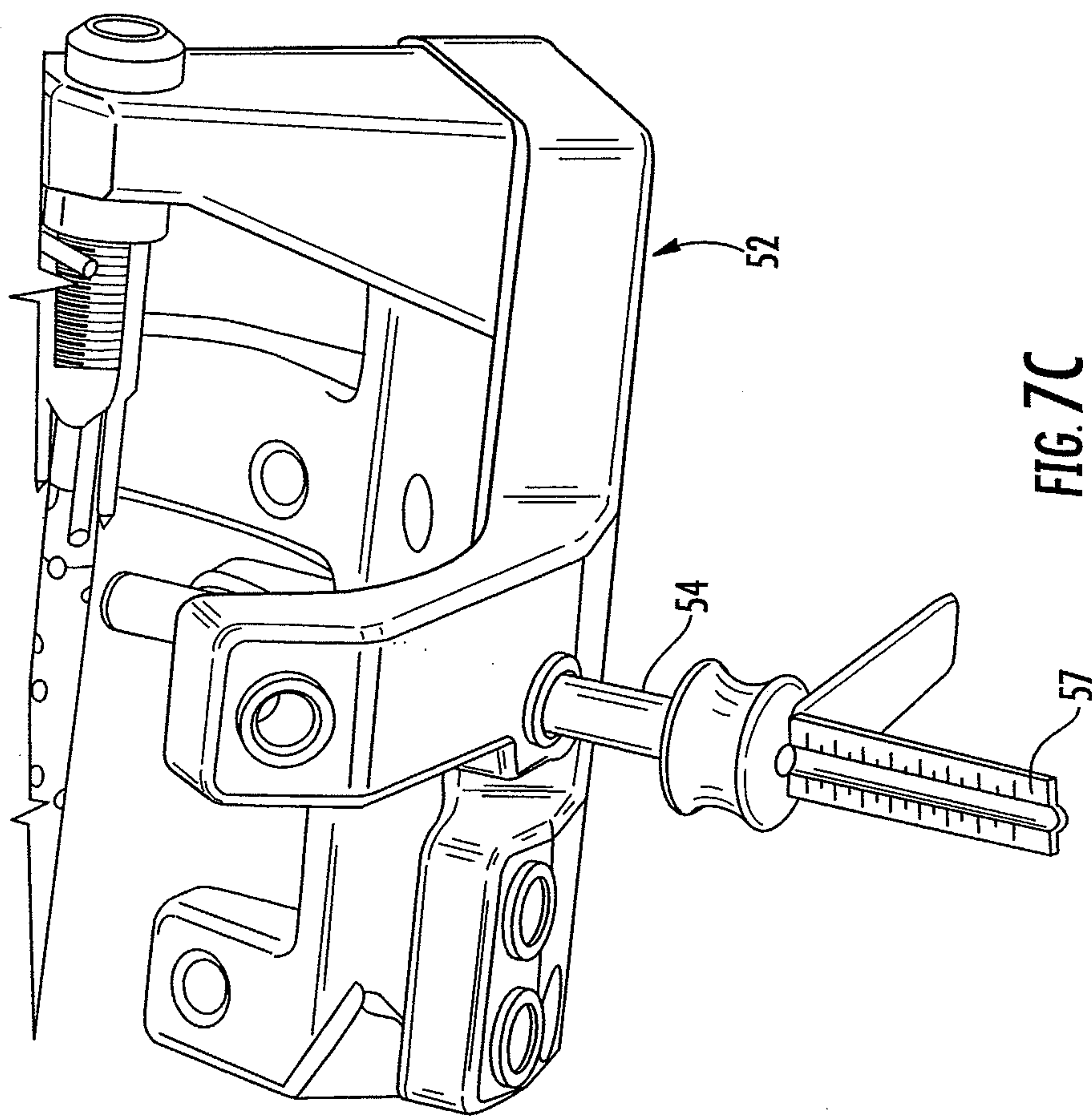

FIG. 7C

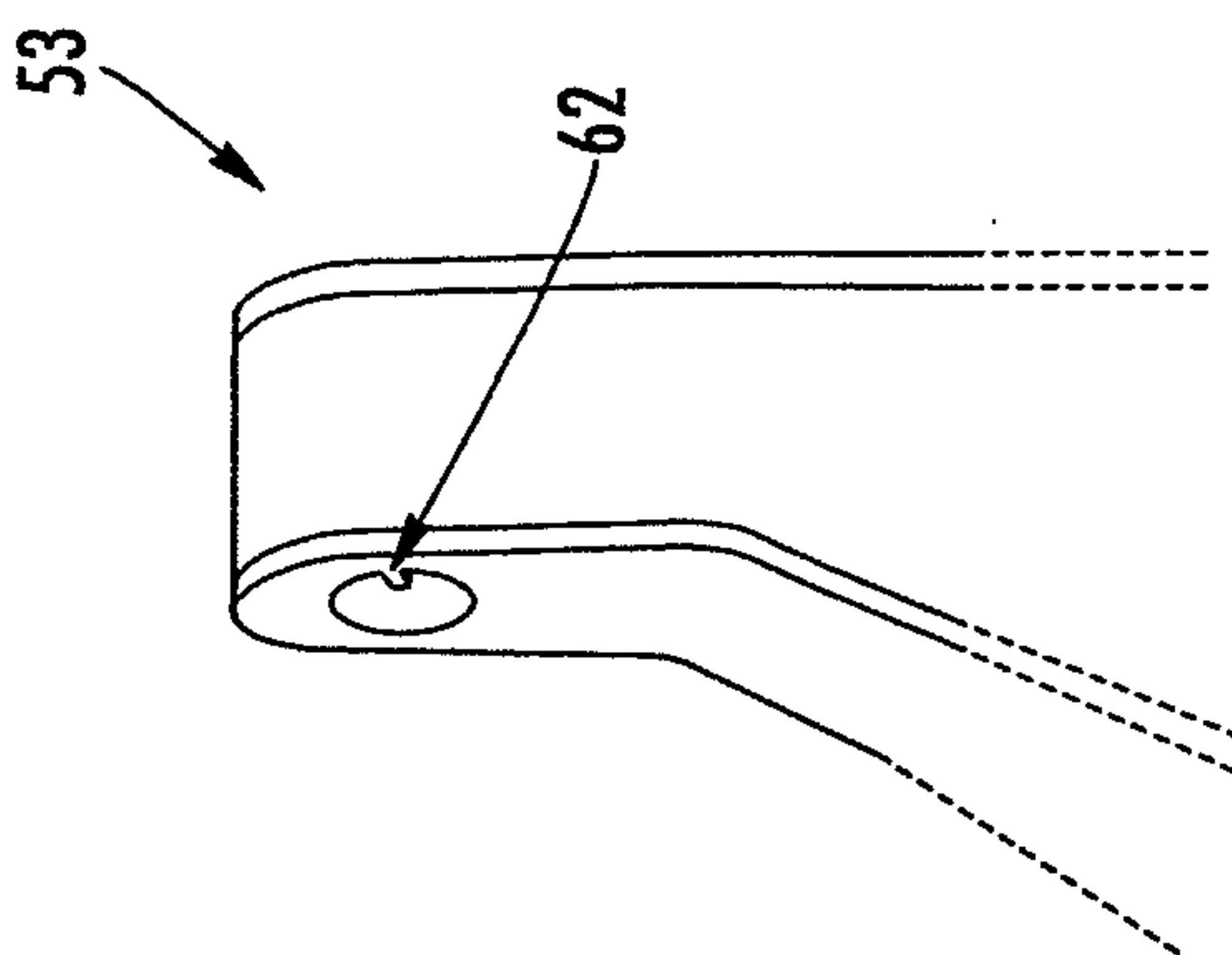

FIG. 7B

11/17

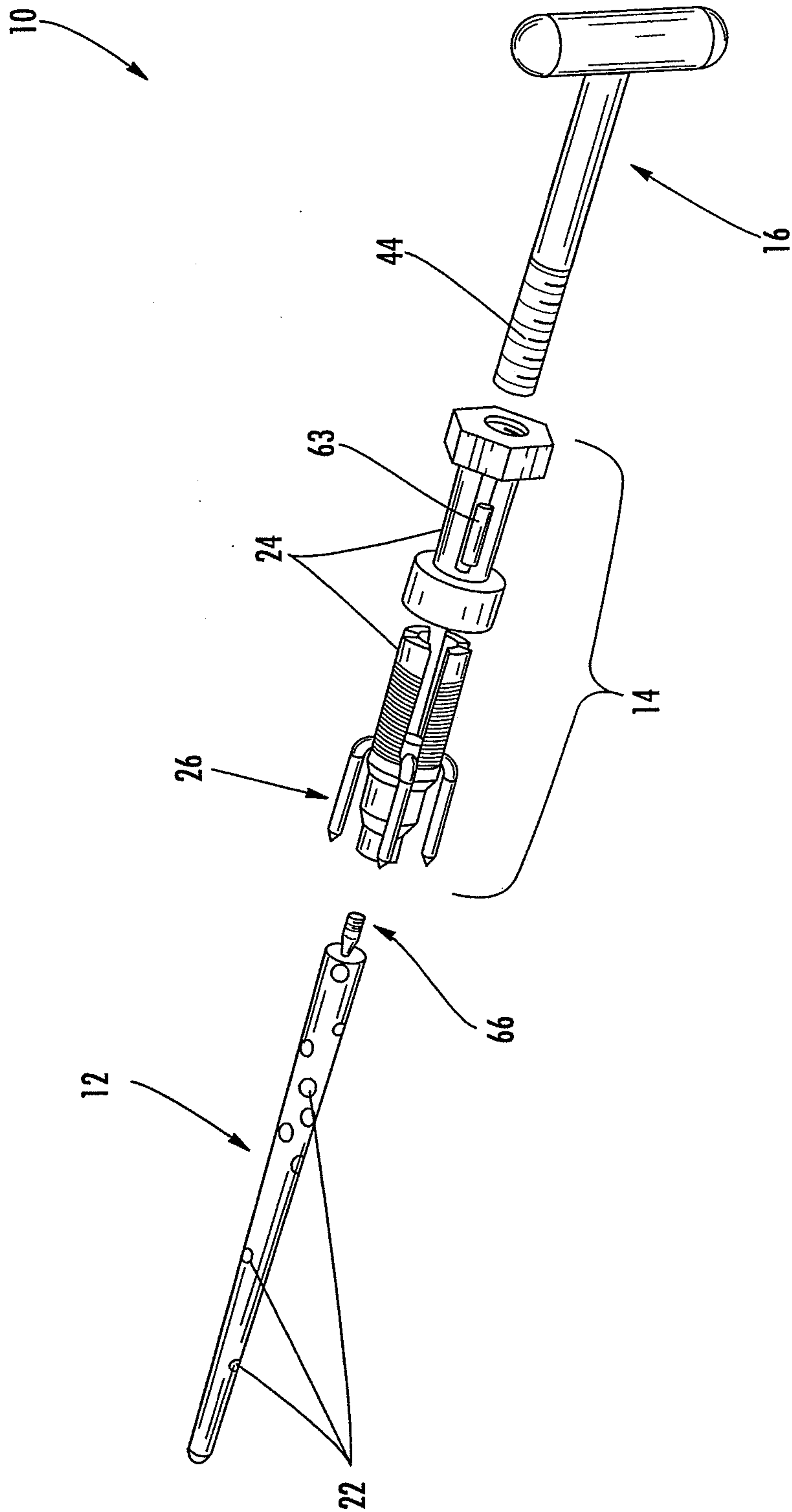
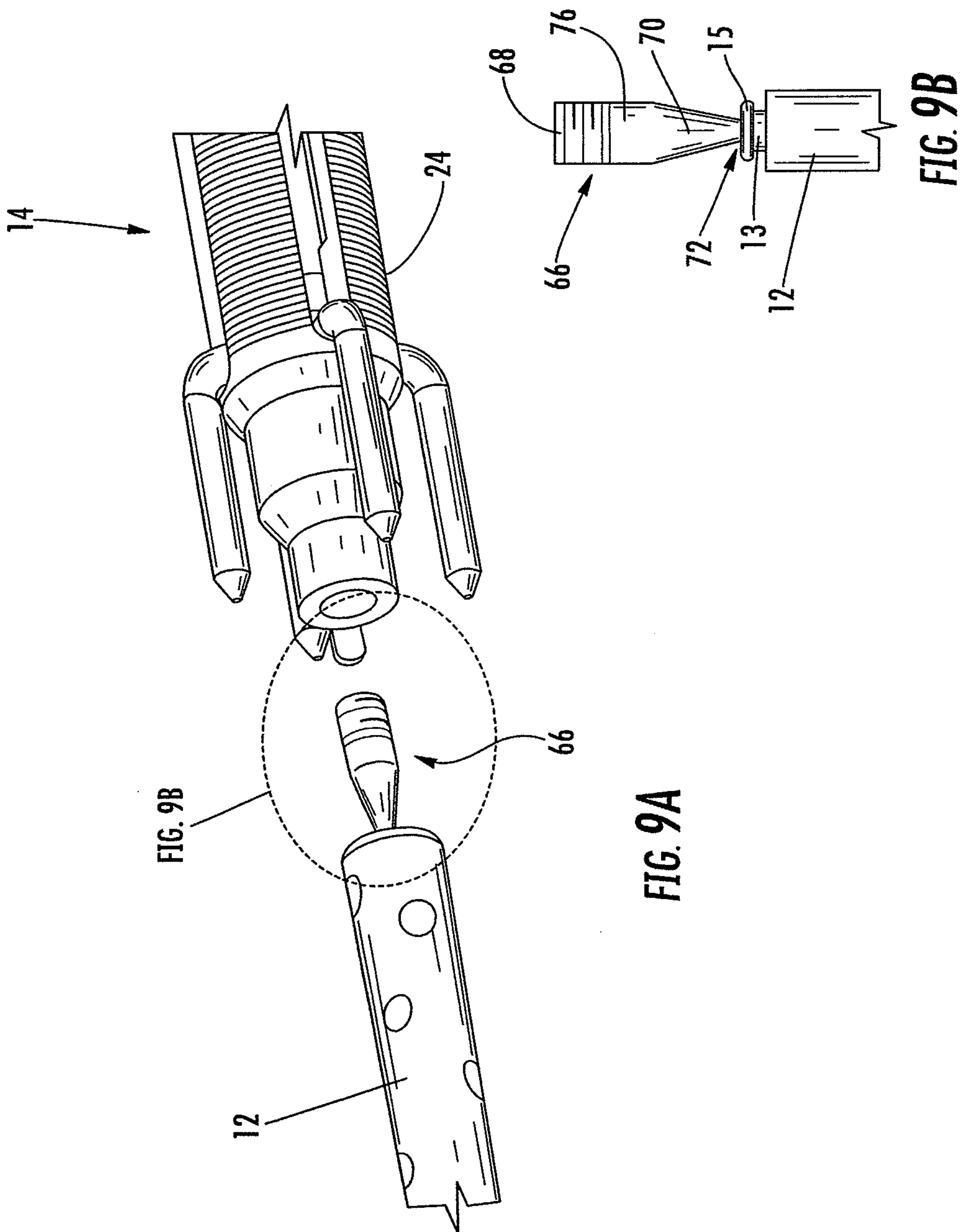

FIG. 8



13/17

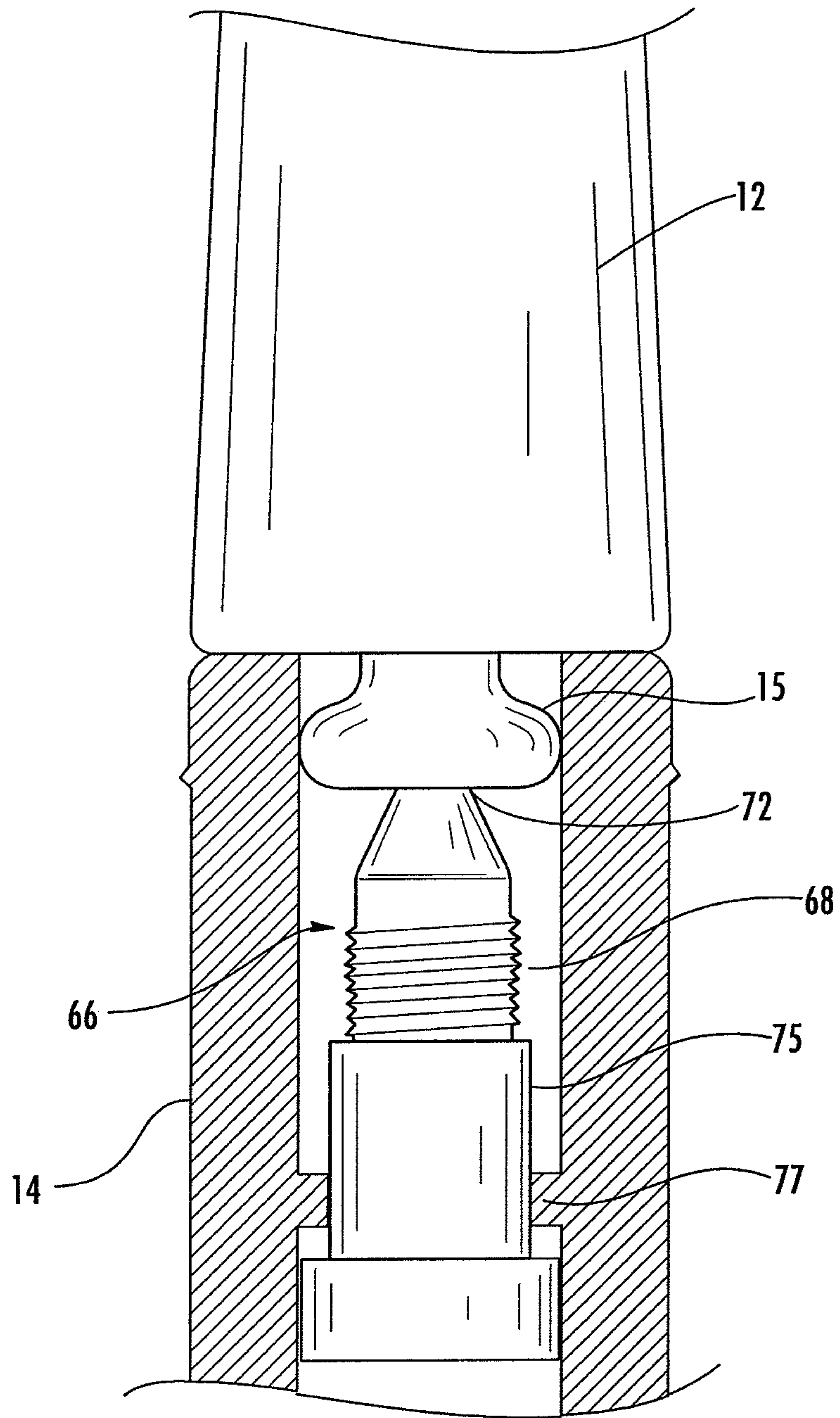

FIG. 9C

14/17

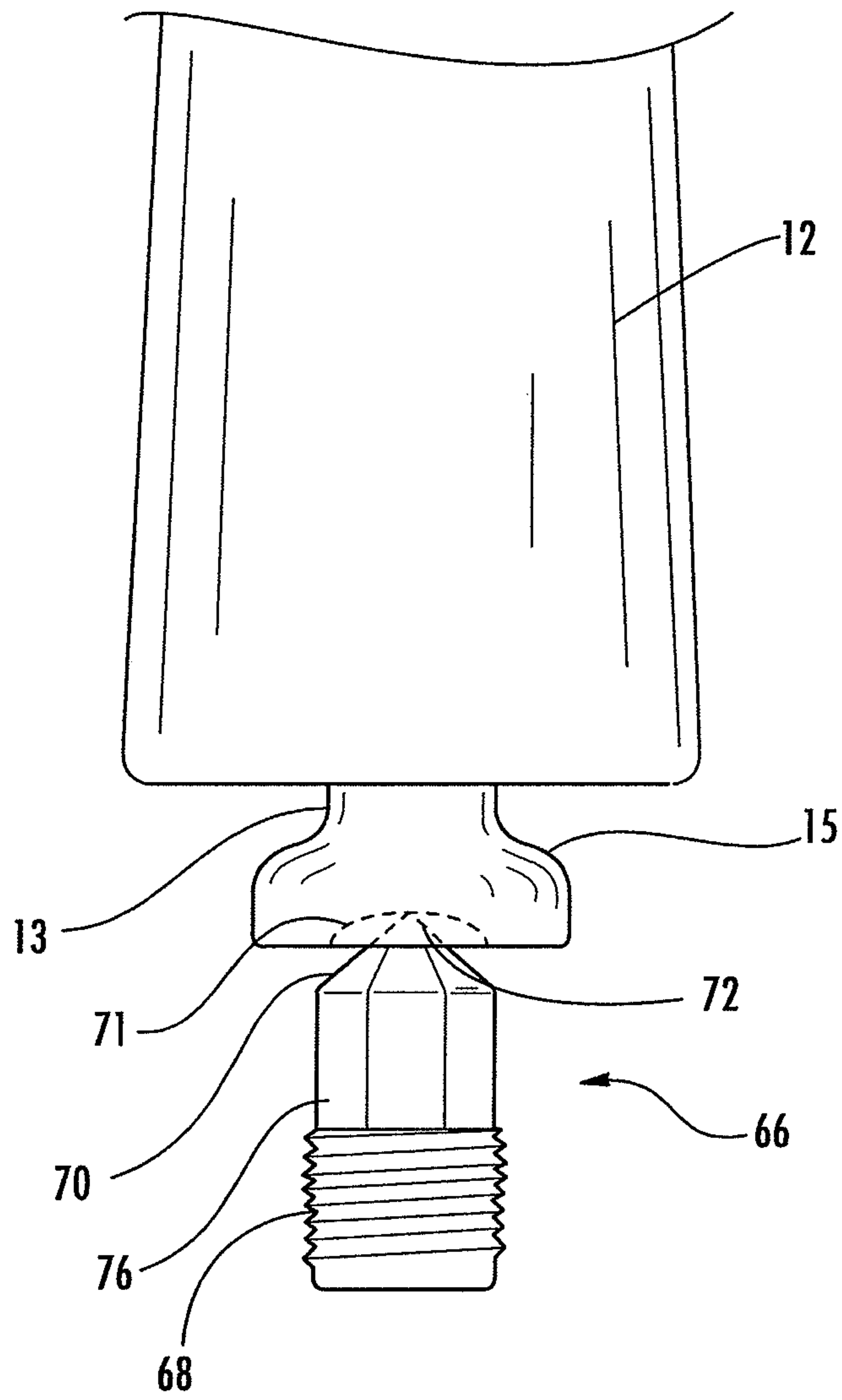

FIG. 9D

15/17

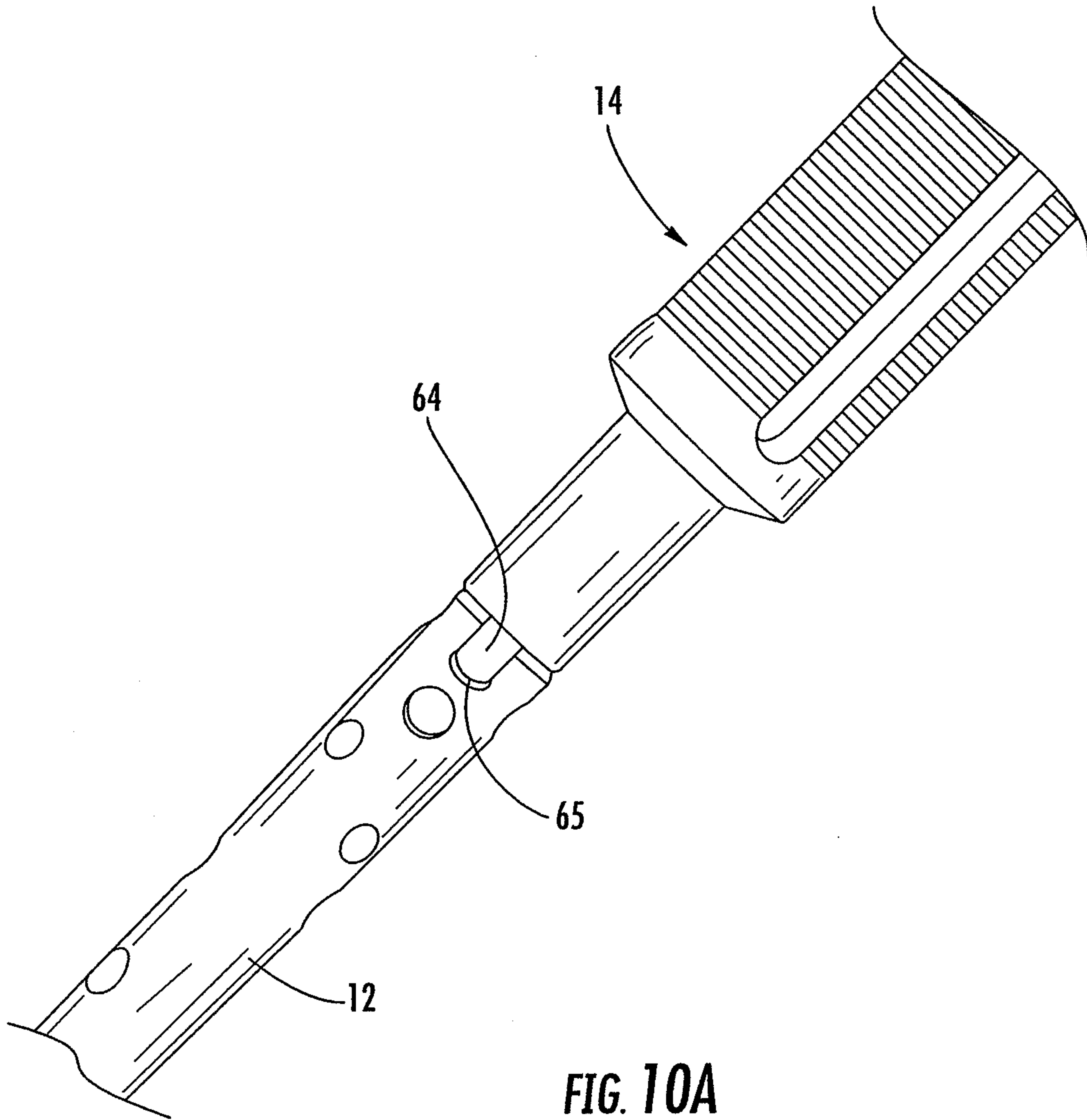

FIG. 10A

16/17

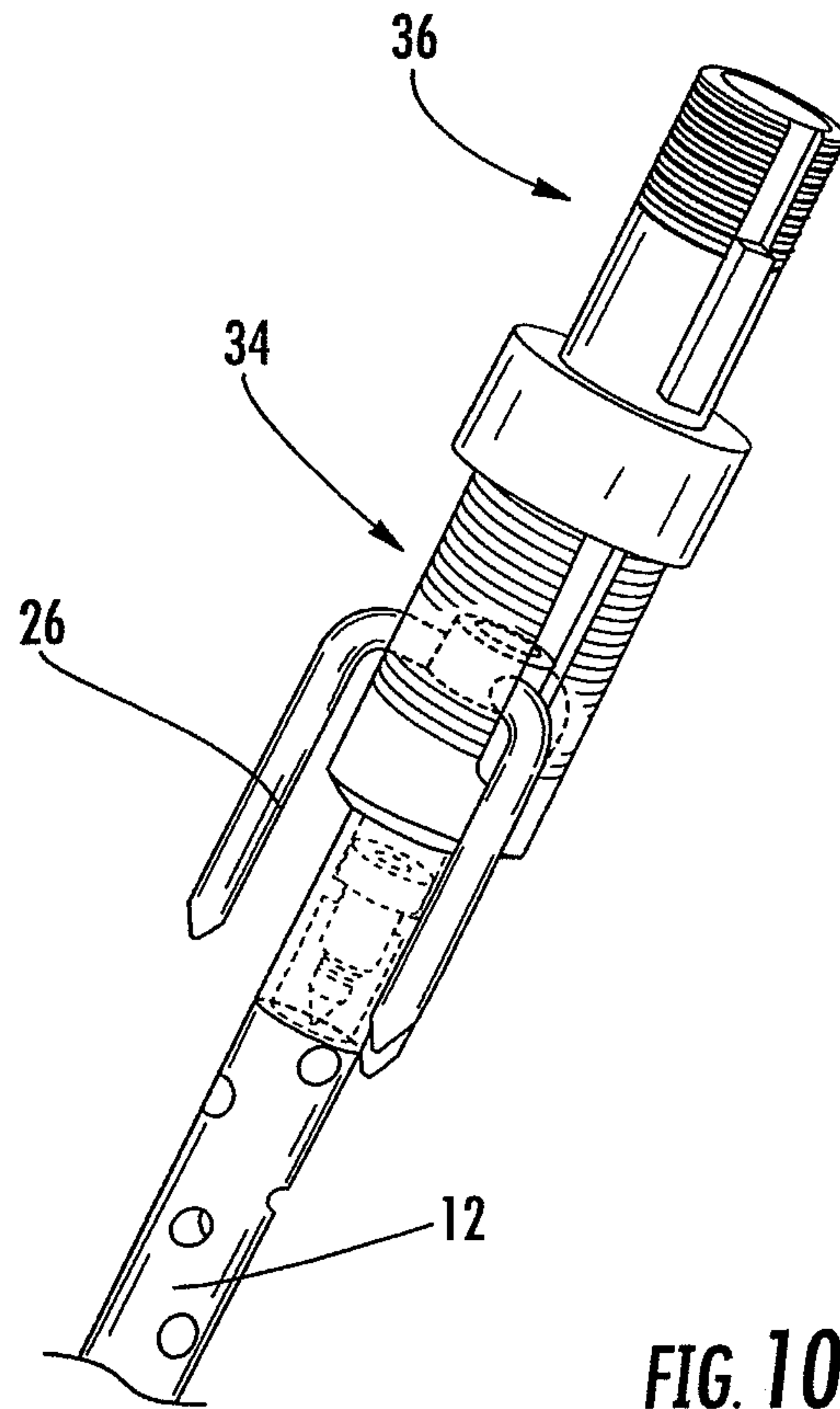

FIG. 10B

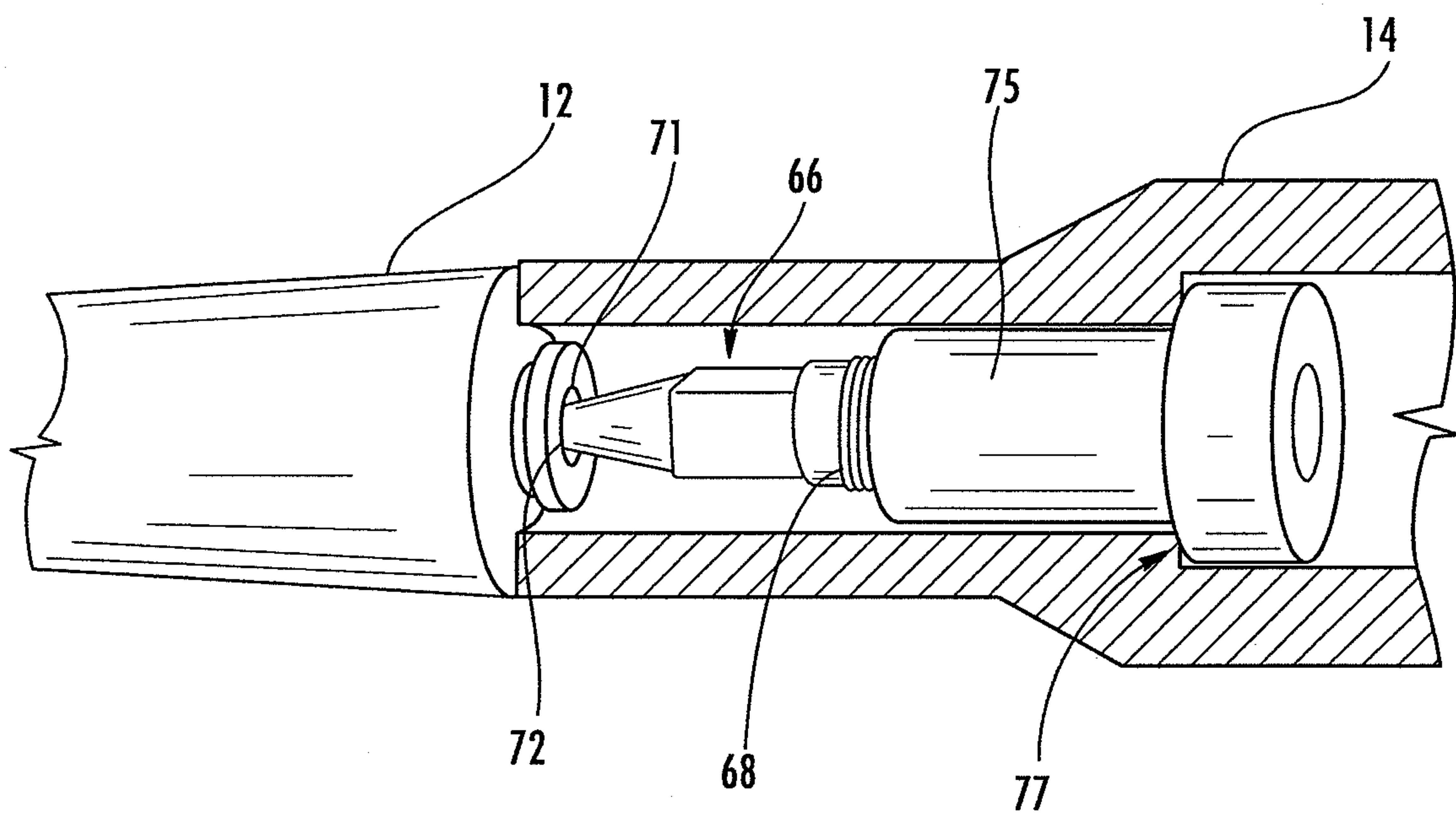

FIG. 10C

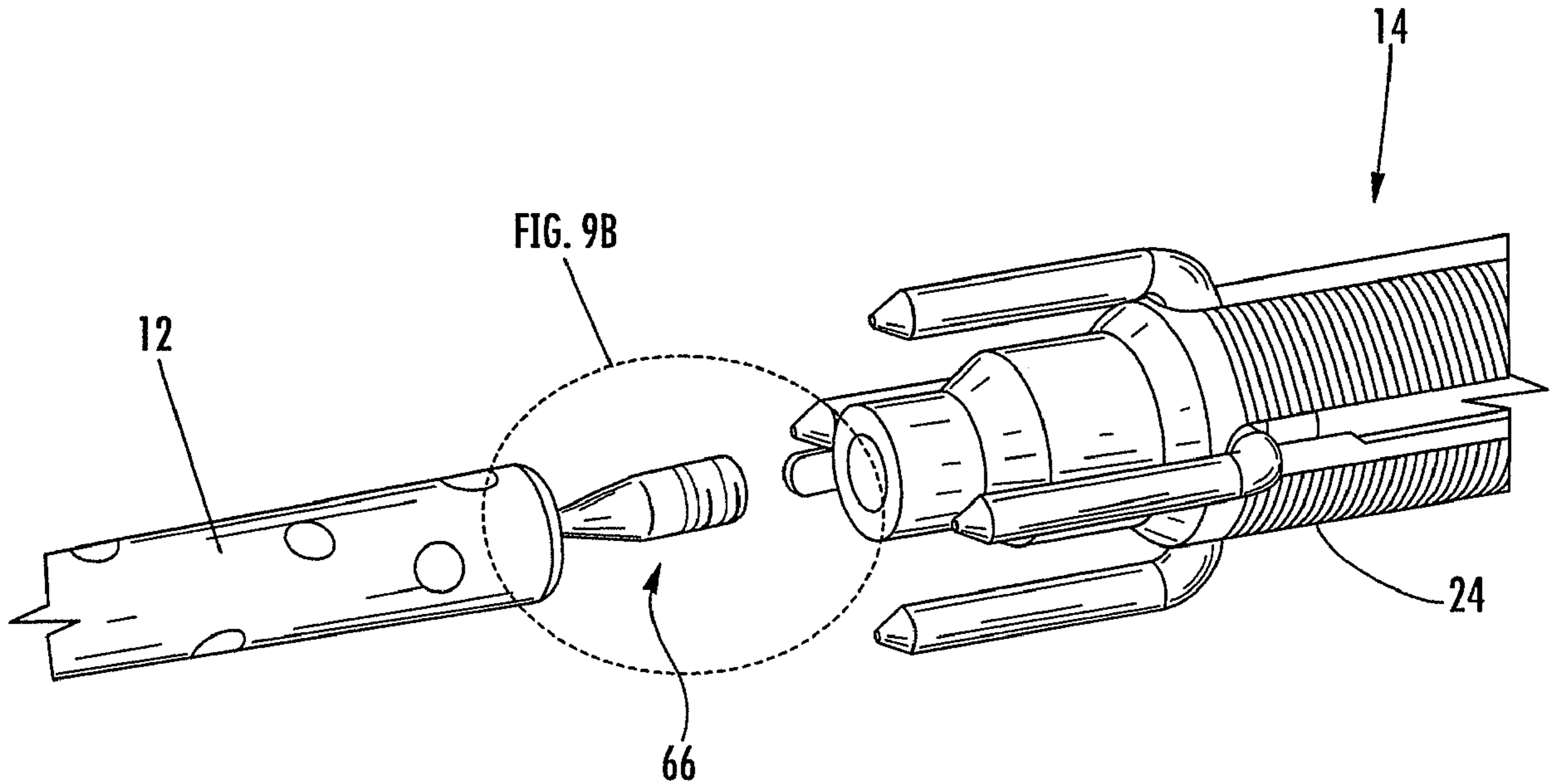

FIG. 9A