

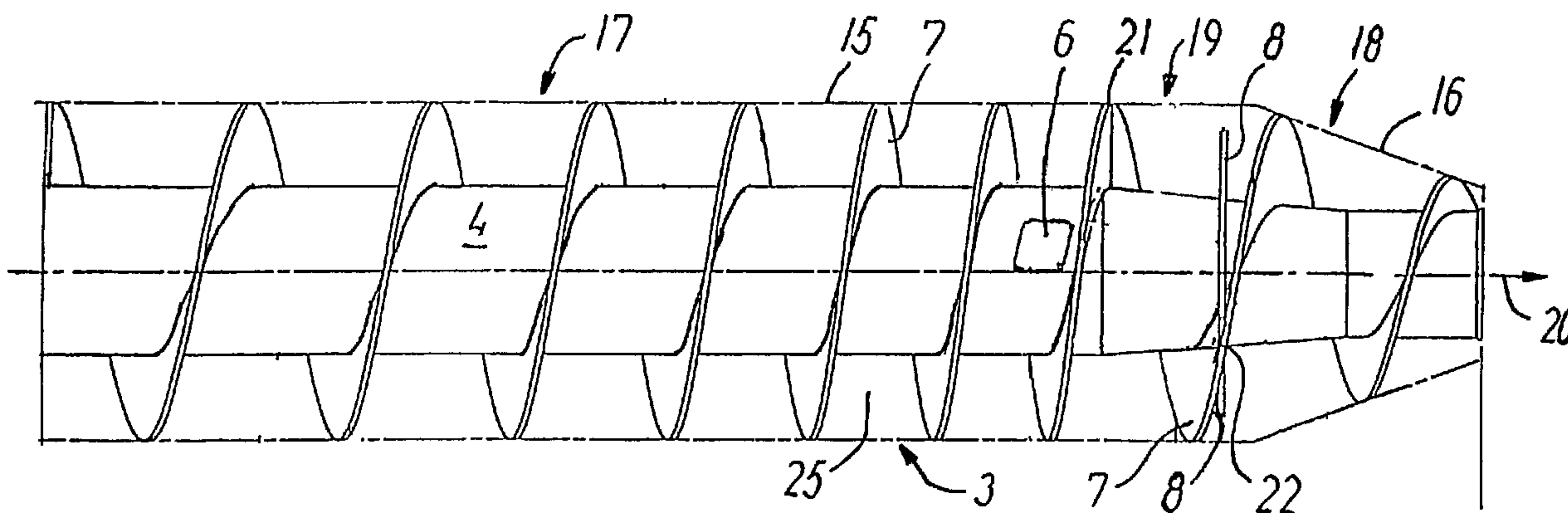

(86) Date de dépôt PCT/PCT Filing Date: 2003/04/09
 (87) Date publication PCT/PCT Publication Date: 2003/10/30
 (45) Date de délivrance/Issue Date: 2010/10/05
 (85) Entrée phase nationale/National Entry: 2004/09/28
 (86) N° demande PCT/PCT Application No.: DK 2003/000235
 (87) N° publication PCT/PCT Publication No.: 2003/089146
 (30) Priorité/Priority: 2002/04/22 (DK PA 2002 00598)

(51) Cl.Int./Int.Cl. *B04B 1/20* (2006.01)
 (72) Inventeurs/Inventors:
 DIRCKS, KLAUS, DK;
 MADSEN, BENT, DK
 (73) Propriétaire/Owner:
 ALFA LAVAL COPENHAGEN A/S, DK
 (74) Agent: MCCARTHY TETRAULT LLP

(54) Titre : CENTRIFUGEUSE DE DECANTATION
 (54) Title: A DECANTER CENTRIFUGE



(57) **Abrégé/Abstract:**

The decanter centrifuge comprises a screw conveyor having a body (4), which carries a screw comprising one or more flights (7, 7') and having a nominal transport speed varying along the longitudinal axis. An inlet (6) is provided in the screw conveyor for the material to be separated. The screw conveyor is provided with a baffle (8, 8') dividing the separation chamber in a substantially cylindrical separation part (17) and an at least partially conical discharge part (18). Immediately upstream of the baffle (8, 8') a transition part (19) is provided between the separation part (17) and the discharge part (18), the screw conveyor (3) having a bigger nominal transport speed in the transition part (19) than in the separation part (17) immediately before the transition part (19), the change of the nominal transport speed being established by a change (21) of the screw pitch.

(12) INTERNATIONAL APPLICATION PUBLISHED UNDER THE PATENT COOPERATION TREATY (PCT)

CORRECTED VERSION

(19) World Intellectual Property
Organization
International Bureau



(43) International Publication Date
30 October 2003 (30.10.2003)

PCT

(10) International Publication Number
WO 2003/089146 A1

(51) International Patent Classification⁷: **B04B 1/20**

(21) International Application Number:

PCT/DK2003/000235

(22) International Filing Date: 9 April 2003 (09.04.2003)

(25) Filing Language:

Danish

(26) Publication Language:

English

(30) Priority Data:

PA 2002 00598 22 April 2002 (22.04.2002) DK

(71) Applicant (for all designated States except US): **ALFA LAVAL COPENHAGEN A/S** [DK/DK]; Maskinvej 5, DK-2860 SØBORG (DK).

(72) Inventors; and

(75) Inventors/Applicants (for US only): **DIRCKS, Klaus** [DK/DK]; Gothersgade 93, 2th, DK-1123 Copenhagen K (DK). **MADSEN, Bent** [DK/DK]; Snogegaardsvej 29A, DK-2820 GENTOFTE (DK).

(74) Agents: **JØRGENSEN, Bjørn, Barker** et al.; International Patent-Bureau A/S, Høje Taastrup Boulevard 23, DK-2630 Taastrup (DK).

(81) Designated States (national): AE, AG, AL, AM, AT (utility model), AT, AU, AZ, BA, BB, BG, BR, BY, BZ, CA,

CH, CN, CO, CR, CU, CZ (utility model), CZ, DE (utility model), DE, DK (utility model), DK, DM, DZ, EC, EE (utility model), EE, ES, FI (utility model), FI, GB, GD, GE, GH, GM, HR, HU, ID, IL, IN, IS, JP, KE, KG, KP, KR, KZ, LC, LK, LR, LS, LT, LU, LV, MA, MD, MG, MK, MN, MW, MX, MZ, NI, NO, NZ, OM, PH, PL, PT, RO, RU, SC, SD, SE, SG, SK (utility model), SK, SL, TJ, TM, TN, TR, TT, TZ, UA, UG, US, UZ, VC, VN, YU, ZA, ZM, ZW.

(84) Designated States (regional): ARIPO patent (GH, GM, KE, LS, MW, MZ, SD, SL, SZ, TZ, UG, ZM, ZW), Eurasian patent (AM, AZ, BY, KG, KZ, MD, RU, TJ, TM), European patent (AT, BE, BG, CH, CY, CZ, DE, DK, EE, ES, FI, FR, GB, GR, HU, IE, IT, LU, MC, NL, PT, RO, SE, SI, SK, TR), OAPI patent (BF, BJ, CF, CG, CI, CM, GA, GN, GQ, GW, ML, MR, NE, SN, TD, TG).

Published:

— with international search report

(48) Date of publication of this corrected version:

15 April 2004

(15) Information about Correction:

see PCT Gazette No. 16/2004 of 15 April 2004, Section II

For two-letter codes and other abbreviations, refer to the "Guidance Notes on Codes and Abbreviations" appearing at the beginning of each regular issue of the PCT Gazette.

(54) Title: A DECANTER CENTRIFUGE

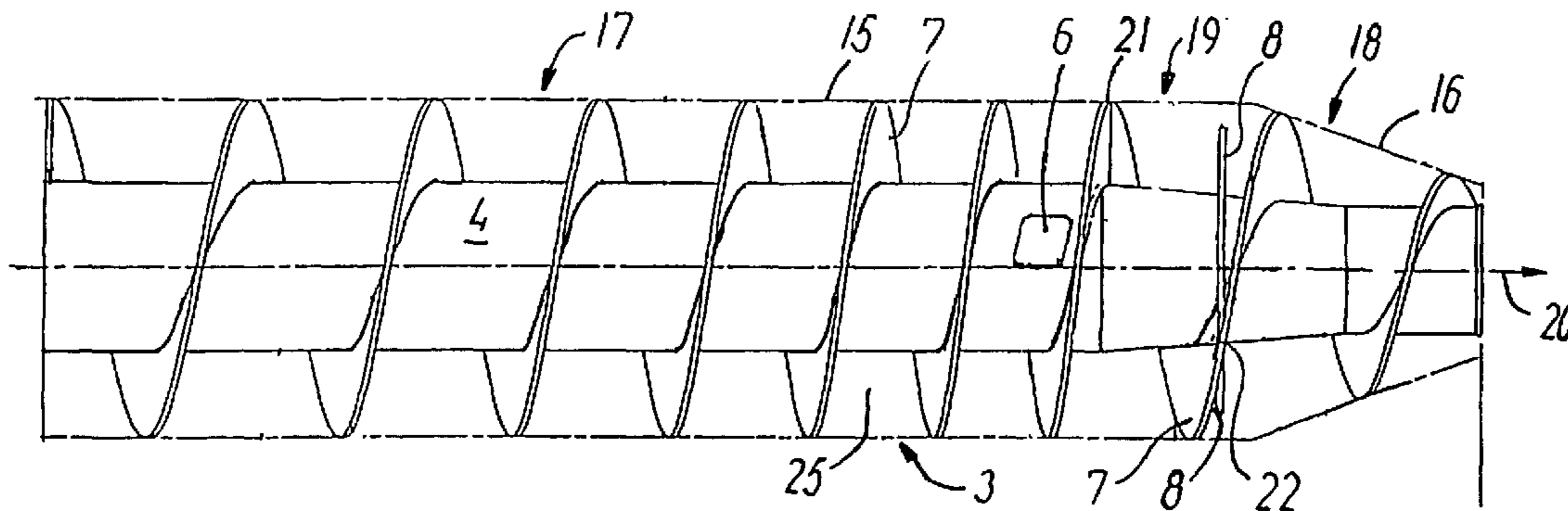

(57) Abstract: The decanter centrifuge comprises a screw conveyor having a body (4), which carries a screw comprising one or more flights (7, 7') and having a nominal transport speed varying along the longitudinal axis. An inlet (6) is provided in the screw conveyor for the material to be separated. The screw conveyor is provided with a baffle (8, 8') dividing the separation chamber in a substantially cylindrical separation part (17) and an at least partially conical discharge part (18). Immediately upstream of the baffle (8, 8') a transition part (19) is provided between the separation part (17) and the discharge part (18), the screw conveyor (3) having a bigger nominal transport speed in the transition part (19) than in the separation part (17) immediately before the transition part (19), the change of the nominal transport speed being established by a change (21) of the screw pitch.

WO 2003/089146 A1

A DECANTER CENTRIFUGE

The present invention relates to a decanter
5 centrifuge for separation of a supplied material in a
light phase and a heavy phase, comprising an elongate
bowl arranged for rotation about its longitudinal
axis, said bowl having a separation chamber, a screw
conveyor being provided in the separation chamber and
10 being coaxial with the bowl, said screw conveyor com-
prising a body, which carries a screw comprising one
or more flights and having a nominal transport speed
varying along the longitudinal axis, an inlet with at
least one inlet opening in the screw conveyor for
15 supply of the material to the separated, and at least
one discharge opening for the heavy phase in the bowl
at one end of the screw conveyor, in which the screw
conveyor is made to rotate relative to the bowl in
view of conveying the heavy phase towards the dis-
20 charge openings for the heavy phase, and in which the
screw conveyor is provided with a baffle positioned
between the inlet openings and the discharge open-
ings, said baffle dividing the separation chamber in
a substantially cylindrical separation part and an at
25 least partially conical discharge part, the discharge
openings for the heavy phase being positioned in the
discharge part, the inlet openings being positioned
at the opposite side of the baffle relative to said
discharge openings.

30 A decanter centrifuge of this kind is known
from WO-A-97/22411, which discloses a decanter cen-
trifuge having a baffle shaped as a rib extending
from the upstream side of a screw turn as a part of a

turn having a bigger pitch than the screw to the downstream side of a screw turn at an axial distance from its starting point.

US-A-3 934 792 discloses a decanter centrifuge 5 having a baffle extending axially from the upstream side of the screw turn to the downstream side of the adjacent screw turn. A similar baffle is described in US-A-5 653 673.

US-A-3 885 734, US-A-4 245 777 and US-A-4 381 10 849 disclose baffles extending tangentially around the screw conveyor.

The flight or flights of a screw conveyor defines/define a passageway between adjacent turns, through which material flows during the running of 15 the decanter centrifuge. A baffle is in general a member barring a part of the cross section of the passageway at a distance from the interior wall of the bowl. If only one flight is provided, it forms a single passageway winding around the body of the 20 screw conveyor, and the baffle will comprise a single member. If several flights are provided, a similar number of passageways will be defined between them, and the baffle will therefore comprise a member in each passageway.

25 In a decanter centrifuge a separation of the heavy phase and the light phase takes place in the separation part, whereby the light phase may be water and the heavy phase may be sludge to be drained off. The drained off sludge is conveyed by the screw 30 through the bowl to the baffle, under the baffle, i.e. between the baffle and the interior wall of the bowl, and to the discharge openings, where the comparatively dry sludge leaves the centrifuge, the baf-

file preventing the water or the light phase from reaching the discharge openings for the heavy phase.

The separation part and the part of the screw present therein are designed with a view to obtaining
5 the biggest possible efficiency of the drainage. However, an accumulation of the heavy phase immediately before the baffle may occur, partly on account of the throttling of the flow area of the heavy phase caused by the baffle, partly on account of the reduced area
10 in the conical discharge part, which acts backwards in such a manner that the separation process in the separation part does not get the intended course, which moreover entails a poorer process economy and a poorer drainage.

15 It is the object of the invention to reduce this problem.

This object is according to the invention met in that immediately upstream of the baffle, seen in relation to the transport direction, a transition
20 part is provided between the separation part and the discharge part, and that the screw conveyor has a bigger nominal transport speed in the transition part than in the separation part immediately before the transition part, the change of the nominal transport
25 speed of the screw from the nominal transport speed in the separation part immediately before the transition part to the higher nominal transport speed in the transition part being established by a change of the screw pitch.

30 By nominal transport speed for the screw is to be understood the speed, at which a given part of the screw would convey the heavy phase without disturbance from the surrounding parts of the screw, like

for instance downstream accumulation of heavy phase. The nominal transport speed depends in a non-linear way on the screw pitch and is highest at a pitch angle of approx. 45° relative to the tangential direction.
5 tion.

By designing the screw in accordance with the invention is attained that accumulation of the heavy phase in the discharge part will not take place to the same degree as would otherwise be the case. Let-
10 ting the increase of the transport speed take place before the baffle minimizes the risk of pulling to pieces the heavy phase, which at this point has the character of a coherent cake, which would entail a risk of the light phase breaking through to the dis-
15 charge part, which must be avoided, as it is tantamount to a re-wetting of the heavy phase just drained.

The change of the screw pitch may be abrupt, which may be convenient from a constructional point
20 of view, but the change of the screw pitch may alternatively be gradual.

In a preferred embodiment the pitch angle of the screw in the separation part is considerably smaller than 45° relative to the tangential direc-
25 tion, and the change of the screw pitch from the separation part to the transition part is an increase. This increase is preferably 40-80%.

In another embodiment the pitch angle of the screw in the separation part is considerably bigger
30 than 45° relative to the tangential direction, and the change of the screw pitch is a decrease from the separation part to the transition part.

To obtain full effect of the invention the

heavy phase, which is conveyed towards the baffle, should be conveyed at the increased speed over the whole peripheral extension of the baffle. Therefore, the screw has the bigger nominal transport speed over
5 at least $1/3 \times 1/n$ of a turn before the baffle, preferably over approximately $2/3 \times 1/n$ of a turn, n being the number of flights, corresponding to an axial length of $1/3$ and preferably $2/3$, respectively, of the pitch in the transition part, if there is only
10 one flight, or the axial distance between two adjacent turns, if several flights are present.

In an embodiment, in which the baffle has an axial extension, the border between the discharge part and the transition part is considered to be at
15 the centre point of the axial extension of the baffle.

The inlet is preferably placed upstream of the transition part in the separation part itself. In this way the risk of turbulence, on account of the
20 change of speed, disturbing the inlet flow is eliminated.

The screw pitch may be increasing in the separation part in a direction away from the transition part. In this manner known per se a decreasing
25 concentration of the heavy phase in a direction away from the inlet and the discharge part is compensated for.

The invention will now be explained in detail in the following by means of some examples of embodi-
30 ments and with reference to the drawings, in which

Fig. 1 in a somewhat schematic form shows a longitudinal section of a known decanter centrifuge having a bowl with a screw conveyor with an annular

baffle disc, and

Fig. 2 a screw conveyor in a first embodiment of the invention,

Fig. 3 a screw conveyor according to a second 5 embodiment, and

Fig. 4 a screw conveyor in a third embodiment according to the invention.

The decanter centrifuge 1 in Fig. 1 has a hollow bowl 2 with a separation chamber containing a 10 screw conveyor 3 having a body 4 with a screw with a flight 7, which is wound in a number of turns. The body 4 is substantially cylindrical and has a conical part 5 at one end. In the screw conveyor 3 inlet openings 6 for the material to be separated are pro- 15 vided, and in the bowl 2 discharge openings 14 for the separated heavy phase are provided. As indicated in the figure, the light phase 12 will be positioned closest to the body of the screw conveyor 4, whereas the heavy phase 13 is positioned at the interior side 20 of the bowl 2. The light phase is taken away via a discharge edge 10 on the bowl. The heavy phase is conveyed by the screw turn towards the discharge openings 14 in the bowl at its conical end. The figure shows a baffle 8 comprising an annular disc, 25 which is perpendicular to the longitudinal axis or axial direction of the screw conveyor.

Fig. 2 shows a screw conveyor 3, which as the screw conveyor in Fig. 1 is provided with a baffle 8 in the form of an annular disc and an inlet opening 30 6. Fig. 2 shows by broken lines the enveloping surface for the screw turns of the flight 7. The enveloping surface comprises a cylindrical part 15 and a conical part 16. The enveloping surface corresponds

with a suitable clear to the shape of the bowl, in which the screw conveyor is to be mounted.

The baffle 8 is positioned near the transition between the conical part 16 and the cylindrical part 5 15, and it divides substantially the centrifuge or the separation chamber in a cylindrical separation part 17 and a conical discharge part 18. In the embodiment the discharge part 18 comprises, however, a small portion of the cylindrical part 15.

10 The pitch of the screw turns varies along the screw conveyor 3 in its axial direction 20. Thus, there is at a point or at an axial position 21 an abrupt leap of the pitch of approximately 58%. The position 21 marks, on account of the change consti-
15 tuted by the leap, a dividing line between the separation part 17 and a transition part 19 between the separation part 17 and the discharge part 18.

The pitch is in the embodiment constant from the position 21 to the discharge openings for the
20 heavy phase.

The pitch of the screw turns in the separation part 17 is in this example decreasing in the axial direction 20 such that the pitch is smallest immediately before the transition part 19. The inlet 6 is
25 situated in the separation part 17 shortly before the transition part 19.

Fig. 3 shows another embodiment having a baffle 8 extending axially. The flight 7 of the screw conveyor 3 has in the position 21 a leap of the pitch,
30 which is consequently bigger in the transition part 19 than in the separation part 17. In the separation part 17 the pitch is constant. On account of the axial extension of the baffle 8, the dividing line be-

tween the transition part 19 and the discharge part 18 is considered to lie at the axial centre point 23 of the baffle. As the position 21 is somewhat downstream of the starting point 24 of the baffle, the position 21 will lie slightly more than a half pitch before the centre point 23 of the baffle. The pitch of the flight 7 is, in the screw conveyors described up till now, equal to the axial dimension of the passageway 25 formed between the adjacent turns of the flight 7, and the pitch angle of the flight 7 in the separation part 17 is substantially smaller than 45° relative to the tangential direction.

Fig. 4 shows an embodiment, in which the screw of the screw conveyor 3 has three flights 7' having a pitch angle substantially bigger than 45° relative to the tangential direction in the separation part 17. At an axial position 21' the pitch is changed, the pitch angle being changed in direction of 45° , following which the nominal transport speed increases.

At the position 21' a baffle member 8' extends from each flight 7', said baffle member extending as a part of a turn having a higher pitch than the flights 7' in the transition part 19 and the discharge part 18, but with the same rotational direction such that the baffle members 8' extend from a downstream side surface 26 of a flight 7' to an upstream side surface 27 of an adjacent flight 7'. In the embodiment shown in Fig. 4, the baffle members 8' have the same pitch as the flights 7' in the separation part, but that need not be the case.

The baffle members 8' extending from the position 21' and having a pitch smaller than 90° (axial direction), and the dividing line between the transi-

tion part 19 and the discharge part 18 being counted to lie at the axial centre point 23 of the baffle members, the leap regarding the nominal transport speed occurs more than $1/6$ ($1/2 \times 1/3$ (3 = the number of flights)) of a flight upstream of the transition part corresponding to more than half of the axial extension of a passageway 25 between two adjacent flights 7' in the transition part.

A centrifuge with a screw conveyor according to the invention works in the following way.

Material to be separated, for example aqueous sludge, is led into the separation chamber through the inlet 6. The sludge flows through the passageway 25 established by the flight 7 of the screw turn, or the passageways 25 established by the flights 7', towards the left of the figures. On its way, the heavy phase sediments, i.e. the sludge, as indicated in Fig. 1.

The screw conveyor 3 pulls on account of its rotation relative to the bowl 2 the sedimented sludge to the right of the figures (downstream direction). The sludge is compressed in the separation part 15 up to the axial position 21. At this point, the sludge forms a coherent, comparatively dry cake.

From the position 21 the sludge is accelerated on account of the change of the pitch of the flight 7 or the flights 7'. The position 21 is in the embodiment in Fig. 2 positioned approximately $2/3$ turn before the intersection point 21 of the screw turn 7 with the baffle 8 corresponding to an axial distance between the position 21 and the point 22 of $2/3$ of the pitch of the screw turn or the axial dimension of the passageway at this point. In the embodiments in

Figs 3 and 4, the position 21 is positioned a little bit more than 1/2 time the axial dimension of the passageway 25 upstream of the axial centre point 23 of the baffle 8 or the baffle members 8'. In this manner the changing point of the transport speed is situated sufficiently far from the baffle 8, 8' to convey the sludge along the periphery of the entire baffle at the increased speed.

The space between the periphery of the baffle 8 and the interior wall of the bowl 2 is smaller than the thickness of the sludge at the point 21. The increased speed in the transition part 19 compensates to a certain degree for this difference. However, compensation is somewhat below 100%, as a compensation of 100% or more could entail the risk that the sludge cake might be pulled to pieces, which may result in a break through of the light phase under and past the baffle 8.

The increased speed also compensates for the reduced cross-section area of the conical part of the bowl 2 in the discharge part 18.

Though different embodiments of screw conveyors according to the invention have been described herein, said embodiments having different combinations of flight numbers and pitch angles and baffle types, it should be understood that in particular flight pitch angles and type of baffle may be combined in any way within the scope of the invention.

-11-

C L A I M S

1. A decanter centrifuge for separation of a supplied material in a light phase and a heavy phase, comprising an elongate bowl arranged for rotation about its longitudinal axis, said bowl having a separation chamber, a screw conveyor being provided in the separation chamber and being coaxial with the bowl, said screw conveyor comprising a body, which carries a screw comprising one or more flights and having a nominal transport speed varying along the longitudinal axis, an inlet with at least one inlet opening in the screw conveyor for supply of the material to the separated, and at least one discharge opening for the heavy phase in the bowl at one end of the screw conveyor, in which the screw conveyor is made to rotate relative to the bowl in view of conveying the heavy phase towards the discharge openings for the heavy phase, and in which the screw conveyor is provided with a baffle positioned between the inlet openings and the discharge openings, said baffle dividing the separation chamber in a substantially cylindrical separation part and an at least partially conical discharge part, the discharge openings for the heavy phase being positioned in the discharge part, the inlet openings being positioned at the opposite side of the baffle relative to said discharge openings, wherein immediately upstream of the baffle, seen in relation to the transport direction, a transition part is provided between the separation part and the discharge part, and that the screw conveyor has a bigger nominal transport speed in the transition part than in the separation part immediately before the transition part, the change of the nominal transport speed of the screw from the nominal transport

-12-

speed in the separation part immediately before the transition part to the higher nominal transport speed in the transition part being established by a change of the screw pitch.

5

2. The decanter centrifuge according to claim 1, wherein the change of the screw pitch is abrupt.

3. The decanter centrifuge according to claim 1,
10 wherein the change of the screw pitch is gradual.

4. The decanter centrifuge according to any one of claims 1 to 3, wherein the pitch angle of the screw in the separation part is considerably smaller than 45° relative
15 to the tangential direction and that the change of the screw pitch is an increase.

5. The decanter centrifuge according to claim 4,
wherein said increase is 40-80%.

20

6. The decanter centrifuge according to any one of claims 1 to 3, wherein the pitch angle of the screw in the separation part is considerably bigger than 45° relative to the tangential direction and that the change of the screw
25 pitch is a decrease.

-13-

7. The decanter centrifuge according to any one of claims 1 to 6, wherein the screw has the bigger nominal transport speed over at least $1/3 \times 1/n$ of a turn before the baffle, preferably over approximately $2/3 \times 1/n$ of a turn, n being the number of flights.

8. The decanter centrifuge according to any one of claims 1 to 7, wherein the inlet is placed upstream of the transition part in the separation part.

10

9. The decanter centrifuge according to any one of claims 1 to 8, wherein the baffle has an axial extension, the border between the discharge part and the transition part being positioned at the centre point of the axial extension of the baffle.

15

10. The decanter centrifuge according to any one of claims 1 to 9, wherein the screw pitch is increasing in the separation part in a direction away from the transition part.

20

1/3

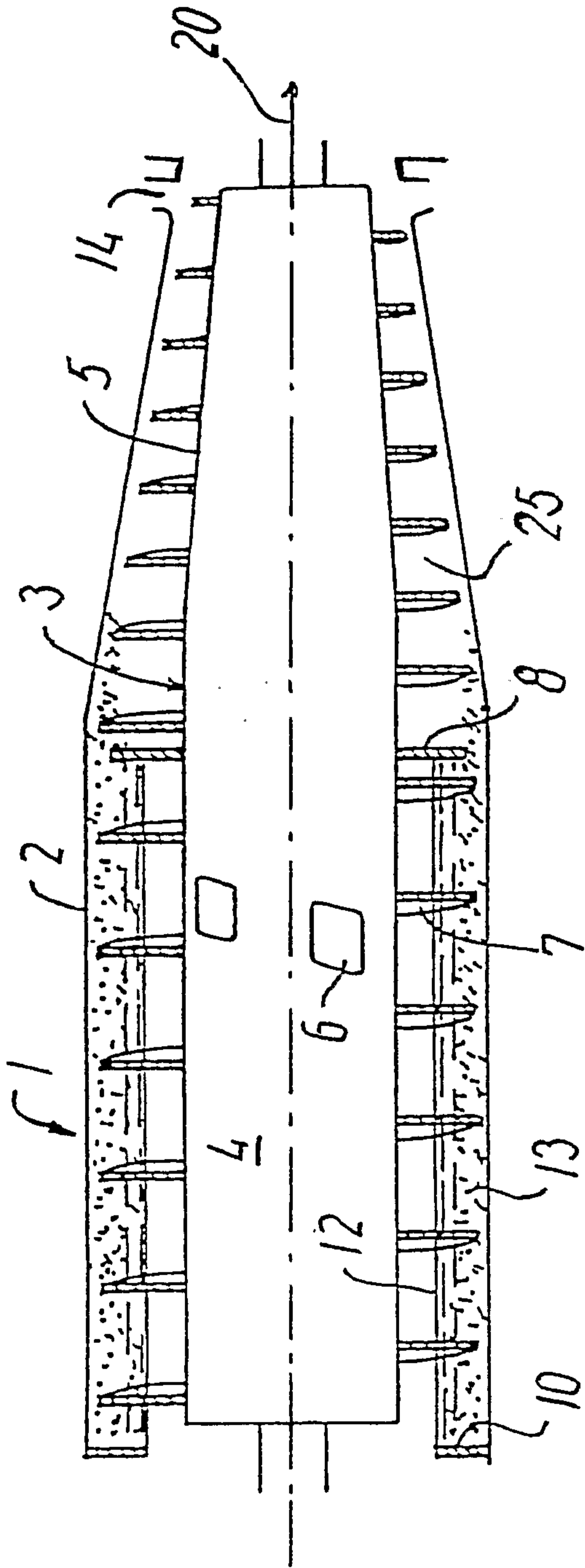

FIG. 1

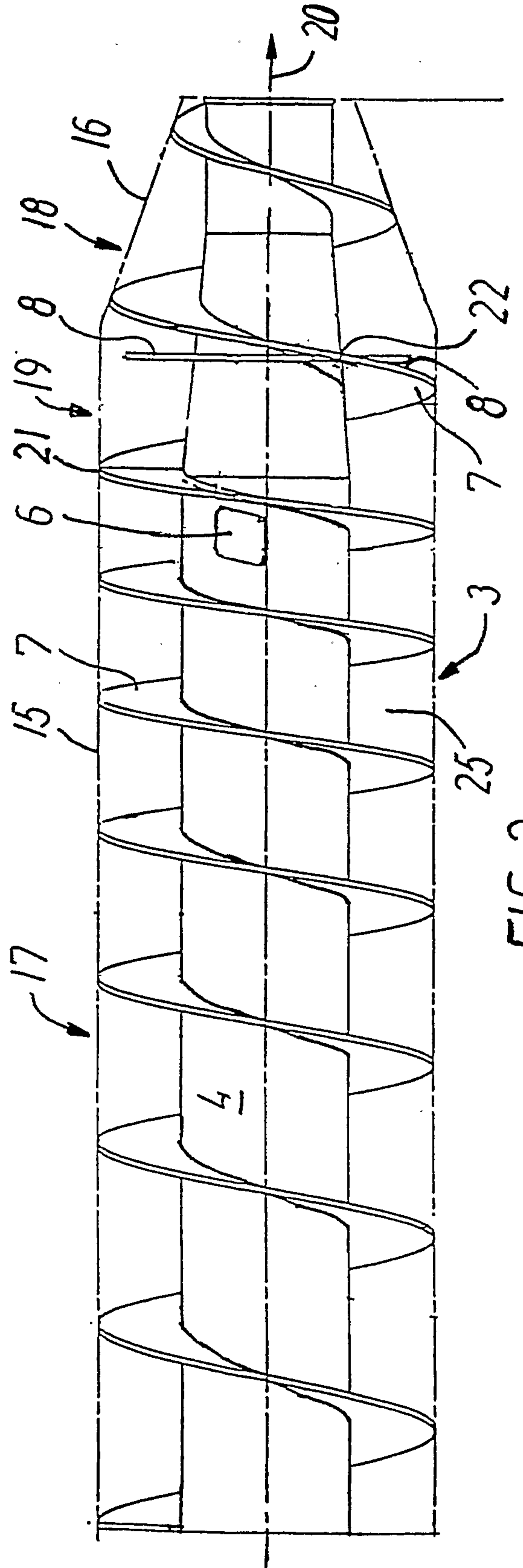

FIG. 2

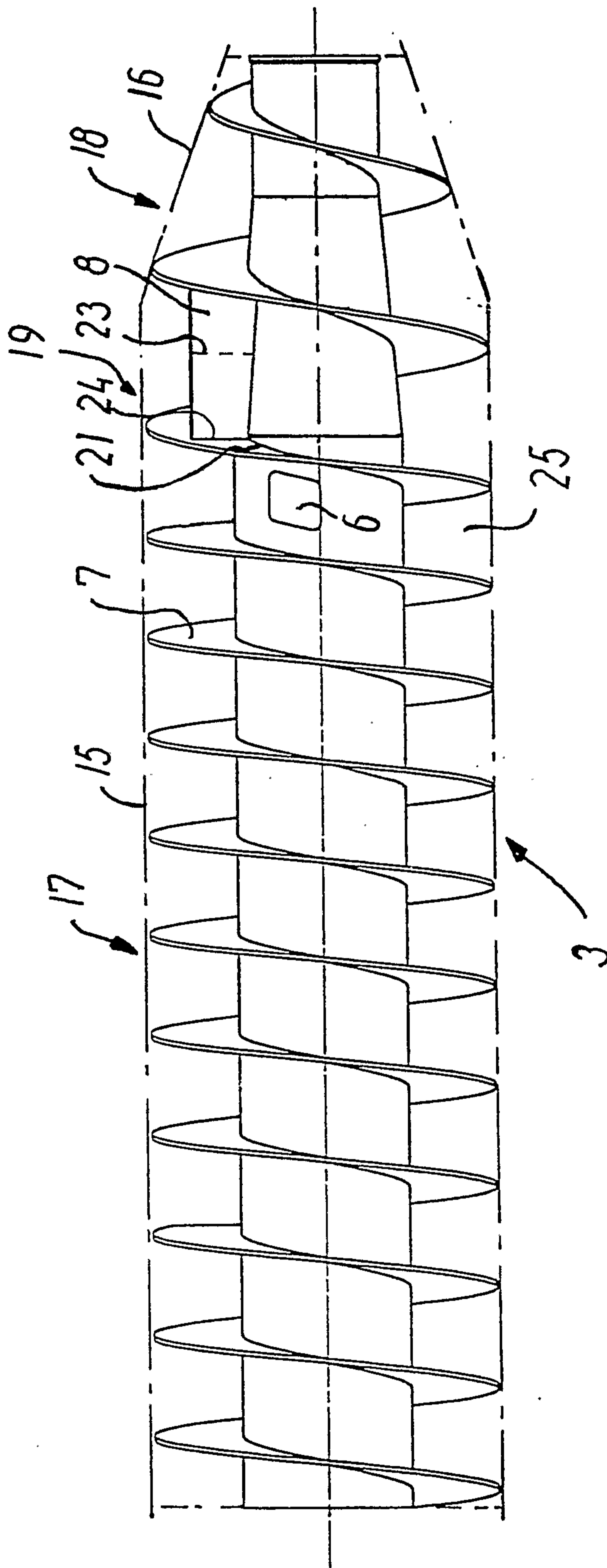

FIG. 3

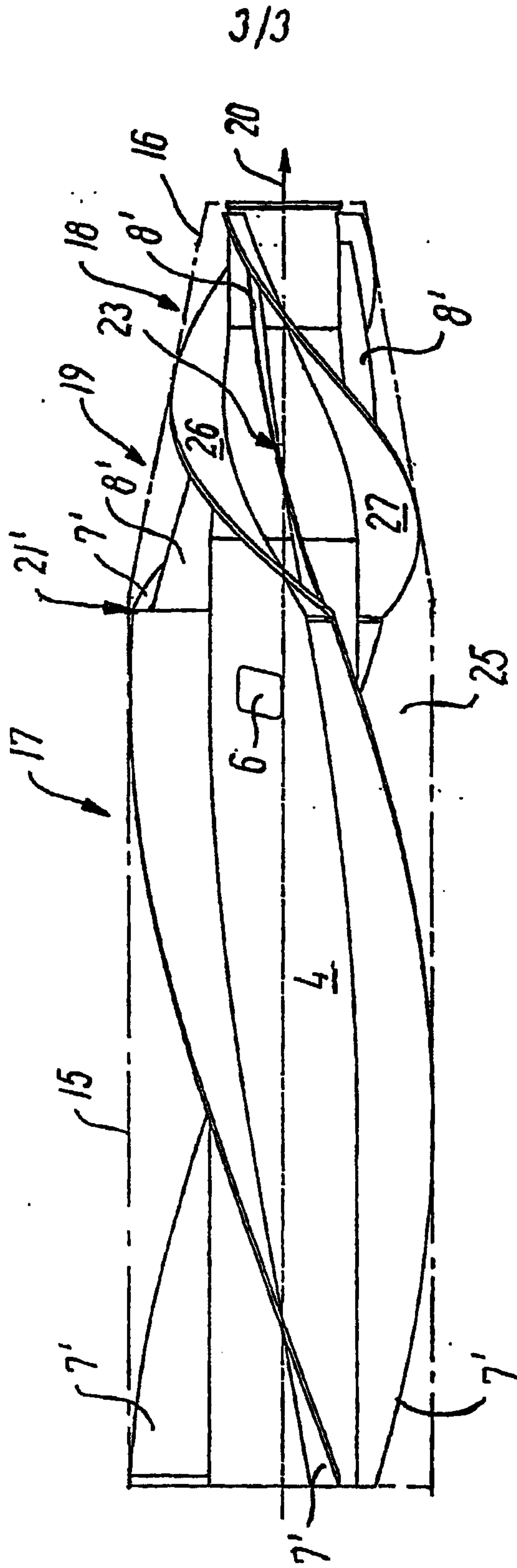

FIG. 4

