

F. THOMAS.
MACHINE FOR BENDING SHEET METAL.

(Application filed Feb. 12, 1900.)

(No Model.)

2 Sheets—Sheet 1.

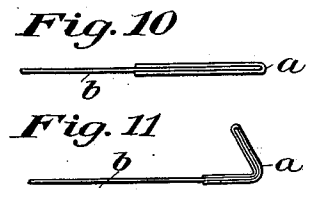
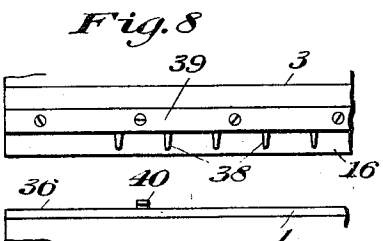
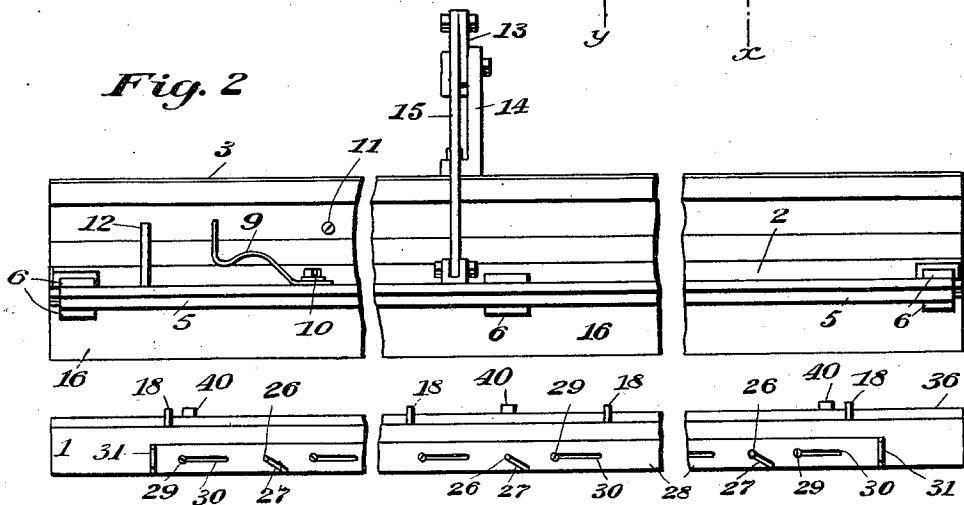
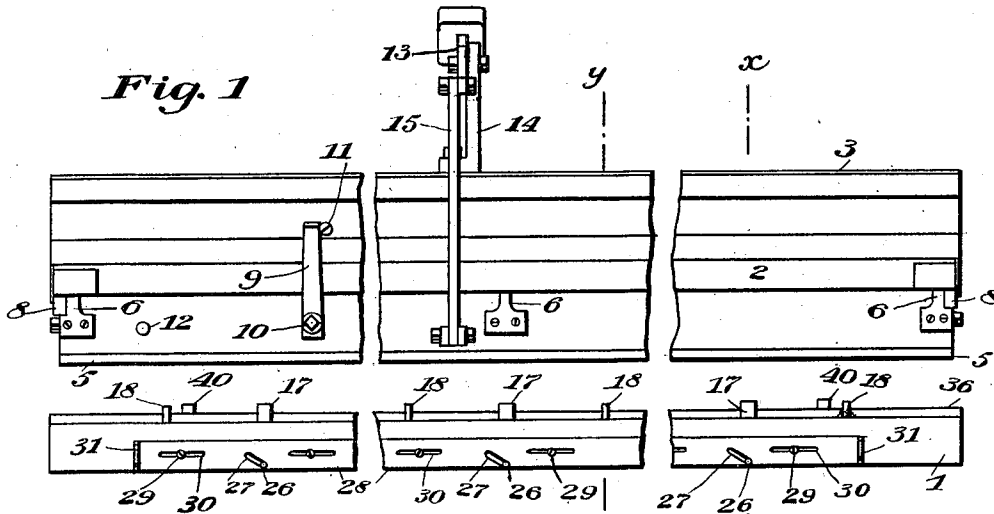

Witnesses
J. B. Thomas
J. M. Robinson



Inventor
 Francis Thomas,
 by *John Elias Jones*,
 his Attorney.

F. THOMAS.
MACHINE FOR BENDING SHEET METAL.

(Application filed Feb. 12, 1900.)

(No Model.)

2 Sheets—Sheet 2

Fig. 3

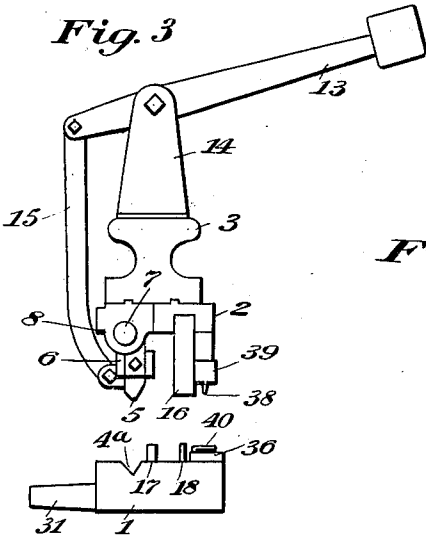

Fig. 4

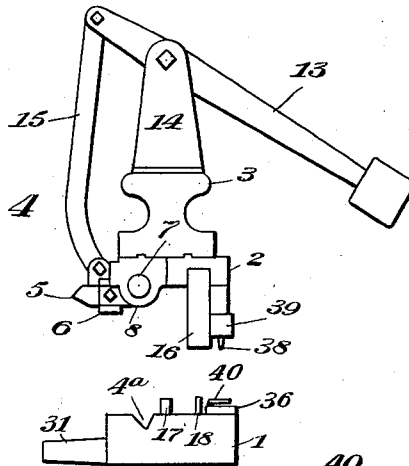

Fig. 5

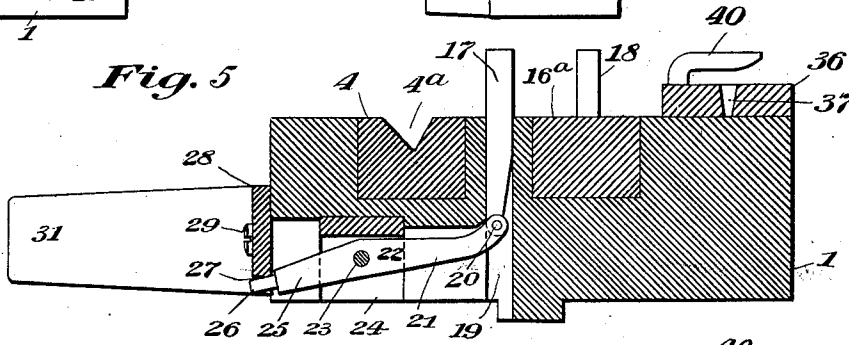

Fig. 6

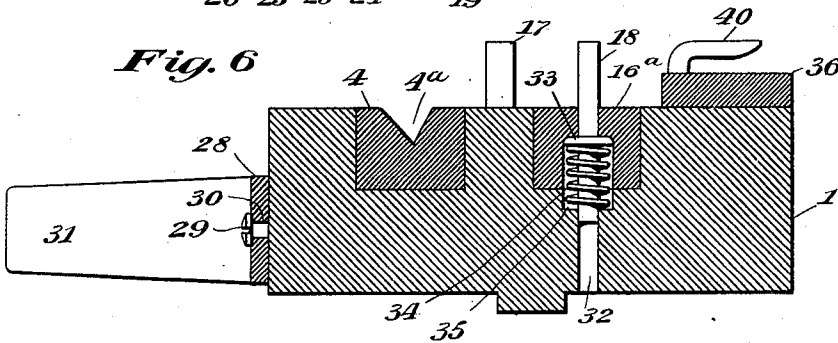
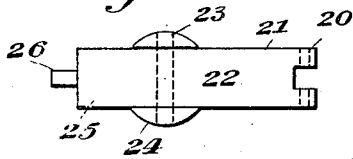

Fig. 7



Witnesses

J. D. Home
J. M. Robinson

Inventor

Francis Thomas,
by John Elias Jones,
his attorney.

UNITED STATES PATENT OFFICE.

FRANCIS THOMAS, OF CINCINNATI, OHIO.

MACHINE FOR BENDING SHEET METAL.

SPECIFICATION forming part of Letters Patent No. 658,077, dated September 18, 1900.

Application filed February 12, 1900. Serial No. 4,904. (No model.)

To all whom it may concern:

Be it known that I, FRANCIS THOMAS, a citizen of the United States of America, and a resident of Cincinnati, in the county of Hamilton and State of Ohio, have invented certain new and useful Improvements in Machines for Bending Sheet Metal, of which the following is a specification.

This invention relates to certain improvements in machines for bending sheet metal, and has for its object to provide a machine of this character of a simple, strong, and inexpensive nature which shall be adapted to operate successively upon the sheet metal in a manner to produce a plurality of bends in the same, so as to permit of the use of a single machine for imparting to the finished work cross-sectional forms which could otherwise be imparted only with the aid of a number of machines.

The invention consists in certain novel features of the construction, combination, and arrangement of the several parts of the improved bending-machine, whereby certain important advantages are attained and the device is made simpler, cheaper, and otherwise better adapted and more convenient for use, all as will be hereinafter fully set forth.

The novel features of the invention will be carefully defined in the claims.

In the accompanying drawings, which serve to illustrate my invention, Figure 1 is an elevation showing the operative parts of a machine constructed according to my invention, portions of the same being broken away and omitted for lack of space. Fig. 2 is a view similar to Fig. 1, but showing the upper or movable die adjusted out of position for use. Fig. 3 is an end view showing the parts as they appear in Fig. 1. Fig. 4 is an end view showing the parts as they appear in Fig. 2. Fig. 5 is an enlarged section taken transversely through the lower die member or bed in the plane indicated by line *xx* in Fig. 1. Fig. 6 is a view similar to Fig. 5, but taken in the plane indicated by the line *yy* in Fig. 1. Fig. 7 is an enlarged detail view showing one of the lever devices for operating the gages for the dies. Fig. 8 is a partial rear view of the upper and lower die members. Fig. 9 is a view showing the cross-sectional

form given to the sheet metal at the first operation of the machine. Fig. 10 is a view showing the cross-sectional form given to the sheet metal at the second operation of the machine. Fig. 11 is a view showing the cross-sectional form given to the sheet metal at the third operation of the machine. Fig. 12 is a view showing the cross-sectional form given to the sheet metal at the fourth operation of the machine.

In the drawings, 1 indicates the lower die member or bed of the machine, and 2 the upper die member, held to reciprocate vertically over the bed 1 on a plunger 3, having suitable operating devices and guides, (not shown,) which form no part of the present invention, but permit of such reciprocating motion toward and away from the bed. The bed or lower member 1 is formed near its front edge with a longitudinal recess on its upper face, which recess serves to receive a lower female die 4, having a longitudinal V-shaped groove or channel 4^a in its upper face, with which groove is adapted to register an upper male die 5, carried on the upper member 2, as clearly shown in Figs. 1 to 4. The upper male die 5 is carried by hangers 6 upon a shaft 7, extended longitudinally beneath the upper member 2 and supported in bearings 8 thereon, by which means said die 5 is permitted to be swung pivotally on said shaft to a vertical position, as shown in Figs. 1 and 3, when it is adapted for registry with the groove 4^a of the lower die 4, or to a horizontal position, as shown in Figs. 2 and 4, whereupon it is out of operative position with respect to said lower die 4. To hold said upper die 5 in its vertical or operative position, I provide a lever 9, pivoted, as shown at 10, on the upper member 2 and adapted to be swung pivotally, so as to engage the side surface of the plunger 3, whereupon it contacts with a stop 11 and locks the upper male die against pivotal movement on shaft 7. A handle 12 is also provided for moving the die 5 pivotally on its shaft, and in order to automatically move said die 5 out of operative position when released by the downward movement of lever 9 I provide a device (clearly shown in Figs. 3 and 4) comprising a weighted lever 13, pivoted on a bracket 14 at the center of plunger 3 and

coupled by a link 15 to said die. The weight on lever 13 acts to counterbalance the die 5 when the same is released and serves to move the same pivotally on its shaft to a horizontal position, as shown in Figs. 2 and 4. The upper member 2 also carries at the rear of the die 5 and in line with the same a hammer 16, formed of a flat metal blade extended lengthwise of said member and having its lower surface arranged parallel with the upper face of the bed, which is plane beyond the V-shaped groove 4^a. A strip 16^a is inserted in the bed 1 beneath the hammer 16 and serves as a rest for the metal while being operated on by the same.

Gages 17 and 18 are provided for use in connection, respectively, with the dies 4 and 5 and with the hammer 16, there being a plurality of gages for each arranged in a series lengthwise of the bed 1. The gages 17 are of the construction shown in Fig. 5 and are adjustable into and out of operative position, so as not to be in the way of the metal when operated on by the hammer 16, the die 5 being then swung out of operative position. Each gage 17 consists of a metal pin movable in a vertical opening 19 in the bed just at the rear of die 4 and connected at its lower end, as shown at 20, to one arm 21 of a lever 22, pivoted, as shown at 23, in a slotted block 24, held in a recess in the under side of the bed, as shown in Figs. 5 and 7. The other end of said lever 22 is indicated at 25, and is provided with a pin or stud 26, extended from the front face of the bed, which latter is slotted for the movement of said levers, and said pin has engagement with an inclined or cam slot 27 in a slide 28, held on the bed by screws 29 or the like, which engage slots 30 in said slide to permit the necessary movement of the slide. The slide has bent end portions 31, forming handles by means of which the operator may conveniently move the slide in one direction or the other in order to adjust the gages 17 into and out of position for use. When out of use, the gages 17 have their upper ends flush with the bed, so as to offer no obstruction to the passage of the work over them to be operated upon by the hammer 16. The gages 18 are of the construction shown in Fig. 6, being each formed of a pin movable in a vertical opening 32 just beneath the hammer 16, and each pin has an enlargement or collar 33, beneath which is held a spiral spring 34, coiled on the pin within a chamber 35 in the bed and of a size to receive both the collar 33 and the spring 34. By this construction when the hammer 16 is caused to descend toward the bed its lower face on contact with the gage-pins 18 depresses the same in the openings 32 in the bed, compressing the springs 34 beneath the collars 33, and when the hammer is caused to ascend the springs 34 react, so as to again raise the gage-pins into operative position.

A perforating device is also provided for

perforating the sheet metal, and this device is preferably arranged at the rear of the machine and is operated by a workman standing at the back of the machine, so that the machine may be used simultaneously for both the bending and perforating operations, although this is not essential to my invention. As herein shown, the perforating device comprises a die 36, secured to the bed 1 and raised above the same at the rear of the hammer 16 and provided with openings 37 to receive pins 38 on a bar 39, extended along the rear face of the hammer, to which it is secured. The die 36 is also provided with strippers 40 to strip the work from the pins 38 upon the upward movement of the hammer.

The machine constructed as above described is of an extremely simple and inexpensive nature and is especially well adapted for use, since it permits of successively operating on the sheet metal, so as to give to the finished work cross-sectional forms which could not otherwise be had except by the use of a number of machines.

The machine is especially well adapted for use in applying metallic bindings to the edges of woven-wire fabric and similar articles, and when used for such purposes the operation is as follows: The sheet metal in strip form is first applied between the dies 4 and 5, the gages 17 being raised, as shown in Fig. 5, by properly moving the slide 28 and the swinging die 5 being held in vertical position, so that on its descent the sheet-metal strip will be centrally bent to a V shape, as seen at *a* in Fig. 9. If desired, a number of strips *a* may be thus bent prior to applying any of them to the articles to be bound. When it is desired to apply the bent strip *a* to an article, it is first slipped over the edge of the article, and the die 5 being moved to its horizontal position and gages 17 being lowered by properly moving the slide 28 the edge of the article to be bound together, with the strip *a* applied loosely thereon, is inserted between the bed 1 and the hammer 16 against the gages 18. Upon the descent of the hammer the bent V-shaped strip *a* will be flattened out on the edge of the article *b*, as shown in Fig. 10. The article *b* is then drawn forward from beneath the hammer, the gages 17 are raised, and the swinging die 5 is again set in lowered position, so that when the article is pressed against the gages 17 and the die 5 lowered the edge of the article, together with the strip *a* applied thereto, will be again centrally bent to a V form, as shown in Fig. 11. The die 5 is now again raised and the gages 17 lowered, permitting the bent edge to be pushed back against the gages 18 and beneath the hammer 16, which upon its descent again flattens the V bend in the edge of the article, producing a four-ply binding; as shown in Fig. 12. The articles *b* after having been bound may have their edges or bindings perforated, when desired, by placing the bound

edges beneath the bar 39 on die 36, the descending pins 38 perforating the bound edges, as will be obvious.

It will also be apparent from the above description that the machine is capable of some modification without material departure from the principles and spirit of the invention, and for this reason I do not wish to be understood as limiting myself to the precise form and arrangement of the several parts herein set forth.

Having thus described my invention, I claim—

1. In a machine of the character described, the combination of two members, one movable toward and away from the other and a plurality of forming devices carried by one member, one of said forming devices being rigidly held on its member and the other forming device on said member being adjustable into and out of operative position, substantially as set forth.

2. In a machine of the character described, the combination of two members, one movable toward and away from the other, a plurality of forming devices carried by one member, one of said forming devices being rigidly held on its member and the other forming device on said member being adjustable into and out of operative position, and a gage arranged for operation in connection with the adjustable forming device and also adjustable into and out of operative position, substantially as set forth.

3. In a machine of the character described, the combination of two members, one movable toward and away from the other, a plurality of forming devices carried by one member, one of said forming devices being adjustable into and out of operative position, means for moving the adjustable forming device, when released, out of operative position, and means adapted to hold said adjustable forming device in operative position during the movement of the member by which it is carried, substantially as set forth.

4. In a machine of the character described, the combination of two members, one movable toward and away from the other, and a forming device pivotally held on one member and adapted to be adjusted into and out of operative position and provided with means adapted to hold it out of operative position when so adjusted, substantially as set forth.

5. In a machine of the character described, the combination of two members, one movable toward and away from the other, a hammer and a die carried by one member in line with each other, one of said last-named parts being movable into and out of operative position and being provided with means adapted to hold it out of operative position when so moved, substantially as set forth.

6. In a machine of the character described, the combination of two members, one movable toward and away from the other, a shaft carried by one member, and a die held to swing

on said shaft and provided with means adapted to hold it against movement when out of operative position, substantially as set forth.

7. In a machine of the character described, the combination of two members, one movable toward and away from the other, a gage, a slide, and means actuated from the slide for moving the gage into and out of operative position, substantially as set forth.

8. In a machine of the character described, the combination of two members, one movable toward and away from the other, a gage, a lever connected to the gage and a slide having a cam engaged with the lever to move the gage, substantially as set forth.

9. In a machine of the character described, the combination of two members, one movable toward and away from the other, dies carried by the respective members, a hammer carried by one member and a perforating device carried by one member, substantially as set forth.

10. In a machine of the character described, the combination of two members one movable toward and away from the other, corresponding dies carried by the respective members, one of said dies being movable into and out of operative position, and a hammer carried by one member and adapted for operation when the movable die is out of operative position, substantially as set forth.

11. In a machine of the character described, the combination of two members, one movable toward and away from the other, two forming devices carried by one member and adapted for operation in connection with corresponding forming devices on the other member when the members are moved relatively to each other, one of said forming devices being in front of the other and being adapted for movement out of and into operative position, substantially as set forth.

12. In a machine of the character described, the combination of two members, one movable toward and away from the other, two forming devices carried by one member and adapted for operation in connection with corresponding devices on the other member when the members are moved relatively to each other, one of said forming devices being in front of the other and being movable into and out of operative position, and a gage adapted for use in connection with the movable forming device and also adapted to be moved out of operative position, substantially as set forth.

13. In a metal-bending machine, a member having two forming devices, one of which is arranged in front of the other and is movable into and out of operative position, substantially as set forth.

Signed by me at Cincinnati, Ohio, this 2d day of February, 1900.

FRANCIS THOMAS.

Witnesses:

J. M. ROBINSON,
JOHN ELIAS JONES.