

(19) World Intellectual Property Organization  
International Bureau



(43) International Publication Date  
18 October 2007 (18.10.2007)

PCT

(10) International Publication Number  
WO 2007/117316 A2

- (51) International Patent Classification:  
E21B 36/00 (2006.01)
- (21) International Application Number:  
PCT/US2006/061688
- (22) International Filing Date:  
6 December 2006 (06.12.2006)
- (25) Filing Language: English
- (26) Publication Language: English
- (30) Priority Data:  
11/296,202 6 December 2005 (06.12.2005) US
- (71) Applicant and  
(72) Inventor: HILL, William, L. [US/US]; 23 Estates Court,  
Longview, TX 75605 (US).
- (74) Agents: HENRY, David, G. et al.; Cox Smith Matthews  
Incorporated, 112 East Pecan Street, Suite 1800, San An-  
tonio, TX 78205 (US).
- (81) Designated States (unless otherwise indicated, for every  
kind of national protection available): AE, AG, AL, AM,

AT, AU, AZ, BA, BB, BG, BR, BW, BY, BZ, CA, CH, CN, CO, CR, CU, CZ, DE, DK, DM, DZ, EC, EE, EG, ES, FI, GB, GD, GE, GH, GM, GT, HN, HR, HU, ID, IL, IN, IS, JP, KE, KG, KM, KN, KP, KR, KZ, LA, LC, LK, LR, LS, LT, LU, LV, LY, MA, MD, ME, MG, MK, MN, MW, MX, MY, MZ, NA, NG, NI, NO, NZ, OM, PG, PH, PL, PT, RO, RS, RU, SC, SD, SE, SG, SK, SL, SM, SV, SY, TJ, TM, TN, TR, TT, TZ, UA, UG, US, UZ, VC, VN, ZA, ZM, ZW.

- (84) Designated States (unless otherwise indicated, for every kind of regional protection available): ARIPO (BW, GH, GM, KE, LS, MW, MZ, NA, SD, SL, SZ, TZ, UG, ZM, ZW), Eurasian (AM, AZ, BY, KG, KZ, MD, RU, TJ, TM), European (AT, BE, BG, CH, CY, CZ, DE, DK, EE, ES, FI, FR, GB, GR, HU, IE, IS, IT, LT, LU, LV, MC, NL, PL, PT, RO, SE, SI, SK, TR), OAPI (BF, BJ, CF, CG, CI, CM, GA, GN, GQ, GW, ML, MR, NE, SN, TD, TG).

Published: — without international search report and to be republished upon receipt of that report

[Continued on next page]

(54) Title: IMPROVED DOWN HOLE OIL AND GAS WELL HEATING SYSTEM AND METHOD FOR DOWN HOLE HEATING OF OIL AND GAS WELLS

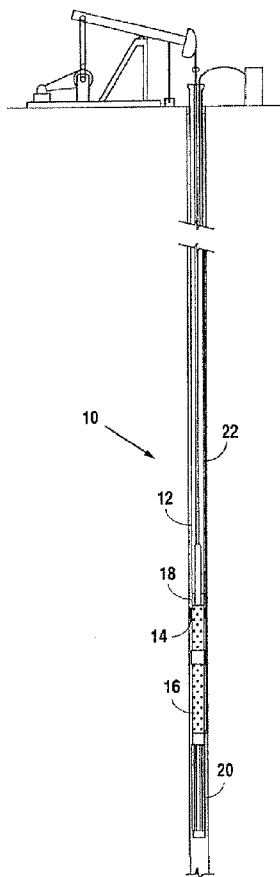

(57) Abstract: A down hole heating system for use with oil and gas wells which exhibit less than optimally achievable flow rates because of high oil viscosity and/or blockage by paraffin (or similar meltable petroleum byproducts). The heating unit of the present invention includes shielding to prevent physical damage and shortages to electrical connections within the heating unit while down hole (a previously unrecognized source of system failures in prior art systems). The over-all heating system also includes heat retaining components to focus and contain heat in the production zone to promote flow to, and not just within, the production tubing.

WO 2007/117316 A2



---

*For two-letter codes and other abbreviations, refer to the "Guidance Notes on Codes and Abbreviations" appearing at the beginning of each regular issue of the PCT Gazette.*

**TITLE: IMPROVED DOWN HOLE OIL AND GAS WELL HEATING  
SYSTEM AND METHOD FOR DOWN HOLE HEATING OF OIL AND GAS  
WELLS**

**INVENTOR: WILLIAM L. HILL**

**CITATION TO PRIOR APPLICATION**

This is a continuation-in-part with respect to U.S. Patent Application, Serial No. 11/041,525, filed on January 24, 2005; which is a continuation-in-part with respect to U.S. Patent Application, Serial No. 10/763,568, filed on January 23, 2004; which is a continuation-in-part with respect to issued U.S. Patent 6,681,859, filed on October 22, 2001.

**BACKGROUND OF THE INVENTION**

1. Field of the Invention:

The present invention relates to systems and methods for producing or delivering heat at or near the down hole end of production tubing of a producing oil or gas well for improving production therefrom.

2. Background Information:

Free-flowing oil is increasingly difficult to find, even in oil wells that once had very good flow. In some cases, good flowing wells simply "clog up" with paraffin. In other cases, the oil itself in a given formation is of a viscosity that it simply will not flow (or will flow very slowly) under naturally ambient temperatures. Because the viscosity of oil and paraffin have an inverse relationship to their temperatures, the solution to non-flowing or slow flowing oil wells would seem fairly straight forward -- somehow heat the oil and/or paraffin. However, effectively achieving this objective has proven elusive for many years.

In the context of gas wells, another phenomena -- the buildup of iron oxides and other residues that can obstruct the free flow of gas through the perforations, through the tubing, or both -creates a need for effective down hole heating.

Down hole heating systems or components for oil and gas wells are known (hereafter, for the sake of brevity, most wells will simply be referred to as "oil wells" with the understanding that certain applications will apply equally well to gas wells).

In addition, certain treatments (including "hot oil treatments") for unclogging no-flow or slow-flow oil wells have long been in use. For a variety of reasons, the existing technologies are very much lacking in efficacy and/or long-term reliability.

The present invention addresses two primary shortcomings that the inventor has found in conventional approaches to heating oil and paraffin down hole: (1) the heat is not properly focused where it needs to be; and (2) existing down hole heaters fail for lack of design elements which would protect electrical components from chemical or physical attack while in position.

The present inventor has discovered that existing down hole heaters inevitably fail because their designers do not take into consideration the intense pressures to which the units will be exposed when installed. Such pressure forces liquids (including highly conductive salt water) past the casings of conventional heating units and causes electrical shorts and corrosion. Designers with whom the present inventor has discussed heater failures have uniformly failed to recognize the root cause of the problem -- lack of adequate protection for the heating elements and their electrical connections. The down hole heating unit of the present invention addresses this shortcoming of conventional heating units.

Research into the present design also reveals that designers of existing heaters and installations have overlooked crucial features of any effective down hole heater system: (1) it must focus heat in such a way that the production zone of the formation itself is heated; and (2) heat (and with it, effectiveness) must not be lost for failure to insulate heating elements from up hole components which "draw" heat away from the crucial zones by conduction.

However subtle the distinctions between the present design and those of the prior art might at first appear, actual field applications of the present down hole heating system have yielded oil well flow rate increases which are multiples of those realized through use of presently available down hole heating systems. The monetary motivations for solving slow-flow or no-flow oil well conditions are such that, if modifying existing heating units to achieve the present design were obvious, producers would not have spent millions of dollars on ineffective down hole treatments and heating systems (which they have done), nor lost millions of dollars in production for lack of the solutions to long-felt problems that the present invention

provides (which they have also done).

### **SUMMARY OF THE INVENTION**

It is an object of the present invention to provide an improved down hole heating system for use in conditioning oil and gas wells for increased flow, when such flow is impeded because of viscosity and/or paraffin blockage conditions.

It is another object of the present invention to provide an improved design for down hole heating systems which has the effect of more effectively focusing heat where it is most efficacious in improving oil or gas flow in circumstances when such flow is impeded because of oil viscosity and/or paraffin blockage conditions.

It is another object of the present invention to provide an improved design for down hole heating systems for oil and gas wells which design renders the heating unit useful for extended periods of time without interruption for costly repairs because of damage or electrical shorting caused by unit invasion by down hole fluids.

It is another object of the present invention to provide an improved method for down hole heating of oil and gas wells for increasing flow, when such flow is impeded because of viscosity and/or paraffin blockage conditions.

In satisfaction of these and related objects, the present invention provides a down hole heating system for use with oil and gas wells which exhibit less than optimally achievable flow rates because of high oil viscosity and/or blockage by paraffin (or similar meltable petroleum byproducts). The system of the present invention, and the method of use thereof, provides two primary benefits: (1) the involved heating unit is designed to overcome a previously unrecognized problem which leads to frequent failure of prior art heating units -- unit invasion by down hole heating units with resulting physical damage and/or electrical shortages; and (2) the system is designed to focus and contain heat in the production zone to promote flow to, and not just within, the production tubing.

### **BRIEF DESCRIPTION OF THE DRAWINGS**

Applicant's invention may be further understood from a description of the accompanying drawings, wherein unless otherwise specified, like referenced numerals are intended to depict like components in the various views.

Fig. 1 is an elevational view of a producing oil well with the components of the present down hole heating system installed.

Fig. 2 is a cross-section view of the heating unit connector of the preferred embodiment of the present invention.

Fig. 3 is a cross-section view of the heating unit connector of an alternative embodiment of the present invention.

Fig. 4 is a cross-section view of the heating unit connector of a second alternative embodiment of the present invention.

Fig. 5 is a cross-section view of the female segment of the heating unit connector of the second alternative embodiment of the present invention.

### **DETAILED DESCRIPTION OF THE PREFERRED EMBODIMENT**

Referring to figure 1, the complete down hole heating system of the present invention is generally identified by the reference numeral 10. System 10 includes production tubing 12 (the length of which depends, of course, on the depth of the well), a heat insulating packer 14, perforated tubing 16, a stainless steel tubing collar 18, and a heating unit 20.

Heat insulating packer 14 and stainless steel collars 18 are included in their stated form for "containing" the heat from heating unit 20 within the desired zone to the greatest practical degree. Were it not for these components, the heat from heating unit 20 would (like the heat from conventional down hole heater units) convect and conduct upward in the well bore and through the production tubing, thereby essentially directing much of the heat away from the area which it is most needed -- the production zone.

Perhaps, it goes without saying that oil that never reaches the pump will never be produced. However, this truism seems to have escaped designers of previous down-hole heating schemes, the use of which essentially heats oil only as it enters the production tubing, without effectively heating it so that it will reach the production tubing in the first place. Largely containing the heat below the level of the junction between the production tubing 12 and the perforated tubing 16, as is achieved through the current design, has the effect of focusing the heat on the production formation itself. This, in turn, heats oil and paraffin in situ and allows it to flow to the

well bore for pumping, thus "producing" first the viscous materials which are impeding flow, and then the desired product of the well (oil or gas). Stainless steel is chosen as the material for the juncture collars at and below the joiner of production tubing 12 and perforate tubing 16 because of its limited heat conductive properties.

Physical and chemical attack of the electrical connections between the power leads and the heater rods of conventional heating systems, as well as shorting of electrical circuits because of invasion of heater units by conductive fluids is another problem of the present art to which the present invention is addressed. Referring to Figure 2, the present inventor has discovered that, to prevent the aforementioned electrical problems, the internal connection for a down hole heating unit must be impenetrably shielded from the pressures and hostile chemical agents which surround the unit in the well bore.

The patent which serves as a priority basis for the present invention discloses an embodiment that tremendously increases down hole wiring connection integrity. However, referring to Figure 2, the present invention is even better at preventing the aforementioned problems. In fact, the unique combination of materials, particularly ceramic cement, a highly durable insulation means, and the use of connector pins, provides protection against shortage and other connection damage not previously possible. Such an improvement is of great significance as the internal connection for a down hole heating unit must be impenetrably shielded from the pressures and hostile chemical agents that surround the unit in the well bore.

Referring in combination to figure 1 and figure 2, heating unit 20 includes heating unit connector 30. Heating unit connector 30 is largely responsible for ensuring the integrity of the connection between surface wiring leads 24 and heater rod wiring leads 25. The electrical current for heater rod 26 is supplied by cable 22, which runs down the exterior of production tubing 12 and connects to surface wiring leads 24 at the upper end of heating unit 20.

As shown in Figure 2, heating unit connector 30 is comprised of two substantially identical pieces. The upper piece (nearest surface), generally designated by numeral 32, houses surface wiring leads 24. The lower piece (nearest downhole), generally designated by numeral 34, houses heater wiring 26.

Heater unit connector 30 also contains two connector pins (male and female),

wherein each connector pin has a distal and medial end. The union between male connector pins 40 and female connector pins 42 occurs about the medial end of each connector piece 40 and 42, and further about the medial portion of heater unit connector 30. Male connector pins 40, have female receptacles that receive male extensions from wiring leads 25. At its medial portion, male connector pins 40 have male extensions that may be plugged into the medial portion of female connector pins 42.

Female connector pins 42 contain female receptacles about both their medial and distal portions. At their distal portion, female connector pins 42 receive male extensions from surface wiring leads 24. At their medial portions, each female connector pin 42 receives a corresponding male connector pin 40. Importantly, the improvements provided by the present invention do not depend on any specific pin connector configuration. In fact, as will be apparent to those skilled in the art, different connector pin configurations or different pin types may work equally as well.

Connector pieces 32 and 34 each contain, in their distal portion, a high temperature ceramic-filled region, generally designated by numeral 36. The ceramic cement of region 36 serves to enclose the junction between each connector pin and the respective wiring of each piece. In the preferred embodiment, the high temperature ceramic cement is an epoxy material which is available as Sauereisen Cement #1, which may be obtained from the Industrial Engineering and Equipment Company ("INDEECO") of St. Louis, Missouri, U.S.A. However, as will be apparent to those skilled in the art, other materials may serve to perform the desired functions.

Upon drying, the high temperature ceramic cement of region 36 becomes an essentially glass-like substance. Shrinkage is associated with the cement as it dries. As such, in the preferred embodiment, each heater unit connector pieces contains a pipe plug 38. Pipe plug 38 provides an access point through which additional ceramic cement can be injected into each piece, thereby filling any void which develops as the ceramic cement dries. Further, pipe plug 38 may be reversibly sealed to each piece so that epoxy can be injected as needed while the strength of the seal is maintained.

Connector pieces 32 and 34 further contain, in their medial portion, an

insulator block region, designated by numeral 39. Insulator region 39 houses each connector pin so that the union between male connector pins 40 and female connector pins 42 is suitably insulated from any outside electrical or chemical agent.

In order to withstand the corrosive chemicals and enormous external pressure, the outer surface of heater unit connector 30 must be incredibly strong. The aforementioned elements of connector 30 are substantially encased in a fitting assembly 50, preferably made of steel ("encasement means"). Each component of assembly 50 is welded with continuous beads, preferably using the "TEG" welding process, to each adjoining component. The TEG welding process is preferred as it allows the seams of joined components to withstand extreme conditions in the well bore. Finally, in the preferred embodiment, the outer surface of connector 30 is comprised of stainless steel.

Each connector piece is secured to the other by fitting assembly 60. Fitting assembly 60 and sealing fitting 62 are, as would be apparent to those skilled in the art, designed to engage one another so as to form a sealed junction. In the preferred embodiment, this union is a standard two inch union that is modified by the "TEG" welding process mentioned above. That is, the union is welded using the TEG process so that it will withstand the extreme environmental condition of the well bore.

The shielding of the electrical connections between surface wiring leads 24 and heater wiring leads 25 is crucial for long-term operation of a down hole heating system of the present invention. Equally important is that power is reliably delivered to that connection. Therefore, solid copper leads with KAPTON insulation are used, such leads being of suitable gauge for carrying the intended 16.5 kilowatt, 480 volt, and associated current for the present system with its .475 inch diameter INCOLOY heater rods 26 (also available from INDEECO).

Referring to figures 3 and 4, an alternative embodiment of the present invention includes a heater assembly 112 connected to a surface assembly 114 by a connector assembly 116. In one alternative embodiment, connector assembly 116 sealably connects to heater assembly 112 via a welded connection as shown in figure 3. Alternatively, as shown in figure 4, connector assembly 116 is further characterized by a male connector pin section 118 and a female connector pin section

120. Male connector pin section 118 sealably connects to heater assembly 112 via a welded connection; however, female connector section 120 sealably connects to male connector section 118 via coupling ring 122. In the preferred embodiment, coupling ring 122 is made of aluminum bronze, but coupling ring 122 may also be made of other suitably corrosion resistant materials as known in the art. Referring to figures 3 and 5, in both embodiments, connector assembly 116 is further characterized in its connection to surface assembly 114 by pigtails 124 as generally known in the art. These pigtails are made by vulcanizing a connector portion directly to a length of cable. The pigtail is then spliced to the pump cable. In each alternative embodiment, the connection is further secured by a collar, as known in the art, at location 126.

The general connector arrangement, and other beneficial variations thereof, are known to be manufactured by KEMLON, of Pearland, Texas, U.S.A. These connectors produced at KEMLON are held out as being particularly effective as they can withstand enormous pressures and are known by those skilled in the art to be particularly effective in various hostile environments including subsurface oil wells and high temperature surroundings. Further, sound construction of these connectors makes for especially beneficial use. For instance, these components are made of excellent material, having an alloy steel, cadmium plated bod; a copper, gold plated contact; and KN-01 NEOPRENE standard insulation. In particular, connectors of the SL-5000 series, manufactured by KEMLON are thought to serve as particularly suitable components for the present system.

Various embodiments of the present invention include the method for use of the above-described system for heat treating an oil or gas well for improving well flow. The method includes use of a down hole heating unit with suitably shielded electrical connections substantially as described, along with installation of the heat-retaining elements also as described to properly focus heat on the producing formation.

In addition to the foregoing, it should be understood that the present method may also be utilized by substituting cable ("wire line") for the down hole pipe for supporting the heating unit 20 while pipe is pulled from the well bore. In other words, one can heat-treat a well using the presently disclosed apparatuses and their equivalents before re-inserting pipe, such as during other well treatments or

maintenance during which pipe is pulled. It is believed that this approach would be particularly beneficial in treating deep gas wells with an iron sulfide occlusion problem.

Although the invention has been described with reference to specific embodiments, this description is not meant to be construed in a limited sense. Various modifications of the disclosed embodiments, as well as alternative embodiments of the inventions will become apparent to persons skilled in the art upon the reference to the description of the invention. It is, therefore, contemplated that the appended claims will cover such modifications that fall within the scope of the invention.

**CLAIMS**

1. An apparatus for heating a segment of an oil and gas well bore and surrounding strata comprising:

an electrical resistance heating rod;

an electrical cable for carrying electrical current from an electrical current source outside of said well bore to said electrical resistance heating rod when positioned inside of said well bore;

an electrical lead having first and second lead ends, said first lead end being connected to said electrical cable, and said second lead end being attached to said heating rod;

a protective block in which is embedded the respective portions of said electrical lead and said heating rod as connect one to the other, said protective block being constructed of a moldable material which, when cured, is substantially impervious to pressure and chemical permeation and oil and gas well bore bottom pressures and environments;

a metallic encasement member encasing said protective block and sealingly connected to form a substantially impervious enclosure with said block and said embedded portion of said heating rod therein, except that said metallic encasement admits said electrical lead there into for attachment with said electrical lead;

a perforated production tubing segment with a proximal perforated production tubing segment end of which is reversibly engageable to a distal terminus of oil or gas well production tubing string and a distal perforated production tubing segment end of which is engageable with said metallic encasement member; and

a heating rod support frame which extends from said metallic encasement means opposite its engagement with said perforated production tubing segment and in which a portion of said heating rod is supported.

2. The apparatus of claim 1 further comprising a first and second connector pin, wherein said first pin and said second pin reversibly connect with one another, and by virtue of such connection, said first pin joins said electrical cable to said second pin and said second pin joins said heating rod to said first pin.

3. The apparatus of claim 2 wherein said protective block further comprises an insulated portion that substantially encloses said connection between said first pin and said second pin.

4. The apparatus of claim 3 where said metallic encasement member contains a reversibly sealable aperture through which said moldable material may be repeatedly injected to said block.

5. The apparatus of claim 1 wherein said metallic encasement member is sealingly connected via welding.

6. The apparatus of claim 5 wherein said metallic encasement member is welded together using a TEG welding process.

7. The apparatus of claim 1 wherein said metallic encasement member is sealingly connected via a coupling ring.

8. The apparatus of claim 1 where said metallic encasement member contains a reversibly sealable aperture through which said moldable material may be repeatedly injected to said block.

10. A method for enhancing production from an oil and gas well comprising the steps of:

selecting an apparatus for heating a segment of an oil and gas well bore and surrounding strata, said apparatus comprising:

an electrical resistance heating rod;

an electrical cable for carrying electrical current from an electrical current source outside of said well bore to said electrical resistance heating rod when positioned inside of said well bore;

an electrical lead having first and second lead ends, said first lead end being connected to said electrical cable, and said second lead end being attached to said heating rod;

a protective block in which is embedded the respective portions of said electrical lead and said heating rod as connect one to the other, said protective block being constructed of a moldable material which, when cured, is substantially impervious to pressure and chemical permeation and oil and gas well bore bottom pressures and environments;

a metallic encasement member encasing said protective block and sealingly connected to form a substantially impervious enclosure with said block and said embedded portion of said heating rod therein, except that said metallic encasement admits said electrical lead there into for attachment with said electrical lead;

a perforated production tubing segment with a proximal perforated production tubing segment end of which is reversibly engageable to a distal terminus of oil or gas well production tubing string and a distal perforated production tubing segment end of which is engageable with said metallic encasement member; and

a heating rod support frame which extends from said metallic encasement means opposite its engagement with said perforated production tubing segment and in which a portion of said heating rod is supported;

positioning said heating rod adjacent to a production zone in an oil or gas well bore, production from which zone is believed to be impeded by viscous materials;

attaching an electrical current source to said electrical cable; and

actuating said electrical current source to energize said heating rod and thereby heat said viscous materials in said production zone for reducing viscosity of said viscous materials for, in turn, producing said viscous materials.

11. The method of Claim 10 wherein said positioning of said heating rod adjacent to a production zone in an oil or gas well bore involves positioning said heating rod at a greater depth within said bore than said production zone to thereby allow heat from said heating rod to rise toward said production zone and said viscous materials situated therein.

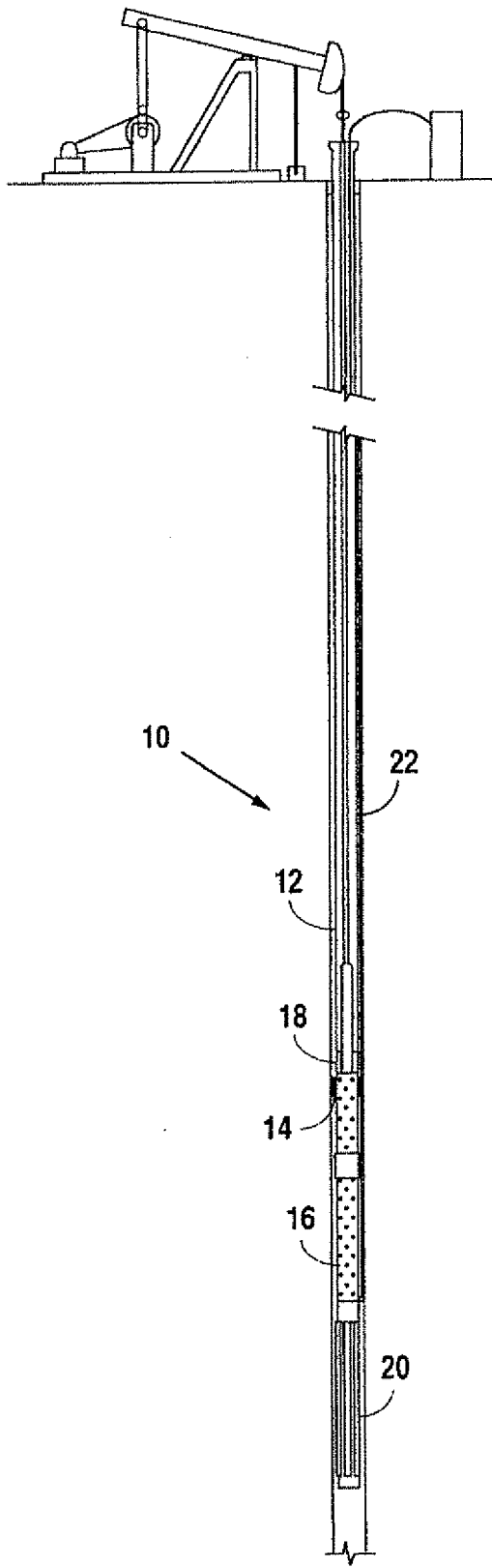
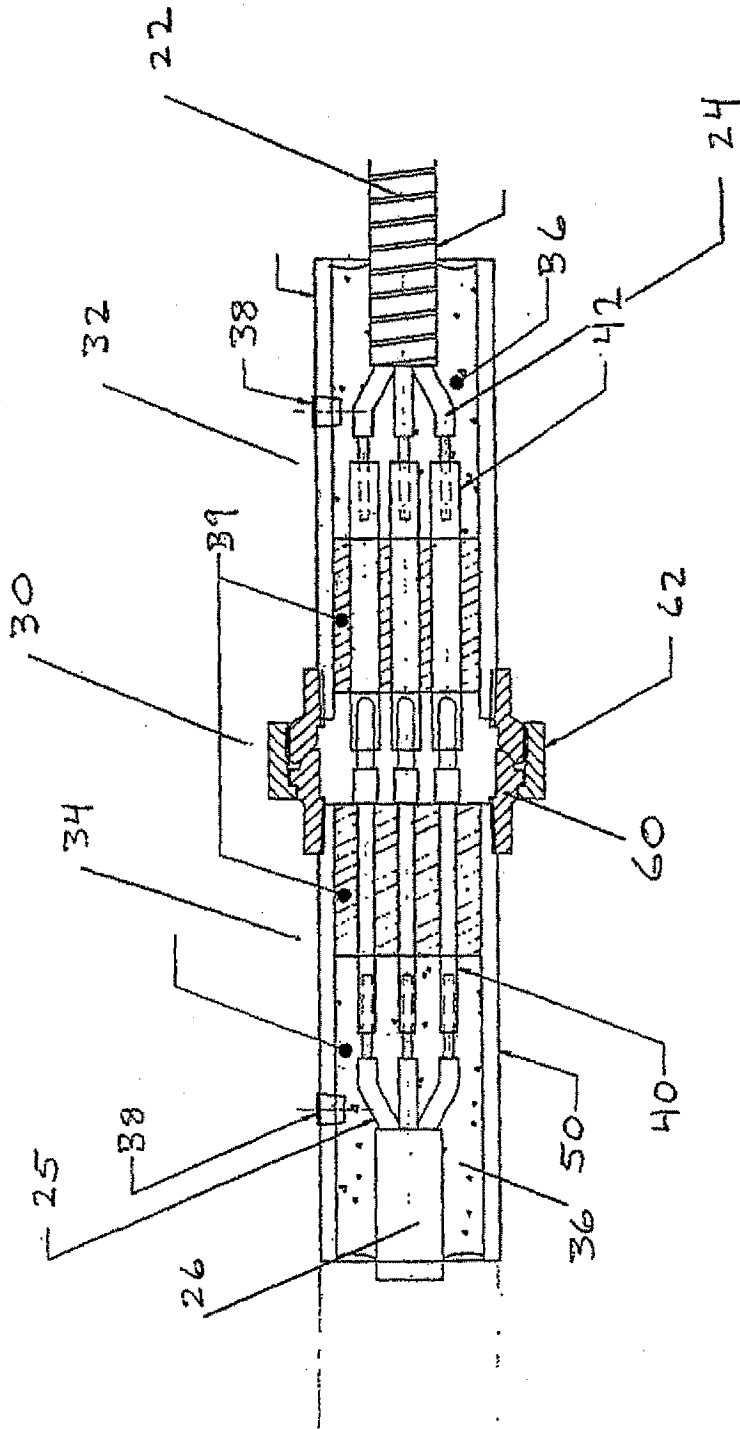

Fig. 1

Figure 2



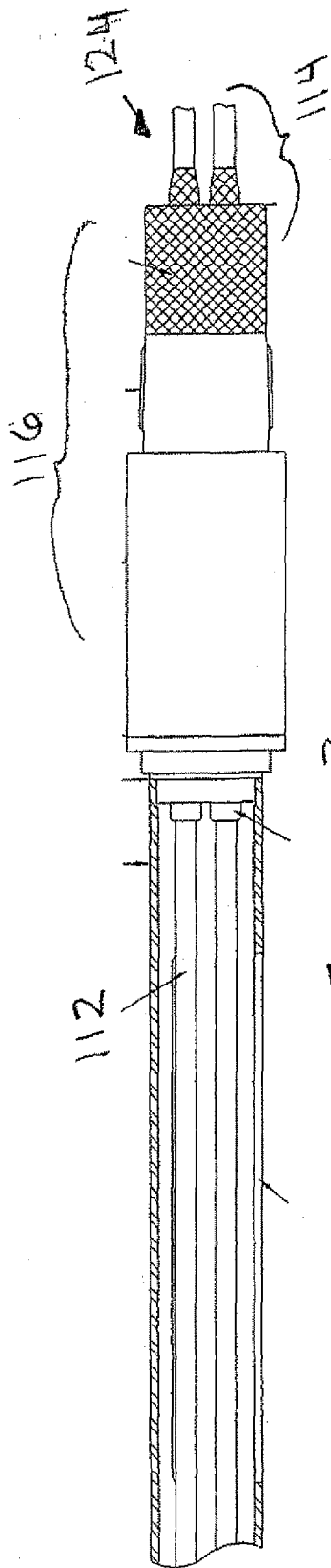

FIGURE 3

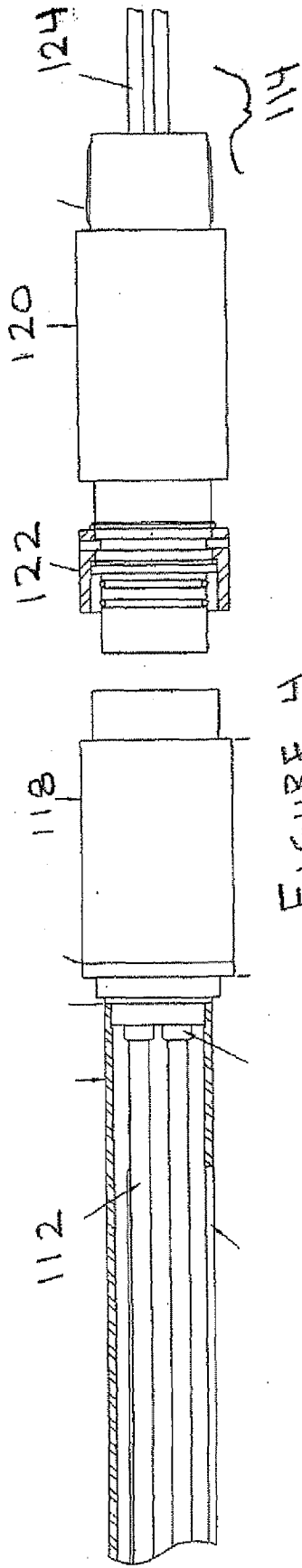

FIGURE 4

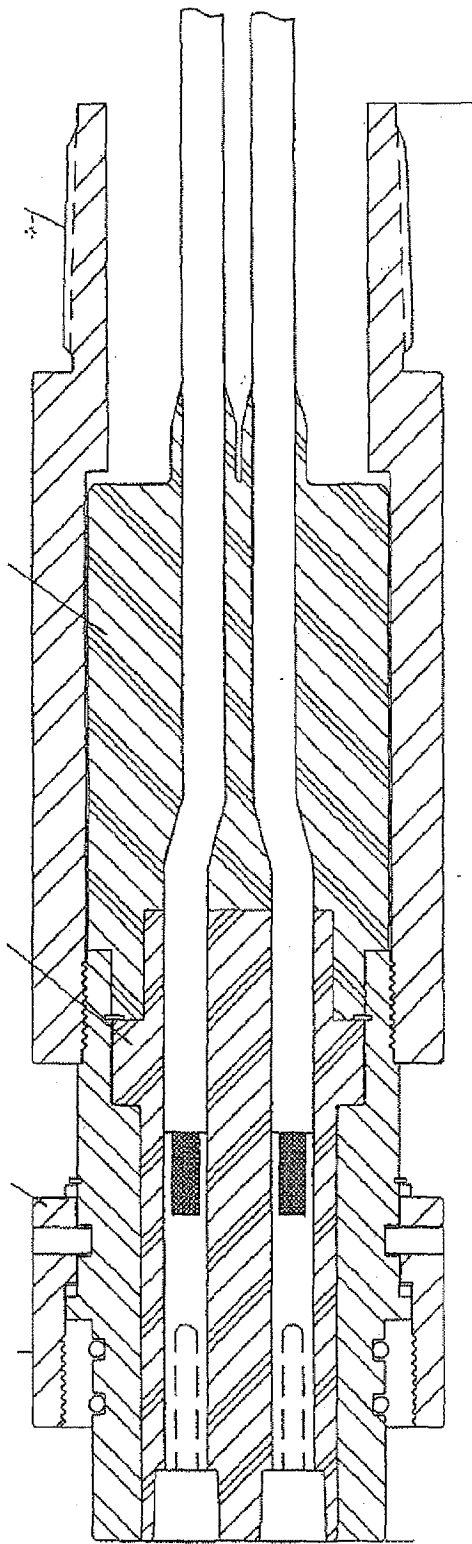

FIGURE 5