

(19) World Intellectual Property Organization
International Bureau



(43) International Publication Date
9 February 2006 (09.02.2006)

PCT

(10) International Publication Number
WO 2006/014131 A1

(51) International Patent Classification⁷: **A61C 13/00**

(21) International Application Number:
PCT/SE2005/001075

(22) International Filing Date: 4 July 2005 (04.07.2005)

(25) Filing Language: English

(26) Publication Language: English

(30) Priority Data:
0401985-7 5 August 2004 (05.08.2004) SE

(71) Applicant (for all designated States except US): **NOBEL BIOCARE AB (PUBL)** [SE/SE]; Box 5190, S-402 26 Göteborg (SE).

(72) Inventor; and

(75) Inventor/Applicant (for US only): **BRAJNOVIC, Izidor** [SE/SE]; Smörslottsgatan 4, S-416 77 Göteborg (SE).

(74) Agent: **OLSSON, Gunnar**; Nobel Biocare AB (publ), Box 5190, S-402 26 Göteborg (SE).

(81) Designated States (unless otherwise indicated, for every kind of national protection available): AE, AG, AL, AM, AT, AU, AZ, BA, BB, BG, BR, BW, BY, BZ, CA, CH, CN, CO, CR, CU, CZ, DE, DK, DM, DZ, EC, EE, EG, ES, FI, GB, GD, GE, GH, GM, HR, HU, ID, IL, IN, IS, JP, KE, KG, KM, KP, KR, KZ, LC, LK, LR, LS, LT, LU, LV, MA, MD, MG, MK, MN, MW, MX, MZ, NA, NG, NI, NO, NZ, OM, PG, PH, PL, PT, RO, RU, SC, SD, SE, SG, SK, SL, SM, SY, TJ, TM, TN, TR, TT, TZ, UA, UG, US, UZ, VC, VN, YU, ZA, ZM, ZW.

(84) Designated States (unless otherwise indicated, for every kind of regional protection available): ARIPO (BW, GH, GM, KE, LS, MW, MZ, NA, SD, SL, SZ, TZ, UG, ZM, ZW), Eurasian (AM, AZ, BY, KG, KZ, MD, RU, TJ, TM), European (AT, BE, BG, CH, CY, CZ, DE, DK, EE, ES, FI, FR, GB, GR, HU, IE, IS, IT, LT, LU, LV, MC, NL, PL, PT, RO, SE, SI, SK, TR), OAPI (BF, BJ, CF, CG, CI, CM, GA, GN, GQ, GW, ML, MR, NE, SN, TD, TG).

Published:

— with international search report

For two-letter codes and other abbreviations, refer to the "Guidance Notes on Codes and Abbreviations" appearing at the beginning of each regular issue of the PCT Gazette.

(54) Title: DEVICE AND PROCEDURE FOR FACILITATING THE FITTING OF A TOOTH OR TOOTH REMNANT TEMPLATE INTO THE RIGHT POSITION

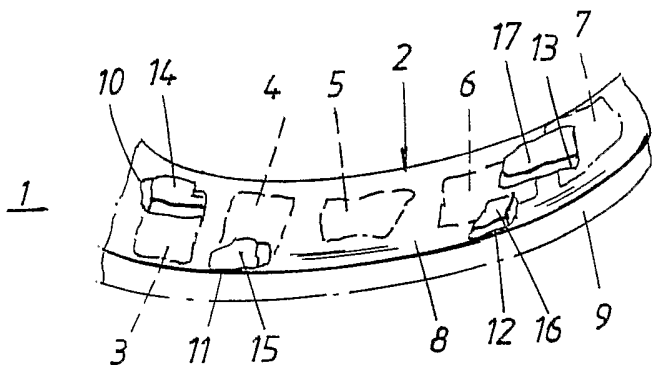

(57) Abstract: In a device for facilitating the fitting into the right position of a template intended for real teeth and/or tooth remnants the construction of the template is related to the shape of the affected teeth and/or tooth remnant parts which is obtained from simulation equipment, e.g. plaster model, computer, etc. The template is arranged with recesses, at which characteristic parts of the shape emerge. When the template is fitted to the real teeth and/or tooth remnant parts, the right position arises when the characteristic parts of the real teeth and/or tooth remnant parts correspondingly emerge through the recesses and form a visual indication of the right position. The invention also relates to a procedure. The invention provides the possibility, firstly, that a right position for the template

can be attained with the visual indication given by the characteristic parts, and, secondly, that a home-in function is obtained for the template when it is fitted.



WO 2006/014131 A1

Device and procedure for facilitating the fitting of a tooth or tooth remnant template into the right position.

- 5 The present invention relates to a device and procedure for facilitating the fitting into the right position of a template intended for real teeth and/or tooth remnants.
- 10 Templates of this kind are used in dental work and are placed into the patient's oral cavity at the affected place on or near teeth/tooth remnants and spaces near the latter. The template can include guide sleeves, with which drills and other instruments are guided,
15 e.g. at the hole uptake for an implant. It should be possible to use the template in a distinct way, irrespective of the position in the patient's oral cavity. There are cases, however, where fitting is difficult to carry out, which can lead to the template
20 ending up in the wrong position. There is thus a need for being able to attain a distinct fitting position for the template and obtain an indication about this. The present invention solves this problem.
- 25 What can mainly be regarded as characterizing for a device according to the invention is *inter alia* the fact that the construction of the template is related to the shape of the affected teeth and/or tooth remnant parts which is obtained from simulation equipment, e.g.
30 plaster model, computer, etc. The template can furthermore be arranged with openings or recesses, at which characteristic parts of the shape emerge. When the template is fitted to the real teeth and/or tooth remnant parts, the right position arises when the
35 characteristic parts of the real teeth and/or tooth remnant parts correspondingly emerge through the openings or recesses and form a visual indication of said right position. A home-in function for the

template also arises.

Further developments of the inventive idea for the new device are apparent from the appended claims.

5

A procedure according to the invention is characterized *inter alia* by the fact that a model and/or image of the real teeth and/or tooth remnant parts is produced by means of modelling and/or imaging equipment and that
10 the template is produced with the aid of the model or image, as the case may be. The template is furthermore provided with openings or recesses at characteristic parts, e.g. projecting and/or protruding parts, of those parts of the teeth and/or tooth remnant parts
15 which are reproduced by the model or image, as the case may be. The template can finally be fitted to the real teeth and/or tooth remnant parts, which characteristic parts emerging through the openings or recesses give a visual indication of the right position.

20

Further developments of the inventive idea for the new procedure are apparent from the appended claims.

Through what is proposed above, distinct positions can
25 easily be attained for the template. The visual indication eliminates the need for special equipment for determining the right final position for the template. Conventional production techniques can be used for the template, which only needs to be provided
30 with the recesses, preferably in its upper parts.

The device and procedure proposed at present will be described below with simultaneous reference to the appended drawing, where

35

Figure 1 shows in perspective a template fitted to a plaster model of the patient's oral cavity,

- 3 -

Figure 2 shows the position of the template on an image, in outline diagram form, and

5 Figure 3 shows templates according to Figures 1 and 2, and the placing thereof in the patient's oral cavity, in perspective.

In Figure 1 parts of a plaster model of the patient's oral cavity are indicated as 2. The plaster model
10 indicates teeth and/or tooth remnant parts 3, 4, 5, 6 and 7. On said teeth and/or parts a template is fitted, e.g. a surgical template, which is constructed with sleeves or guide members, not specifically shown, for a drill, not shown, by means of which a hole uptake will
15 be made in a mandible 9 in a known manner. In its upper parts the template is provided with through recesses 10, 11, 12 and 13. Characteristic parts 14, 15, 16 and 17 from the teeth and/or the tooth remnant parts emerge through these. The template can be manufactured in a
20 known manner.

In Figure 2 an image 18 is generated on a computer/computer screen 19. In this case the template is denoted as 20 and the mandible is denoted as 21. In
25 its upper surface the template is provided with three through recesses 22, 23 and 24, in which characteristic parts 25, 26 and 27 emerge (cf. Figure 1). The teeth and/or the tooth remnant parts are not shown in this case. The production of the image can be effected with
30 known software. The template can be manufactured in accordance with information from the computer in a known manner.

As shown in Figure 3 the finished templates 28 and 29
35 will be fitted in the oral cavity 30 of a patient. The characteristic parts 14, 15, 16 and 17, or 25, 26 and 27, as the case may be, will emerge in the same way through the recesses 10, 11, 12 and 13, or 22, 23 and

24, in the corresponding template. The corresponding
templates 28 and 29 are given a facilitated home-in
function with the characteristic parts which in
addition give a visual indication of the fact that the
5 position homed in on is right, by comparing with a
model, image, etc.

The invention is not limited to the embodiments
indicated but can be subject to modifications within
10 the scope of the following claims and the inventive
idea.

CLAIMS

1. Device for facilitating the fitting into the right position of a template intended for real teeth and/or tooth remnants, characterized in that the construction of the template is related to the shape of the affected teeth and/or tooth remnant parts which is obtained from simulation equipment, e.g. plaster model, computer, etc., that the template is arranged with openings or recesses, at which characteristic parts of the shape emerge, and that when the template is fitted to the real teeth and/or tooth remnant parts, the right position arises when the characteristic parts of the real teeth and/or tooth remnant parts correspondingly emerge through the openings or recesses and form a visual indication of the right position.

2. Device as claimed in Claim 1, characterized in that the number of recesses and characteristic parts is three or more in number.

3. Device as claimed in Claim 1 or 2, characterized in that the number of recesses and characteristic parts is four in number.

4. Device as claimed in Claim 1, 2 or 3, characterized in that the recesses are arranged mainly on the top or upper parts of the template.

5. Device as claimed in any of Claims 1-4, characterized in that the position of the template on the model or in the image is comparable with the position of the template on the real teeth and/or tooth remnant parts.

6. Procedure to facilitate the fitting into the right position of a template intended for real teeth and/or tooth remnant parts, characterized in that a model

and/or image of the real teeth and/or tooth remnant parts is produced by means of modelling and/or imaging equipment, that the template is produced with the aid of the model or image, as the case may be, that the
5 template is provided with openings or recesses at characteristic parts, e.g. projecting and/or protruding parts, of those parts of the teeth and/or tooth remnant parts which are reproduced by the model or image, as the case may be, and that the template is fitted to the
10 real teeth and/or tooth remnant parts, which characteristic parts emerging through the openings or recesses give a visual indication of the right position.

15 7. Procedure as claimed in Claim 6, characterized in that the template is constructed with three or more recesses for a corresponding number of characteristic parts.

20 8. Procedure as claimed in Claim 6 or 7, characterized in that the position of the template on the real teeth and/or tooth remnant parts is compared with the position of the template on the model or in the image, as the case may be.

25 9. Procedure as claimed in Claim 6, 7 or 8, characterized in that the template is constructed with the recesses on its upper parts or top.

30 10. Procedure as claimed in any of Claims 6-9, characterized in that the template is given a home-in function during fitting by means of interactions between the recesses of the template and the characteristic parts.

1/1

Fig. 1

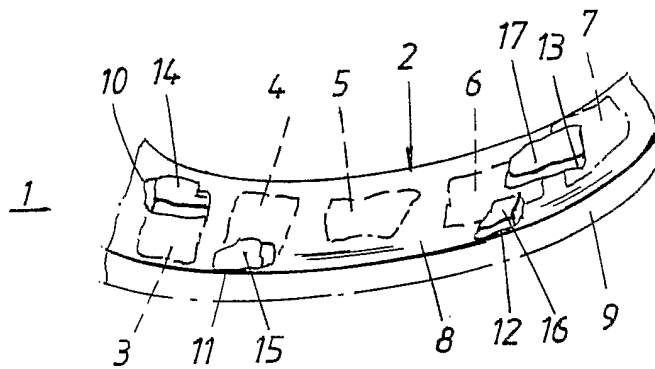

Fig. 2

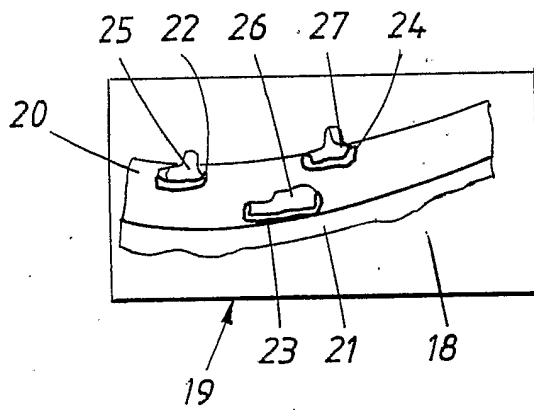
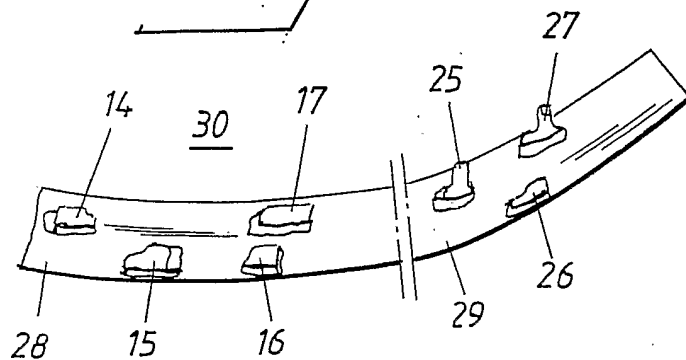

Fig. 3



INTERNATIONAL SEARCH REPORT

International application No.
PCT/SE 2005/001075

A. CLASSIFICATION OF SUBJECT MATTER

IPC7: A61C 13/00
According to International Patent Classification (IPC) or to both national classification and IPC

B. FIELDS SEARCHED

Minimum documentation searched (classification system followed by classification symbols)

IPC7: A61C

Documentation searched other than minimum documentation to the extent that such documents are included in the fields searched

SE,DK,FI,NO classes as above

Electronic data base consulted during the international search (name of data base and, where practicable, search terms used)

EPO-INTERNAL, WPI DATA, PAJ

C. DOCUMENTS CONSIDERED TO BE RELEVANT

Category*	Citation of document, with indication, where appropriate, of the relevant passages	Relevant to claim No.
A	GB 1131948 A (JOE JOHN SIMMONS), 30 October 1968 (30.10.1968), figure 1b --	1-10
A	US 4470815 A1 (MITCHELL M. HAZAR), 11 Sept 1984 (11.09.1984), figures 5-7, abstract ---	1-10
A	US 6227861 B1 (RICHARD G. CARTLEDGE ET AL), 8 May 2001 (08.05.2001), figure 7 --	1-10
A	US 20020106604 A1 (LOC X. PHAN ET AL), 8 August 2002 (08.08.2002), figure 7 -- -----	1-10

Further documents are listed in the continuation of Box C. See patent family annex.

<p>* Special categories of cited documents:</p> <p>"A" document defining the general state of the art which is not considered to be of particular relevance</p> <p>"E" earlier application or patent but published on or after the international filing date</p> <p>"L" document which may throw doubts on priority claim(s) or which is cited to establish the publication date of another citation or other special reason (as specified)</p> <p>"O" document referring to an oral disclosure, use, exhibition or other means</p> <p>"P" document published prior to the international filing date but later than the priority date claimed</p>	<p>"T" later document published after the international filing date or priority date and not in conflict with the application but cited to understand the principle or theory underlying the invention</p> <p>"X" document of particular relevance: the claimed invention cannot be considered novel or cannot be considered to involve an inventive step when the document is taken alone</p> <p>"Y" document of particular relevance: the claimed invention cannot be considered to involve an inventive step when the document is combined with one or more other such documents, such combination being obvious to a person skilled in the art</p> <p>"&" document member of the same patent family</p>
---	---

Date of the actual completion of the international search 1 November 2005	Date of mailing of the international search report 02-11-2005
---	---

Name and mailing address of the ISA/ Swedish Patent Office Box 5055, S-102 42 STOCKHOLM Facsimile No. +46 8 666 02 86	Authorized officer Leif Brander/MP Telephone No. +46 8 782 25 00
--	---

INTERNATIONAL SEARCH REPORT

Information on patent family members

01/10/2005

International application No.

PCT/SE 2005/001075

GB	1131948	A	30/10/1968	NONE		
US	4470815	A1	11/09/1984	US	4583947 A	22/04/1986
US	6227861	B1	08/05/2001	WO	02069831 A	12/09/2002

INTERNATIONAL SEARCH REPORT

Information on patent family members

01/10/2005

International application No.

PCT/SE 2005/001075

US	20020106604	A1	08/08/2002	US	6705863	B	16/03/2004
				US	20040048223	A	11/03/2004
				US	20040229183	A	18/11/2004
				AT	249178	T	15/09/2003
				AU	726743	B	16/11/2000
				AU	779176	B	13/01/2005
				AU	8156498	A	04/01/1999
				AU	2005201222	A	00/00/0000
				BR	9810051	A	12/09/2000
				CA	2292533	A	30/12/1998
				DE	69818045	D,T	03/06/2004
				DK	989828	T	15/12/2003
				EP	0989828	A,B	05/04/2000
				SE	0989828	T3	
				IL	133343	D	00/00/0000
				IL	158144	D	00/00/0000
				JP	3620048	B	16/02/2005
				JP	2002514125	T	14/05/2002
				US	6309215	B	30/10/2001
				US	6398548	B	04/06/2002
				US	6409504	B	25/06/2002
				US	6450807	B	17/09/2002
				US	6554611	B	29/04/2003
				US	6682346	B	27/01/2004
				US	6722880	B	20/04/2004
				US	20020037489	A	28/03/2002
				US	20020064747	A	30/05/2002
				US	20020150855	A	17/10/2002
				US	20030003416	A	02/01/2003
				US	20030008259	A	09/01/2003
				US	20030039389	A	27/02/2003
				US	20040110110	A	10/06/2004
				CN	1260698	A,T	19/07/2000
				EP	1369091	A	10/12/2003
				ES	2206952	T	16/05/2004
				JP	2004243141	A	02/09/2004
				JP	2004255205	A	16/09/2004
				JP	2004267790	A	30/09/2004
				JP	2005021714	A	27/01/2005
				PT	989828	T	27/02/2004
				TW	396034	B	01/07/2000
				US	5975893	A	02/11/1999
				US	6217325	B	17/04/2001
				US	6471511	B	29/10/2002
				US	6626666	B	30/09/2003
				US	6629840	B	07/10/2003
				US	6699037	B	02/03/2004
				US	20010006770	A	05/07/2001
				US	20010008751	A	19/07/2001
				US	20010009753	A	26/07/2001
				US	20040166456	A	26/08/2004
				WO	9858596	A	30/12/1998
				AU	1634700	A	19/06/2000
				AU	3104600	A	19/06/2000
				CA	2351420	A	08/06/2000

INTERNATIONAL SEARCH REPORT

Information on patent family members

01/10/2005

International application No.

PCT/SE 2005/001075

US	20020106604	A1	08/08/2002	CA	2351513	A	08/06/2000
				EP	1143872	A	17/10/2001
				EP	1146832	A	24/10/2001
				JP	3636661	B	06/04/2005
				JP	3636662	B	06/04/2005
				JP	2002531166	T	24/09/2002
				JP	2002531167	T	24/09/2002
				JP	2005118592	A	12/05/2005
				JP	2005161048	A	23/06/2005
				JP	2005161049	A	23/06/2005
				US	6183248	B	06/02/2001
				US	6390812	B	21/05/2002
				US	6485298	B	26/11/2002
				US	6705861	B	16/03/2004
				US	20020051951	A	02/05/2002
				US	20020142258	A	03/10/2002
				US	20030186184	A	02/10/2003
				US	20040209218	A	21/10/2004
				WO	0032131	A	08/06/2000
				WO	0032132	A	08/06/2000
				AU	1108000	A	26/04/2000
				AU	1444100	A	26/04/2000
				AU	6420399	A	26/04/2000
				CA	2346255	A	13/04/2000
				EP	1119308	A	01/08/2001
				JP	3636660	B	06/04/2005
				JP	2002526153	T	20/08/2002
				JP	2005144190	A	09/06/2005
				TW	476634	B	21/02/2002
				TW	480166	B	00/00/0000
				TW	514517	B	00/00/0000
				US	6802713	B	12/10/2004
				US	20050079468	A	14/04/2005
				WO	0019928	A	13/04/2000
				WO	0019930	A	13/04/2000
				WO	0019931	A	13/04/2000
				US	6145248	A	14/11/2000
				US	6691455	B	17/02/2004
				US	6210162	B	03/04/2001
				ZA	9805379	A	19/04/1999
				US	20030064345	A	03/04/2003