

R. S. MERRILL.

Car Lamp.

No. 109,537.

Patented Nov. 22, 1870.

Fig. 1.

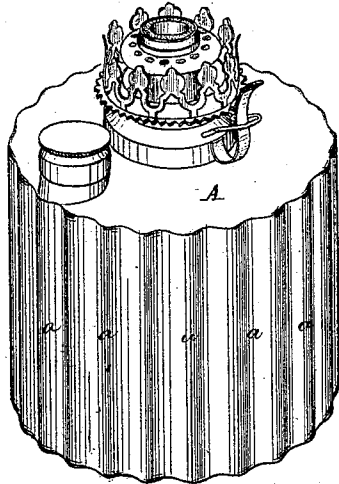
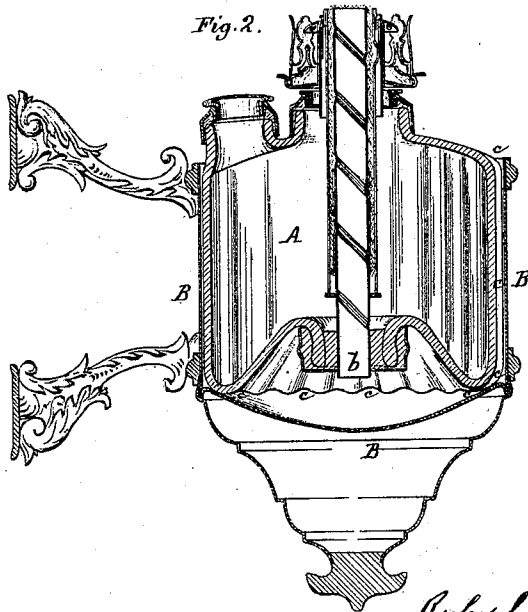

Fig. 2.



Witnesses.

W. B. Bailey
John Buckley

Rufus S. Merrill
by his attorney
A. Rollis

United States Patent Office.

RUFUS S. MERRILL, OF BOSTON, MASSACHUSETTS, ASSIGNOR TO HIMSELF,
JOSHUA MERRILL, AND WILLIAM B. MERRILL, OF SAME PLACE.

Letters Patent No. 109,537, dated November 22, 1870.

IMPROVEMENT IN LAMPS FOR RAILROAD-CARS.

The Schedule referred to in these Letters Patent and making part of the same.

To whom it may concern :

Be it known that I, RUFUS S. MERRILL, of Boston, in the county of Suffolk and State of Massachusetts, have invented certain new and useful Improvements in Lamps for Railroad Cars, and other purposes, of which the following is a specification.

My invention relates to argand lamps, having an aperture in the lower part of the lamp-body for the admission of the air, which forms the central draught; and

Its object is to adapt lamps of this kind for use with the ordinary cylindrical lamp-holders or brackets now generally in use in railroad-cars and other places.

The holders or brackets referred to consists of a cylindrical body or cup, into which the body or oil-reservoir of the lamp is tightly fitted, so that it may not rattle or be shaken about in the bracket when the cars are in motion.

If, however, the body of the lamp is a plain cylinder, so as to fit against the sides of the holder, little or no air can pass down between the sides of the lamp and the holder to create and keep up with regularity the central draught.

Therefore, in applying an argand lamp to a holder, such as referred to, it is necessary to provide, not only that it shall fit tightly in the holder, but also that space may be left leading from the upper to the lower part of the lamp-body, through which air may pass to the central draught-passage of the lamp.

To accomplish this result is the object of my invention, which consists in forming a series of corrugations or depressions upon the exterior of the body of an argand lamp in such manner that when the lamp is placed and fitted in the holder, air-passages will be formed by said corrugations or depressions, leading from the upper part of the lamp to the lower part, or bottom, where the mouth of the central draught-passage is located, thus supplying the burner with the requisite amount of air without preventing in any way the lamp-body from fitting tightly within the holder.

The manner in which my invention is or may be carried into effect will be readily understood by reference to the accompanying drawing, in which—

Figure 1 is a perspective view of an argand lamp, made in accordance with my invention.

Figure 2 is a vertical section of the same, together with the lamp-bracket or holder in which it is placed.

The body of the lamp may be made of glass or metal, and it is of such size and shape as to fit snugly within the holder to which it is to be applied.

In the present case its general contour is cylindrical, but a series of corrugations, *a*, are formed

upon its exterior, which extend from its upper part to its base, so that when the sides and bottom of the lamp come in contact with the cylindrical but smooth or plane surface of the holder, a series of passages will be formed, which will admit air to the central draught-passage of the lamp, no matter how tightly the lamp-body and the holder are fitted together.

This is shown in fig. 2, where;

A represents the lamp-body;

B, the holder, of ordinary construction;

b, the lower opening or mouth of the central draught-tube; and

c, one of the air-passages between the sides of the lamp and the holder.

In the present instance, the corrugations extend a slight distance under the bottom, so as to conduct the air to the opening *b*; but, instead of this, knobs, or like devices, may be formed on or applied to the bottom of the lamp for a like purpose.

The bottom of the lamp, at its periphery, extends below the central part, where the mouth *b* is located, so that the lamp-body may rest upon a flat surface with perfect steadiness, at the same time that air passes without hindrance under the bottom to the central draught-tube.

The chief advantage, however, of my invention is that it allows an argand lamp to be applied to and used with lamp-holders or brackets of ordinary construction without necessitating the least alteration or change in the same.

In lieu of corrugating the exterior of the lamps, studs or knobs may be formed thereon, or the body may be otherwise constructed, so as to fit closely within the holder, and yet leave passages for the admission of air to the central draught-tube.

Having now described my invention, and the manner in which the same is or may be carried into effect,

What I claim, and desire to secure by Letters Patent, is—

The combination, with a lamp-holder or bracket, constructed so as to inclose the oil-vessel, as described, of an argand lamp, fitting in the said holder, and corrugated or otherwise formed upon its exterior, as specified, so that under all circumstances no matter how closely the lamp may fit within the holder, spaces will be left between the holder and lamp-body for the passage of air to the central draught-tube, substantially as shown and set forth.

In testimony whereof, I have signed my name to this specification, before two subscribing witnesses.

RUFUS S. MERRILL.

Witnesses:

M. BAILEY,

EDM. F. BROWN.