

(12) PATENT
(19) AUSTRALIAN PATENT OFFICE

(11) Application No. AU 199670251 B2
(10) Patent No. 702010

(54) Title
Surgical cassette loading and unloading system

(51)⁶ International Patent Classification(s)
A61M 001/00

(21) Application No: **199670251** (22) Application Date: **1996 .10 .16**

(30) Priority Data

(31) Number	(32) Date	(33) Country
08/559016	1995 .11 .15	US

(43) Publication Date : **1997 .05 .22**

(43) Publication Journal Date : **1997 .05 .22**

(44) Accepted Journal Date : **1999 .02 .11**

(71) Applicant(s)
Alcon Laboratories, Inc.

(72) Inventor(s)
Richard L. Zaleski II

(74) Agent/Attorney
PHILLIPS ORMONDE FITZPATRICK

(56) Related Art
US 5387088
WO 83/03121



AU9670251

(12) PATENT ABSTRACT (11) Document No. AU-A-70251/96
(19) AUSTRALIAN PATENT OFFICE

(54) Title
SURGICAL CASSETTE LOADING AND UNLOADING SYSTEM

International Patent Classification(s)
(51)⁶ **A61M 001/00**

(21) Application No. : **70251/96** (22) Application Date : **16/10/96**

(30) Priority Data

(31) Number	(32) Date	(33) Country
559016	15/11/96	US UNITED STATES OF AMERICA

(43) Publication Date : **22/05/97**

(71) Applicant(s)
ALCON LABORATORIES, INC.

(72) Inventor(s)
RICHARD L. ZALESKI II

(74) Attorney or Agent
PHILLIPS ORMONDE & FITZPATRICK , 367 Collins Street, MELBOURNE VIC 3000

(57) A surgical cassette unloading and unloading system having a peristaltic pump roller head with a flared and beveled notch and a plunger or probe that engages the cassette peristaltic pump tube.

Abstract of the Disclosure

A surgical cassette unloading and unloading system having a peristaltic pump roller head with a flared and beveled notch and a plunger or probe that engages the cassette peristaltic pump tube.

5
2
6
3
4

SURGICAL CASSETTE LOADING AND UNLOADING SYSTEMBackground of the Invention

The present invention relates to surgical cassettes and more particularly to a system for loading and unloading surgical cassettes.

5 The use of cassettes with surgical instruments to help manage irrigation and aspiration flows into a surgical site are well-known. U.S. Patent Nos. 4,493,695, 4,627,833 (Cook), 4,395,258 (Wang, et al.), 4,713,051 (Steppe, et al.), 4,798,850 (DeMeo, et al.), 4,758,238, 4,790,816 (Sundblom, et al.) and 5,267,956, 5,364,342 (Beuchat) all disclose tubeless or tube-type surgical cassettes and are incorporated herein in their
10 entirety by reference.

One of the primary function of the cassettes disclosed above is to control aspiration (vacuum) level at the surgical site. The vacuum generating device generally is contained within the surgical system control console and may be a venturi, diaphragm or peristaltic pump. When a peristaltic pump is used, the cassette generally contains a peristaltic pump tube that may be compressed within a race by a rotating pump roller head (e.g. U.S. Patent No. 4,713,051, Steppe, et al.) or may be stretched over the rotating pump roller head (e.g. U.S. Patent Nos. 5,267,956 and 5,364,342, Beuchat). When the pump tube is stretched over the roller head, it may be difficult not only to install the pump tube over the roller head, but also to remove the pump tube from the roller head. The operation of peristaltic pump roller heads, and particularly peristaltic pump roller heads used in ophthalmic instruments, is more fully disclosed in U.S. Patent Nos. 5,230,614 (Zanger, et al.), and 5,387,088 (Knapp, et al.), the contents of which are incorporated herein by reference.

25 Accordingly, a need exists for a system to assist in loading and unloading a surgical cassette.

Brief Description of the Invention

According to an aspect of the present invention there is provided a system for loading and unloading a surgical cassette having a peristaltic pump tube from a cassette receiving portion of a surgical console, including:

(a) a peristaltic pump roller head located in the cassette receiving portion of the surgical console, the roller head having a body member and a plurality of rollers connected therewith for engaging the pump tube, the roller head body member including a notch for guiding the tube onto and off the rollers during loading and unloading of the cassette, respectively; and

(b) an extendable cylinder within the cassette receiving portion of the surgical console aligned to engage the peristaltic pump tube and adapted to assist in guiding the tube off the rollers of the roller head during unloading of the surgical cassette.

In a preferred embodiment of the invention the notch includes a flared portion and a bevelled portion for use in guiding the peristaltic pump tube onto and off the rollers during loading and unloading of the surgical cassette, respectively. Desirably, the bevelled portion of the notch is located at a leading edge region of the notch and the flared portion is located at a trailing edge region of the notch, the leading edge region and the trailing edge region of the notch being in relation to direction of roller head rotation for loading of the surgical cassette.

In a preferred embodiment of the invention the body member of the roller head includes a first disc-shaped element having the plurality of rollers extending therefrom and spaced therearound. The notch is located in a periphery of the first disc element between adjacent rollers. Preferably, the disc element has an outer side and an inner side, with the plurality of rollers extending inwardly from the inner side of the disc. The flared portion typically projects outwardly of the outer side and the bevelled portion is typically angled inwardly of the outer side.

According to another aspect of the present invention there is provided a surgical console including:

(a) a peristaltic pump roller head having a body member and a plurality of rollers connected therewith for engaging a peristaltic pump tube, the

roller head body member including a notch for guiding the tube both onto and off the rollers during loading and unloading of the cassette, respectively;

(b) a removable cassette having a peristaltic pump tube stretched over the peristaltic pump roller head; and

5 (c) an extendable cylinder aligned to engage the peristaltic pump tube and adapted to assist in guiding the tube off the rollers of the roller head during unloading of the surgical cassette.

10 From the above, therefore, in at least one form the invention includes a peristaltic pump roller head with a flared and bevelled notch in combination with a plunger or probe that engages the cassette peristaltic pump tube. When the cassette is installed in the console, the roller head is rotated so that the flared notch of the roller head engages the tube and pulls the tube over the roller head. When the cassette is removed from the console, the roller head is counter-rotated while the plunger telescopes to push the pump tube away from the roller head. The counter-rotation of the roller head together with the bevel on the roller head and the action of the plunger disengages the pump tube from the roller head.



Preferred embodiments of the present invention are able to provide numerous advantages. For example, the invention may provide:

- 20 - a system for simplifying the loading and unloading of surgical cassettes;
- a system for loading a peristaltic pump tube onto a peristaltic pump roller head; and
- a system for unloading a peristaltic pump tube from a peristaltic pump roller head.



The above and other features and advantages of the present invention will become more apparent from the following detailed description of the invention with reference to the accompanying drawings.

30 Brief Description of the Drawings

Fig. 1 is an exploded perspective view of the present invention.



Fig. 2 is an exploded perspective view of the present invention, similar to Fig. 1 but depicting the peristaltic pump tube engaged on the peristaltic pump roller head.

Fig. 3 is a partial elevational view of the present invention depicting the peristaltic pump tube engaged on the peristaltic pump roller head.

Fig. 4 is a cross-sectional view of the present invention taken along line 4-4 in Fig. 3.

Fig. 5 is a cross-sectional view of the present invention taken along line 5-5 in Fig. 3.

10

Detailed Description of the Invention

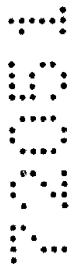

15

As best seen in Figs. 1 and 2, system 10 of the present invention generally consists of roller head 12 and plunger assembly 14. Roller head 12 generally consists of inner plate 16 and outer plate 18 joined by a plurality of rollers 20. Outer plate 18 contains notch 22 and, as best seen in Fig. 4, outer plate 18 has flared portion 24 and



beveled portion 40, both bordering notch 22. Notch 22, flared portion 24 and beveled portion 40 operate to assist in the loading and unloading of peristaltic pump tube 26 in the manner described below.

Plunger assembly 14 generally consists of cylinder 28 and tip 30. Cylinder 28 may be any of a variety of electrically or hydraulically extendable cylinders, but a pneumatic cylinder with a power generation range of between 4.0 pound-feet and 5.0 pound-feet, and an extension range of between 0 inches and 0.4 inches is preferred. Suitable cylinders 28 are commercially available from sources such as American Cylinder Company, Inc. Tip 30 preferably is approximately 1 inch long and made from aluminum or an aluminum alloy. As can be seen in FIGS. 1, 2 and 5, tip 30 contains an arcuate cutout 32 of approximately the same radius as pump tube 26 (e.g., 0.125 inches) so that tip 30 engages pump tube 26 without slipping off.

In use, cassette 34 containing pump tube 26 is installed within cassette receiving portion 36 of surgical console 38 so that pump tube 26 is pressed against outer plate 18 of roller head 12. In order to provide peristaltic pumping action, pump tube 26 must be stretched over rollers 20 contained in roller head 12. To assist in this process, flared portion 24 of outer plate 18 projects out from outer plate 18. As roller head 12 is rotated, flared portion 24 engages pump tube 26, thereby threading pump tube 26 over rollers 20.

To disengage pump tube 26 from rollers 20, cylinder 28 is extended so that arcuate cutout 32 on tip 30 engages pump tube 26 (as seen in FIGS. 3, 4 and 5). Further extension of cylinder 28 pushes pump tube 26 away from cassette receiving portion 36 of console 38. When roller head 12 is counter-rotated, flared portion 24 and beveled portion 40 of outer plate 18 unthreads pump tube 26 from rollers 20.

This description is given for purposes of illustration and explanation. It will be apparent to those skilled in the relevant art that changes and modifications may be made to the invention described above without departing from its scope or spirit.

THE CLAIMS DEFINING THE INVENTION ARE AS FOLLOWS:

1. A system for loading and unloading a surgical cassette having a peristaltic pump tube from a cassette receiving portion of a surgical console, including:

5 (a) a peristaltic pump roller head located in the cassette receiving portion of the surgical console, the roller head having a body member and a plurality of rollers connected therewith for engaging the pump tube, the roller head body member including a notch for guiding the tube onto and off the
10 rollers during loading and unloading of the cassette, respectively; and

(b) an extendable cylinder within the cassette receiving portion of the surgical console aligned to engage the peristaltic pump tube and adapted to assist in guiding the tube off the rollers of the roller head during unloading of the surgical cassette.

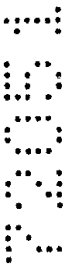

15 2. A system as claimed in claim 1 wherein the body member of the roller head includes a first disc-shaped element having the plurality of rollers extending therefrom and spaced therearound, the notch being located in a periphery of the first disc element between adjacent rollers.



20 3. A system as claimed in claim 1 or claim 2 wherein the notch includes a flared portion and a bevelled portion for use in guiding the peristaltic pump tube onto and off the rollers during loading and unloading of the surgical cassette, respectively.



25 4. A system as claimed in claim 3 wherein the bevelled portion of the notch is located at a leading edge region of the notch and the flared portion is located at a trailing edge region of the notch, the leading edge region and the trailing edge region of the notch being in relation to direction of roller head rotation for
30 loading of the surgical cassette.



5. A system as claimed in claim 4 wherein the disc element has an outer side and an inner side, the plurality of rollers extending inwardly from the inner side of the disc, and wherein the flared portion projects outwardly of the outer side and the bevelled portion is angled inwardly of the outer side.

5

6. A system as claimed in any one of the preceding claims wherein the extendable cylinder is arranged to engage and move the peristaltic pump tube in a direction substantially perpendicular to the longitudinal extent of the tube.

10 7. A surgical console including:

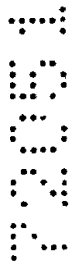

(a) a peristaltic pump roller head having a body member and a plurality of rollers connected therewith for engaging a peristaltic pump tube, the roller head body member including a notch for guiding the tube both onto and off the rollers during loading and unloading of the cassette, respectively;

15 (b) a removable cassette having a peristaltic pump tube stretched over the peristaltic pump roller head; and

(c) an extendable cylinder aligned to engage the peristaltic pump tube and adapted to assist in guiding the tube off the rollers of the roller head during unloading of the surgical cassette.



20 8. A surgical console as claimed in claim 7 wherein the body member of the roller head includes a first disc-shaped element the plurality of rollers extending from and being spaced around a side of the first disc element, the notch being located in a periphery of the first disc element between adjacent rollers.

25 9. A system as claimed in claim 7 or claim 8 wherein the notch includes a flared portion and a bevelled portion for use in guiding the peristaltic pump tube both onto and off the rollers during loading and unloading of the surgical cassette, respectively.

30

10. A system as claimed in claim 9 wherein the bevelled portion of the notch is located at a leading edge region of the notch and the flared portion is located



at a trailing edge region of the notch, the leading edge region and the trailing edge region of the notch being in relation to direction of roller head rotation for loading of the surgical cassette.

5 11. A system as claimed in claim 10 wherein the disc element has an outer side and an inner side, the plurality of rollers extending inwardly from the inner side of the disc, and wherein the flared portion projects outwardly of the outer side and the bevelled portion is angled inwardly of the outer side.

10 12. A system as claimed in any one of claims 7 to 11 wherein the extendable cylinder is arranged to engage and move the peristaltic pump tube in a direction substantially perpendicular to the longitudinal extent of the tube.



15 13. A system for loading and unloading a surgical cassette substantially as herein described with reference to the accompanying drawings.

14. A surgical console substantially as herein described with reference to the accompanying drawings.



20 DATED: 15 December 1998
PHILLIPS ORMONDE & FITZPATRICK
Attorneys for:
ALCON LABORATORIES, INC.

25



15 16 17 18 19 20 21 22 23 24 25 26 27 28 29 30 31 32 33 34 35 36 37 38 39 40 41 42 43 44 45 46 47 48 49 50 51 52 53 54 55 56 57 58 59 60 61 62 63 64 65 66 67 68 69 70 71 72 73 74 75 76 77 78 79 80 81 82 83 84 85 86 87 88 89 90 91 92 93 94 95 96 97 98 99 100

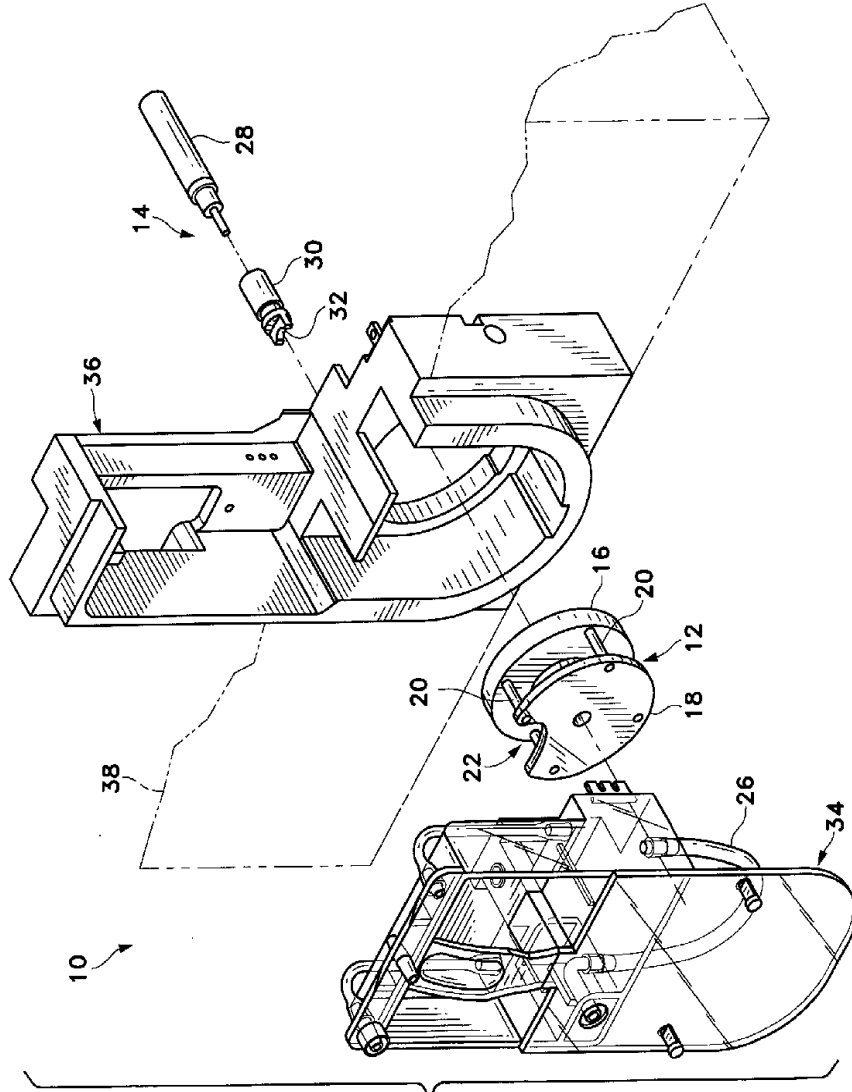

FIG. 1

2/5 70251/96

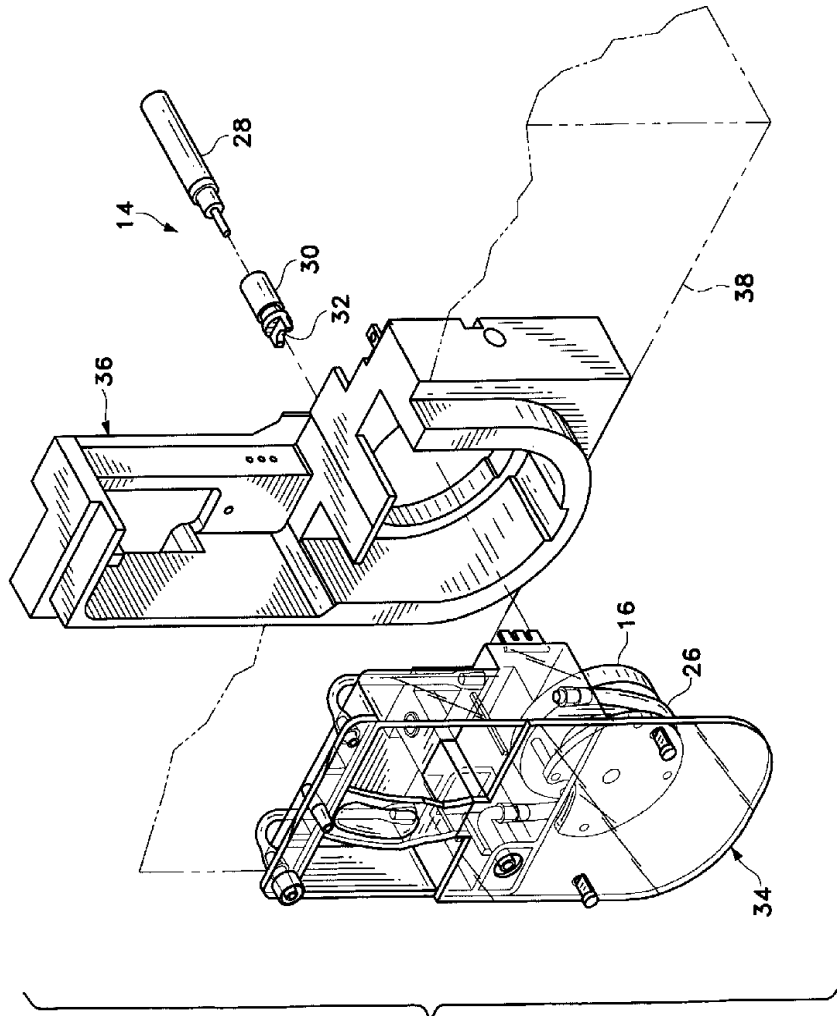

FIG. 2

16 18 26 28 30 32 34 36 38

3/5

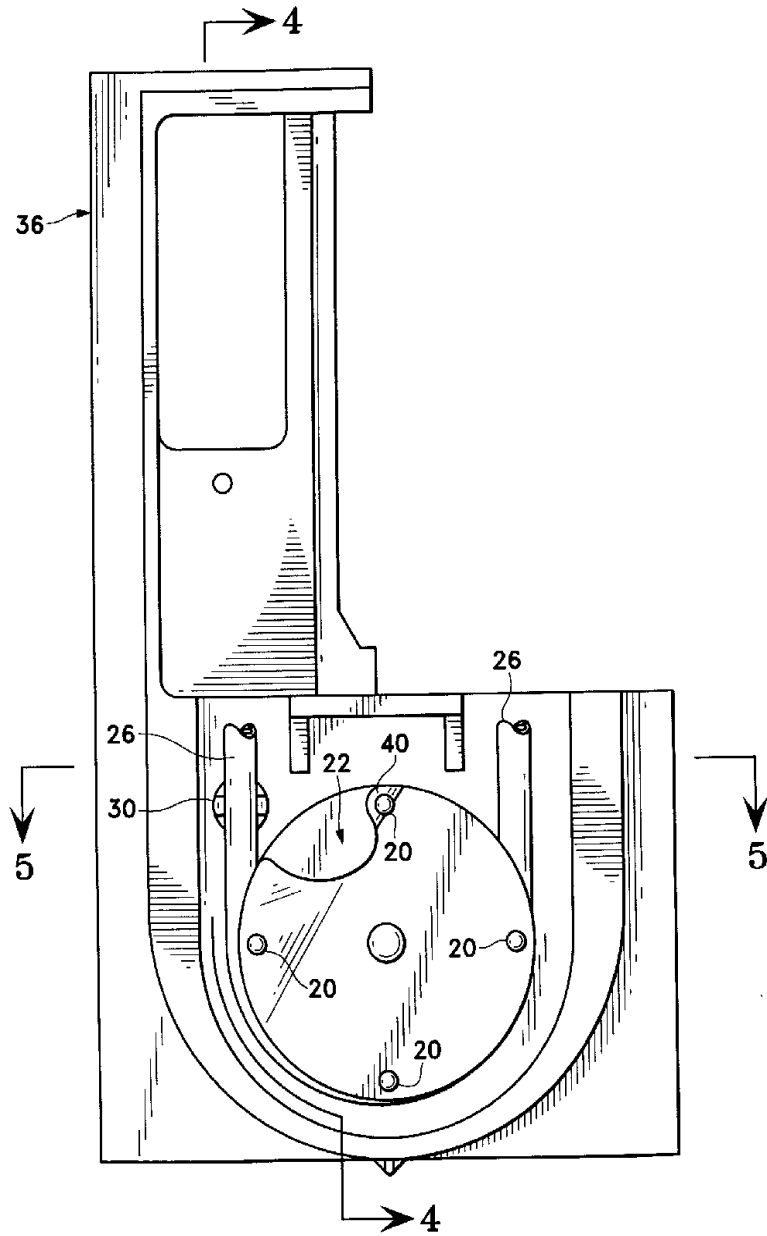

FIG. 3

4/5

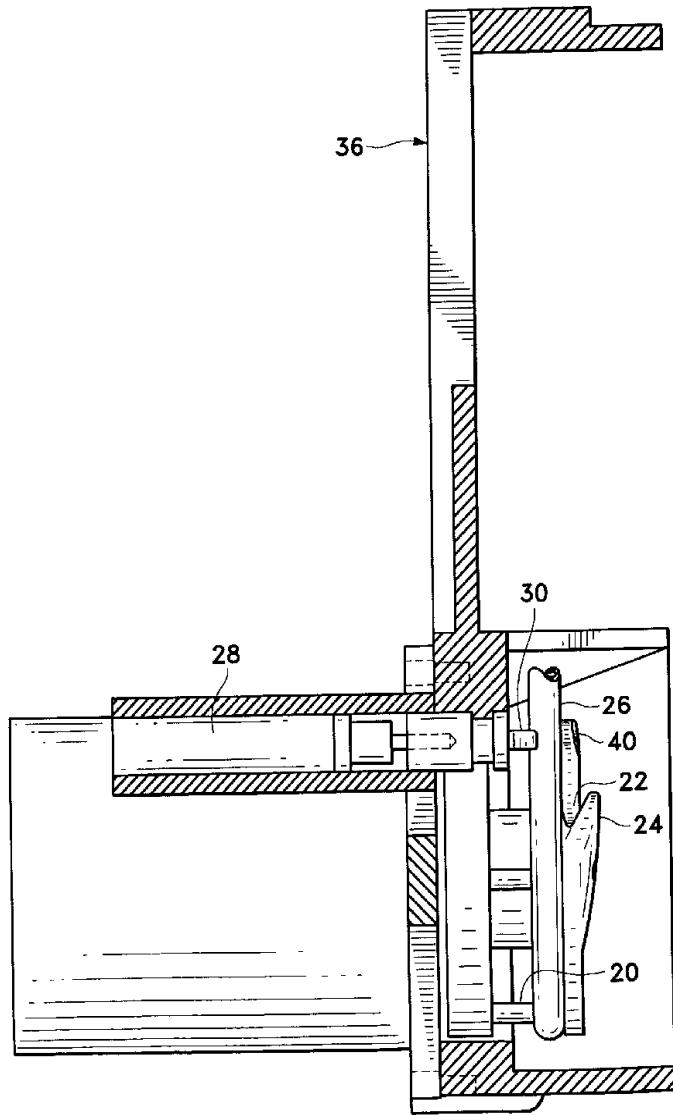

FIG. 4

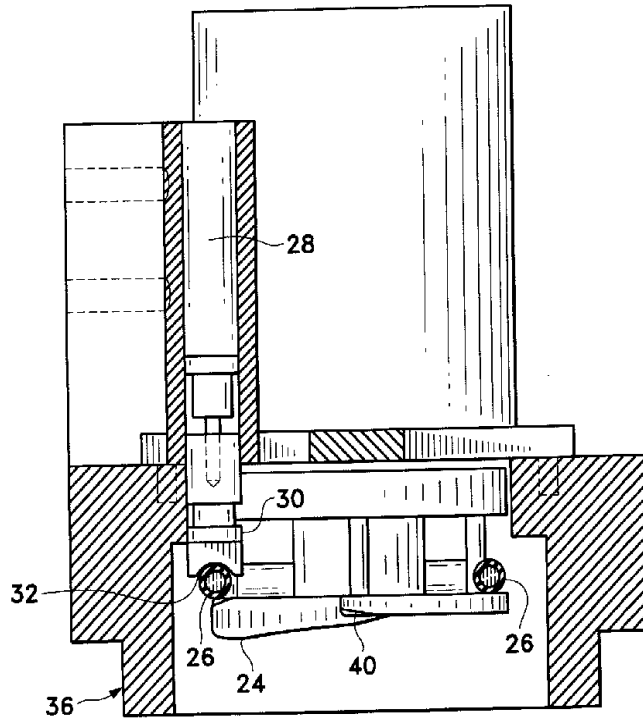

FIG. 5

5
4
3
2
1