

(19) World Intellectual Property Organization
International Bureau



(43) International Publication Date
27 November 2003 (27.11.2003)

PCT

(10) International Publication Number
WO 03/096885 A2

- (51) International Patent Classification⁷: **A61B**
- (21) International Application Number: PCT/US03/15830
- (22) International Filing Date: 19 May 2003 (19.05.2003)
- (25) Filing Language: English
- (26) Publication Language: English
- (30) Priority Data:
60/381,601 17 May 2002 (17.05.2002) US
10/243,556 13 September 2002 (13.09.2002) US
- (71) Applicant: **ONUX MEDICAL, INC.** [US/US]; 5 Merrill Drive, Hampton, NH 03842 (US).
- (72) Inventors: **SANCOFF, Gregory, E.**; 120 Mill Road, North Hampton, NH 03862 (US). **DiCARLO, Joseph, A.**; 2 Litchfield Road, Londonderry, NH 03053 (US). **FIELD, Frederic, P.**; 5 Woodland Road, North Hampton, NH 03862 (US). **FOGG, Douglas, A.**; 15 South Pleasant Street, Merrimac, MA 01860 (US). **PUGSLEY, Charles, H., Jr.**; 31 Clark Circle, Pelham, NH 03076 (US).
- (74) Agent: **PANDISCIO, Mark, J.**; Pandiscio & Pandiscio, 470 Totten Pond Road, Waltham, MA 02451-1914 (US).
- (81) Designated States (*national*): AE, AG, AL, AM, AT, AU, AZ, BA, BB, BG, BR, BY, BZ, CA, CH, CN, CO, CR, CU, CZ, DE, DK, DM, DZ, EC, EE, ES, FI, GB, GD, GE, GH, GM, HR, HU, ID, IL, IN, IS, JP, KE, KG, KP, KR, KZ, LC, LK, LR, LS, LT, LU, LV, MA, MD, MG, MK, MN, MW, MX, MZ, NO, NZ, PL, PT, RO, RU, SD, SE, SG, SK, SL, TJ, TM, TR, TT, TZ, UA, UG, UZ, VN, YU, ZA, ZW.
- (84) Designated States (*regional*): ARIPO patent (GH, GM, KE, LS, MW, MZ, SD, SL, SZ, TZ, UG, ZM, ZW), Eurasian patent (AM, AZ, BY, KG, KZ, MD, RU, TJ, TM), European patent (AT, BE, BG, CH, CY, CZ, DE, DK, EE, ES, FI, FR, GB, GR, HU, IE, IT, LU, MC, NL, PT, RO, SE, SI, SK, TR), OAPI patent (BF, BJ, CF, CG, CI, CM, GA, GN, GQ, GW, ML, MR, NE, SN, TD, TG).
- Published:**
— *without international search report and to be republished upon receipt of that report*
- For two-letter codes and other abbreviations, refer to the "Guidance Notes on Codes and Abbreviations" appearing at the beginning of each regular issue of the PCT Gazette.*

(54) Title: SURGICAL SUTURING INSTRUMENT AND METHOD OF USE

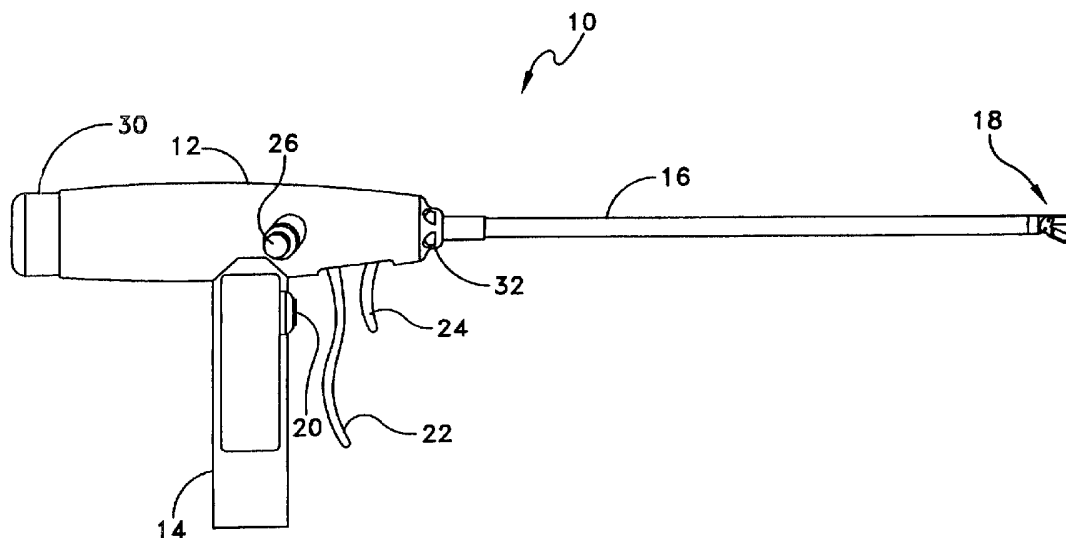

(57) Abstract: A device is disclosed for introducing a flexible elongated element through at least two portions of a subject. In an embodiment, the device includes a proximal end and a distal end, as well as an advancement unit for longitudinally advancing the flexible elongated element toward the distal end such that a proximal end of the elongated element may pass from the distal end of said device with sufficient force to pass through the portion of the subject. The device also includes a securing unit for variably adjusting a securing force applied by the flexible elongated element to secure together the portions of the subject.



WO 03/096885 A2

SURGICAL SUTURING INSTRUMENT AND METHOD OF USEReference To Earlier Applications

This is a continuation-in-part of (1) pending
5 prior U.S. Patent Application Serial No. 10/014,991,
filed 12/11/01 by Gregory E. Sancioff et al. for
SURGICAL SUTURING INSTRUMENT AND METHOD OF USE
(Attorney's Docket No. ONUX-4 CON); and (2) pending
prior U.S. Patent Application Serial No. 10/243,556,
10 filed 09/13/02 by Gregory E. Sancioff et al. for
SURGICAL SUTURING INSTRUMENT AND METHOD OF USE
(Attorney's Docket No. ONUX-30).

This patent application also claims benefit of
pending prior U.S. Provisional Patent Application
15 Serial No. 60/381,601, filed 05/17/02 by Joseph A.
DiCarlo et al. for SURGICAL SUTURING SYSTEM AND METHOD
OF USE (Attorney's Docket No. ONUX-32 PROV).

The three above-identified documents are hereby
incorporated herein by reference.

- 2 -

Field Of The Invention

This invention relates to medical instruments and procedures in general, and more particularly to suturing instruments and methods for suturing.

5

Background Of The Invention

Suturing instruments are typically used to draw together two or more portions of a subject patient (e.g., tissue such as muscle or skin) or to attach an object to the patient (e.g., to attach a piece of surgical mesh to the abdominal wall of the patient during hernia repair surgery).

10

Certain suturing instruments employ a needle that precedes a length of suture material through a subject.

15

For example, U.S. Patents Nos. 3,470,875; 4,027,608; 4,747,358; 5,308,353; 5,674,230; 5,690,653; 5,759,188; and 5,766,186 generally disclose suturing instruments in which a needle, with trailing suture material, is passed through a subject.

20

U.S. Patents Nos. 4,890,615; 4,935,027; 5,417,700; and 5,728,112 generally disclose suturing instruments in which suture material is passed through the end of a

- 3 -

hollow needle after that needle has passed through a subject.

5 With all of the foregoing devices, a needle must be passed through the subject in order to deploy the suture. This is generally undesirable, since the needle typically leaves a larger hole in the subject than is necessary to accommodate only the suture material. In this respect it should be appreciated that it is generally desirable to alter each portion of
10 the material being sutured as little as possible.

A suturing instrument has been devised which permits the suture material itself to pierce the subject without the use of a needle. However, this device does not permit sufficient flexibility with
15 regard to the amount of tension that may be applied to the suture and tissue.

More particularly, U.S. Patent No. 5,499,990 discloses a suturing instrument in which a 0.25 mm stainless steel suturing wire is advanced to the distal
20 end of a suturing instrument, whereupon the distal end of the suturing wire is caused to travel in a spiral direction so as to effect stitches joining together two

- 4 -

portions of a subject. After the spiral is formed, the beginning and end portions of the suture may be bent toward the tissue in order to inhibit retraction of the suture wire into the tissue upon removal of the suturing instrument. The stainless steel wire is sufficiently firm to hold this locking set. In addition, after the spiral is formed, the radius of the deployed suture spiral may then be decreased by advancing an outer tube over a portion of the distal end of the instrument. Again, the stainless steel wire is sufficiently firm to hold this reducing set.

Unfortunately, however, such a system does not permit sufficient flexibility in all situations with regard to the appropriate amount of tension to be applied to the subject, since the wire is relatively firm (i.e., firm enough to hold its sets). Such a system also does not provide sufficient flexibility with regard to the appropriate type of suture stitch to be applied, since the device is specifically configured to provide only a spiral suture stitch.

In contrast to the aforementioned limitations of the suturing instrument of U.S. Patent No. 5,499,990,

- 5 -

it is desirable that a suturing instrument approximate the portions of the material which is to be joined in the correct physiological relationship, and to urge the portions together with an appropriate amount of force.

5 If too much force (or tension) is applied to the suture material, then the subject portions may become necrotic or the sutures may cut through the subject. If too little tension is applied to the suture material, then the healing process may be impaired.

10 U.S. Patent No. 4,453,661 discloses a surgical instrument for applying staples. The staples are formed from the distal end of a length of wire. The distal end of the wire is passed through a subject, and thereafter contacts a die that causes the wire to bend,
15 thereby forming the staple. The wire is sufficiently firm to take the set imposed by the die. The staple portion is then cut from the wire by a knife. Again, such a system suffers from the fact that it does not permit sufficient flexibility in all situations with
20 regard to the appropriate tension to be applied to the subject, since the attachment is made by a staple which has a predefined geometry and is formed with relatively

- 6 -

firm wire. In addition, the system is limited as to the type of fastening which may be applied, since the surgical instrument is limited to only applying wire staples.

5 There is a need, therefore, for a new suturing device that permits minimally disruptive suturing and permits flexibility in the placement, application, and tensioning of the suture material.

10 Summary Of The Invention

 The invention provides a device for introducing a flexible elongated element through a subject. In one embodiment, the device includes a proximal end and a distal end, as well as an advancement unit for
15 longitudinally advancing the flexible elongated element toward the distal end of the device such that a distal end of the flexible elongated element may pass from the distal end of the device with sufficient force to pass through the subject. The device also includes a
20 securing unit for variably adjusting a securing force applied by the flexible elongated element so as to provide the desired securement to the subject.

- 7 -

In further embodiments, the device includes a guide tube for guiding the flexible elongated element through the device, toward the distal end of the device, as well as a rotation unit for rotating the distal end of the device so as to cause the flexible elongated element to wrap around itself, whereby to adjustably apply the securing force to the flexible elongated element.

In another aspect of the invention, there is provided a suturing device comprising: a housing; a shaft extending distally from said housing, at least a portion of said shaft being flexible; a pair of opposing jaws located at a distal end of said shaft; a suture drive mechanism located in said housing and adapted to advance suture material through said shaft, through one of said jaws, through a subject to be sutured, and into the other jaw; and a jaw rotation mechanism located in said housing and adapted to rotate said jaws so as to secure the suture material to the subject.

In another aspect of the invention, there is provided a suturing device comprising: a housing; a

- 8 -

shaft extending distally from said housing; a pair of opposing jaws located at a distal end of said shaft, said opposing jaws being (i) pivotally connected to said distal end of said shaft, and (ii) pivotally
5 connected to an inner yoke movable relative to said distal end of said shaft, whereby movement of said inner yoke in a distal direction causes said opposing jaws to open relative to one another, and movement of said inner yoke in a proximal direction causes said
10 opposing jaws to close relative to one another; a suture drive mechanism located in said housing and adapted to advance suture material through said shaft, through one of said jaws, through a subject to be sutured, and into the other jaw; and a jaw rotation
15 mechanism located in said housing and adapted to rotate said jaws so as to secure the suture material to the subject.

In another aspect of the invention, there is provided a suturing device comprising: a housing; a
20 shaft extending distally from said housing, at least a portion of said shaft being flexible; a pair of movable jaws pivotally connected to the distal end of said

- 9 -

shaft in opposing relation such that said jaws can open and close relative to one another; a suture drive mechanism located in said housing and adapted to advance suture material through said shaft, through one of said jaws, through a subject to be sutured, and into the other jaw; a jaw rotation mechanism located in said housing and adapted to rotate said jaws so as to secure the suture material to the subject.

In another aspect of the invention, there is provided a suturing device comprising: a housing; a shaft extending distally from said housing; a pair of opposing jaws located at a distal end of said shaft; a suture drive mechanism located in said housing and adapted to advance suture material through said shaft, through one of said jaws, through a subject to be sutured, and into the other jaw; a jaw rotation mechanism located in said housing and adapted to rotate said jaws so as to secure the suture material to the subject; and a source of suture material located in the device, said suture material comprising (i) a distal portion having properties favorable for penetrating, twisting and cutting operations, and (ii) a proximal

- 10 -

portion having properties favorable for driving operations, said source of suture material being located in the device so that said proximal portion is engaged by said suture drive mechanism.

5 In another aspect of the invention, there is provided a suture material, comprising: a distal portion having properties favorable for penetrating, twisting and cutting operations; and a proximal portion having properties favorable for driving operations.

10 In another aspect of the invention, there is provided a method for treating gastroesophageal reflux disease (GERD), comprising: providing a suturing device comprising: a housing; a shaft extending distally from said housing; a pair of opposing jaws located at a
15 distal end of said shaft; a suture drive mechanism located in said housing and adapted to advance suture material through said shaft, through one of said jaws, through a subject to be sutured, and into the other jaw; and a jaw rotation mechanism located in said
20 housing and adapted to rotate said jaws so as to secure the suture material to the subject; advancing the distal end of the suturing device into a patient's

- 11 -

stomach so that the distal end of the suturing device is adjacent to the wall of the stomach below the lower esophageal sphincter (LES); gathering together portions of the stomach wall below the LES with the pair of
5 opposing jaws; operating the suture drive mechanism so as to advance suture material through the gathered-together portions of the stomach wall; and operating the jaw rotation mechanism so as to secure the suture material to the subject and thereby secure
10 together the gathered-together portions of the stomach wall.

In another aspect of the invention, there is provided a method for effecting hemostasis, comprising: providing a suturing device comprising: a housing; a
15 shaft extending distally from said housing; a pair of opposing jaws located at a distal end of said shaft; a suture drive mechanism located in said housing and adapted to advance suture material through said shaft, through one of said jaws, through a subject to be
20 sutured, and into the other jaw; and a jaw rotation mechanism located in said housing and adapted to rotate said jaws so as to secure the suture material to the

- 12 -

subject; advancing the distal end of the suturing device into a patient adjacent to tissue which would benefit by effecting hemostasis; gathering together portions of the tissue which would benefit by effecting hemostasis with the pair of opposing jaws; operating the suture drive mechanism so as to advance suture material through the gathered-together portions of the tissue; and operating the jaw rotation mechanism so as to secure the tissue and thereby effect hemostasis.

5
10 In another aspect of the invention, there is provided a suturing device comprising:

a housing;

15 a shaft extending distally from said housing, at least a portion of said shaft being flexible, and said shaft having an outer surface characterized by a plurality of peaks and a plurality of troughs, whereby to make point contact with the working lumen of an endoscope;

20 a pair of opposing jaws located at a distal end of said shaft;

a suture drive mechanism located in said housing and adapted to advance suture material through said

- 13 -

shaft, through one of said jaws, through a subject to be sutured, and into the other jaw; and

a jaw rotation mechanism located in said housing and adapted to rotate said jaws so as to secure the suture material to the subject.

In another aspect of the invention, there is provided a suturing device comprising:

a housing;

a shaft extending distally from said housing, at least a portion of said shaft being flexible;

a pair of movable jaws pivotally connected to the distal end of said shaft in opposing relation such that said jaws can open and close relative to one another, said opposing jaws being operated by a jaw actuating mechanism extending through said shaft;

a suture drive mechanism located in said housing and adapted to advance suture material through said shaft, through one of said jaws, through a subject to be sutured, and into the other jaw;

a jaw rotation mechanism located in said housing and adapted to rotate said jaws so as to secure the suture material to the subject; and

- 14 -

a cutting mechanism adapted for selective movement through said one of said jaws for engagement with, and severing of, suture material extending through said one of said jaws, said cutting mechanism being operated by
5 a cutter actuating mechanism extending through said shaft; and

further wherein said jaw actuating mechanism, said suture material and said cutter actuating mechanism are disposed substantially symmetrically within said shaft.

10 In another aspect of the invention, there is provided a suturing device comprising:

a housing;

a shaft extending distally from said housing;

15 a pair of opposing jaws located at a distal end of said shaft;

a suture drive mechanism located in said housing and adapted to advance suture material through said shaft, through one of said jaws, through a subject to
20 be sutured, and into the other jaw, said wire advancing actuator comprising a sliding cage adapted for distal and proximal movement within said handle, said sliding

- 15 -

cage comprising a flexible finger, and further wherein
(1) distal movement of said sliding cage causes said
finger to bindingly engage said suture wire and drive
it distally, and (2) proximal movement of said sliding
5 cage causes said finger to disengage from binding
engagement with said suture wire;

a jaw rotation mechanism located in said housing
and adapted to rotate said jaws so as to secure the
suture material to the subject; and

10 a source of suture material located in the device.

In another aspect of the invention, there is
provided a method for treating gastroesophageal reflux
disease (GERD), comprising:

providing a suturing device comprising:

15 a housing;

a shaft extending distally from said housing,
at least a portion of said shaft being flexible, and
said shaft having an outer surface characterized by a
plurality of peaks and a plurality of troughs, whereby
20 to make point contact with the working lumen of an
endoscope;

- 16 -

a pair of opposing jaws located at a distal end of said shaft;

a suture drive mechanism located in said housing and adapted to advance suture material through said shaft, through one of said jaws, through a subject to be sutured, and into the other jaw; and

a jaw rotation mechanism located in said housing and adapted to rotate said jaws so as to secure the suture material to the subject;

advancing the distal end of the suturing device into a patient's stomach so that the distal end of the suturing device is adjacent to the wall of the stomach below the lower esophageal sphincter (LES);

gathering together portions of the stomach wall below the LES with the pair of opposing jaws;

operating the suture drive mechanism so as to advance suture material through the gathered-together portions of the stomach wall; and

operating the jaw rotation mechanism so as to secure the suture material to the subject and thereby secure together the gathered-together portions of the stomach wall.

- 17 -

In another aspect of the invention, there is provided a method for treating gastroesophageal reflux disease (GERD), comprising:

providing a suturing device comprising:

- 5 a housing;
- a shaft extending distally from said housing;
- a pair of opposing jaws located at a distal end of said shaft, said opposing jaws being operated by a jaw actuating mechanism extending through said shaft;
- 10 a suture drive mechanism located in said housing and adapted to advance suture material through said shaft, through one of said jaws, through a subject to be sutured, and into the other jaw; and
- a jaw rotation mechanism located in said housing and adapted to rotate said jaws so as to secure the suture material to the subject; and
- 15 a cutting mechanism adapted for selective movement through said one of said jaws for engagement with, and severing of, suture material extending
- 20 through said one of said jaws, said cutting mechanism being operated by a cutter actuating mechanism extending through said shaft; and

- 18 -

further wherein said jaw actuating mechanism, said suture material and said cutter actuating mechanism are disposed substantially symmetrically within said shaft;

5 advancing the distal end of the suturing device into a patient's stomach so that the distal end of the suturing device is adjacent to the wall of the stomach below the lower esophageal sphincter (LES);

10 gathering together portions of the stomach wall below the LES with the pair of opposing jaws;

 operating the suture drive mechanism so as to advance suture material through the gathered-together portions of the stomach wall; and

15 operating the jaw rotation mechanism so as to secure the suture material to the subject and thereby secure together the gathered-together portions of the stomach wall.

 In another aspect of the invention, there is provided a method for treating gastroesophageal reflux disease (GERD), comprising:

20 providing a suturing device comprising:
 a housing;

- 19 -

a shaft extending distally from said housing,
at least a portion of said shaft being flexible;

a pair of opposing jaws located at a distal
end of said shaft;

5 a suture drive mechanism located in said
housing and adapted to advance suture material through
said shaft, through one of said jaws, through a subject
to be sutured, and into the other jaw, said wire
advancing actuator comprising a sliding cage adapted
10 for distal and proximal movement within said handle,
said sliding cage comprising a flexible finger, and
further wherein (1) distal movement of said sliding
cage causes said finger to bindingly engage said suture
wire and drive it distally, and (2) proximal movement
15 of said sliding cage causes said finger to disengage
from binding engagement with said suture wire; and

a jaw rotation mechanism located in said
housing and adapted to rotate said jaws so as to secure
the suture material to the subject;

20 advancing the distal end of the suturing device
into a patient's stomach so that the distal end of the

- 20 -

suturing device is adjacent to the wall of the stomach
below the lower esophageal sphincter (LES);

gathering together portions of the stomach wall
below the LES with the pair of opposing jaws;

5 operating the suture drive mechanism so as to
advance suture material through the gathered-together
portions of the stomach wall; and

operating the jaw rotation mechanism so as to
secure the suture material to the subject and thereby
10 secure together the gathered-together portions of the
stomach wall.

Brief Description Of The Drawings

15 These and other objects and features of the
present invention will be more fully disclosed or
rendered obvious by the following detailed description
of the preferred embodiment of the invention, which is
to be considered together with the accompanying
drawings wherein like numbers refer to like parts, and
20 further wherein:

Fig. 1 is a side view of a suturing instrument
formed in accordance with the present invention;

- 21 -

Fig. 2 is a partial side view, partially in section, of the suturing instrument shown in Fig. 1;

Fig. 3 is a partial top view, partially in section, of the suturing instrument shown in Fig. 1;

5 Fig. 4 is a schematic partial side view showing some of the internal components of the suturing instrument shown in Fig. 1;

Fig. 4A is a perspective view of a drive barrel assembly incorporated in the suturing instrument shown
10 in Fig. 1;

Fig. 5 is a perspective view of a wire guide support unit incorporated in the suturing instrument shown in Fig. 1;

Fig. 6 is a perspective view of the suturing
15 instrument's wire supply cartridge, which includes the wire guide support unit shown in Fig. 5;

Fig. 7 is a perspective view, partially in section, of the wire supply cartridge shown in Fig. 6;

Fig. 8 is a perspective rear view of the drive
20 barrel assembly incorporated in the suturing instrument shown in Fig. 1, with the drive barrel assembly's release lever being shown in its closed position;

- 22 -

Fig. 9 is a perspective view of the proximal (i.e., rear) end of the drive barrel assembly shown in Fig. 8, with the release lever being shown in its open position;

5 Fig. 10 is a perspective view of the proximal (i.e., rear) end of the same drive barrel assembly, with the release lever being shown in its closed position, and with the wire guide and wire guide support unit being advanced relative to the drive
10 barrel assembly (but with the remainder of the wire supply cartridge being removed from view);

Fig. 11 is a schematic view taken along the line 11-11 of Fig. 4;

15 Fig. 12 is a side view of a shaft and an end effector portion of the suturing instrument shown in Fig. 1;

Fig. 13 is a side view of the end effector portion of the suturing instrument shown in Fig. 1;

20 Fig. 14 is a side view, partially in section, of the end effector portion shown in Fig. 13, with the end effector portion being shown with its cutting bar in its forward (i.e., non-cutting) position;

- 23 -

Fig. 15 is a side view, partially in section, of the end effector portion shown in Fig. 14, but with the end effector portion being shown with its cutting bar in its retracted (i.e., cutting) position;

5 Fig. 16 is a perspective view of the end effector portion of the suturing instrument shown in Fig. 1;

Figs. 17A - 17J show various steps in a suturing operation conducted with the suturing instrument shown in Fig. 1;

10 Fig. 18 is a sectional view showing one possible construction for the suturing instrument's fixed jaw portion and its associated cutting bar;

Fig. 19 is a side view showing a piece of wire cut with the apparatus shown in Fig. 18;

15 Fig. 20 is a sectional view showing another possible fixed construction for the suturing instrument's fixed jaw portion and its associated cutting bar;

20 Fig. 21 is a side view showing a piece of wire cut with the apparatus shown in Fig. 20;

Fig. 22 is a side view, partially in section, of the end effector portion of the device, wherein the end

- 24 -

effector portion includes a piezoelectric element to aid in wire penetration;

Fig. 23A is a schematic diagram of the device's fixed jaw portion, illustrating how the suture wire may sometimes curve as it exits the fixed jaw portion;

Fig. 23B is a schematic diagram of a modified form of the device's fixed jaw portion, illustrating how the profile of the device can be modified so as to counteract the aforementioned wire curvature;

Fig. 23C is a schematic diagram of a modified form of the device's movable jaw portion, illustrating how the mouth of the movable jaw portion's opening may be enlarged so as to facilitate suture capture;

Fig. 24 is a schematic diagram of a modified form of the device, wherein one or more legs have been provided to help stabilize the tissue during suturing;

Fig. 25 is a schematic diagram of another modified form of the device, wherein a second set of jaws have been added to the device to help stabilize the tissue during suturing;

Figs. 26-29 are schematic diagrams of a preferred embodiment of the present invention illustrating a

- 25 -

novel procedure to address gastroesophageal reflux disease (GERD);

Fig. 29A is a schematic end view showing an alternative form of instrument shaft disposed in the working lumen of an endoscope;

Fig. 29B is a schematic end view showing another alternative form of instrument shaft disposed in the working lumen of an endoscope;

Fig. 29C is a schematic end view showing one possible way to position the shaft's working elements (i.e., the jaw linkage, wire cutting linkage and wire guide) within the instrument shaft;

Fig. 29D is a schematic end view showing another possible way to position the shaft's working elements within the instrument shaft;

Fig. 29E shows an alternative construction for the instrument's shaft;

Figs. 30-39 are schematic diagrams of modified forms of suturing instruments with two movable jaw portions for gripping tissue;

Fig. 40 is a schematic diagram of a supply suture wire having a softer distal wire portion optimized for

- 26 -

tissue penetration, twisting and cutting, and a harder proximal wire portion optimized for driving; and

Figs. 41-55 show an alternative construction for the proximal end of the suturing instrument, with Figs. 41 and 42 showing details of the instrument's scope mount, Figs. 43-46 showing details of the instrument's jaw actuation mechanism, Figs. 47-53 showing details of the instrument's wire advance mechanism, and Figs. 54 and 55 showing details of the instrument's cutting bar actuation mechanism.

Detailed Description Of The Preferred Embodiment

Overview

Looking first at Fig. 1, there is shown a suturing instrument 10 which comprises a preferred embodiment of the present invention. Suturing instrument 10 includes a housing 12, a handle 14, a shaft 16 and an end effector 18. Suturing instrument 10 also includes a wire advance button 20, a jaw closing actuator 22, a wire cutting actuator 24, a left-thumb-actuated rotation button 26, and a right-thumb-actuated rotation

- 27 -

button 28 (Fig. 3). Suturing instrument 10 also includes a wire supply cartridge 30, as well as a shaft retaining nut 32. Shaft retaining nut 32 allows shaft 16 to be dismounted from the remainder of the device for cleaning purposes.

As will be discussed in further detail below, generally during use, suture wire (comprising wire formed of metal or any other suitable material having the required flexibility and stiffness) is drawn from a winding in wire supply cartridge 30 and is pushed through housing 12 and shaft 16 to end effector 18, which includes a pair of opposing jaw portions. The jaw portions may be brought together around the material which is to be sutured by actuating jaw closing actuator 22 when the jaw portions are positioned at an appropriate surgical location. The suture wire is driven through housing 12 and shaft 16 to end effector 18 by actuating wire advance button 20. The suture wire is driven from one jaw portion to the other jaw portion with sufficient force to penetrate the tissue placed between the jaw portions, and the suture wire is permitted to pass through the second jaw

- 28 -

portion. The jaw portions are then permitted to separate and move away from the tissue, leaving the suture wire extending from the subject tissue to each of the two jaw portions. Shaft 16 and end effector 18 (together with wire supply cartridge 30) may then be rotated with respect to housing 12 and handle 14 by actuating either left-thumb-actuated rotation button 26 or right-thumb-actuated rotation button 28. This causes the portions of the suture wire that extend from the tissue to be twisted about one another so as to form a closed loop extending through the tissue. It will be appreciated that the size of this closed loop may be adjustably reduced by increasing the degree of twisting in the wire. The twisted loop of suture wire may then be cut off, at end effector 18, from the remaining portion of the suture wire that extends back through the suturing instrument. Such cutting may be effected by actuating wire cutting actuator 24.

As will be discussed in further detail below, wire supply cartridge 30 may be supplied separately from suturing instrument 10, with the wire supply cartridge 30 being loaded into suturing instrument 10 prior to

- 29 -

commencing a suturing operation. As will also be discussed in further detail below, wire supply cartridge 30 may be disposable, such that the cartridge may be discarded after all of its wire has been used up.

5

- 30 -

Construction Details

As shown in Figs. 2 and 4, handle 14 provides a cavity that may receive batteries 34. In other embodiments, the unit may be powered remotely via a power transmission cord or any other source of suitable power.

Batteries 34 supply a ground (or negative) potential to a ground connector post 36 (Fig. 2), which in turn communicates with a rotary ground communicator 38. Rotary ground communicator 38 permits electrical contact to be maintained with ground connector post 36 when rotary ground communicator 38 is rotated with respect to ground connector post 36, as occurs when shaft 16 and end effector 18 are rotated so as to twist closed suture wire extending through the tissue.

Batteries 34 supply a positive potential to wire advance button 20, and to a first connector post 40, which in turn communicates with a first rotary electrical communicator 42. First rotary electrical communicator 42 permits electrical contact to be maintained with first connector post 40 when first rotary electrical communicator 42 is rotated with

- 31 -

respect to first connector post 40. The positive potential from batteries 34 is also supplied (in parallel) to each thumb-activated rotation button 26, 28 (Fig. 3), and to a second connector post 44 (Fig. 2), which in turn communicates with a second rotary electrical communicator 46. Again, second rotary electrical communicator 46 permits electrical contact to be maintained with second connector post 44 when second rotary electrical communicator 46 is rotated with respect to second connector post 44. Each of the connector posts 36, 40 and 44 may be spring-biased so as to remain in contact with its respective rotary communicator. In view of the foregoing construction, the positive potentials may be switched on by depressing the respective actuator button 20, 26, 28. Handle 14 also includes a cap 48 which may be removed so as to permit insertion of batteries 34.

First rotary electrical communicator 42 is in electrical communication with a wire advance motor 50 shown in Figs. 2 and 4. The output shaft of wire advance motor 50 is coupled to a miter drive gear 52, which is in turn coupled to a miter follower gear 54.

- 32 -

Miter follower gear 54 is coupled to a drive wheel 56 which contacts the suture wire 58, as will be described in further detail below with reference to Figs. 5-10.

5 Second rotary electrical communicator 46 is in electrical communication with a shaft rotation motor 60 (Figs. 3 and 4), the output of which is coupled to a pinion gear 62 (Figs. 4, 4A and 11) that rotates along an internal gear 64 (Figs. 4 and 11). As shown in Fig. 3, left-thumb-actuated rotation button 26 and
10 right-thumb-activated rotation button 28 may be provided to permit the user to use the thumb of either their left hand or their right hand, respectively, so as to actuate shaft rotation motor 60. In this respect it will be appreciated that, inasmuch as
15 left-thumb-actuated rotation button 26 and right-thumb-actuated rotation button 28 are wired in parallel, shaft rotation motor 60 will rotate in the same direction regardless of which button (i.e., button 26 or button 28) may be actuated.

20 Jaw closing actuator 22 (Figs. 2 and 4) is coupled to a jaw linkage coupler 66, which in turn contacts a jaw linkage 68 (Figs. 2 and 14). When jaw closing

- 33 -

actuator 22 is pulled toward handle 14 (Fig. 2), jaw closing actuator 22 pivots on its pivot pin 67 (Fig. 4) so as to drive jaw linkage coupler 66 distally, against the force of biasing spring 69, and so as to cause the jaw linkage 68 to move forward toward the distal end of suturing instrument 10. This action will in turn cause movable jaw portion 98 to close on fixed jaw portion 96 (Fig. 17A), as will hereinafter be discussed in further detail. When jaw closing actuator 22 is subsequently released, biasing spring 69 (Fig. 4) drives jaw linkage coupler 66 proximally, so as to cause jaw linkage 68 to move proximally. This action will cause movable jaw portion 98 to open relative to fixed jaw portion 96 (Fig. 14), as will hereinafter be discussed in further detail. The action of jaw linkage 68 at the distal end of the device is discussed further below with reference to Figs. 13 and 14.

Wire cutting actuator 24 is coupled to a wire cutting linkage coupler 70 (Figs. 2 and 4), which in turn contacts a wire cutting linkage 72 (Figs. 2, 14 and 15). When wire cutting actuator 24 is pulled toward handle 14 (Fig. 2), wire cutting actuator 24

- 34 -

pivots on its pivot pin 73 (Fig. 4) so as to drive wire cutting linkage coupler 70 proximally, against the force of biasing spring 69, and so as to cause wire cutting linkage 72 to move proximally, away from the distal end of suturing instrument 10. This action will in turn cause cutting bar 104 (Fig. 14) to move proximally (Fig. 15) so as to effect wire cutting, as will hereinafter be discussed in further detail. When wire cutting actuator 24 is subsequently released, biasing spring 69 drives wire cutting linkage coupler 70 distally, so as to cause wire cutting linkage 72 to move distally. This action causes cutting bar 104 to move distally, so as to assume the position shown in Fig. 14. Wire cutting linkage 72 moves adjacent to, and independent of, jaw linkage 68 discussed above. The action of wire cutting linkage 72 at the distal end of the device is discussed further below with reference to Figs. 14 and 15.

The wire supply cartridge 30 shown in Fig. 1 includes a wire guide support unit 74, as shown in Figs. 5-7. A supply coil of suture wire 58 (comprising wire formed of metal or any other suitable material

- 35 -

having the required flexibility and stiffness) may be supplied in the base of cartridge 30 and is fed into the support unit 74 as shown in Fig. 7. A wire guide 76 surrounds suture wire 58, from support unit 74 to the distal end of suturing instrument 10, adjacent to end effector 18 (Figs. 5-7, 14 and 15). Wire guide 76 ensures that suture wire 58 does not bend or buckle as the suture wire is pushed through housing 12 and shaft 16. More particularly, wire guide 76 preferably forms a sufficiently close sliding fit with suture wire 58 such that suture wire 58 cannot bend or buckle as the suture wire is advanced through suturing instrument 10. At the same time, wire guide 76 is also formed so as to present a minimum of friction to suture wire 58 as the suture wire is advanced through the instrument. The foregoing characteristics are important, inasmuch as suture wire 58 is extremely thin and flexible and highly susceptible to bending or buckling in the absence of some sort of lateral support.

By way of example but not limitation, where suture wire 58 is formed out of stainless steel and has a diameter of 0.005 inch, wire guide 76 might have an

- 36 -

inside diameter of 0.008 inch and an outside diameter of 0.016 inch. In addition, wire guide 76 is preferably formed out of polytetrafluoroethylene (PTFE) or some other relatively lubricious material.

5 Alternatively, the interior of wire guide 76 may be coated with a lubricant so as to facilitate closely-supported, low-friction passage of the suture wire through the wire guide.

10 Further by way of example but not limitation, in one preferred form of the invention, suture wire 58 may comprise 316 LVM stainless steel having a tensile strength of 170 kpsi.

15 Although wire guide 76 extends through support unit 74 (Fig. 7), wire guide 76 has two openings 78 (one on either side of wire guide 76, only one of which is shown in Fig. 5) in the center of support unit 74. Openings 78 expose a portion of suture wire 58 so that wire drive wheel 56 (Fig. 8) may contact suture wire 58 and urge the suture wire forward toward the distal end
20 of suturing instrument 10, as will be discussed in detail below with reference to Figs. 8-10.

- 37 -

As shown in Figs. 2, 3, 4A and 8, housing 12 receives a drive barrel assembly 80 that contains the aforementioned motors 50 and 60, and provides a distally-extending barrel shaft 81 (Figs. 4A and 8), on the outside of which are located the rotary communicators 38, 42 and 46'. A recess 82 (Fig. 4A) is provided on the distal end of barrel shaft 81 for receiving a coupling pin 84 (Figs. 2 and 4) which is located on the proximal end of shaft 16, such that rotation of drive barrel assembly 80 causes rotation of coupling pin 84 and hence shaft 16. Drive barrel assembly 80 is rotationally held within housing 12 by bearings 86, as shown in Figs. 2 and 3.

Looking next at Figs. 7-10, wire supply cartridge 30 may be attached to drive barrel assembly 80 by rotating a release lever 87 away from the center of drive barrel assembly 80 (Figs. 8 and 9), so as to move a carriage 88 relative to drive barrel assembly 80. Most particularly, release lever 87 rides on a pin 90, and rotation of release lever 87 from the position shown in Fig. 8 to the position shown in Fig. 9 draws carriage 88, as well as a wire follower wheel 92, away

- 38 -

from the center of drive barrel assembly 80. Once wire follower wheel 92 is separated from wire drive wheel 56 by a sufficient distance to expose the drive barrel assembly's central passageway 93 (Fig. 9), wire guide 76 (overlying suture wire 58) may be inserted into passageway 93 (Fig. 10), and wire guide support unit 74 (Figs. 6, 7 and 10) may be inserted between wheels 56 and 92 (Fig. 10), such that wheels 56 and 92 contact either side of suture wire 58 through openings 78 formed in either side of wire guide 76. A biasing spring 94 (Figs. 8-10) is provided on carriage 88 to urge wire follower wheel 92 into close contact with suture wire 58. In other embodiments, wire follower wheel 92 may also be driven indirectly by wire drive wheel 56 in order to provide additional forces to move suture wire 58 distally (i.e., forward, toward the tool's end effector 18).

Pinion gear 62 (Figs. 4, 4A and 11) extends distally from drive barrel assembly 80 and engages the housing's internal gear 64, as shown in Figs. 4 and 11. As a result of this construction, when shaft rotation motor 60 is actuated, pinion gear 62 rotates around

- 39 -

internal gear 64, bringing with it the entire drive barrel assembly 80. This in turn causes shaft 16 to rotate, since shaft 16 is coupled to drive barrel assembly 80. More particularly, the rotation of drive barrel assembly 80 is transferred to shaft 16 through the shaft's coupling pin 84 (Figs. 2, 4 and 12), which is seated in recess 82 (Fig. 8) of drive barrel assembly 80.

End effector 18 (Figs. 1 and 13-16) includes a fixed jaw portion 96 and a movable jaw portion 98. Movable jaw portion 98 is coupled to the aforementioned jaw linkage 68 (Fig. 14) via a jaw linkage pin 100, such that when jaw linkage 68 is moved distally (i.e., by pulling jaw closing actuator 22 toward handle 14), jaw portion 98 is rotated about a pivot pin 102 (Fig. 13) and closes onto fixed jaw portion 96. Conversely, when jaw linkage 68 is moved proximally (i.e., by the power of biasing spring 69 acting on jaw linkage coupler 66 and hence jaw linkage 68), movable jaw portion 98 will open away from fixed jaw portion 96. It will be appreciated that the force of biasing spring 69 will normally keep movable jaw portion 98 open

- 40 -

relative fixed jaw portion 98 (Figs. 1, 13 and 14), unless and until jaw closing actuator 22 is activated so as to overcome the bias of spring 69.

5 Wire cutting linkage 72 (Figs. 2, 3, 14 and 15) is coupled to a cutting bar 104 (Figs. 14 and 15) that includes a small opening 106 through which suture wire 58 may pass, as will hereinafter be discussed in further detail. Preferably cutting bar 104 is slidably received in a passageway 107 (Figs. 14, 15, 16 and 17H) 10 formed in fixed jaw portion 96. In one position (Fig. 14), cutting bar 104 is positioned in fixed jaw portion 96 such that the cutting bar's opening 106 is aligned with a channel 108 formed in fixed jaw portion 96, whereby suture wire may be passed from the distal end 15 of wire guide 76, through channel 108 formed in fixed jaw portion 96 (where it undergoes an approximately 90 degree change of direction), through opening 106 in cutting bar 104, through a channel extension 108A formed in fixed jaw portion 96, and across to movable 20 jaw portion 98, as will hereinafter be discussed in further detail. However, when wire cutting linkage 72 is moved proximally by pulling wire cutting actuator 24

- 41 -

toward handle 14, cutting bar 104 is also moved
proximally (Fig. 15) so as to cut any suture wire
extending from channel 108 (in fixed portion 96) into
opening 106 (in cutting bar 104). In this respect it
5 will be appreciated that it is desirable to form
channel extension 108A with a length greater than
channel 108 (see Figs. 14 and 15) so as to prevent the
suture wire from being cut in two places (i.e., at
channel 108 and again at channel extension 108A) when
10 cutting bar 104 is moved proximally by pulling on wire
cutting actuator 24. At the same time, however, it
should also be appreciated that the fixed jaw portion's
channel 108 and channel extension 108A, and the cutting
bar's opening 106, are all sized, relative to suture
15 wire 58, so as to provide as much support as possible
to the suture wire as it passes through, and out of,
fixed jaw portion 96.

It will be appreciated that the force of biasing
spring 69 will normally keep cutting bar 104 in its
20 distal position (i.e., with the cutting bar's opening
106 aligned with the fixed jaw portion's channel 108),

- 42 -

unless and until wire cutting actuator 24 is activated so as to overcome the bias of spring 69.

In view of the foregoing construction, it will be seen that: (1) release lever 87 (Figs. 8-10) may be
5 activated so as to move wire follower wheel 92 away from, and toward, wire drive wheel 56 so as to permit a full wire supply cartridge 30 (Figs. 1 and 5-7) to be loaded into suturing instrument 10; (2) activating jaw closing actuator 22 will cause movable jaw portion 98
10 to close on fixed jaw portion 96; (3) activating wire advance button 20 will cause wire drive wheel 56 to advance suture wire 58 through housing 12 and shaft 16; (4) activating rotation button 26 and/or rotation button 28 will cause shaft 16 to rotate relative to
15 housing 12; and (5) activating wire cutting actuator 24 will cause cutting bar 104 to move proximally so as to sever any suture wire extending from fixed jaw portion 96.

20

- 43 -

Operation

Suturing instrument 10 may be used to apply wire suture 58 to a subject so as to effect a desired suturing operation.

5 By way of example but not limitation, and looking now at Figs. 17A-17J, suturing instrument 10 may be used to suture together two portions 110, 112 of a subject which is to be sutured. In a typical case, portions 110, 112 might comprise two sections of
10 severed tissue which need to be reattached to one another, or two pieces of previously unattached tissue which need to be attached to one another. However, one or the other of the portions 110, 112 might also
15 comprise artificial mesh or some other object being attached to tissue, etc. In addition, in a typical case, portions 110, 112 might be located relatively deep within a patient, and might be accessed during a so-called "minimally invasive", or a so-called "closed surgery", procedure; however, in other circumstances,
20 portions 110, 112 might be accessed during a conventional, or so-called "open surgery", procedure. This later situation might include procedures done at

- 44 -

the outer surface of the patient's body, i.e., where portions 110, 112 comprise surface subjects.

In any case, suturing instrument 10 is initially prepared for use by installing batteries 34 into handle 5 14, if batteries 34 are not already installed, and by installing wire supply cartridge 30 into the suturing instrument, if a cartridge 30 is not yet installed. As noted above, wire supply cartridge 30 is installed in suturing instrument 10 by (1) moving the drive barrel 10 assembly's release lever 87 to its open position (Fig. 9), so as to move wire follower wheel 92 away from wire drive wheel 56 and thereby expose the barrel assembly's central passageway 93; (2) passing the distal end of the cartridge (i.e., the distal end of wire guide 76) 15 through drive barrel assembly 80 and shaft 16 until the distal end of wire guide 76 is in communication with the channel 108 formed in fixed jaw portion 96 (Fig. 14), at which point the cartridge's wire guide support unit 74 will be positioned intermediate wire drive 20 wheel 56 and wire follower wheel 92 (Fig. 2); and (3) moving the drive barrel assembly's release lever 87 back to its closed position (Fig. 8), so as to cause

- 45 -

wire drive wheel 56 and wire follower wheel 92 to extend through the wire guide's openings 78 and engage suture wire 58.

At this point suturing instrument 10 will be ready
5 for use, with its movable jaw portion 98 being opened away from its fixed jaw portion 96, and with its cutting bar 104 being in its forward (Fig. 14) position.

Next, suturing instrument 10 has its movable jaw
10 portion 98 moved into engagement with its fixed jaw portion 96 (i.e., the jaws 96, 98 are placed in their "closed" position) by pulling jaw closing actuator 22 toward handle 14, and then the distal end of suturing instrument 10 is moved adjacent to subject portions
15 110, 112 (Fig. 17A).

In the case of a so-called closed surgical procedure, such positioning will generally involve moving the distal end of the suturing instrument through a cannula and into an interior body cavity;
20 however, it is also envisioned that one might move the distal end of the suturing instrument directly into an

- 46 -

otherwise-accessible body cavity, e.g., directly into the colon or esophagus, etc. In the case of a so-called open surgical procedure, such positioning might involve positioning the distal end of the suturing instrument adjacent to more readily accessible subject portions 110, 112.

In any case, once the distal end of suturing instrument 10 has been placed adjacent to subject portions 110, 112, jaw closing actuator 22 is released, such that biasing spring 69 (Fig. 4) will cause movable jaw portion 98 to open away from fixed jaw portion 96 (Fig. 17B). Then the distal end of suturing instrument 10 is moved so that its jaws 96, 98 straddle subject portions 110, 112, and then jaw closing actuator 22 is actuated again, by pulling jaw closing actuator 22 toward handle 14, so as to close movable jaw portion 98 against fixed jaw portion 96, whereby to capture subject portions 110, 112 (Fig. 17C).

Next, wire advance button 20 is activated so as to cause suture wire 58 to be driven forward, out of the distal end of wire guide 76, through the fixed jaw portion's channel 108, through opening 106 in cutting

- 47 -

bar 104, through the fixed jaw portion's channel extension 108A, through subject portions 110, 112, and finally through an opening 113 (Figs. 14, 15 and 17C) formed in movable jaw portion 98. Suture wire 58 is preferably advanced so that a length 58A of wire 58 extends approximately 1 centimeter out of the bottom end of movable jaw portion 98 (Fig. 17C). In this respect it will be appreciated that, as suture wire 58 leaves fixed jaw portion 96 and engages subject portions 110, 112, the fixed jaw portion's channel 108, the cutting bar's opening 106 and the fixed jaw portion's channel extension 108A will support the thin suture wire so as to enable the suture wire to penetrate subject portions 110, 112.

Once this has been done, jaw closing actuator 22 is released so as to permit movable jaw portion 98 to return to its "open" position relative to fixed jaw portion 96, and then wire advance button 20 is used to pay out additional suture wire 58 as the distal end of suturing instrument 10 is stepped back (e.g., by about a centimeter or so) from subject portions 110, 112 (Fig. 17D).

- 48 -

Then jaw closing actuator 22 is used to move jaw portion 98 back into engagement with fixed jaw portion 96 once more (Fig. 17E).

Next, left-thumb-actuated rotation button 26, or
5 right-thumb-actuated rotation button 28, is used to rotate shaft 16 and hence end effector 18. This causes suture wire 58 to twist on itself, initially creating a relatively large loop 116 (Fig. 17F) of suture wire 58 extending from subject portions 110, 112 toward
10 suturing instrument 10. However, as rotation button 26 and/or rotation button 28 is used to rotate shaft 16 (and hence end effector 18) more and more, the loop 116 of suture material will progressively close down (Fig. 17G) so as to form a tight binder for subject portions
15 110, 112. In this respect it will be appreciated that the longer the period of time that end effector 18 is rotated, the greater the amount of twisting of suture wire 58, and the greater the force holding subject portions 110, 112. In this respect it will also be
20 appreciated that suture wire 58 is preferably carefully selected with respect to its flexibility relative to the strength of subject portions 110, 112. In

- 49 -

particular, suture wire 58 is chosen so as to have a flexibility such that the suture wire will twist, and loop 116 will close down, before subject portions 110, 112 will undergo substantial deformation and/or tearing. By way of example but not limitation, in practice, it has been found that 0.005 inch diameter stainless steel wire can be used with most types of mammalian tissue such that the suture wire can be twisted closed without causing substantial deformation and/or tearing of the tissue.

Once suture wire 58 has been tightened to the desired degree, rotation of shaft 16 and end effector 18 is stopped, i.e., by releasing button 26 or button 28. Then wire cutting actuator 24 is depressed (e.g., it is pulled back toward handle 14) so as to pull cutting bar 104 proximally and thereby sever the suture wire 58 as the suture wire emerges from the fixed jaw portion's channel 108 and enters the cutting bar's opening 106 (Fig. 17H and Fig. 16). This action separates the deployed suture wire extending through subject portions 110, 112 from the suture wire

- 50 -

remaining in wire supply cartridge 30, wire guide 76 and the fixed jaw portion's channel 108.

Then wire cutting actuator 24 is released, allowing biasing spring 69 to return cutting bar 104 to return to its distal position, and then jaw closing actuator 22 is released, allowing movable jaw portion 98 to move away from fixed jaw portion 96. Suturing instrument 10 may then be removed from subject portions 110, 112, which action will pull wire length 58A from movable jaw portion 98 (Fig. 17I).

The deployed suture wire 58 may then be pressed down flat against subject portions 110, 112, or rounded into a ball, or otherwise operated upon, so as to reduce the profile of, or reduce the tendency to snag on, the deployed suture wire (Fig. 17J).

It will be appreciated that suturing instrument 10 will have application in a broad range of different suturing operations. More particularly, it will be appreciated that suturing instrument 10 will have application in both "open" and "closed" surgical procedures, with the former including, but not limited to, large entry procedures, relatively shallow

- 51 -

procedures, and surface procedures; and with the latter including, but not limited to, surgical procedures where access is gained to an interior structure through the use of a cannula, and surgical procedures where
5 access is gained directly to an internal body cavity without the use of a cannula, e.g., such as a procedure conducted within the colon or the esophagus.

It will also be appreciated that suturing instrument 10 will have application where two portions
10 of tissue must be attached to one another (e.g., where two severed pieces of tissue must be re-attached to one another, or where two separate pieces of tissue must be attached to one another, or where two sections of a
15 single piece of tissue must be approximated to one another), and where an object must be attached to the patient (e.g., where surgical mesh must be attached to the patient's abdominal wall during hernia repair surgery, etc.).

Among other things, it is believed that suturing
20 instrument 10 will have particular application in the areas of general laparoscopic surgery, general thoracic

- 52 -

surgery, cardiac surgery, general intestinal surgery, vascular surgery, skin surgery and plastic surgery.

Looking next at Figs. 18 and 19, it will be seen that where the fixed jaw portion's channel 108 is disposed so as to be substantially aligned with the center of cutting bar 104 (Fig. 18), suture wire 58 will be cut with a relatively flat leading end 58B (Fig. 19). However, it has sometimes been found helpful to provide suture wire 58 with a relatively sharp leading point. Such a leading point can help open the subject for the following portion of the suture wire. In addition, such a leading point can help the suture wire penetrate the subject with a substantially straight path, so that the suture wire will reliably enter the movable jaw portion's opening 113. To this end, it has been found that moving the fixed jaw portion's channel 108 off-center relative to cutting bar 104 (Fig. 20) will cause the leading end 58B of suture wire 58 to be formed with a relatively sharp tip 58C (Fig. 21).

It is also possible to use suturing instrument 10 to ligate a subject rather than to pass a suture

- 53 -

through the subject. For example, suturing instrument 10 might be used to ligate a blood vessel with suture wire 58. In this case, suturing instrument 10 is deployed so that suture wire 58 will pass around the far side of the subject, rather than through the subject as in the case of the suturing operation of the type described above.

By way of example but not limitation, in a typical ligating operation, movable jaw portion 98 is first opened relative to fixed jaw portion 96. Then suturing instrument 10 is positioned about the subject so that when movable jaw portion 98 is thereafter closed toward fixed jaw portion 96, the fixed jaw portion's channel 108 and the movable jaw portion's opening 113 will both lie on the far side of the subject. The movable jaw portion 98 is then closed against the fixed jaw portion 96, and suture wire 58 is passed from fixed jaw portion 96 to movable jaw portion 98, i.e., around the far side of the subject. The movable jaw portion 98 is then opened, and suture wire 58 is payed out as the instrument is stepped back from the subject. Then the movable jaw portion 98 is again closed against the

- 54 -

fixed jaw portion 96. The shaft of the instrument is then rotated so as to form, and then close down, the ligating loop. Then cutting bar 104 is activated so as to cut the ligating loop from the remainder of the suture wire still in the tool, the movable jaw member 98 is opened, and the instrument is withdrawn from the surgical site. The deployed suture wire 58 may then be pressed down flat against the subject, or rounded into a ball, or otherwise operated upon, so as to reduce the profile of, or reduce the tendency to snag on, the deployed suture wire. As will be appreciated by a person skilled in the art, where instrument 10 is to be used for ligating purposes, fixed jaw portion 96 and movable jaw portion 98 might be formed with a greater longitudinal length so as to facilitate passing the suture wire around the far side of the subject. Furthermore, movable jaw member 98 might be formed with a recess, intermediate its jaw linkage pin 100 (Fig. 15) and its opening 113, for accommodating the subject, whereby to prevent compressing the subject when movable jaw member 98 is moved into engagement with fixed jaw member 96.

- 55 -

Suture wire 58 may comprise a wire formed out of a metal or any other suitable material having the required flexibility and stiffness. By way of example but not limitation, suture wire 58 may comprise
5 stainless steel, titanium, tantalum, etc.

If desired, suture wire 58 may also be coated with various active agents. For example, suture wire 58 may be coated with an anti-inflammatory agent, or an anti-coagulant agent, or an antibiotic, or a
10 radioactive agent, etc.

Looking next at Fig. 22, it is also possible to impart ultrasound energy to the wire in order to make tissue penetration easier. More particularly, because of the small cross-sectional area of the wire and the
15 propensity for the wire to buckle when axially loaded, it is beneficial to be able to advance the wire into tissue with a minimum of load. This can be achieved by appropriately applying ultrasound energy to the wire.

A piezoelectric element 200 is placed at the
20 outside radius of the wire guide path 108 at the right angle bend in the fixed jaw portion 96 just before where the wire enters the tissue. The piezoelectric

- 56 -

element 200 vibrates at a position along this bend such that it supports the wire in completing the turn but also imparts a component of displacement in the direction of the tissue. Displacement of this kind at
5 ultrasonic frequencies, in addition to the existing wire driving means, would cause the tip of the wire to penetrate the tissue using less force. In addition to reducing the tendency for outright wire buckling, lowering the wire loads will also allow the wire
10 penetration to proceed in a straighter path.

Looking next at Fig. 23A, it will be seen that, in some circumstances, the suture wire 58 may exit fixed jaw portion 96 with a curvature, due to the fact that suture wire 58 follows a curved channel 108 in fixed
15 jaw portion 96. In some cases this curvature in the suture wire 58 may be quite modest, so that it may be effectively ignored. However, in other circumstances, this curvature might be large enough to cause the suture wire advancing out of fixed jaw portion 96 to
20 miss the target opening 113 in movable jaw portion 98. In this case the curvature in suture wire 58 can present a significant problem. However, and looking

- 57 -

now at Fig. 23B, it has been found that the profile of the cutting bar's opening 106 may be modified so as to provide a deflecting die which will counteract undesirable curvature in the suture wire and return the suture wire to a straight path as the suture wire exits fixed jaw portion 96. Alternatively, the profile of the fixed jaw portion's channel 108 may be modified, adjacent to cutting bar 104, so as to provide a similar deflecting die which will counteract undesirable curvature in the suture wire and return the suture wire to a straight path as the suture wire exits fixed jaw portion 96. Furthermore, and looking now at Fig. 23C, the mouth of the movable jaw portion's opening 113 may be enlarged to help capture a suture wire deviating from a straight path.

Looking next at Fig. 24, it will be seen that one or more legs 300 may be provided on suturing instrument 10, wherein legs 300 help stabilize the tissue during suturing.

And looking next at Fig. 25, it will be seen that a grasper 400, comprising jaws 405 and 410, may be

- 58 -

added to suturing instrument 10 to help stabilize the tissue during suturing.

If desired, the end effector 18 of suturing instrument 10 may be constructed so as to have two movable, opposing jaws, rather than one fixed jaw and one movable jaw as described above.

Also, if desired, shaft rotation motor 60 and thumb buttons 26, 28 may be configured so that depressing one button (e.g., button 26) will cause end effector 18 to rotate in one direction (e.g., clockwise), and depressing the other button (e.g., button 28) will cause end effector 18 to rotate in the opposite direction (e.g., counterclockwise).

Significantly, it has been found that the present invention has particular application in a novel procedure to address gastroesophageal reflux disease (GERD), among others.

More particularly, with this novel procedure, suturing instrument 10 may be used to gather tissue below the stomach's lower esophageal sphincter (LES) so as to improve its function and thereby reduce the symptoms of GERD. In one preferred form of the

- 59 -

invention, and looking now at Figs. 26-29, suturing
instrument 10 is inserted into the interior of a
patient's stomach so that its end effector 18 is
located adjacent to the wall of the LES (Fig. 26), jaw
5 portions 96 and 98 are used to gather together two
spaced sections 110, 112 of the wall of the LES (Fig.
27), and then suture wire 58 is used to secure
together, in the manner previously described, the
gathered-together portions of the stomach wall below
10 the LES (Figs. 28 and 29). The foregoing steps may be
repeated as many times as is necessary to adequately
gather the stomach wall below the patient's LES and
thereby improve its function and reduce the symptoms of
GERD.

15 In this respect it has also been found that it may
be useful to construct suturing instrument 10 in
certain ways, or to modify suturing instrument 10 in
certain ways, so as to facilitate its use in the
aforementioned GERD procedure, among others.

20 Thus, for example, it has been found that the
aforementioned GERD procedure may be advantageously
carried out by approaching the LES through the

- 60 -

esophagus, preferably through the working lumen of an
endoscope. To this end, suturing instrument 10 is
preferably formed so as to be flexible along its
length. This may be accomplished by forming shaft 16
5 (Figs. 1 and 14) out of a flexible material, and by
forming its internal components (e.g., jaw linkage 68,
wire cutting linkage 72 and wire guide 76) out of
flexible elements. By way of example but not
limitation, shaft 16 may be formed with a plastic,
10 metal-reinforced construction, such as a construction
of the sort used to form flexible endoscopes, and/or
with a braided polyamide construction, etc.; jaw
linkage 68 and wire cutting linkage 72 may be formed
out of flexible metal rods; and wire guide 76 may be
15 formed out of polytetrafluoroethylene (PTFE).

In this respect it should be appreciated that when
the flexible shaft 16 of suturing instrument 10 is
disposed within the working lumen of a flexible
endoscope, and the endoscope is twisted and/or bent
20 (hereinafter referred to as "twisted", "bent" and the
like) during use and the suturing instrument 10 is
independently twisted during use, there can be some

- 61 -

"whipping" of the suturing instrument and endoscope relative to one another. In other words, there can be some initial binding of one device relative to the other device as some initial degree of twisting occurs, and then the relatively uncontrolled release of that binding as the result of some further degree of twisting. This is believed to be due to the flexible nature of shaft 16 and the flexible nature of the endoscope, both of which can effectively store rotational energy. This phenomenon can sometimes make it difficult to precisely orient the angular position of one device relative to the angular position of the other device. In this respect it should be appreciated that it can be important to accurately position the jaws of suturing instrument 10 relative to the optics of the endoscope, so as to maintain a good working view of the jaws during surgery.

To this end, and looking now at Fig. 29A, there is shown a schematic outline of an alternative form of flexible shaft 16 of suturing instrument 10. This embodiment of shaft 16 is characterized by a plurality of triangular apices 16A separated by angular recesses

- 62 -

16B. Triangular apexes 16A are arranged so that they will make point contact with the inside wall of a working lumen 16C of an endoscope. This point contact provide significantly less contact area between the
5 outer surface of instrument shaft 16 and the inner wall of endoscope lumen 16C. As a result, less binding occurs between suturing instrument 10 and the endoscope, and hence less "whipping", so that the jaws of suturing instrument 10 may be more reliably
10 positioned relative to the optics of the endoscope, whereby to provide a better working view of the jaws during surgery.

Fig. 29B shows a related construction, in which shaft 16 includes a plurality of apexes 16A separated
15 by arcuate recesses 16B. Again, apexes 16A are arranged so that they will make point contact with the inside wall of a working lumen 16C of an endoscope, whereby to generate less binding between suturing instrument 10 and the endoscope, and hence less
20 "whipping" and better rotational control of the devices relative to one another during use.

- 63 -

It has also been found that the aforementioned
"whipping" problem can be reduced by the selected
disposition of the working elements located within the
flexible shaft 16 so as to maintain a symmetric
5 distribution of bending stiffness about the centerline
of the shaft for all angular positions that the shaft
might be rotated through. By way of example but not
limitation, Fig. 29C shows, in schematic form, one
possible way to dispose three working elements WE
10 within the body of flexible shaft 16, where the working
elements WE may comprise jaw linkage 68, wire cutting
linkage 72 and wire guide 76. In the arrangement shown
in Fig. 29C, the working elements WE are disposed in a
relatively linear disposition, and this configuration
15 has been found to be relatively susceptible to the
aforementioned "whipping" problem if the working
elements WE have different stiffnesses than the
surrounding shaft material. On the other hand, in Fig.
29D the working elements WE are arranged with a more
20 symmetrical distribution, and this latter configuration
has been found to be relatively resistant to the
aforementioned "whipping" problem.

- 64 -

It is also possible to form a flexible shaft 16 in other ways. Thus, for example, and looking next at Fig. 29E, a portion of shaft 16 may be removed, e.g., at A, so as to leave a smaller, flexible spine B

5 connecting a distal section C with a proximal section D. If desired, spine B may be formed integral with, and out of the same material as, distal section C and proximal section D; alternatively, spine section B may be formed out of another material, e.g., Nitinol.

10 Furthermore, if desired, the connecting section B could be located along the center axis of shaft 16, e.g., by making it out of a separate piece of material connected to both distal section C and proximal portion D. This latter construction can be particularly advantageous in

15 that it can be relatively stiff in torsion as to transmit torque, yet flexible in bending along its length.

Furthermore, in using suturing instrument 10 in the aforementioned GERD procedure, it has been found

20 that the LES can frequently be difficult to grasp and draw together, due to (i) the angle of attack to the tissue, (ii) the slippery nature of the tissue, and

- 65 -

(iii) the variable tones of the tissue. As a result, it has also been found that it can be helpful to provide two movable jaw portions for gripping the tissue.

5 More particularly, and looking now at Figs. 30-39, two movable jaw portions 96A, 98A may be provided at the distal end of shaft 16. Jaw portions 96A, 98A are pivotally pinned, via pivot pins 100A and 100B, respectively, to an outer yoke 16A secured to the
10 distal end of shaft 16 (Fig. 31). At the same time, jaw portions 96A, 98A are also pivotally pinned, via a pivot pin 100C riding in a slot 100D, to an inner yoke 16B (Fig. 33). Inner yoke 16B is movably disposed within outer yoke 16A and is secured to the end of jaw
15 linkage 68A. As a result of this construction, when inner yoke 16B is moved distally by jaw linkage 68A, jaw portions 96A, 98A will open relative to one another (Fig. 31); and when inner yoke 16B is moved proximally by jaw linkage 68A, jaw portions 96A, 98A will close
20 together (Fig. 37). The foregoing construction is highly advantageous for several reasons, among others:
(i) by providing two movable jaw portions, the mouth of

- 66 -

the suturing instrument can be enlarged so as to facilitate gripping and drawing together tissue, e.g., such as in the aforementioned GERD procedure, and (ii) by using a single, movable inner yoke 16B to open and close jaw portions 96A, 98A pinned to a fixed outer yoke 16A, the two jaw portions can be made to reliably open and close to a corresponding and symmetrical extent, thereby ensuring uniform mouth operation at all times.

In addition to the foregoing, jaw portions 96A, 98A are preferably provided with offset distal teeth (or fangs) 96B, 98B, respectively (Fig. 30). These teeth (or fangs) 96B, 98B enhance the ability of the jaw portions to grip tissue, particularly hard-to-grip tissue such as the LES during the aforementioned GERD procedure.

Inasmuch as jaw portions 96A, 98A both move, it can also be advantageous to modify certain aspects of the suturing instrument from the construction previously disclosed. More particularly, with the suturing instrument disclosed above, jaw portion 96, which delivers suture wire 58 to the tissue, is fixed

- 67 -

relative to shaft 16, and wire guide 76 extends linearly into jaw portion 96 and preferably confronts a stop shoulder (Fig. 14). However, with the embodiment disclosed in Figs. 30-39, both jaw portion 96A and jaw portion 98A move relative to shaft 16. As a result, with the construction of Figs. 30-39, it is preferred that the distal end of wire guide 76A (Fig. 39) terminate in jaw portion 96A in a slightly different manner so that suture wire 58 can be reliably guided into the wire guide path in jaw portion 96A. At the same time, inasmuch as it is desirable to increase the radius of curvature imposed on suture wire 58, it is preferred that wire guide 76A be outboard of pivot pin 100A, so that wire guide 76A can "cut the corner" when jaw portion 96A is in its open position (Fig. 33). To this end, since the distal end of wire guide 76A may move slightly relative to jaw portion 96A depending on the pivotal position of jaw portion 96A, it is preferred that the distal end of wire guide 76A be provided with a flange 76B (Fig. 33) which is received in a slot 96C which is formed in jaw portion 96A,

- 68 -

whereby wire guide 76A can be attached to jaw portion 96A with a floating engagement.

In order to prevent cutting bar 104 and/or wire cutting linkage 72 from impeding the opening and/or closing of jaw portion 96A, it is preferred that cutting bar 104 and wire cutting linkage 72 be sized so that they can both be fully withdrawn from jaw portion 96A when cutting bar 104 is in its withdrawn (i.e., proximal) position. And in one preferred form of the invention, cutting bar 104 and its associated wire cutting linkage 72 are replaced by a single cutting rod 104A (Figs. 37 and 38) which extends from housing 12 to the end of shaft 12. The distal end of cutting rod 104A is used to selectively intrude across the wire guide path formed in jaw portion 96A so as to sever suture wire deployed from the suturing instrument. Cutting rod 104A is preferably formed out of a flexible material, such that cutting rod 104A can extend into jaw portion 96A even when intervening tissue should prevent full closure of jaw portion 96A and 98A.

In the aforementioned GERD procedure, it has been found that where the LES is accessed through the

- 69 -

esophagus, wire must be driven a fairly long distance, e.g., from an area proximal to the proximal end of the endoscope (typically located a significant distance from the patient's mouth) to an area distal to the distal end of the endoscope (typically located at the LES). In practice, this is typically a distance of approximately 3 feet for a gastroscope (and up to 5 feet long for a colonoscope, when doing colon procedures, see below). However, it has been found that it can be difficult to drive the suture wire such a long distance. This is because the suture wire is typically chosen for its penetrating, twisting and cutting characteristics, and this typically means using relatively soft wire, e.g., 316L stainless steel wire having a tensile strength of 160 kpsi. Thus, in one form of the invention, it has been found helpful to supply suture wire 58A (Fig. 40) of two differing characteristics: (i) a softer distal wire portion 58B optimized for tissue penetration, twisting and cutting, and a harder proximal wire portion 58C optimized for driving. By way of example, while distal wire portion 58B might comprise 316L stainless steel with a tensile

- 70 -

strength of 160 kpsi, proximal wire portion 58C might
comprise 304 stainless steel with a tensile strength of
430 kpsi. Distal wire portion 58B might be
incorporated with wire supply cartridge 30 during
5 manufacture, or distal wire portion 58B might be added
to wire supply cartridge 30 and/or suturing instrument
10 after proximal wire portion 58C has been installed
in wire supply cartridge 30. Distal wire portion 58B
may or may not be secured to proximal wire portion 58C.

10 It should also be appreciated that while suturing
instrument 10 uses the aforementioned drive barrel
assembly 80 (Fig. 8) to drive suture wire 58 (or suture
wire 59A), other apparatus may be used to drive the
suture wire, e.g., a wire drive mechanism such as is
15 disclosed in pending U.S. Patent Applications Serial
No. 10/051,322, filed 01/18/02 by Frederic P. Field et
al. for SURGICAL SUTURING INSTRUMENT AND METHOD OF USE
(Attorney's Docket No. ONUX-13); or a wire drive
mechanism such as is disclosed in pending U.S. Patent
20 Application Serial No. 10/039,601, filed 10/19/01 by
Frederic P. Field et al. for SURGICAL SUTURING
INSTRUMENT AND METHOD OF USE (Attorney's Docket No.

- 71 -

ONUX-17); or a wire drive mechanism such as is disclosed in pending U.S. Patent Application Serial No. 10/352,600, filed 01/28/03 by Frederic P. Field et al. for SURGICAL SUTURING INSTRUMENT AND METHOD OF USE
5 (Attorney's Docket No. ONUX-22 CON); or any other wire drive mechanism consistent with the present invention. The three aforementioned patent applications are hereby incorporated herein by reference.

Looking next at Figs. 41-55, there is shown the proximal end of another suturing instrument 10 also
10 formed in accordance with the present invention. The suturing instrument 10 shown in Figs. 41-55 is particularly well suited for use in the aforementioned GERD procedure, and is substantially the same as the
15 suturing instrument 10 described above except as will be discussed below. More particularly, the suturing instrument 10 shown in Figs. 41-55 has a somewhat different handle assembly and controls for actuating the shaft's working elements WE (i.e., jaw linkage 68,
20 wire cutting linkage 72 and wire guide 76), and preferably uses the two movable jaw portions 96A, 98A shown in Figs. 30-39.

- 72 -

Looking next at Figs. 41 and 42, the suturing instrument 10 shown in Figs. 41-55 comprises a handle 900 which carries the instrument's user controls as will hereinafter be described and from which extends shaft 16. Inasmuch as the suturing instrument 10 is intended to be used in conjunction with an endoscope, and inasmuch as it can be important to lock the longitudinal position of the suturing instrument relative to the endoscope (e.g., to permit proper viewing of the jaws through the limited depth of field typically available with the endoscope's optics), the suturing instrument preferably includes a movable scope mount 902 for selectively locking (Fig. 42) and unlocking (Fig. 41) the suturing instrument to the endoscope.

Looking next at Figs. 43-46, suturing instrument 10 also comprises a rotation knob 904 at its proximal end for manually rotating the two movable jaw portions 96A, 98A to a desired orientation relative to handle 900, and a trigger 906 for moving a trigger linkage 908, whereby the two movable jaw portions 96A, 98A may

- 73 -

be moved between an open position (Figs. 43 and 44) and a closed position (Figs. 45 and 46).

Looking next at Figs. 47-53, there is shown a wire drive assembly 910. Wire drive assembly 910 comprises a push lever 912 which is connected to a sliding cage 914. Sliding cage 914 includes a window 916 having a flexible finger 918 movably positioned within window 916 so as to selectively engage suture wire 58. A supply of suture wire 58 is preferably wound in a recess 920 formed in sliding cage 914. As a result of this construction, when push lever 912 advances sliding cage 914 distally (i.e., right to left as seen in Fig. 53) within handle 900, finger 918 moves into secure engagement with the suture wire 58, whereby to advance suture wire 58 distally. However, when push lever 912 retracts sliding cage 914 proximally within handle 900, finger 918 will yield so that the finger moves out of binding engagement with the suture wire, thus imparting no motion to suture wire 58 during the sliding cage's return stroke.

Wire drive assembly 910 also comprises a stationary cage 922 disposed in handle 900. Stationary

- 74 -

cage 922 includes a window 924 having a flexible finger 926 secured to the stationary cage 922 and extending through window 924. As a result of this construction, when sliding cage 914 advances suture wire 58 distally, flexible finger 926 will move distally within window 924, so that the flexible finger 926 moves out of binding engagement with suture wire 58, thereby allowing suture wire 58 to advance unimpeded by stationary cage 922. However, when sliding cage 914 is moved through its return stroke, any proximal movement of suture wire 58 will cause the stationary cage's flexible finger 926 to move into tighter engagement with suture wire 58 and prevents proximal movement of the suture wire.

Thus it will be seen that sliding cage 914 and stationary cage 922 together act as a one-way wire advancement mechanism, permitting suture wire 58 to be advanced distally within shaft 16 but preventing proximal motion.

Looking next at Figs. 54 and 55, suturing instrument 10 also comprises a cutbar actuator 928 that is connected to wire cutting linkage 72. Moving cutbar

- 75 -

actuator 928 proximally (Fig. 54) causes cutting bar 104 to be retracted into its non-cutting position, and moving cutbar actuator 928 distally (Fig. 55) causes cutting bar 104 to move distally to its wire cutting position.

Suturing instrument 10 preferably operates as follows.

First, with suturing instrument 10 in the condition shown in Figs. 41 and 46 and (i.e., with scope mount 902 in the open position and with trigger 906 depressed so that the two movable jaw portions 96A, 98A are closed), the distal end of the suturing instrument is advanced into the working lumen of the endoscope. Then the suturing instrument's scope mount 902 is moved to its locked position so as to lock the suturing instrument in proper position (Fig. 42) relative to the endoscope. Then the endoscope and suturing instrument are manipulated until the two movable jaw portions 96A, 98A are placed adjacent to the tissue which is to be sutured. Then the two movable jaw portions 96A, 98A are opened (Fig. 44), the jaws are advanced to the tissue, and then the two jaws

- 76 -

are closed so as to gather together the tissue which is to be sutured. Then push lever 912 is moved repeatedly through its drive stroke, thus causing sliding cage 914 to also move repeatedly through its drive stroke, whereby suture wire 58 is advanced distally so that the suture wire is advanced from one jaw to the other, and through the tissue captured therebetween.

The two jaw portions 96A, 98A are then opened, and suture wire 58 is payed out as the instrument is stepped back from the subject. Then the movable jaw portions 96A, 98A are closed again. The shaft of the instrument is then rotated using rotation knob 904 so as to form, and then close down, the tightening loop. Then cutting bar 104 is activated using cutbar actuator 928 so as to cut the tightening loop from the remainder of the suture wire still in the tool, the two jaw members 98 are opened, and the instrument is withdrawn from the surgical site. The deployed suture wire 58 may then be pressed down flat against the subject, or rounded into a ball, or otherwise operated upon, so as to reduce the profile of, or reduce the tendency to snag on, the deployed suture wire.

- 77 -

Thereafter, the foregoing process may be repeated, until the desired number of suture loops has been deployed or until the supply of suture wire 416 is exhausted.

5 The foregoing constructions and/or modifications have been found to be particularly advantageous for effecting the aforementioned GERD procedure, particularly when accessing the LES through the esophagus. However, it should also be appreciated that
10 one or more of these constructions and/or modifications may also be applicable to other surgical procedures including, but not limited to, a gastric bypass procedure; hemostasis for peptic ulcer disease; closing perforations within the gastrointestinal tract; fixing
15 stents within the gastrointestinal tract or elsewhere in the body; fixing GERD monitoring apparatus in place within the gastrointestinal tract; closing endoscopic mucosal resection (EMR) sites within the stomach and/or the colon; and in other surgical procedures which will
20 be obvious to those skilled in the art in light of the present disclosure.

- 78 -

Modifications

It will be appreciated by those skilled in the art that numerous modifications and variations may be made to the above-disclosed embodiments without departing
5 from the spirit and scope of the present invention.

- 79 -

What Is Claimed Is:

1. A suturing device comprising:

a housing;

5 a shaft extending distally from said housing, at least a portion of said shaft being flexible, and said shaft having an outer surface characterized by a plurality of peaks and a plurality of troughs, whereby to make point contact with the working lumen of an
10 endoscope;

a pair of opposing jaws located at a distal end of said shaft;

a suture drive mechanism located in said housing and adapted to advance suture material through said
15 shaft, through one of said jaws, through a subject to be sutured, and into the other jaw; and

a jaw rotation mechanism located in said housing and adapted to rotate said jaws so as to secure the suture material to the subject.

20

- 80 -

2. A suturing device according to claim 1 wherein said shaft is formed out of a flexible material.

5 3. A suturing device according to claim 1 wherein said shaft is formed out of a plastic material.

10 4. A suturing device according to claim 3 wherein said plastic material is reinforced with a metal material.

15 5. A suturing device according to claim 1 wherein said shaft is made more flexible by removing a portion of said shaft.

20 6. A suturing device according to claim 1 wherein said shaft comprises a distal section, a proximal section and a flexible spine section connecting said distal section to said proximal section.

- 81 -

7. A suturing instrument according to claim 6 wherein said spine section is located on the periphery of said shaft.

5 8. A suturing instrument according to claim 6 wherein said spine section is located along the center axis of said shaft.

10 9. A suturing device according to claim 1 wherein said device further comprises a cutting mechanism adapted for selective movement through said one of said jaws for engagement with, and severing of, suture material extending through said one of said jaws.

15

10. A suturing device according to claim 9 wherein said cutting mechanism is withdrawn from said one of said jaws when it is not engaged in severing the suture material.

20

- 82 -

11. A suturing device according to claim 9 wherein said cutting mechanism comprises a cutting rod formed out of a flexible material.

5 12. A suturing device according to claim 9 wherein said one of said jaws is pivotally connected to said distal end of said shaft by a pivot pin, wherein said device further comprises a wire guide for supporting the suture wire between said suture drive
10 mechanism and said one of said jaws, and further wherein said wire guide is positioned outboard of said pivot pin.

15 13. A suturing mechanism according to claim 9 wherein the distal end of said wire guide is attached to said one of said jaws by a floating mount.

20 14. A suturing device comprising:
a housing;
a shaft extending distally from said housing, at least a portion of said shaft being flexible;

- 83 -

a pair of movable jaws pivotally connected to the distal end of said shaft in opposing relation such that said jaws can open and close relative to one another, said opposing jaws being operated by a jaw actuating mechanism extending through said shaft;

a suture drive mechanism located in said housing and adapted to advance suture material through said shaft, through one of said jaws, through a subject to be sutured, and into the other jaw;

a jaw rotation mechanism located in said housing and adapted to rotate said jaws so as to secure the suture material to the subject; and

a cutting mechanism adapted for selective movement through said one of said jaws for engagement with, and severing of, suture material extending through said one of said jaws, said cutting mechanism being operated by a cutter actuating mechanism extending through said shaft; and

further wherein said jaw actuating mechanism, said suture material and said cutter actuating mechanism are disposed substantially symmetrically within said shaft.

- 84 -

15. A suturing device according to claim 14 wherein said cutting mechanism is withdrawn from said one of said jaws when it is not engaged in severing the suture material.

5

16. A suturing device according to claim 14 wherein said cutting mechanism comprises a cutting rod formed out of a flexible material.

10

17. A suturing device according to claim 14 wherein said one of said jaws is pivotally connected to said distal end of said shaft by a pivot pin, wherein said device further comprises a wire guide for supporting the suture wire between said suture drive mechanism and said one of said jaws, and further wherein said wire guide is positioned outboard of said pivot pin.

15

20

18. A suturing mechanism according to claim 14 wherein the distal end of said wire guide is attached to said one of said jaws by a floating mount.

- 85 -

19. A suturing device comprising:

a housing;

a shaft extending distally from said housing;

5 a pair of opposing jaws located at a distal end of
said shaft;

a suture drive mechanism located in said housing
and adapted to advance suture material through said
shaft, through one of said jaws, through a subject to
be sutured, and into the other jaw, said wire advancing
10 actuator comprising a sliding cage adapted for distal
and proximal movement within said handle, said sliding
cage comprising a flexible finger, and further wherein
(1) distal movement of said sliding cage causes said
finger to bindingly engage said suture wire and drive
15 it distally, and (2) proximal movement of said sliding
cage causes said finger to disengage from binding
engagement with said suture wire;

a jaw rotation mechanism located in said housing
and adapted to rotate said jaws so as to secure the
20 suture material to the subject; and

a source of suture material located in the device.

- 86 -

20. A suturing instrument according to claim 19 wherein said wire advancing actuator further comprises a stationary cage, said stationary cage comprising a flexible finger, and further wherein (1) proximal
5 movement of said suture wire causes said flexible finger to bindingly engage said suture wire and hold it stationary, and (2) distal movement of said suture wire causes said flexible finger to disengage from binding engagement with said suture wire.

10

21. A method for treating gastroesophageal reflux disease (GERD), comprising:

providing a suturing device comprising:

a housing;

15

a shaft extending distally from said housing, at least a portion of said shaft being flexible, and said shaft having an outer surface characterized by a plurality of peaks and a plurality of troughs, whereby to make point contact with the working lumen of an
20 endoscope;

a pair of opposing jaws located at a distal end of said shaft;

- 87 -

a suture drive mechanism located in said housing and adapted to advance suture material through said shaft, through one of said jaws, through a subject to be sutured, and into the other jaw; and

5 a jaw rotation mechanism located in said housing and adapted to rotate said jaws so as to secure the suture material to the subject;

10 advancing the distal end of the suturing device into a patient's stomach so that the distal end of the suturing device is adjacent to the wall of the stomach below the lower esophageal sphincter (LES);

gathering together portions of the stomach wall below the LES with the pair of opposing jaws;

15 operating the suture drive mechanism so as to advance suture material through the gathered-together portions of the stomach wall; and

20 operating the jaw rotation mechanism so as to secure the suture material to the subject and thereby secure together the gathered-together portions of the stomach wall.

- 88 -

22. A method according to claim 21 wherein the suturing device is advanced into the patient's stomach through the esophagus.

5 23. A method according to claim 21 wherein the suturing device is advanced into the patient's stomach through an endoscope.

10 24. A method for treating gastroesophageal reflux disease (GERD), comprising:

 providing a suturing device comprising:

 a housing;

 a shaft extending distally from said housing;

15 a pair of opposing jaws located at a distal end of said shaft, said opposing jaws being operated by a jaw actuating mechanism extending through said shaft;

20 a suture drive mechanism located in said housing and adapted to advance suture material through said shaft, through one of said jaws, through a subject to be sutured, and into the other jaw; and

- 89 -

a jaw rotation mechanism located in said housing and adapted to rotate said jaws so as to secure the suture material to the subject; and

5 a cutting mechanism adapted for selective movement through said one of said jaws for engagement with, and severing of, suture material extending through said one of said jaws, said cutting mechanism being operated by a cutter actuating mechanism extending through said shaft; and

10 further wherein said jaw actuating mechanism, said suture material and said cutter actuating mechanism are disposed substantially symmetrically within said shaft;

15 advancing the distal end of the suturing device into a patient's stomach so that the distal end of the suturing device is adjacent to the wall of the stomach below the lower esophageal sphincter (LES);

gathering together portions of the stomach wall below the LES with the pair of opposing jaws;

20 operating the suture drive mechanism so as to advance suture material through the gathered-together portions of the stomach wall; and

- 90 -

operating the jaw rotation mechanism so as to secure the suture material to the subject and thereby secure together the gathered-together portions of the stomach wall.

5

25. A method for treating gastroesophageal reflux disease (GERD), comprising:

providing a suturing device comprising:

a housing;

10

a shaft extending distally from said housing, at least a portion of said shaft being flexible;

a pair of opposing jaws located at a distal end of said shaft;

15

a suture drive mechanism located in said housing and adapted to advance suture material through said shaft, through one of said jaws, through a subject to be sutured, and into the other jaw, said wire

20

advancing actuator comprising a sliding cage adapted for distal and proximal movement within said handle, said sliding cage comprising a flexible finger, and further wherein (1) distal movement of said sliding cage causes said finger to bindingly engage said suture

- 91 -

wire and drive it distally, and (2) proximal movement of said sliding cage causes said finger to disengage from binding engagement with said suture wire; and

5 a jaw rotation mechanism located in said housing and adapted to rotate said jaws so as to secure the suture material to the subject;

10 advancing the distal end of the suturing device into a patient's stomach so that the distal end of the suturing device is adjacent to the wall of the stomach below the lower esophageal sphincter (LES);

gathering together portions of the stomach wall below the LES with the pair of opposing jaws;

15 operating the suture drive mechanism so as to advance suture material through the gathered-together portions of the stomach wall; and

operating the jaw rotation mechanism so as to secure the suture material to the subject and thereby secure together the gathered-together portions of the stomach wall.

20

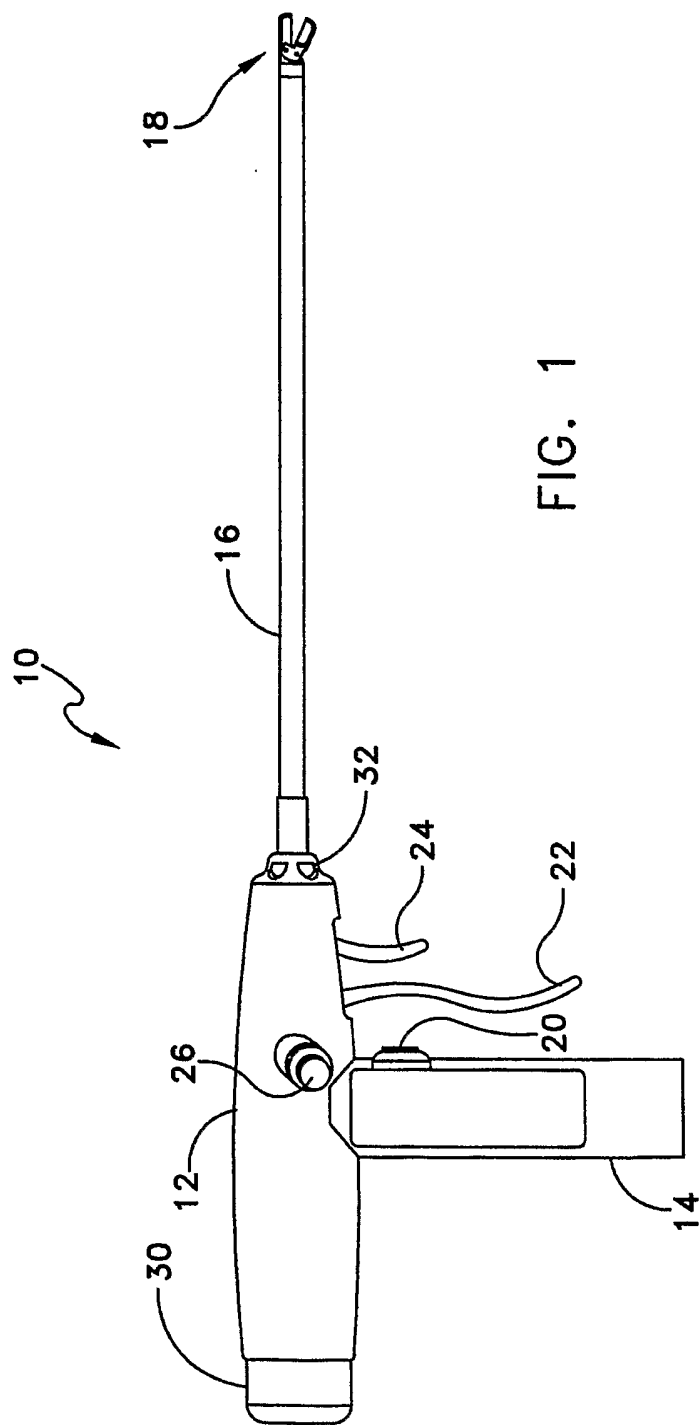

FIG. 1

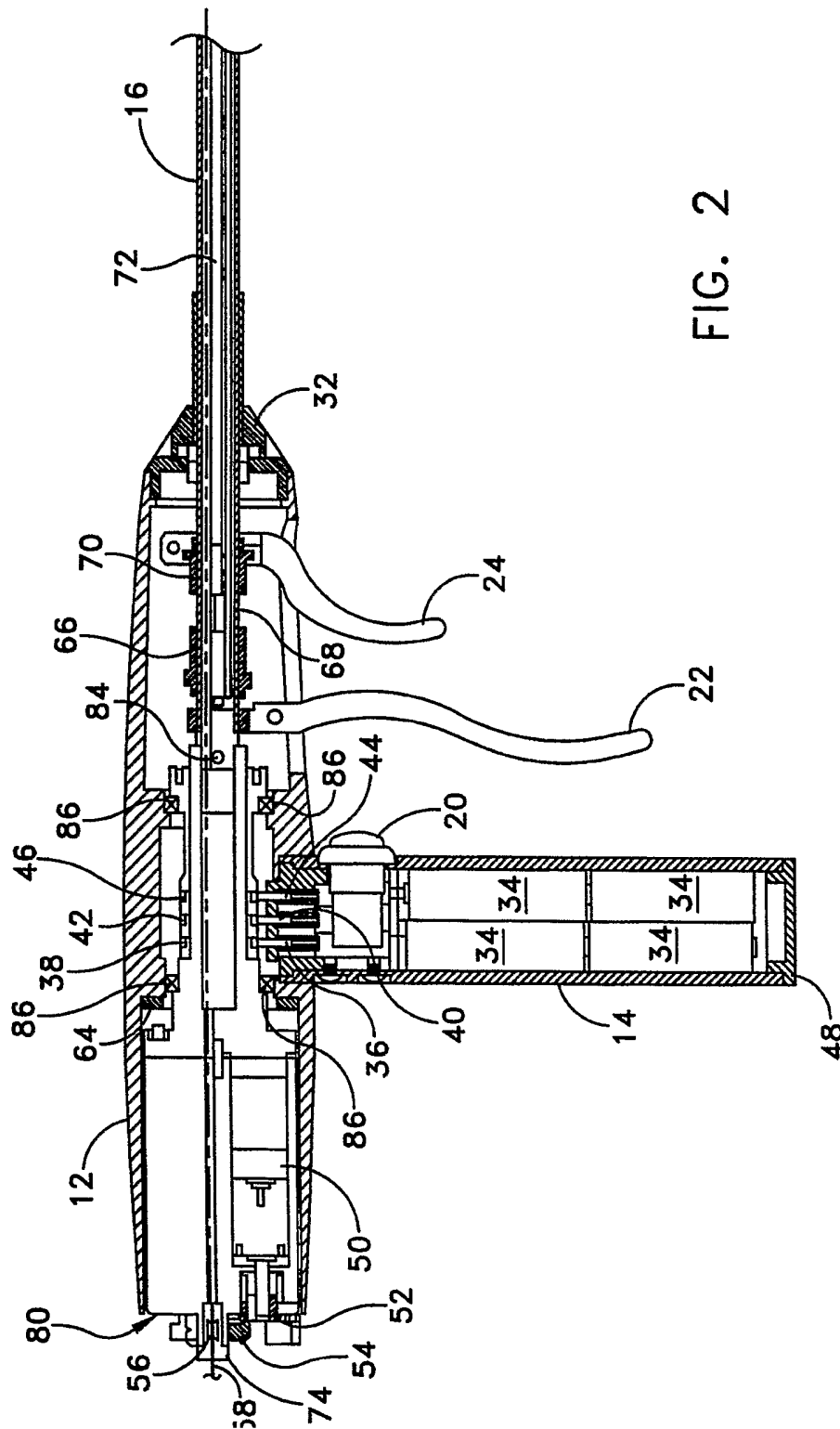

FIG. 2

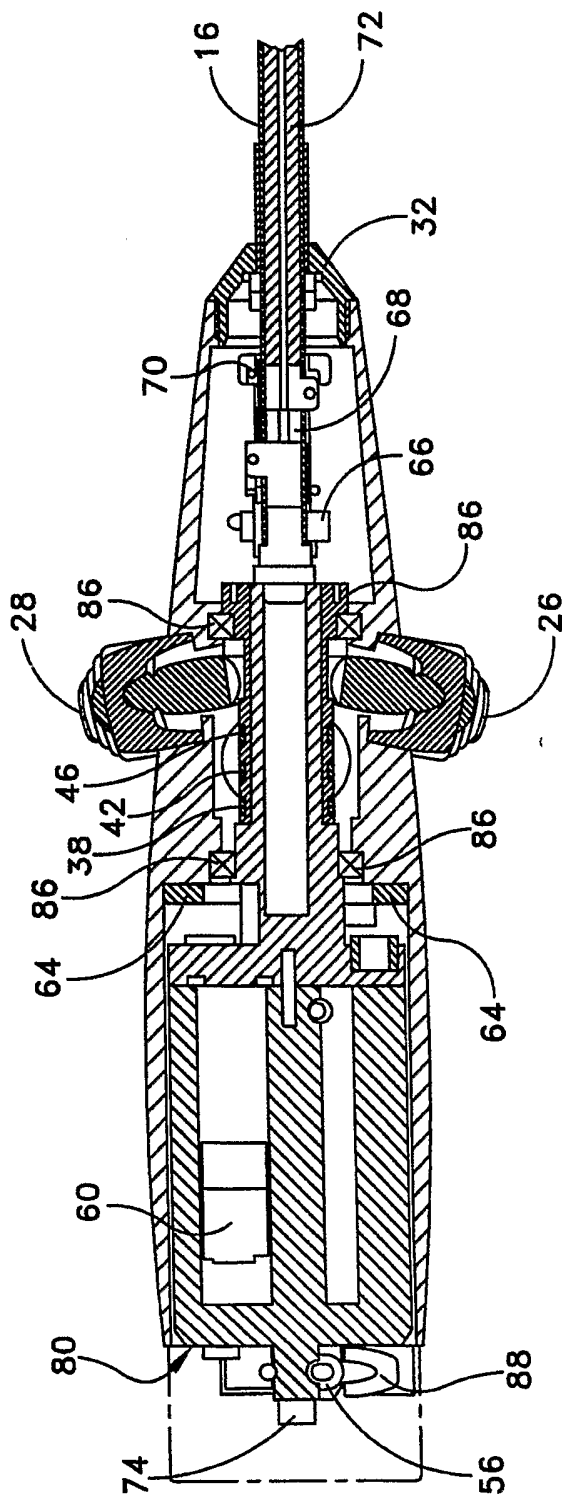

FIG. 3

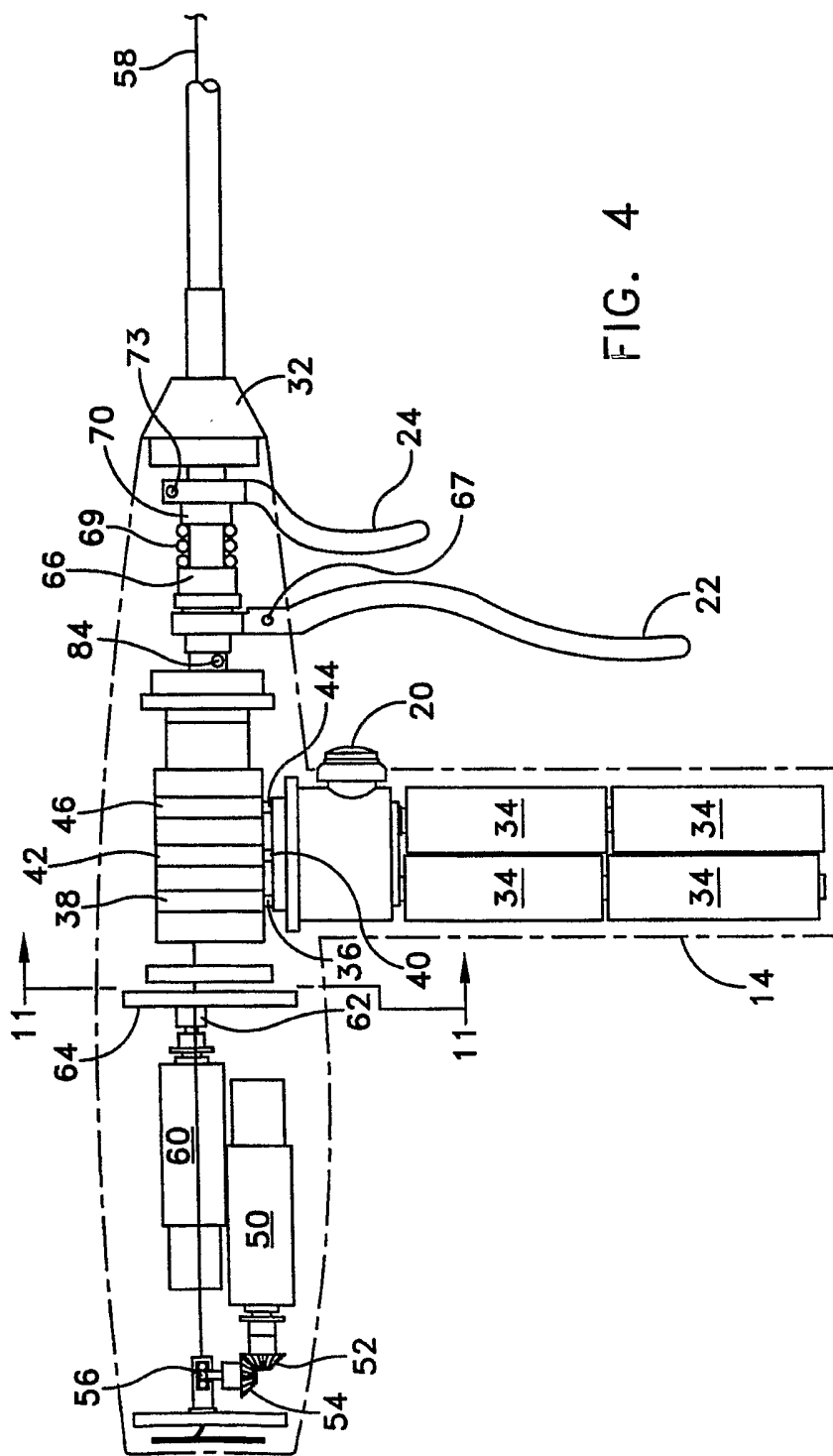

FIG. 4

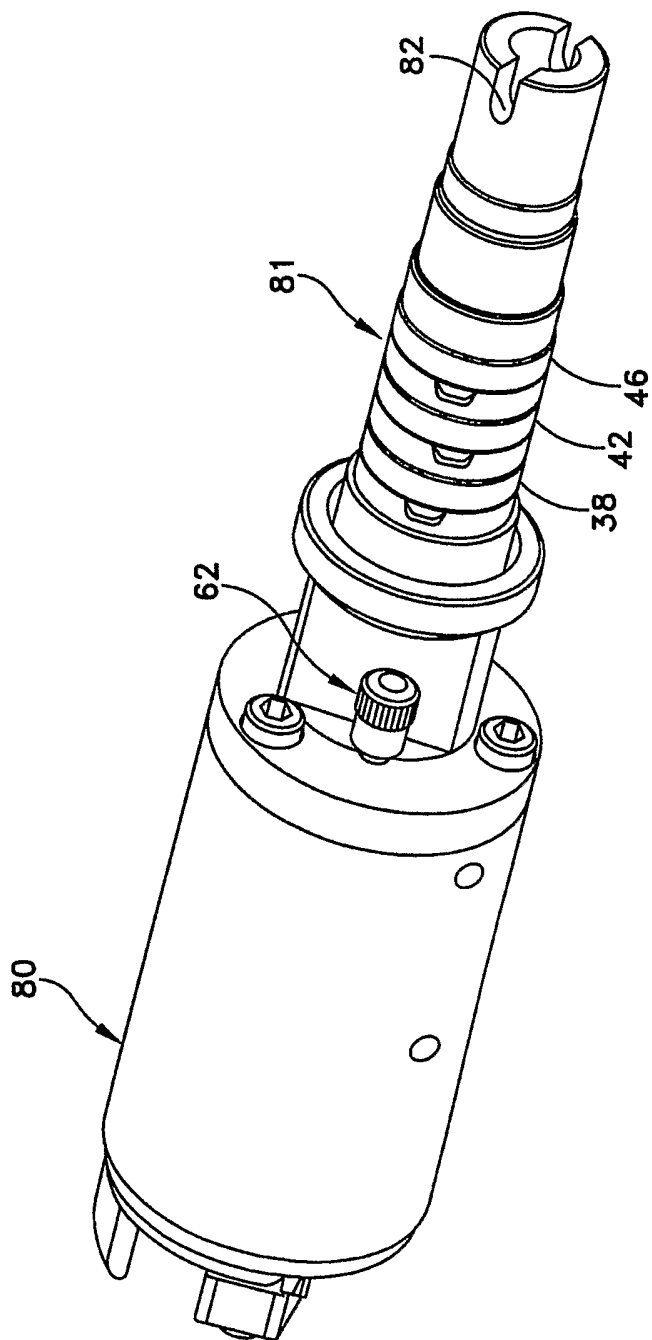

FIG. 4A

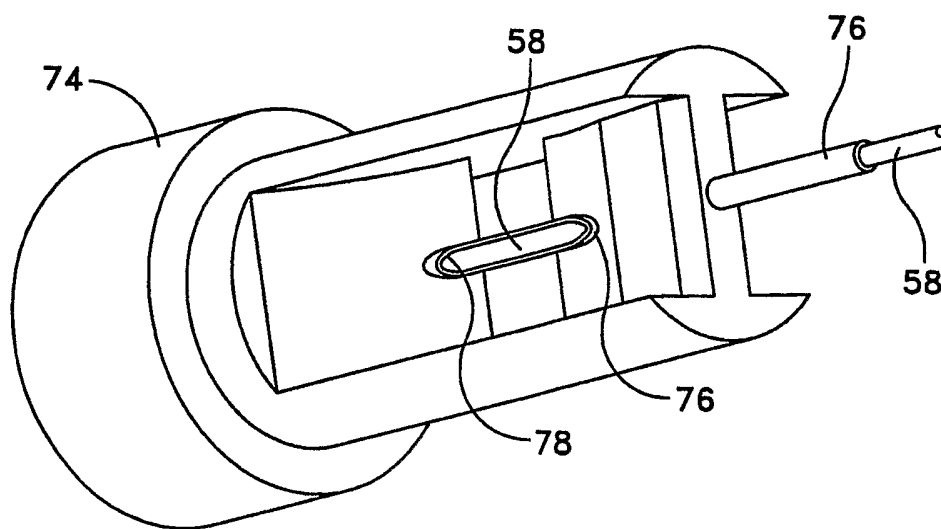

FIG. 5

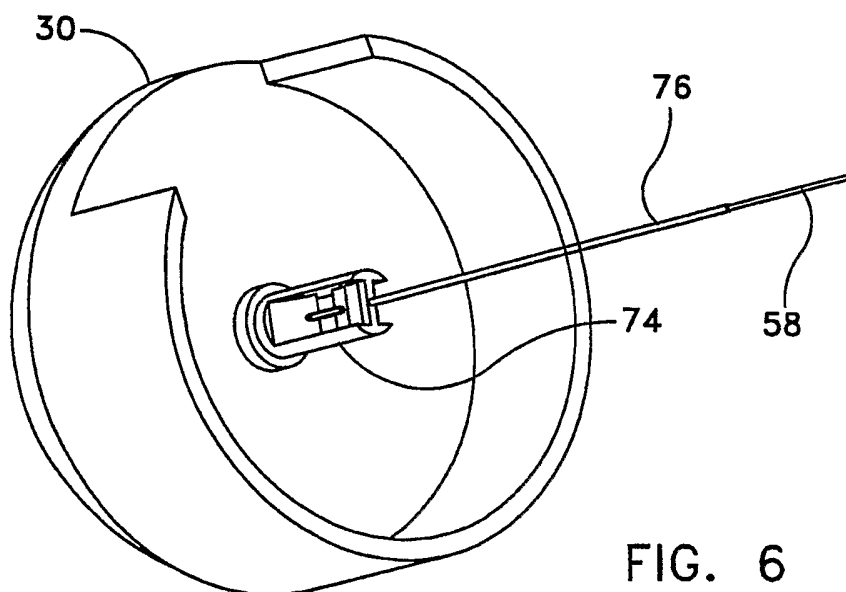
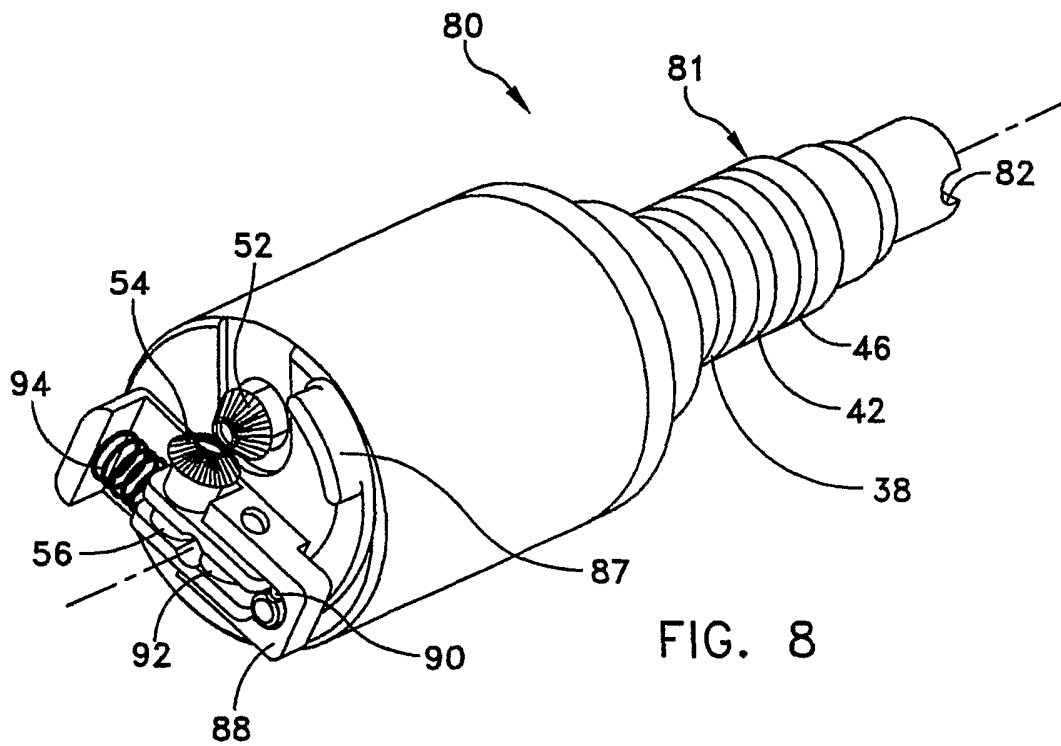
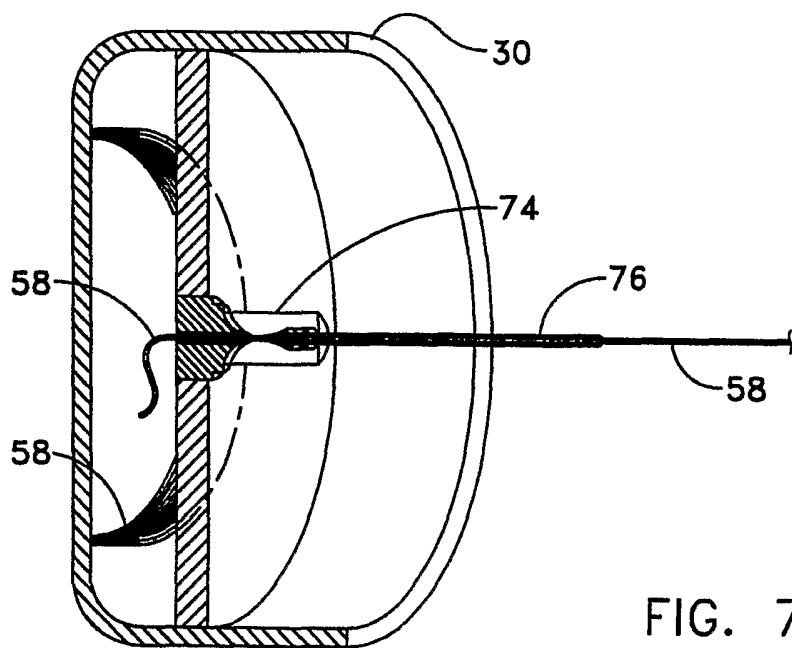

FIG. 6



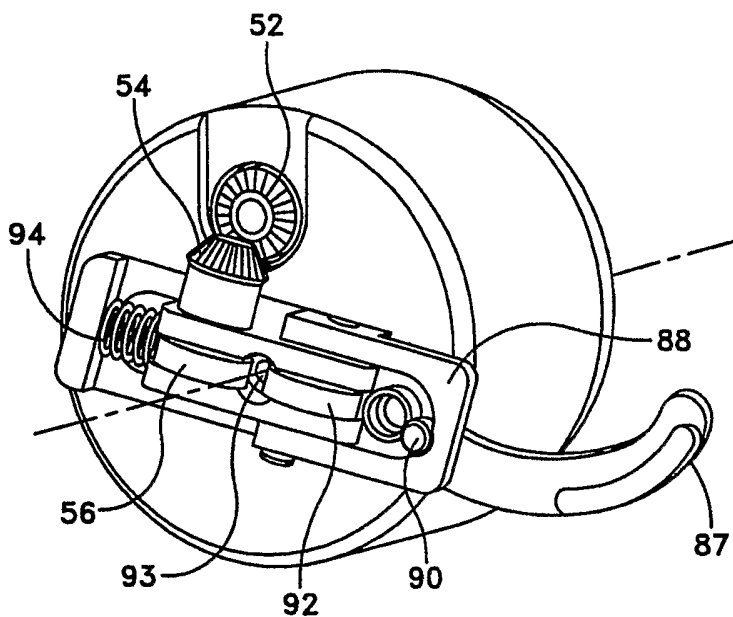

FIG. 9

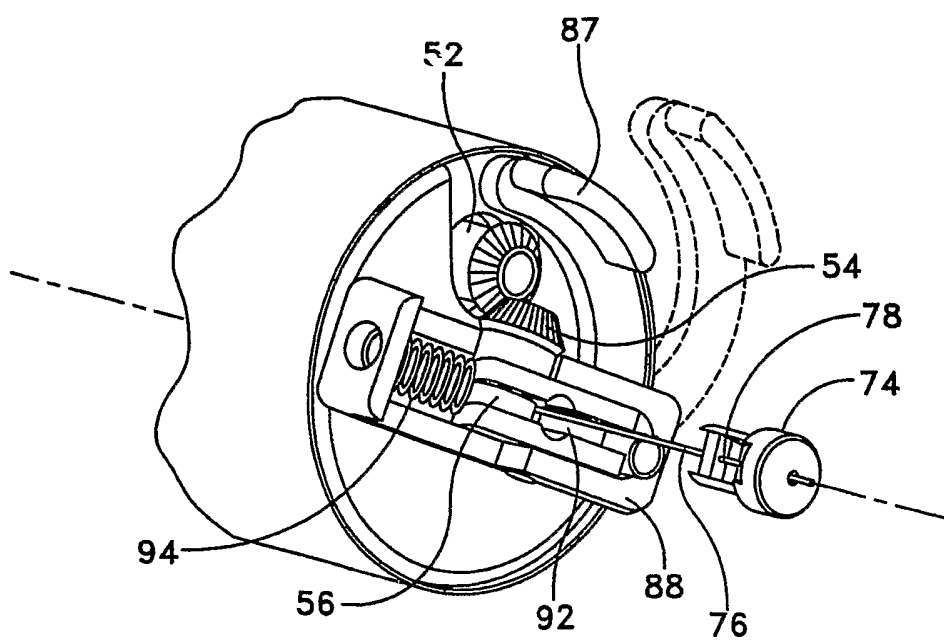

FIG. 10

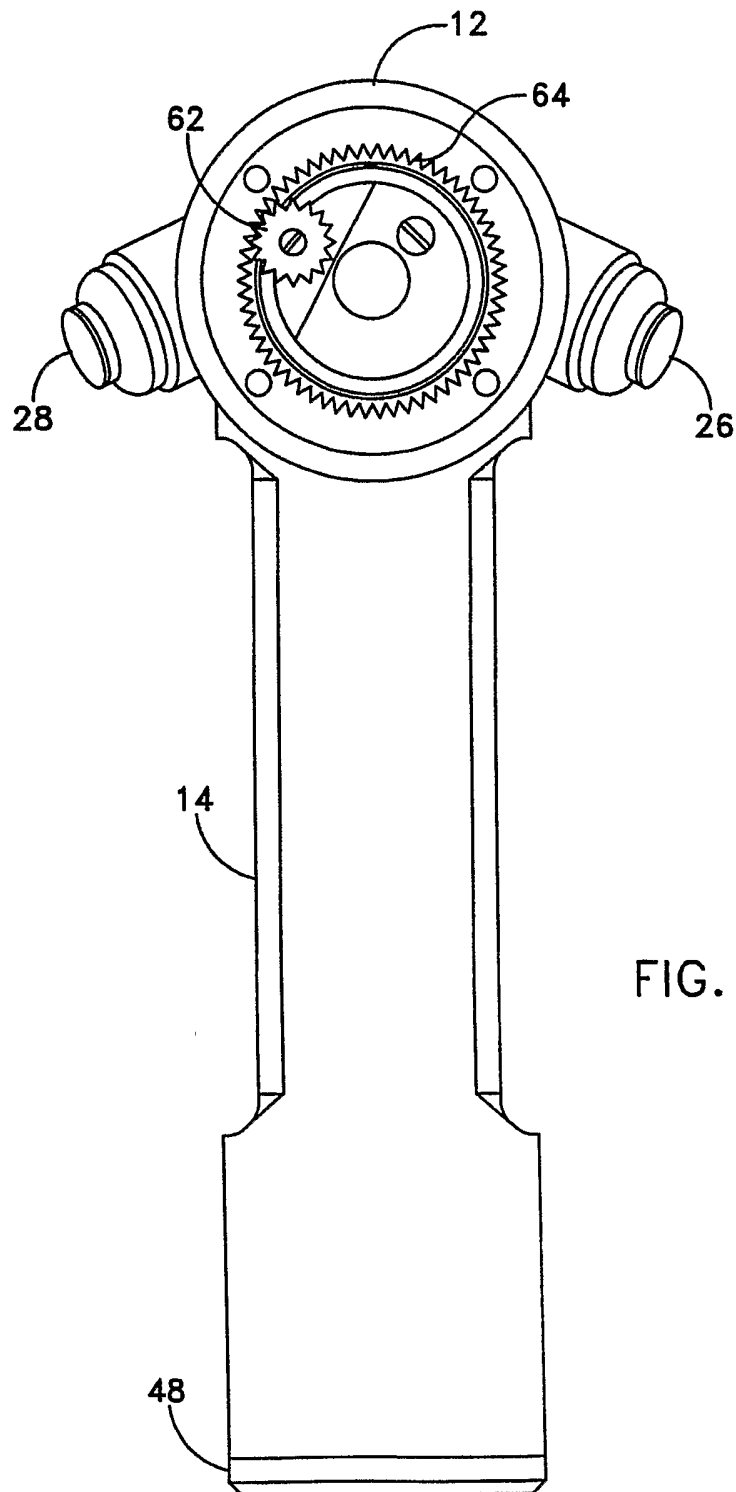

FIG. 11

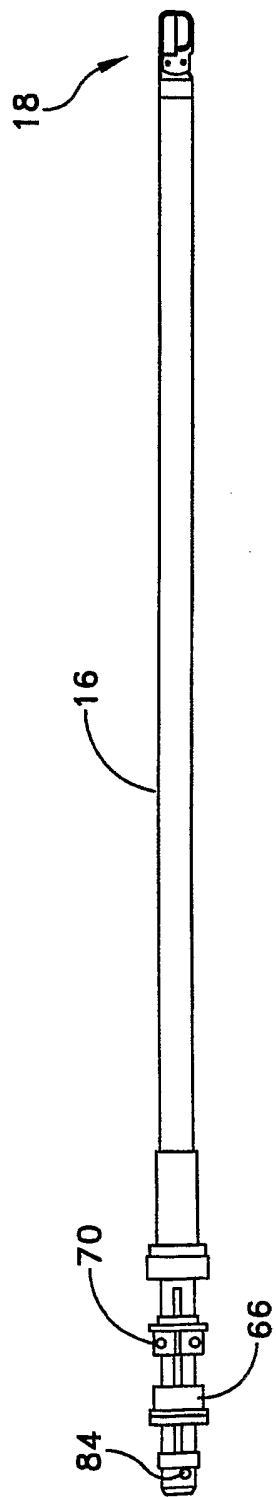

FIG. 12

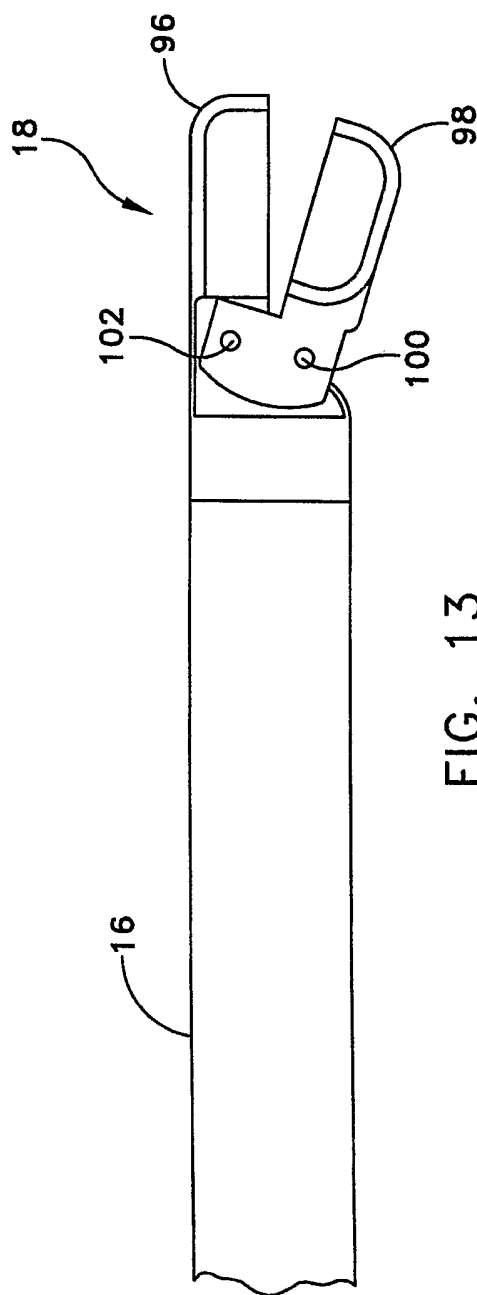

FIG. 13

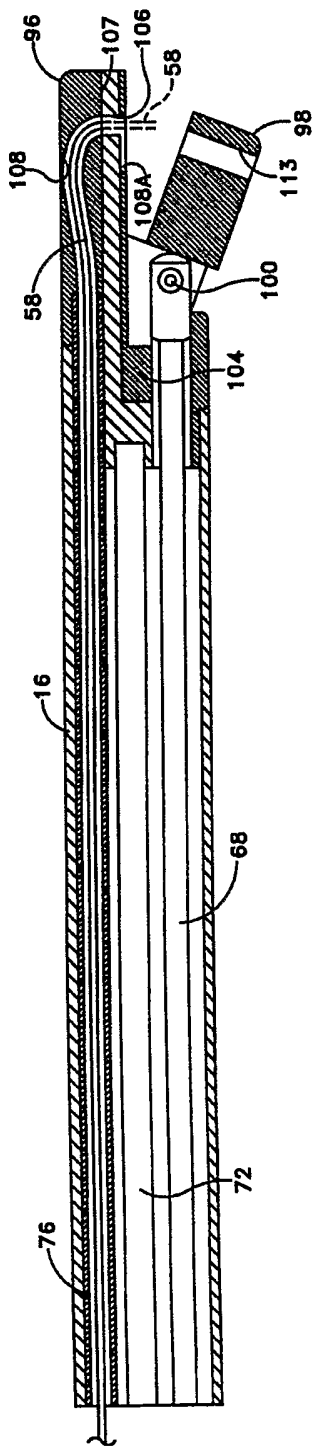

FIG. 14

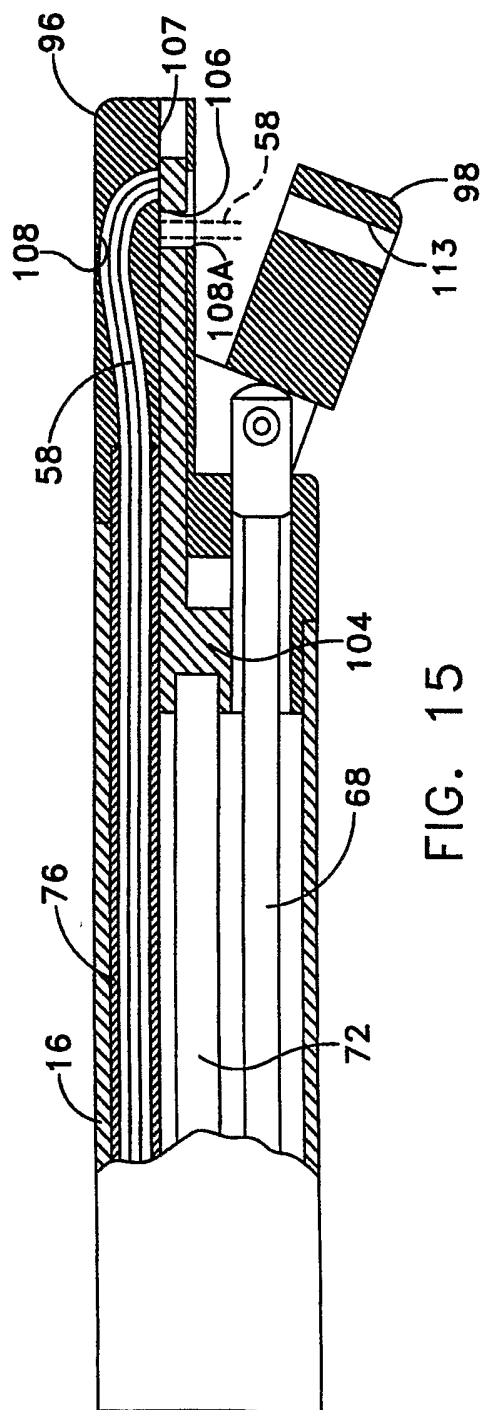

FIG. 15

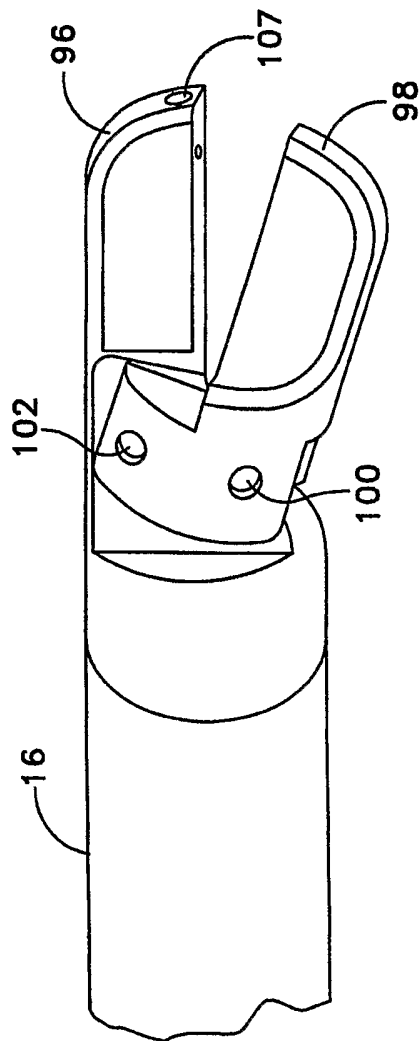

FIG. 16

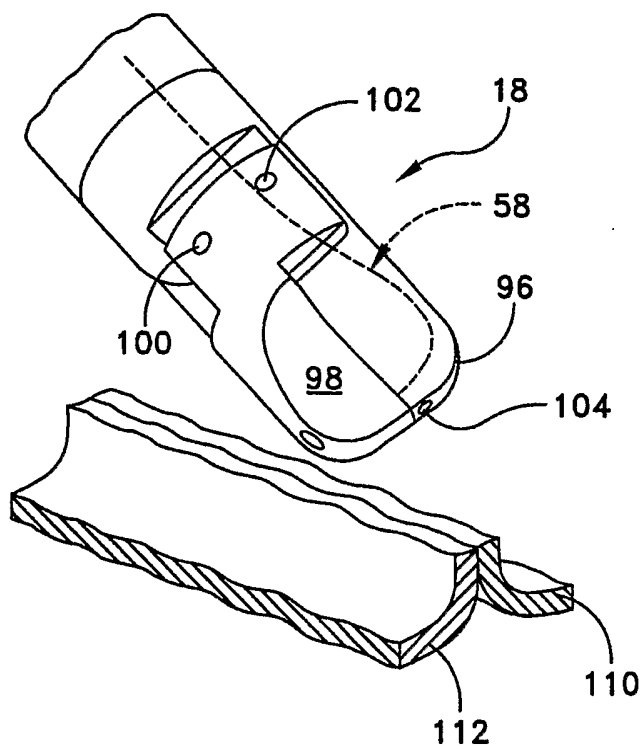

FIG. 17A

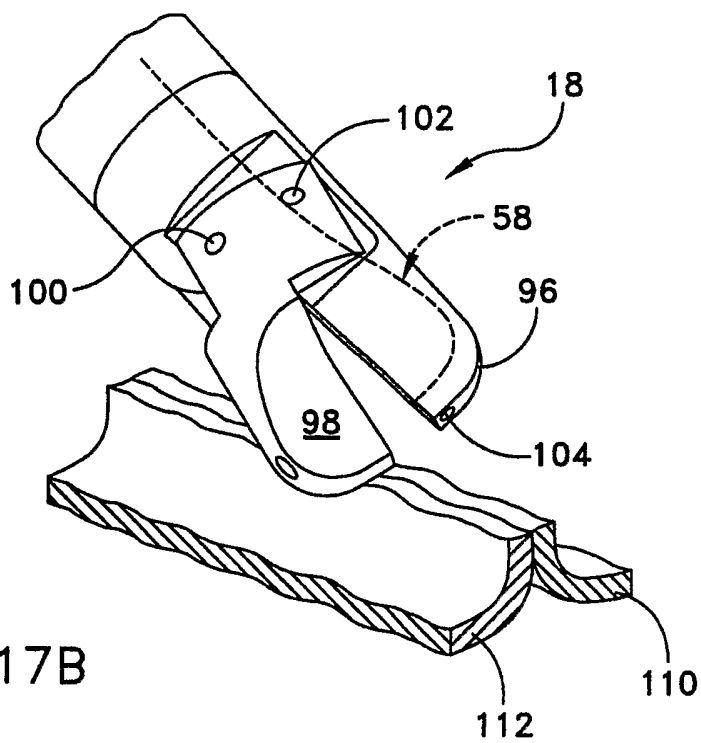

FIG. 17B

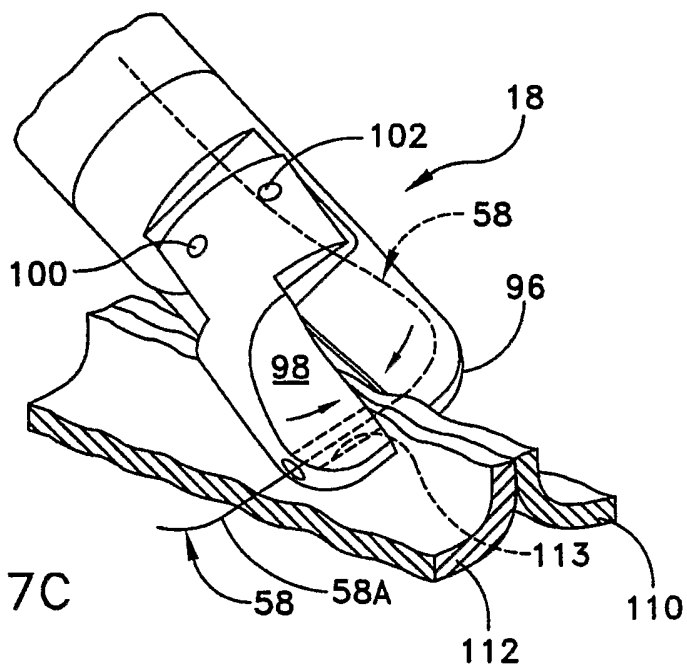

FIG. 17C

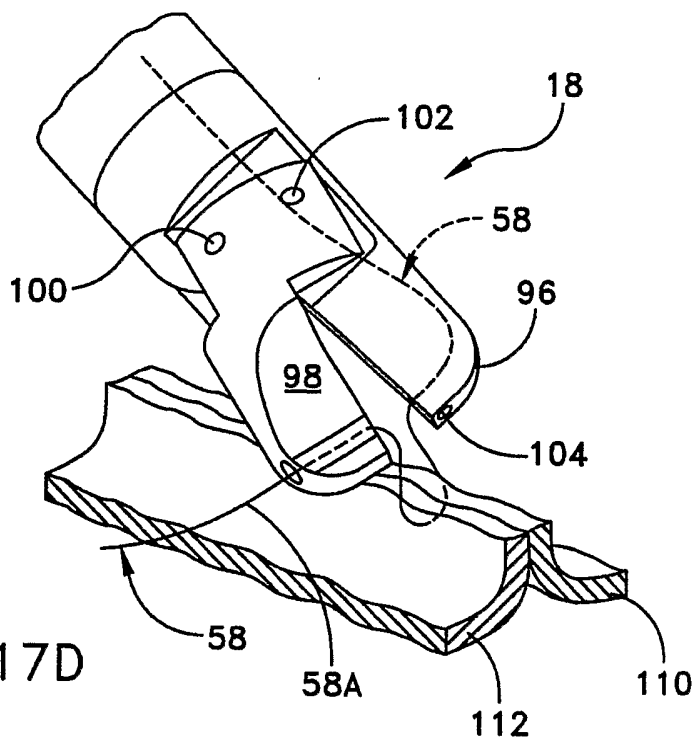

FIG. 17D

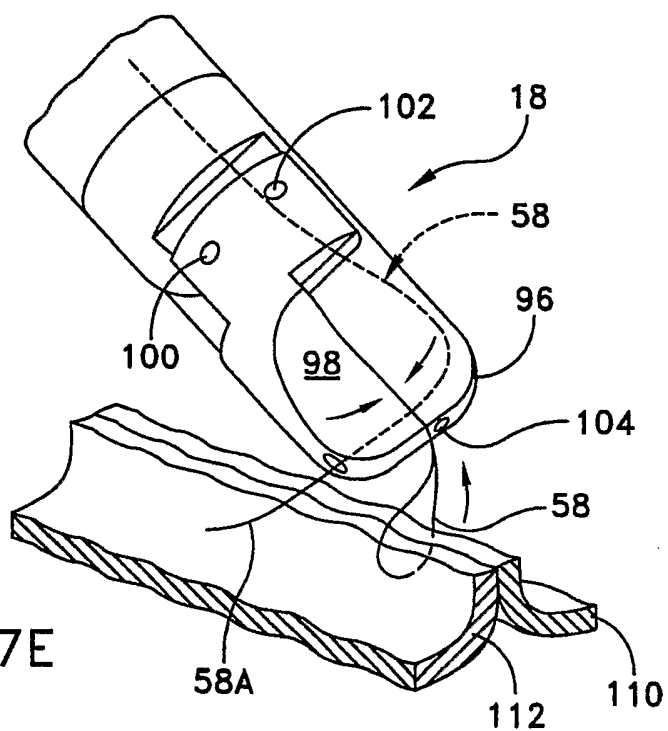

FIG. 17E

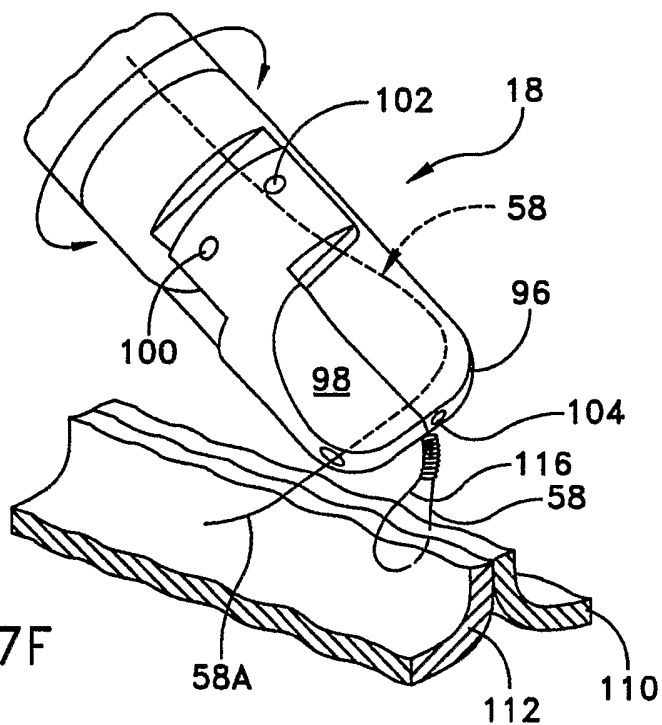

FIG. 17F

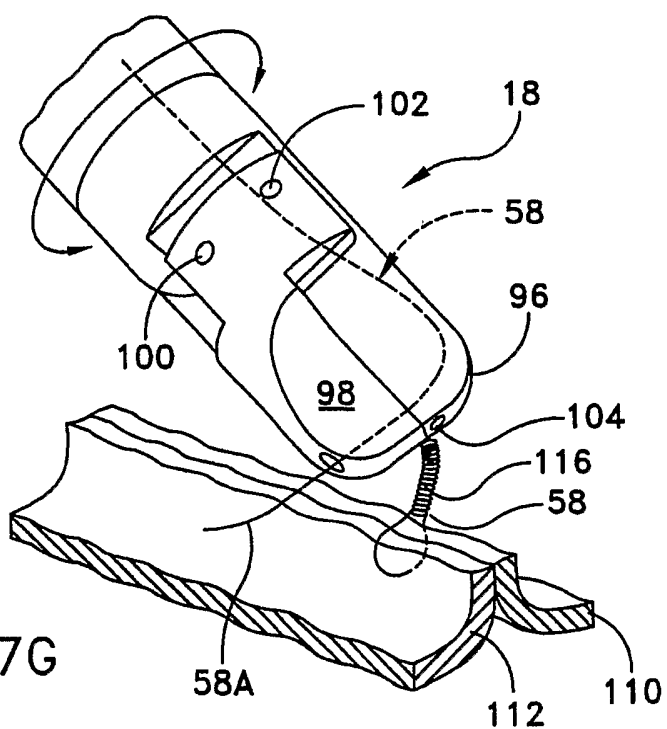

FIG. 17G

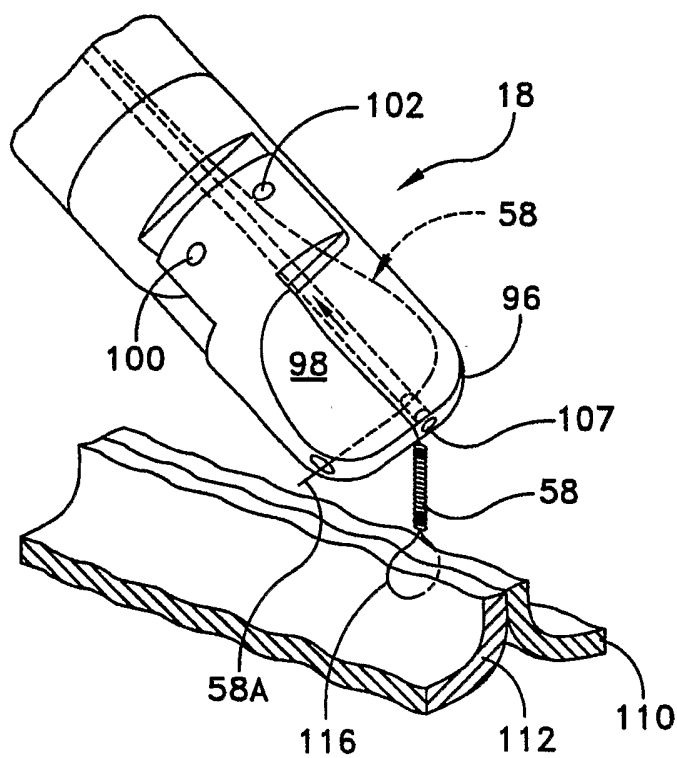
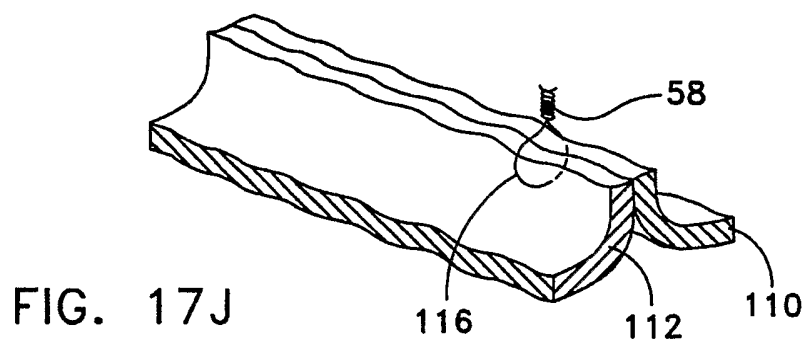
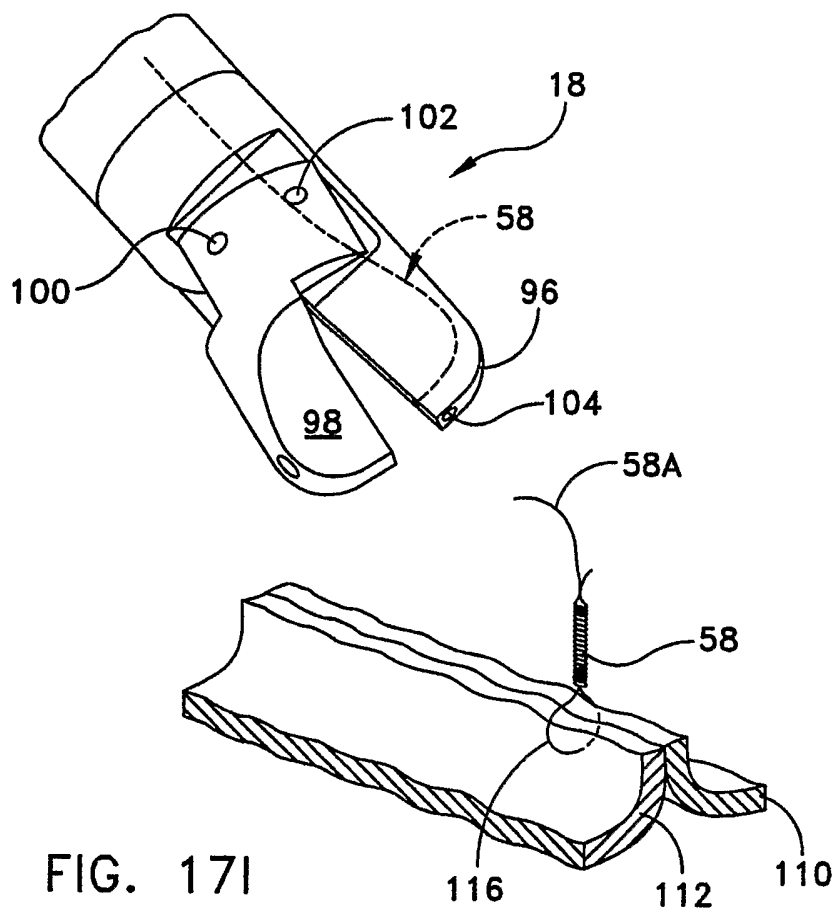

FIG. 17H



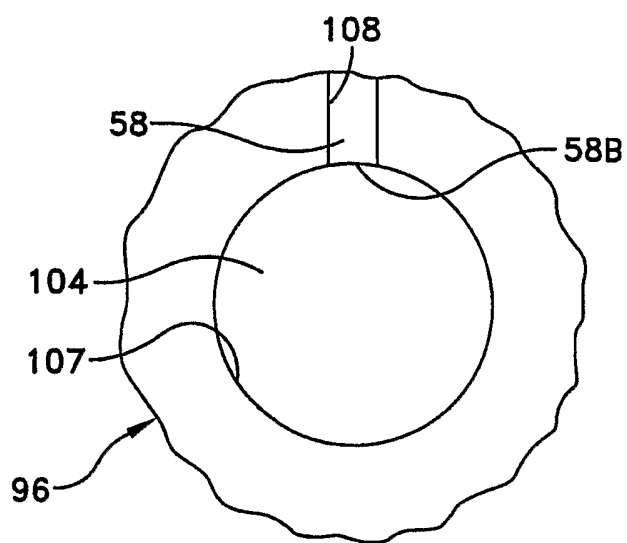

FIG. 18

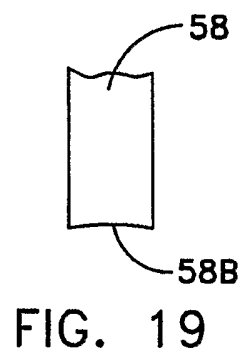

FIG. 19

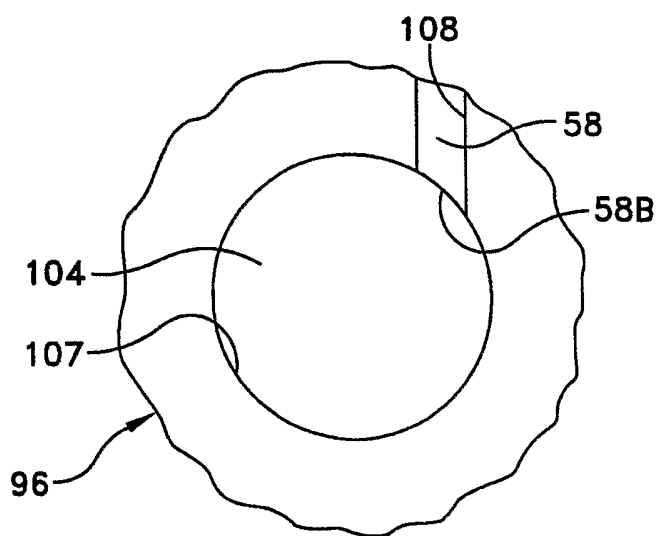

FIG. 20

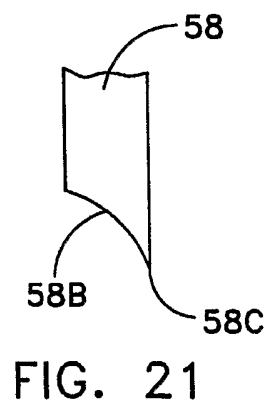

FIG. 21

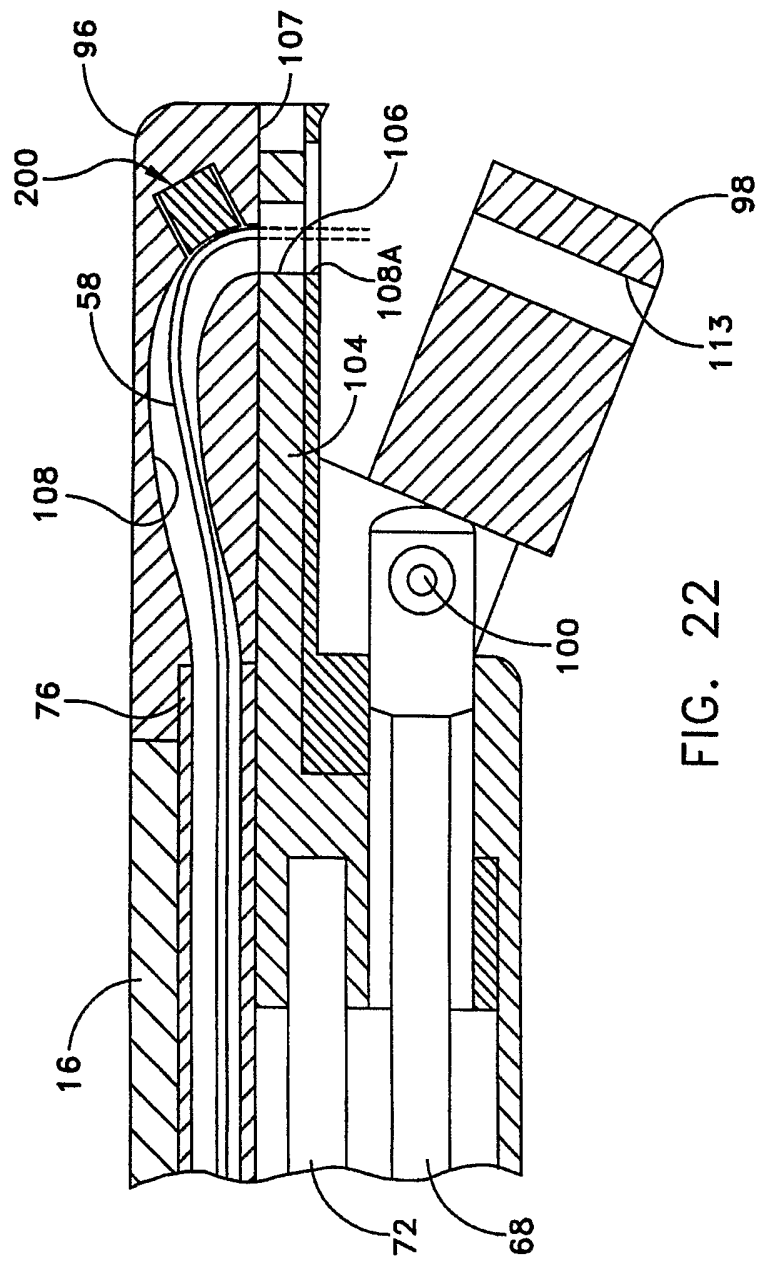

FIG. 22

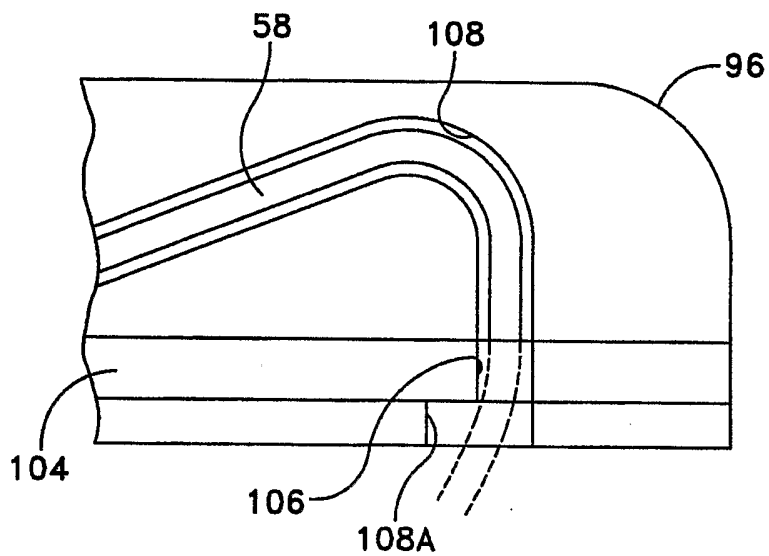

FIG. 23A

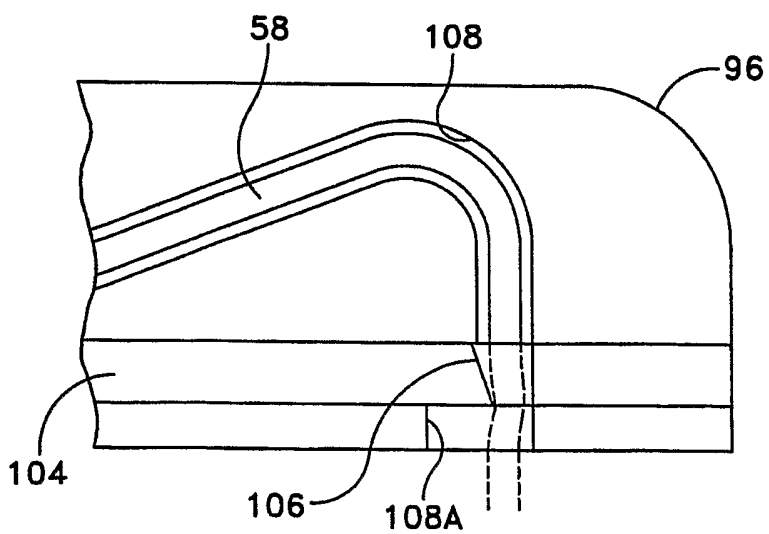

FIG. 23B

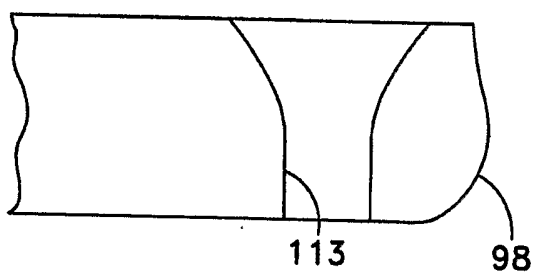

FIG. 23C

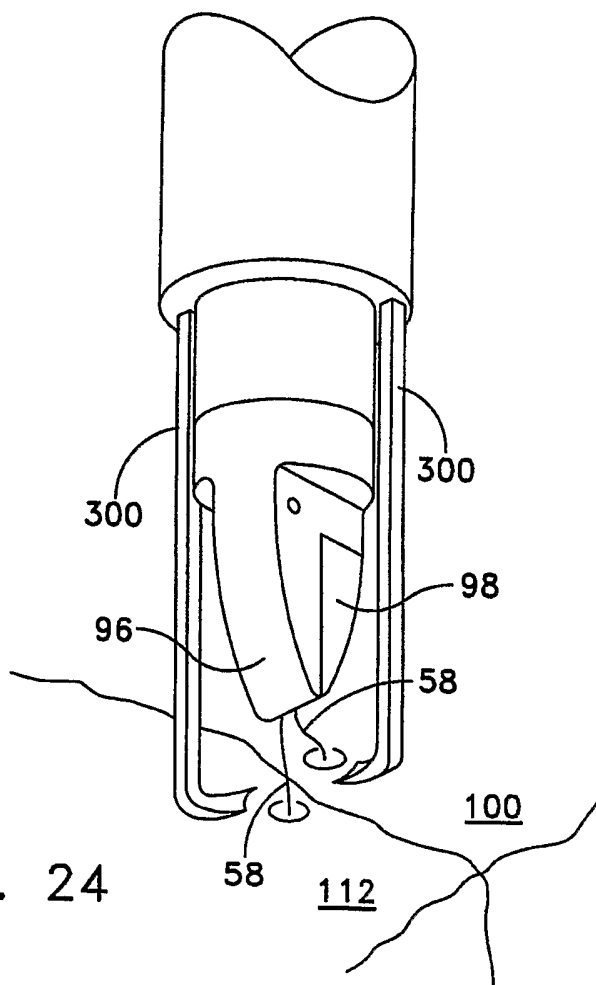

FIG. 24

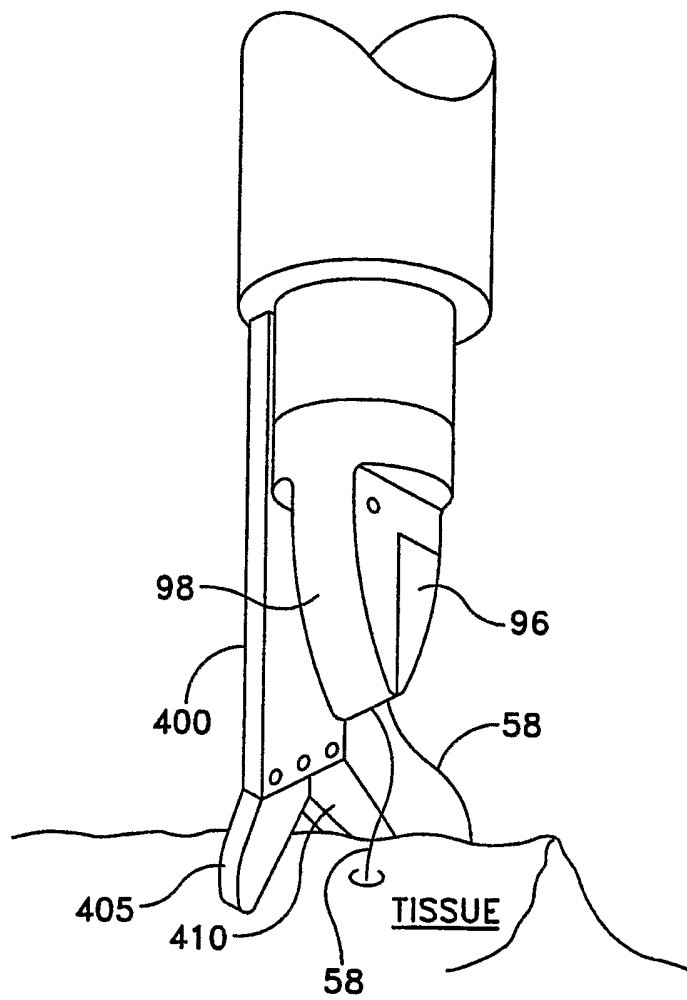

FIG. 25

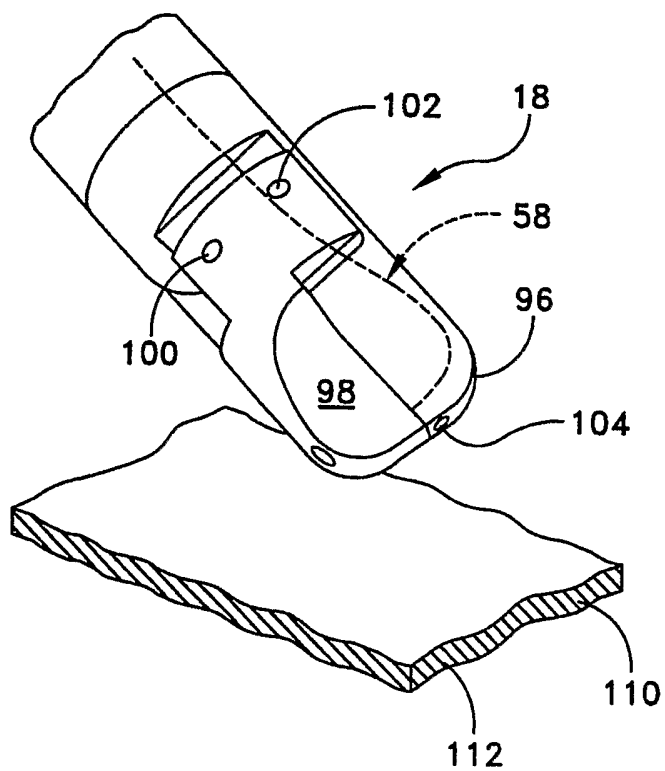

FIG. 26

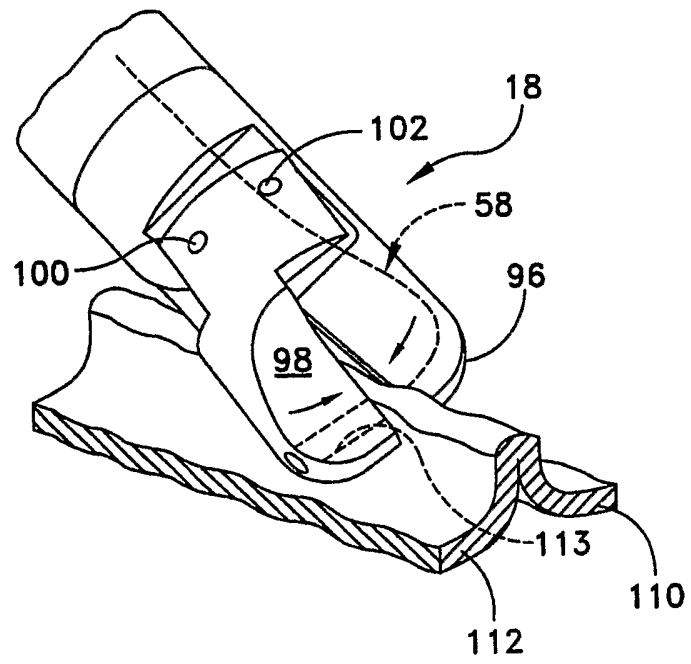

FIG. 27

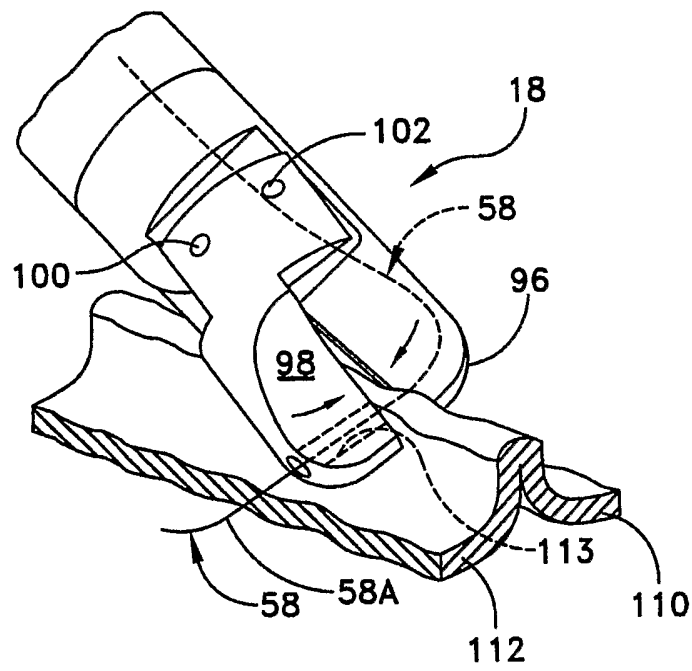

FIG. 28

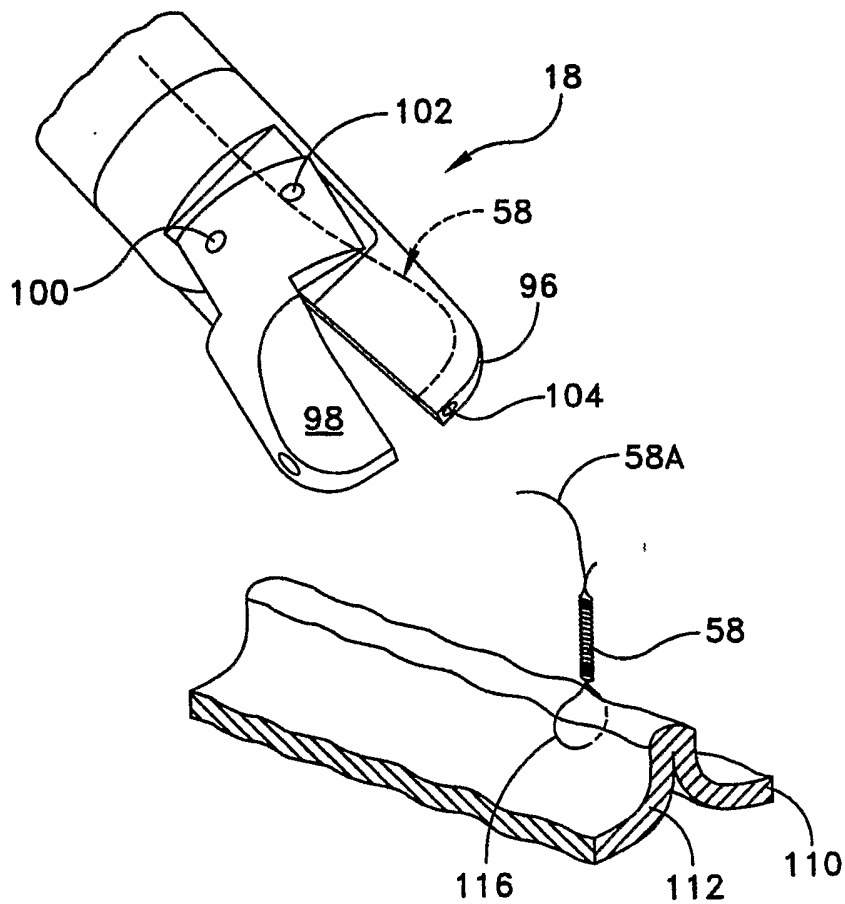

FIG. 29

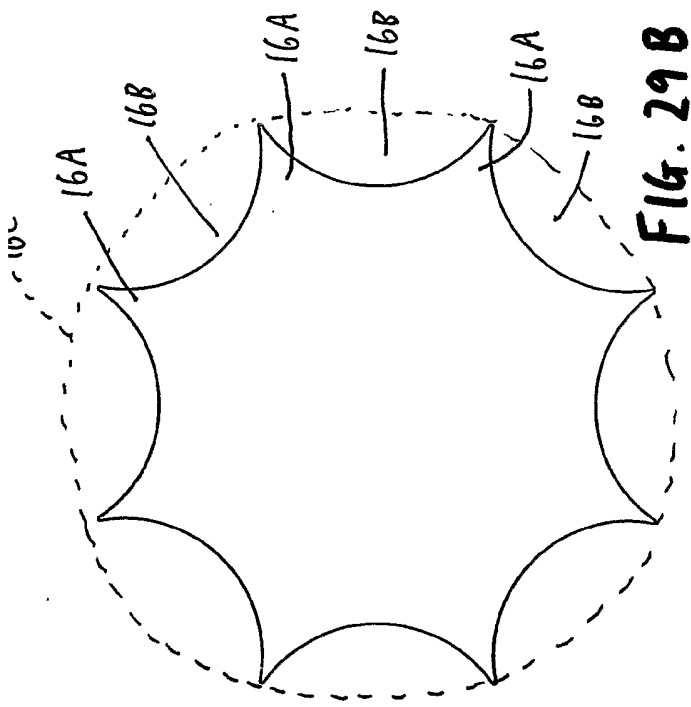

FIG. 29B

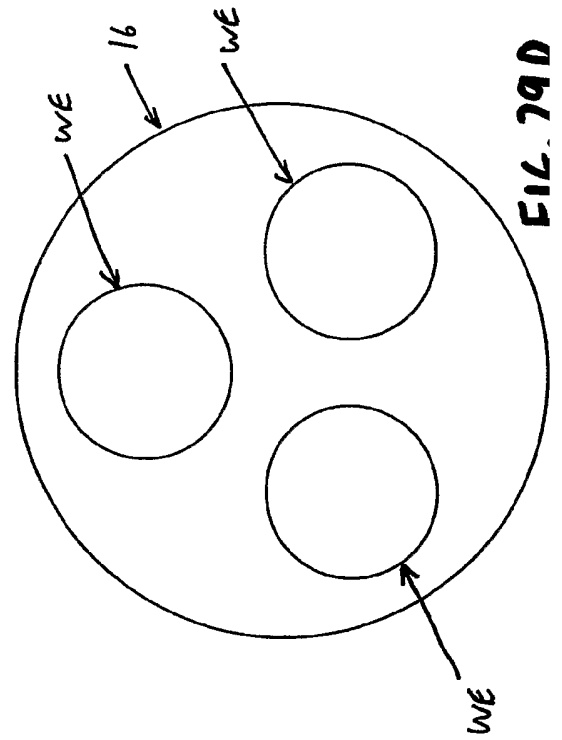

FIG. 29D

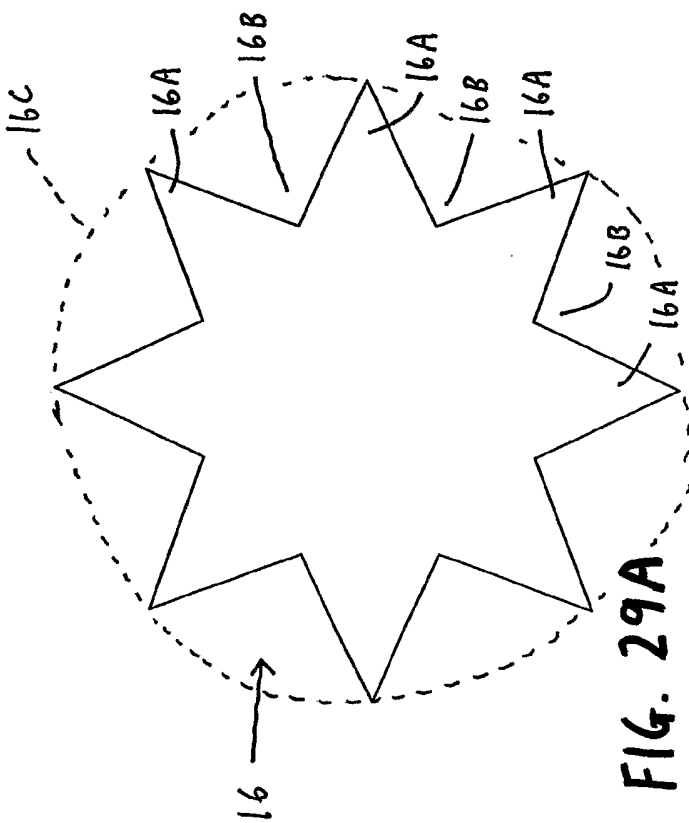

FIG. 29A

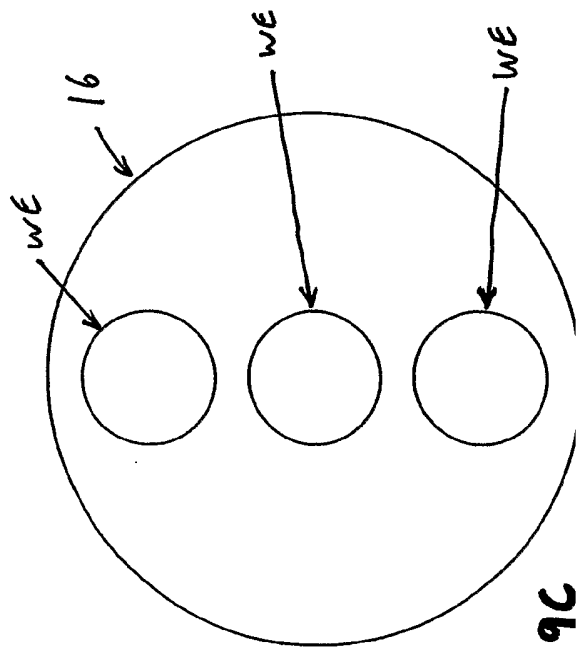

FIG. 29C

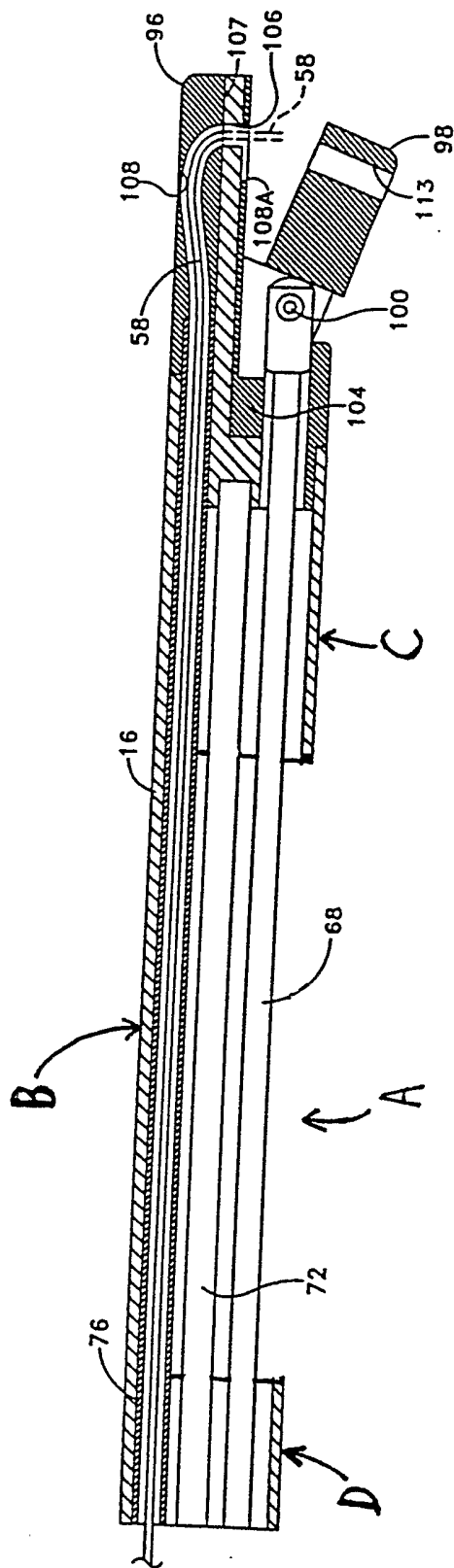
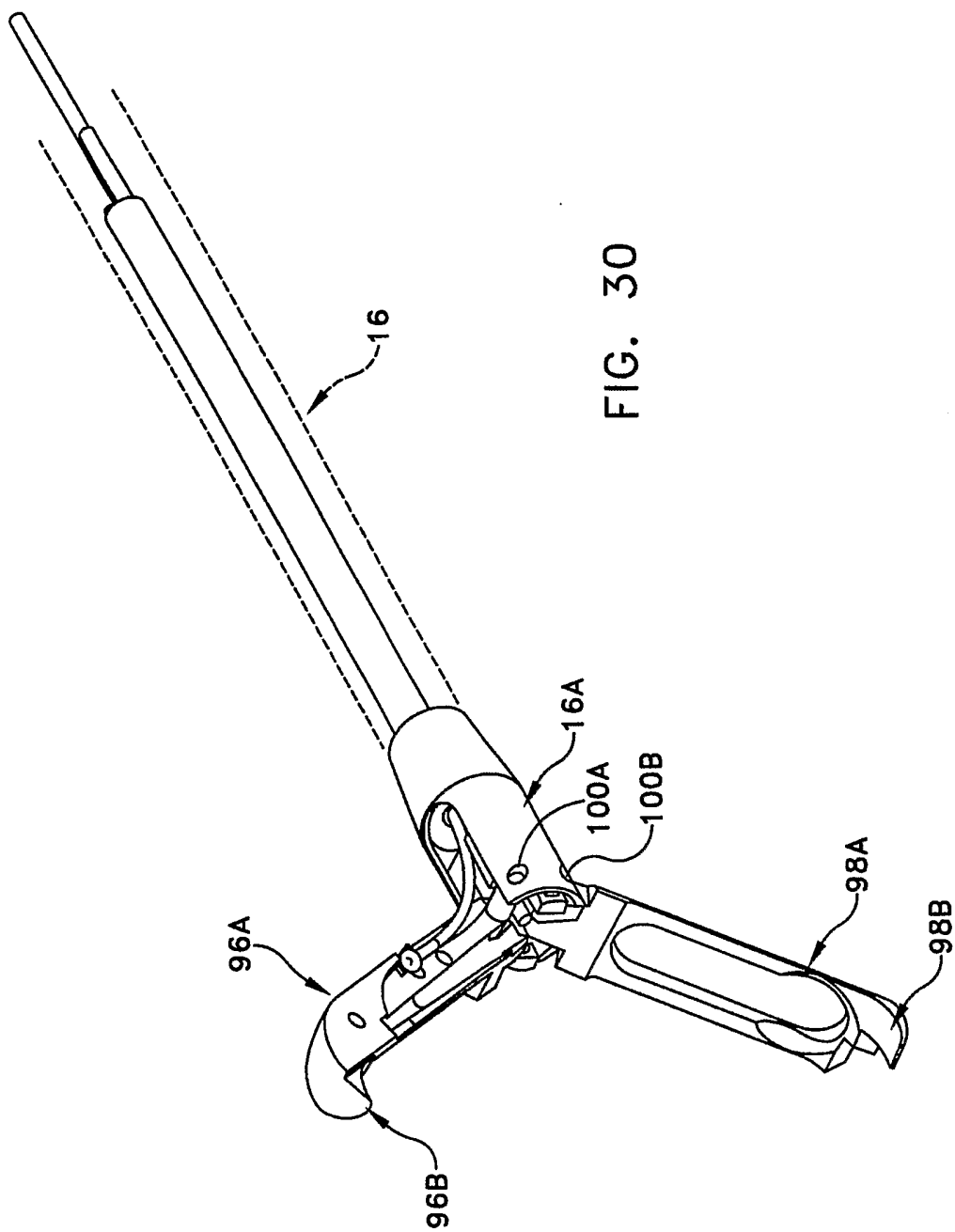

FIG. 29E



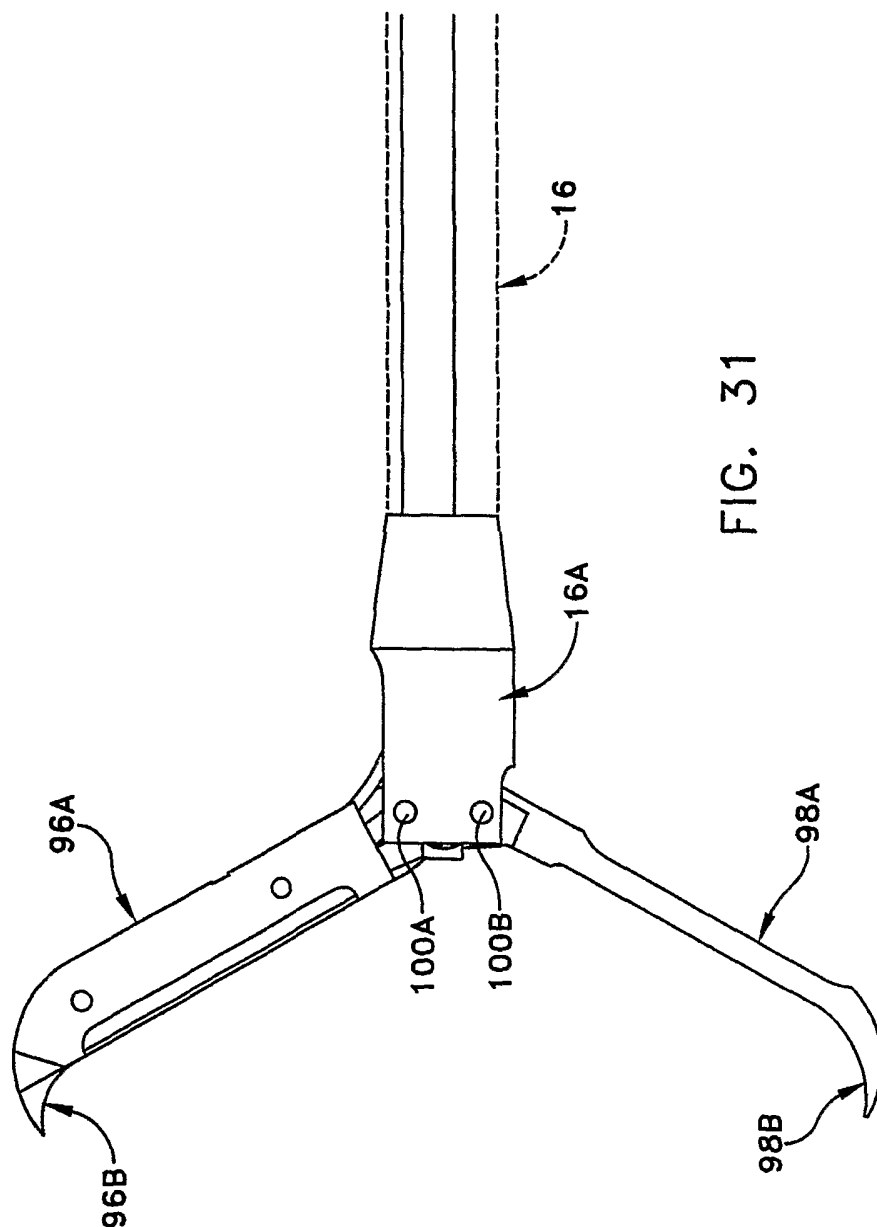

FIG. 31

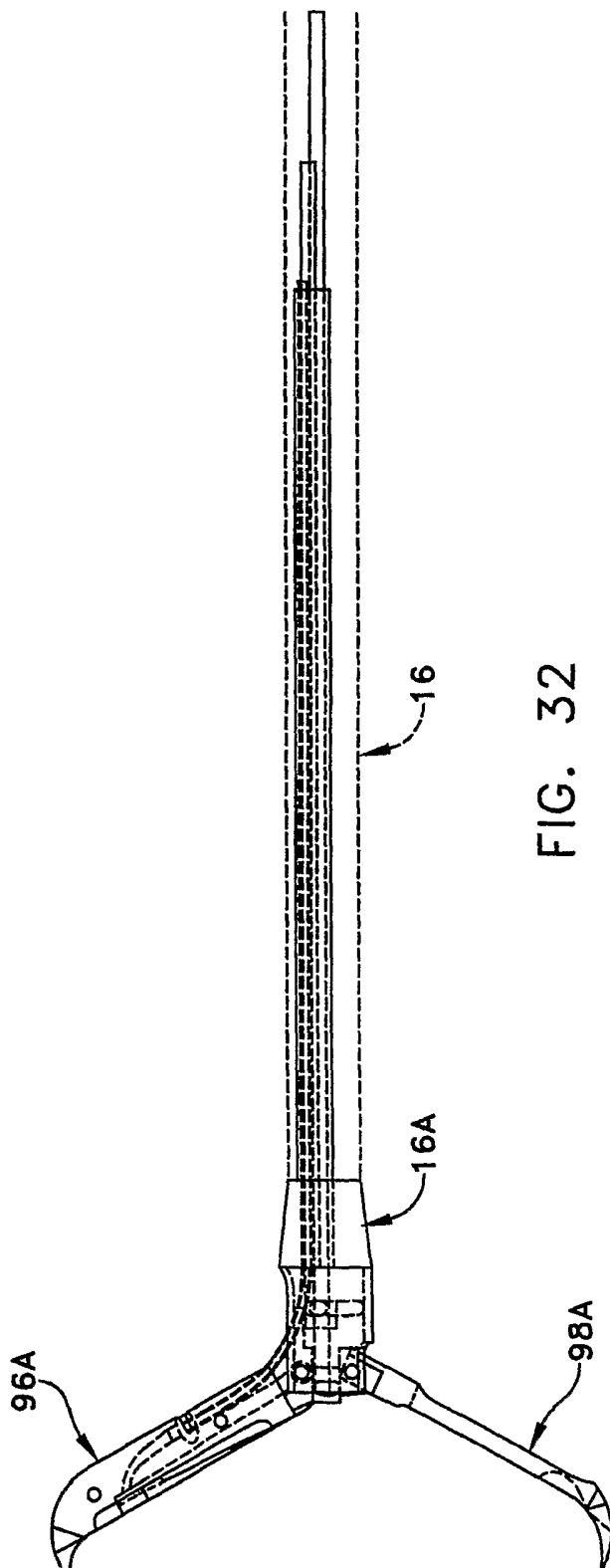
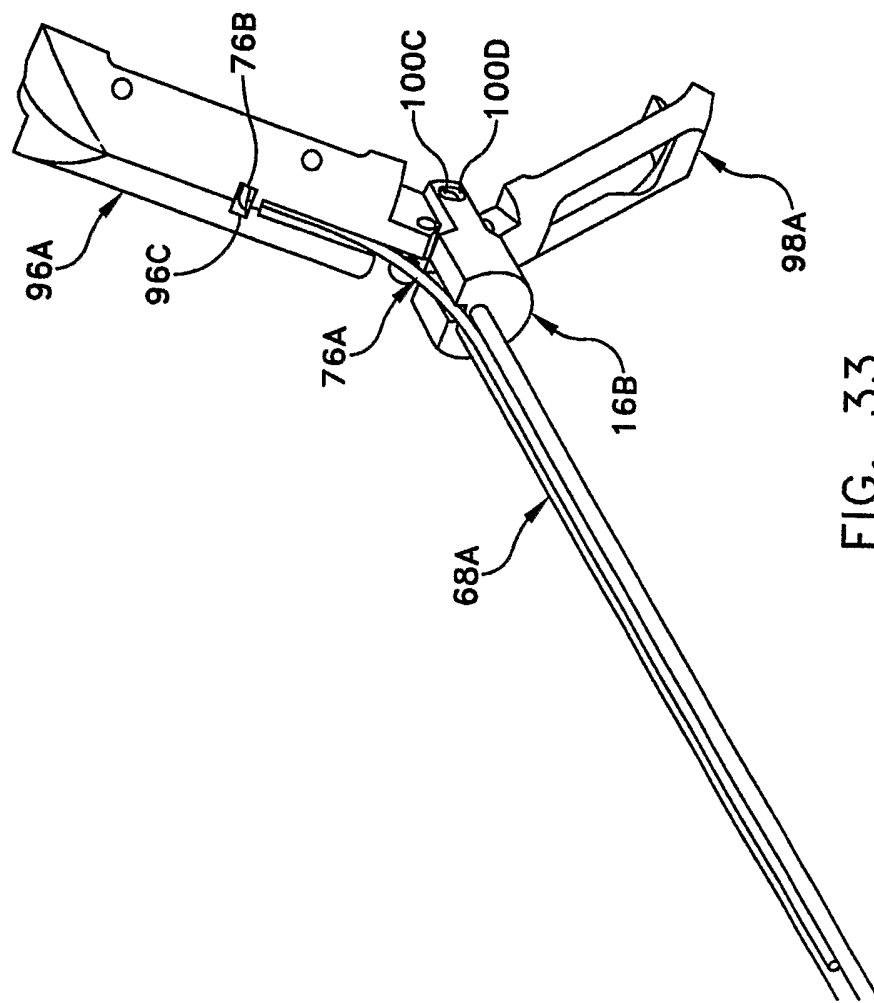

FIG. 32



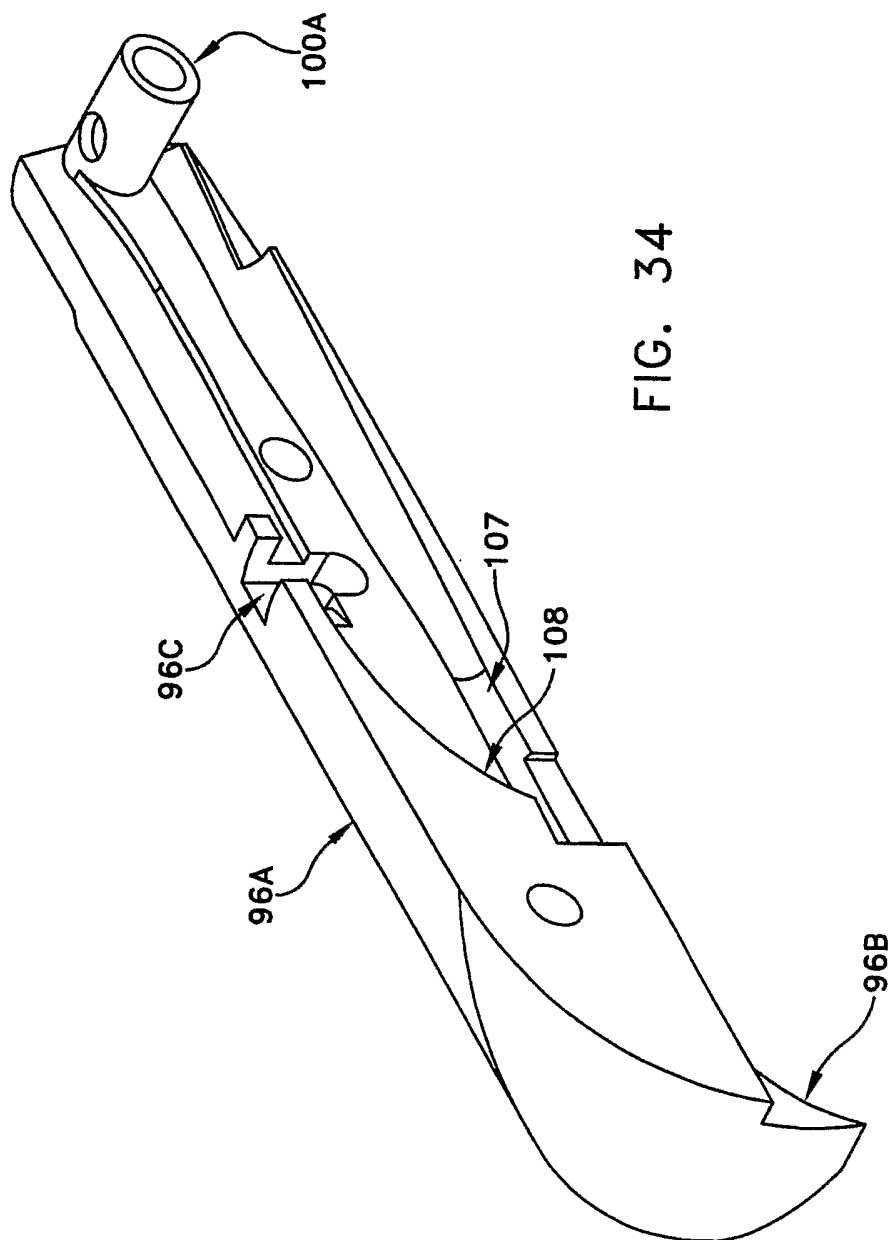

FIG. 34

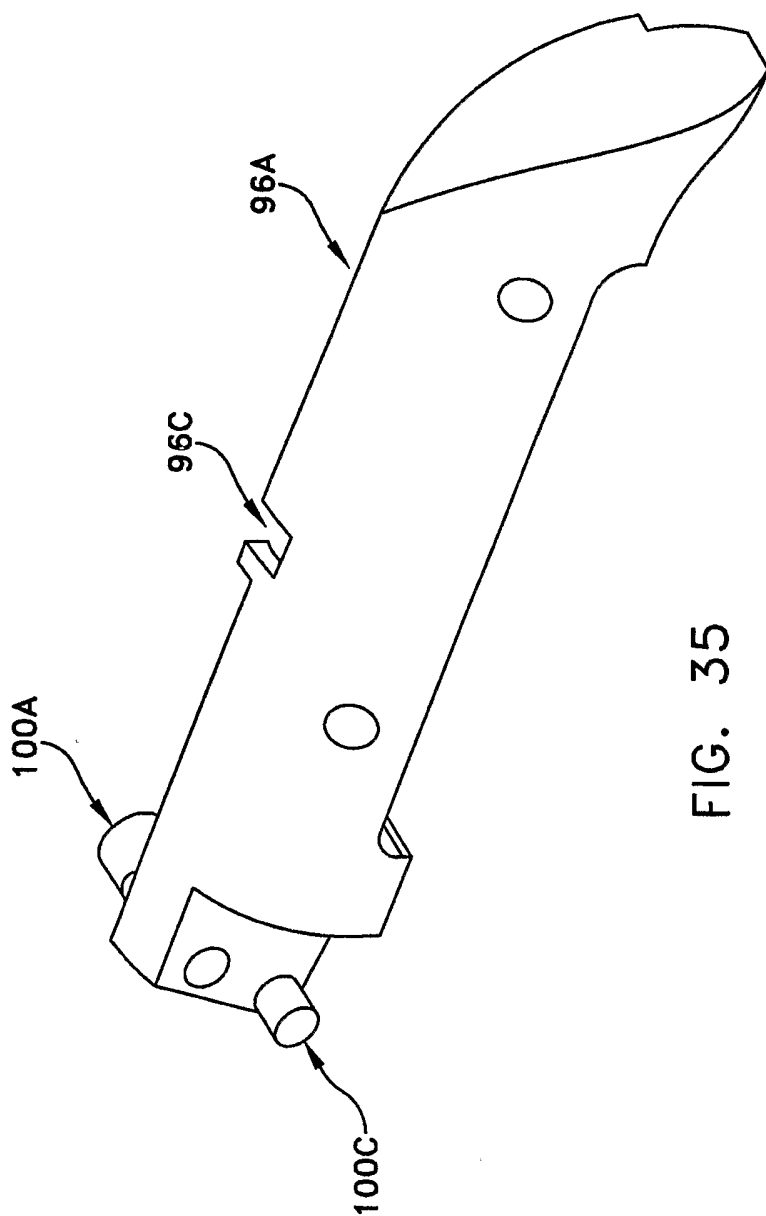

FIG. 35

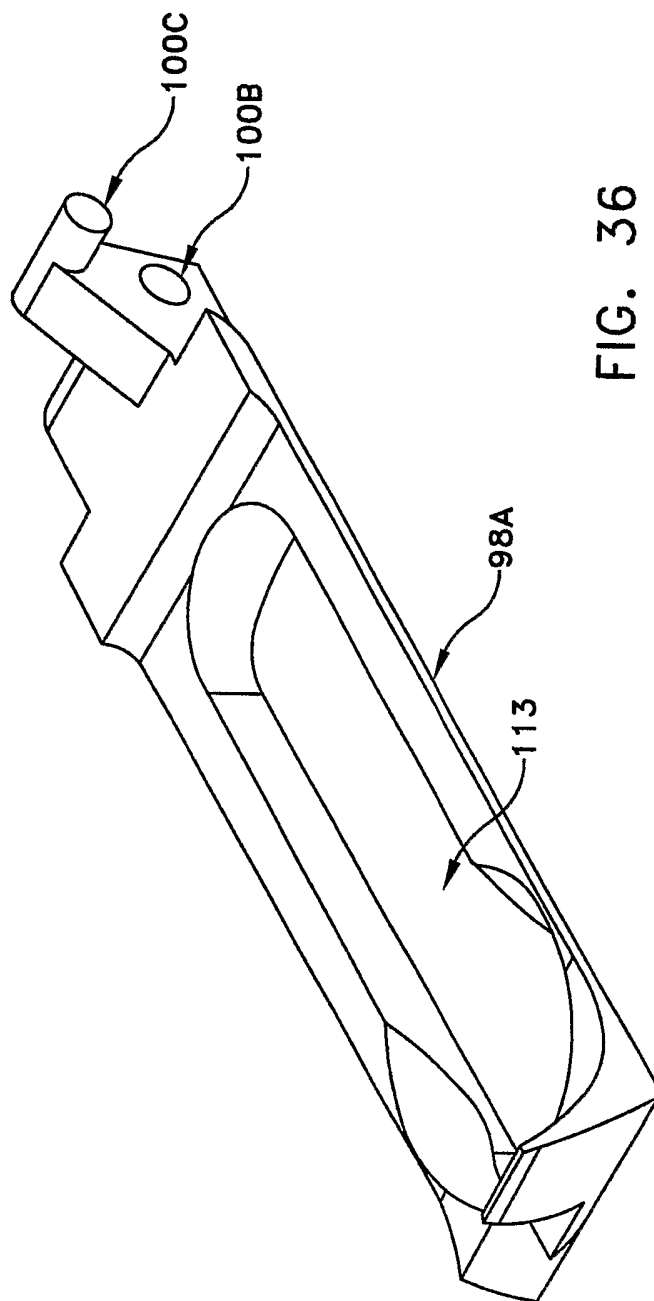

FIG. 36

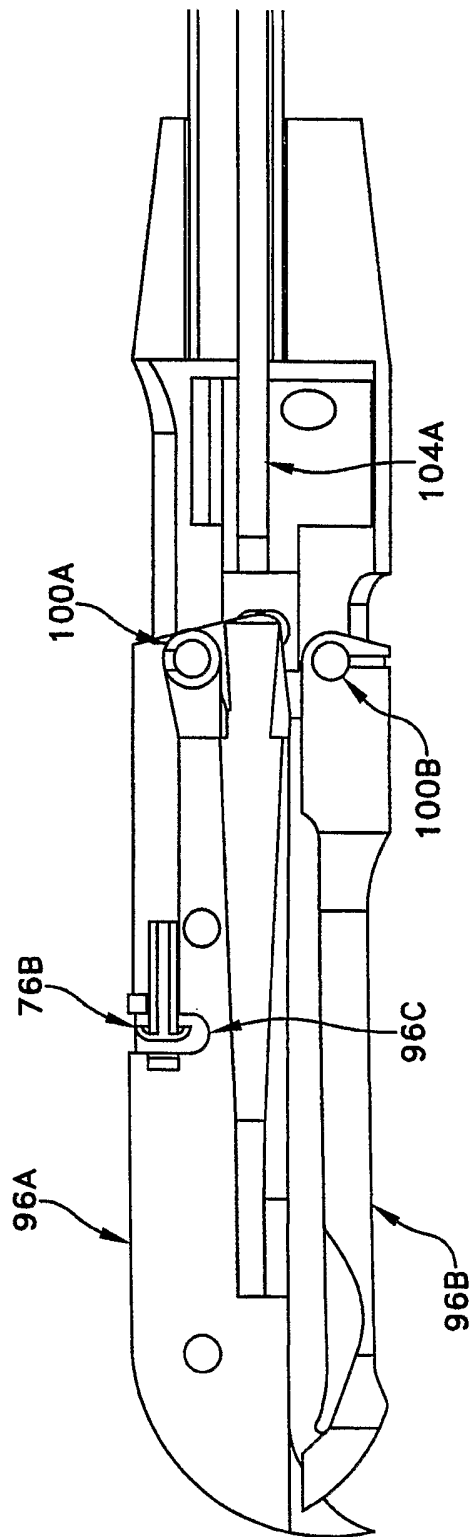

FIG. 37

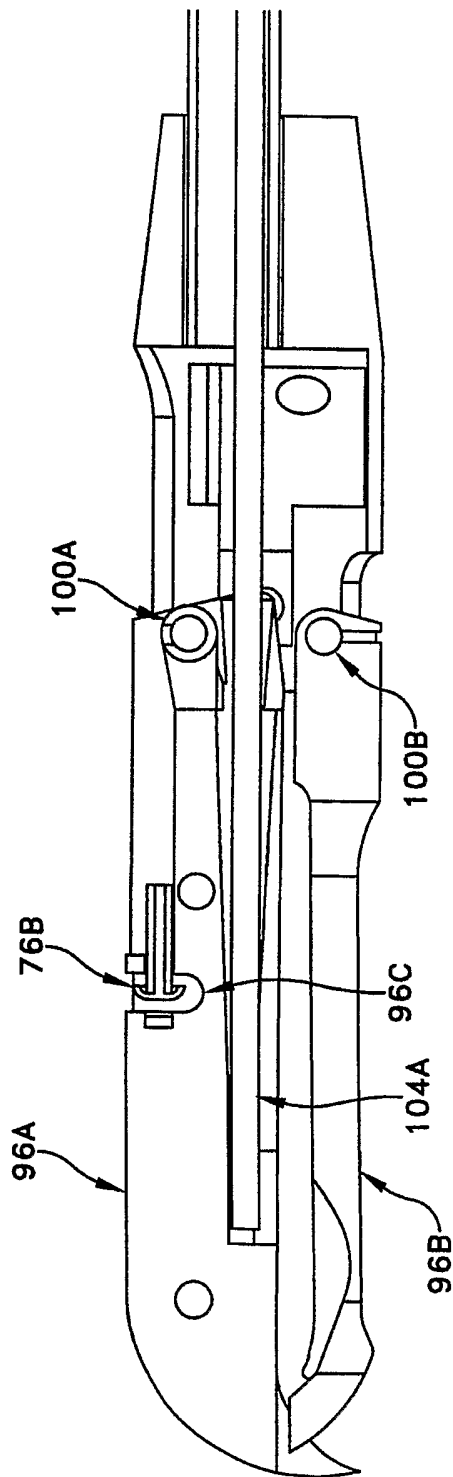

FIG. 38

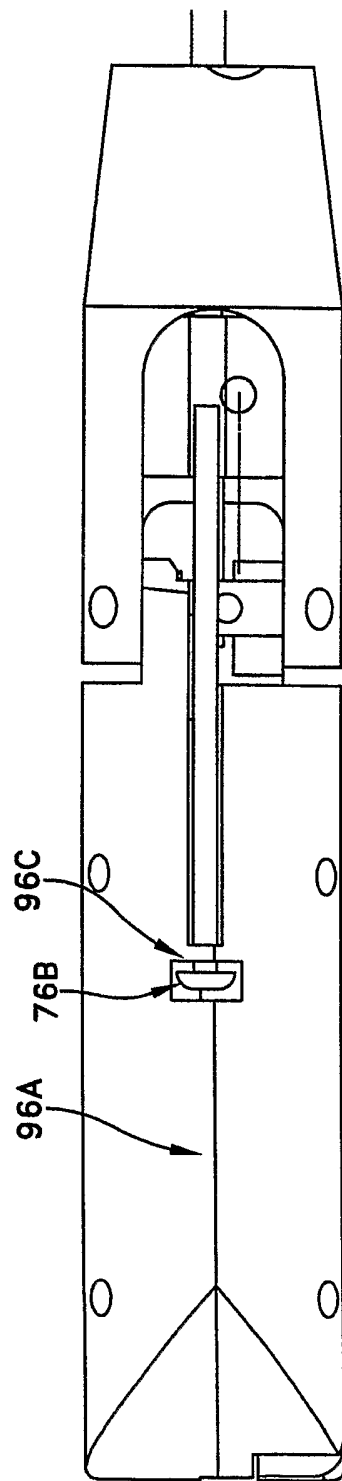

FIG. 39

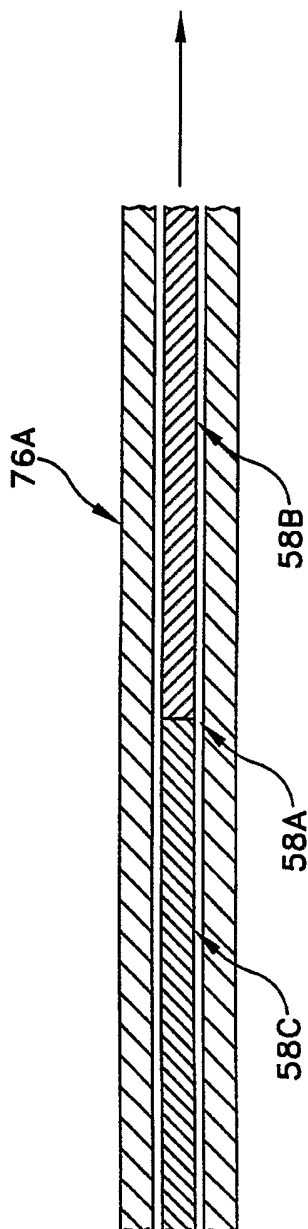
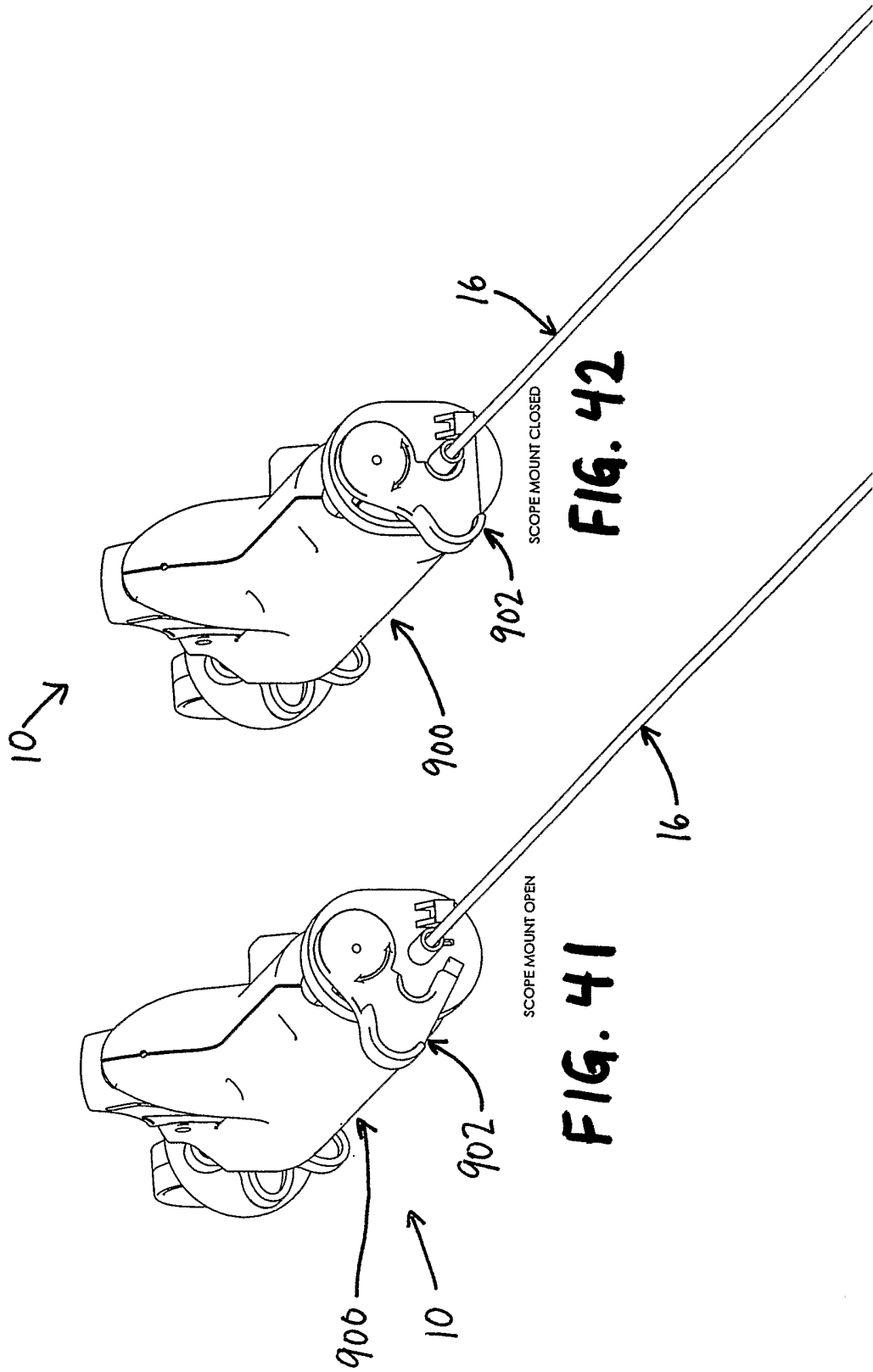
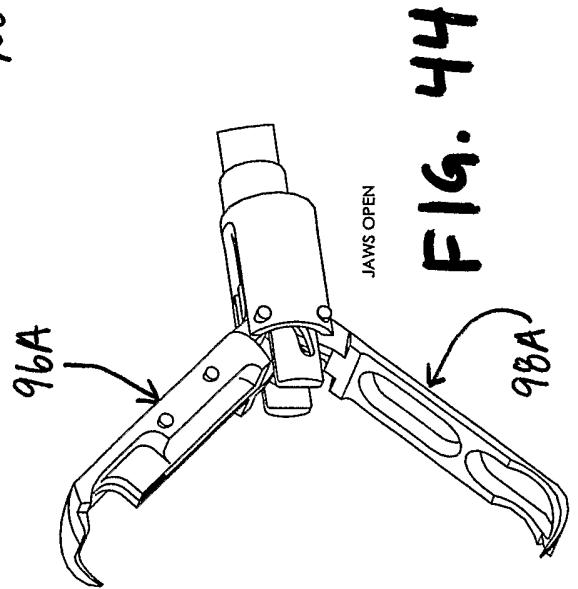
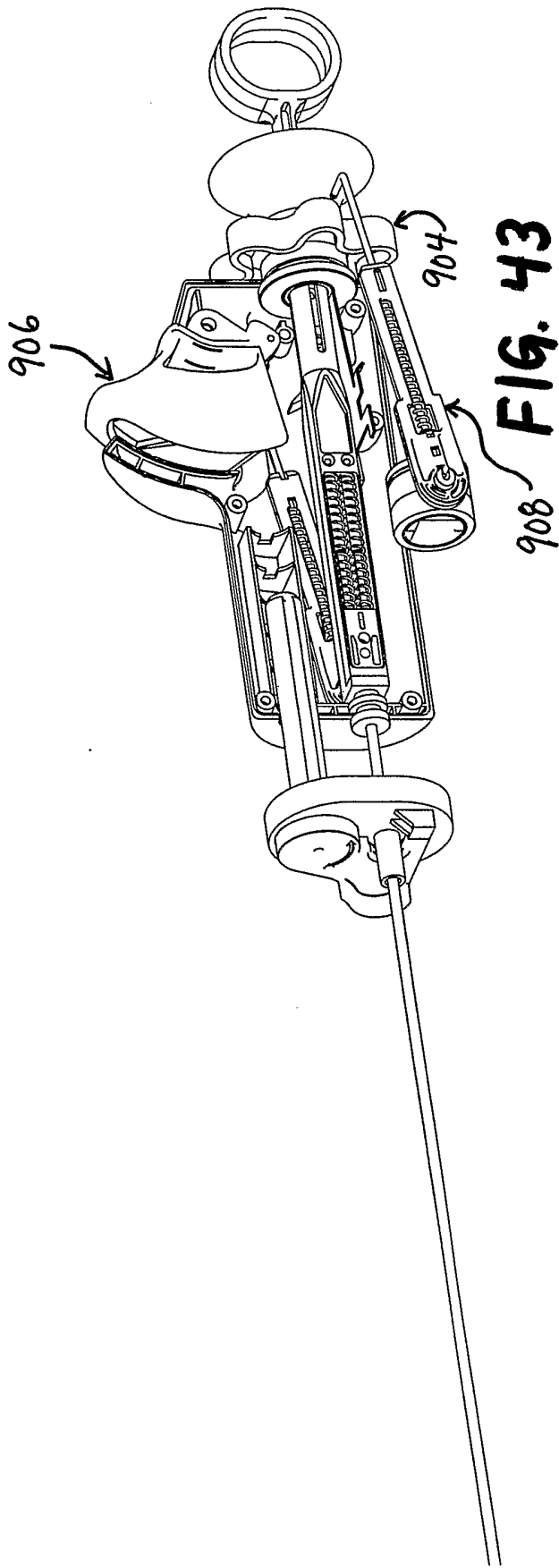

FIG. 40





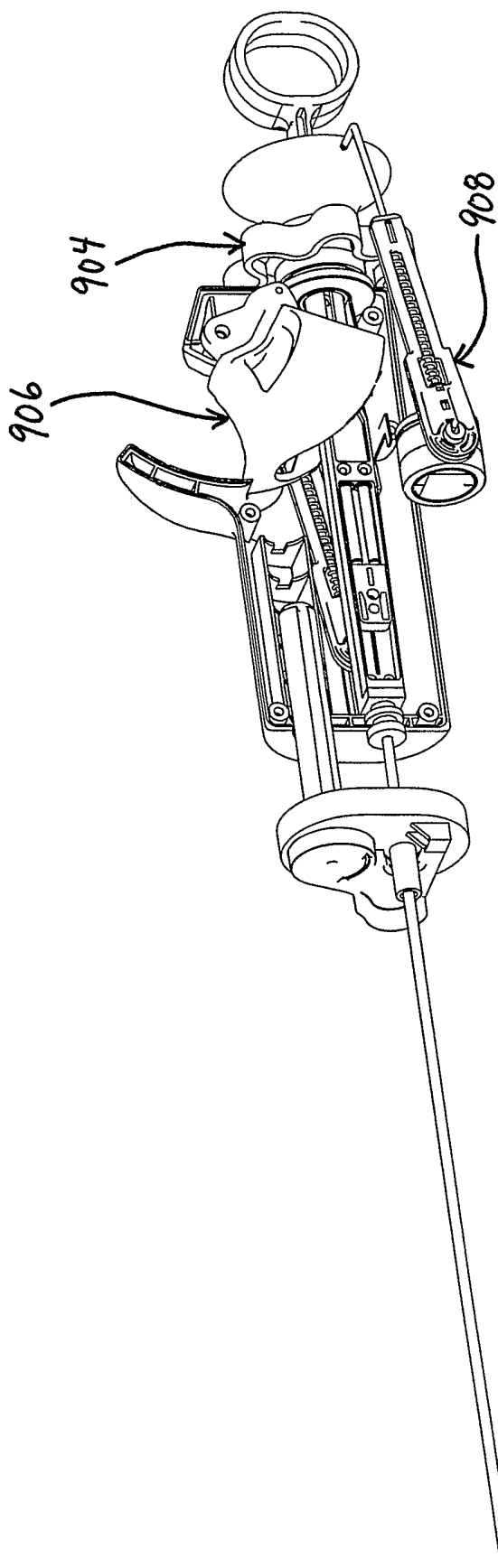

FIG. 45

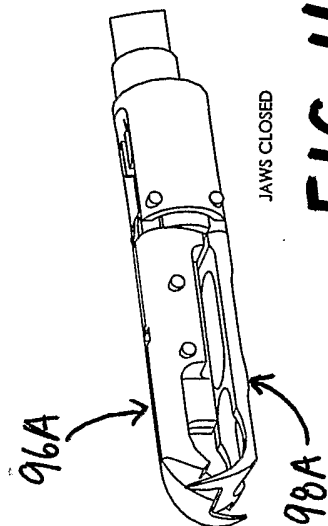

FIG. 46

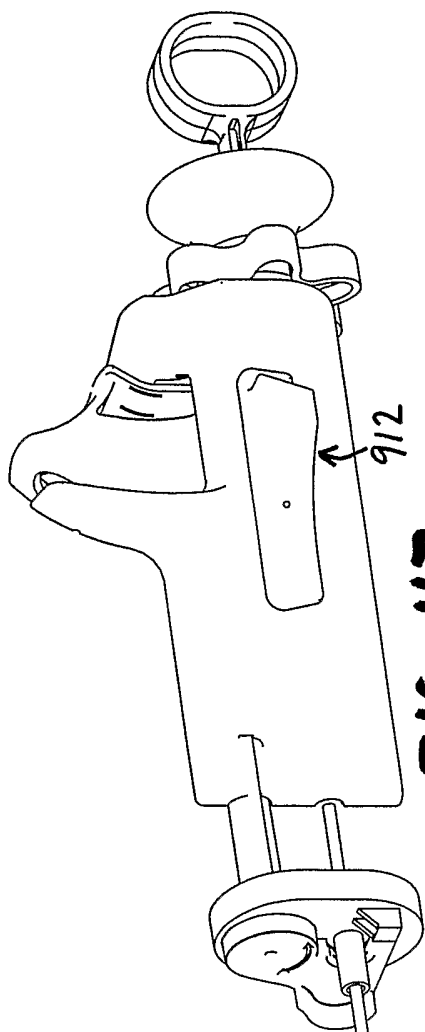

FIG. 47

WIRE DRIVE RETRACTED

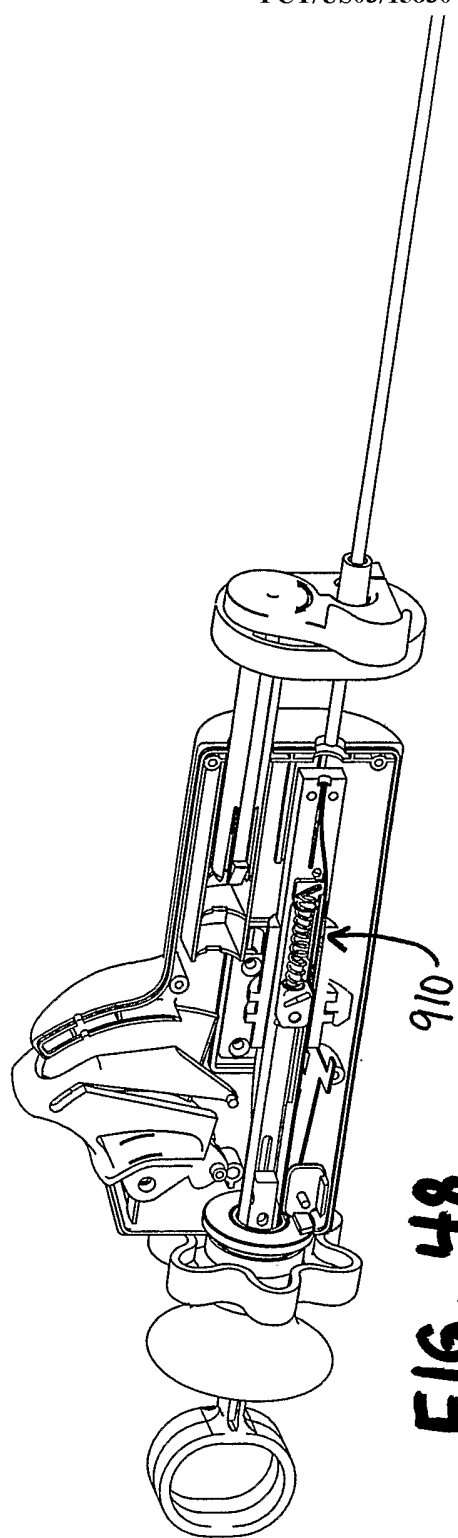
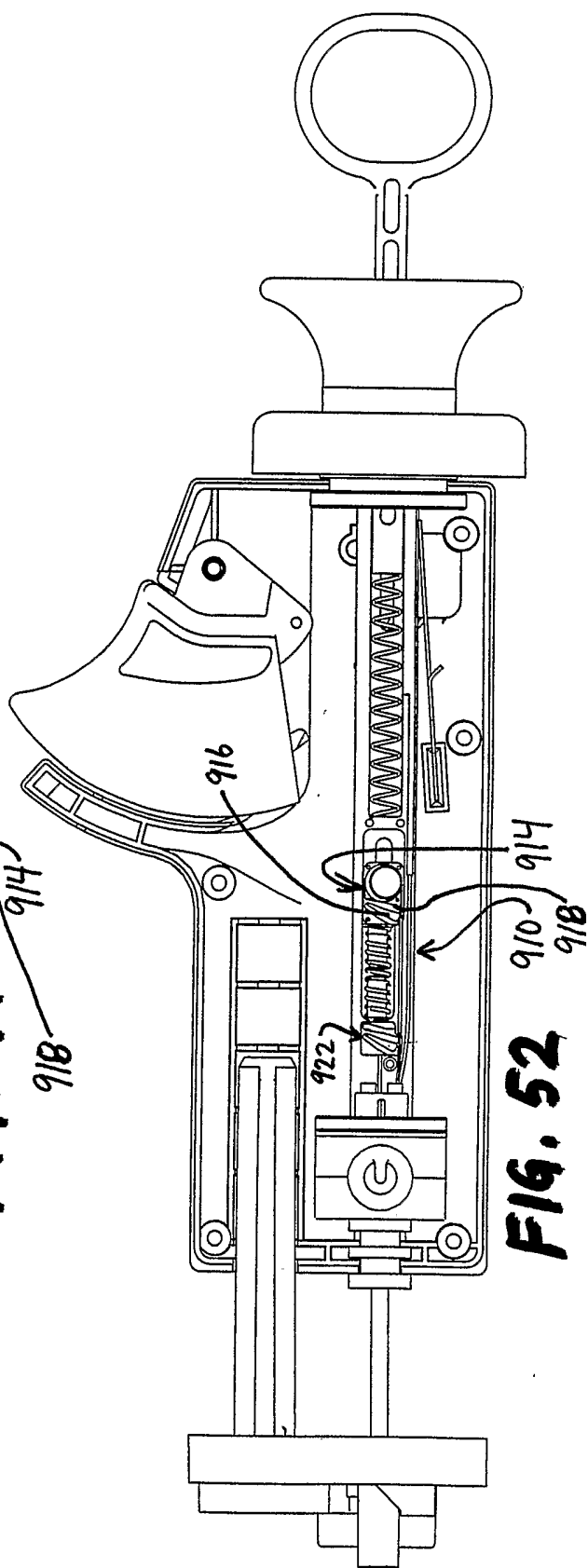
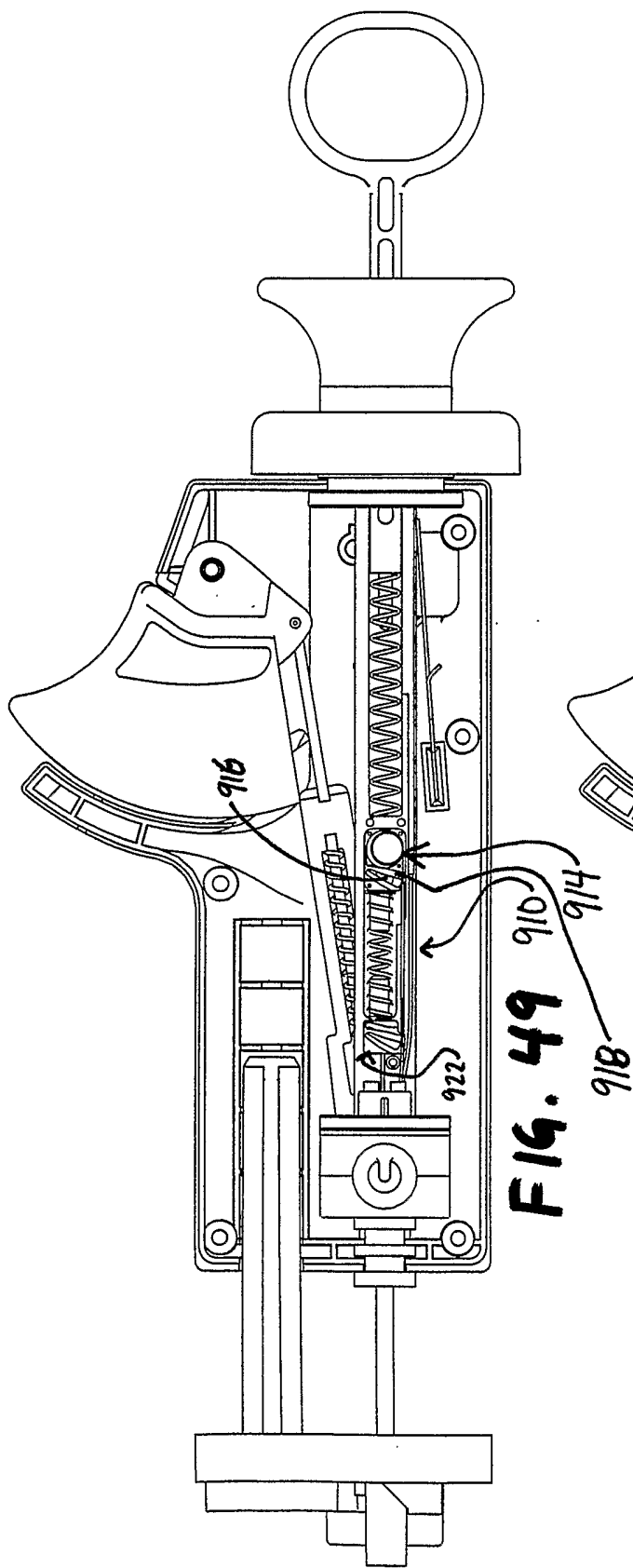

FIG. 48



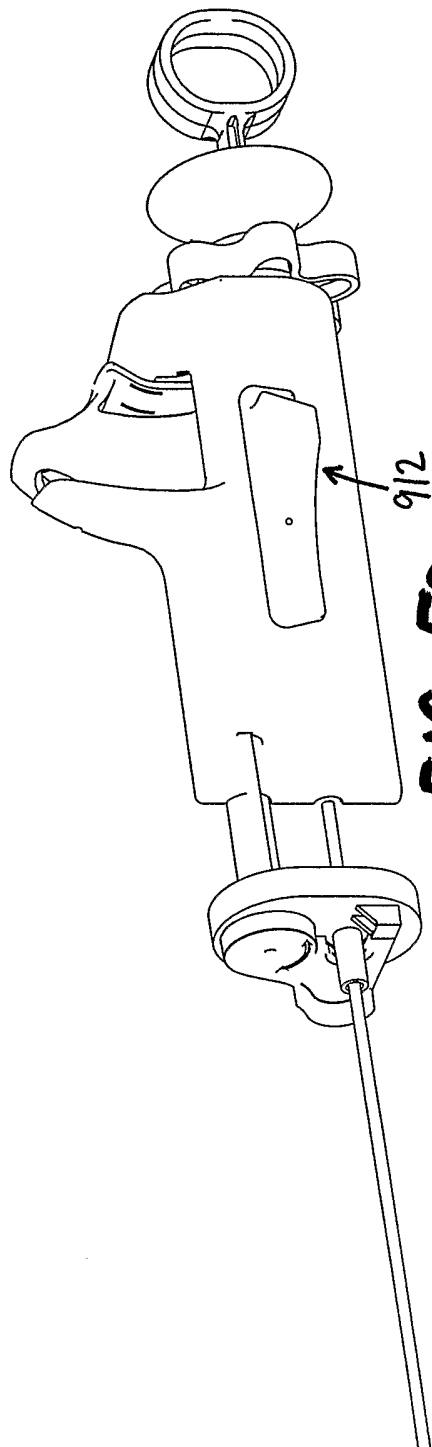

FIG. 50

WIRE DRIVE ADVANCED

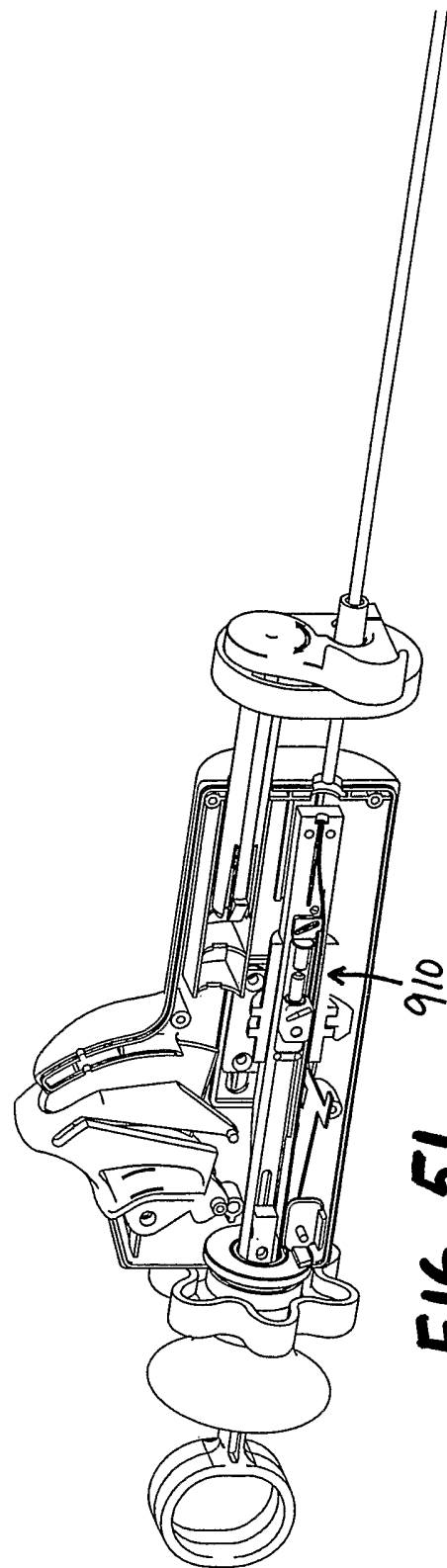

FIG. 51

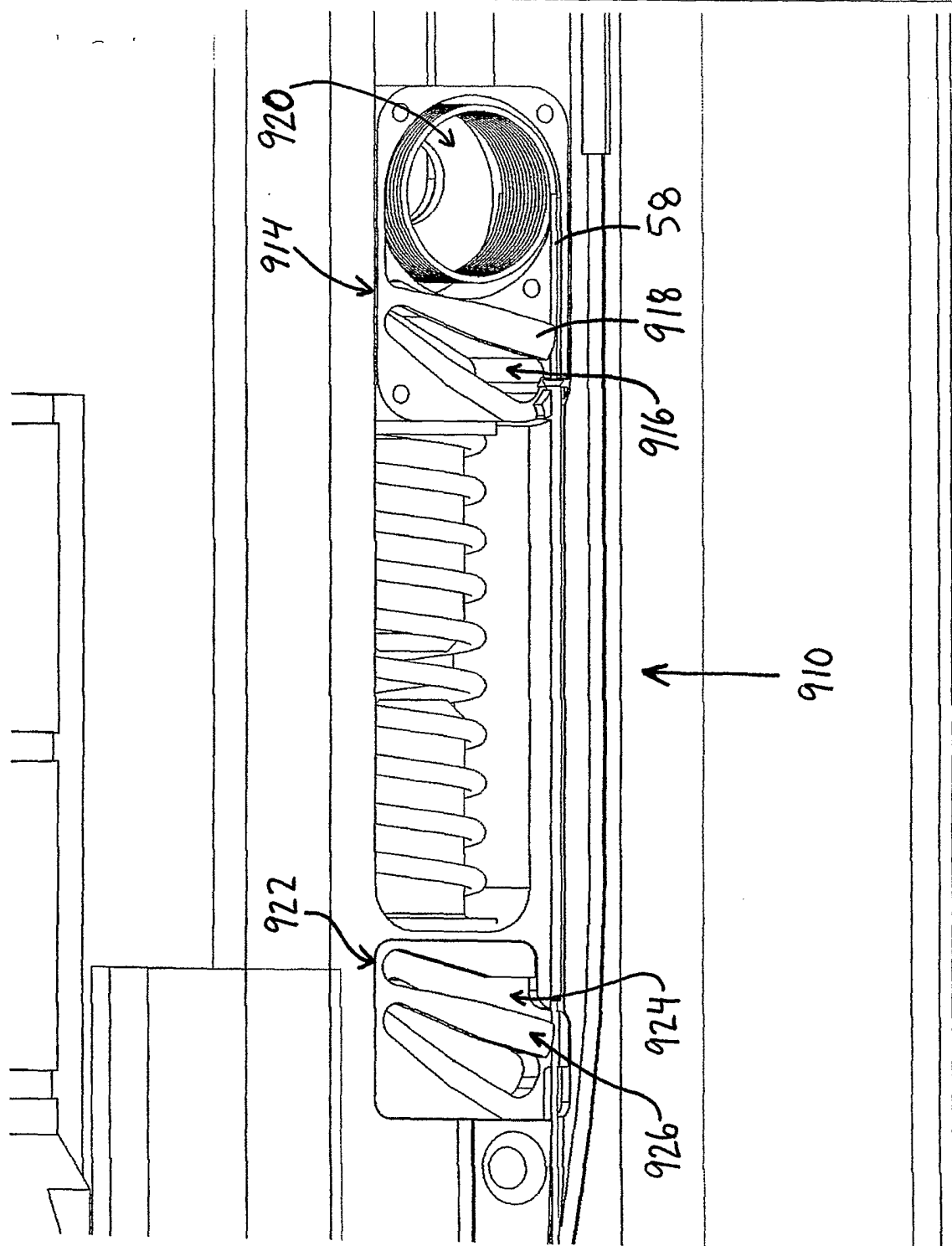

FIG. 53

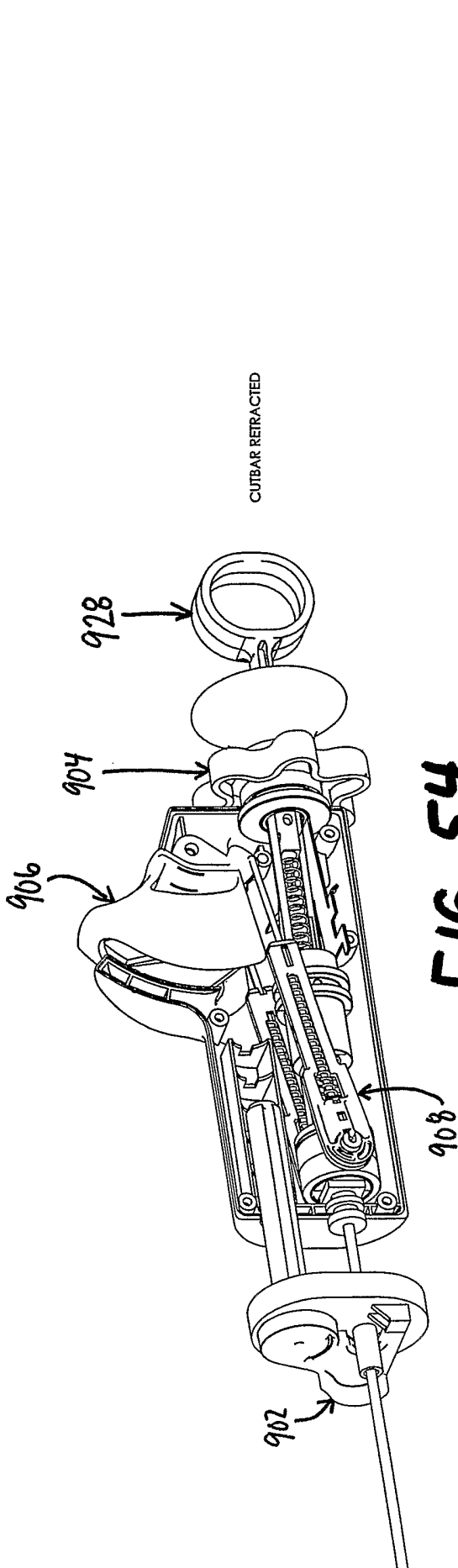

FIG. 54

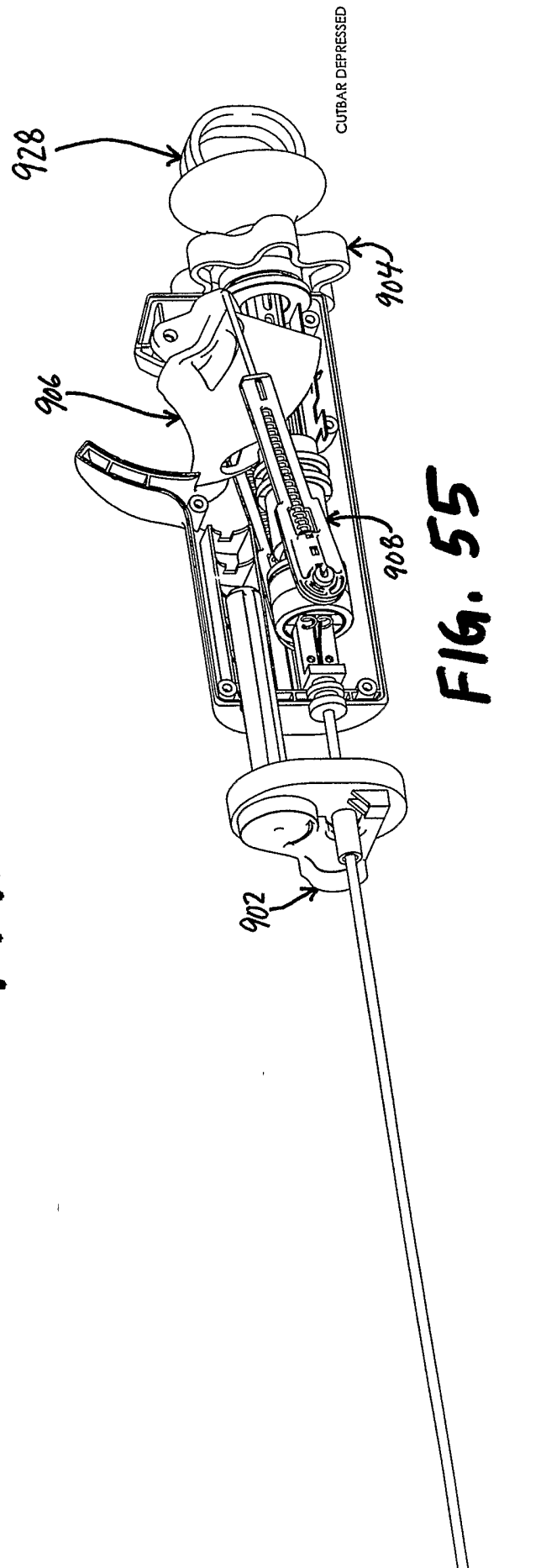

FIG. 55