

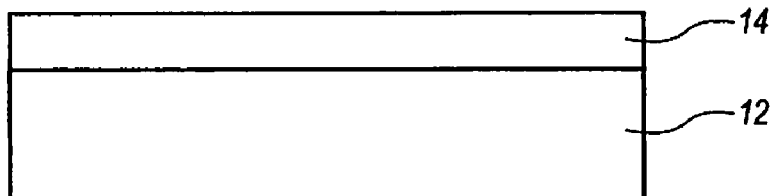

- (51) International Patent Classification: *C09D 133/04* (2006.01)
 - (21) International Application Number: PCT/US2016/049117
 - (22) International Filing Date: 26 August 2016 (26.08.2016)
 - (25) Filing Language: English
 - (26) Publication Language: English
 - (30) Priority Data: 62/211,274 28 August 2015 (28.08.2015) US
 - (71) Applicants: LANDEC CORPORATION [US/US]; 3603 Haven Avenue, Menlo Park, CA 94025 (US). DIVERSEY, INC. [US/US]; 2815 Forest Point Boulevard, Charlotte, NC 28273 (US).
 - (72) Inventors: BITLER, Steven; 444 Univesity Drive, Menlo Park, CA 94025 (US). SCHAFER, Julian; 575 Kanoff Ave, Montara, CA 94037 (US). BOBER, Andrew, M.; 1646 Wisconsin Ave., Racine, WI 53403 (US). SCHWAB-ANDERSON, Brenda; 305 Indian Bend Rd., Burlington, WI 53105 (US). MEYER, Miranda; 1509 92nd St. Unit 85, Sturtevant, WI 53177 (US). STEHLIK, Ellen; 3737 Country Lane, Mount Pleasant, WI 53405 (US). DAYRIT, Richard, M.; 215 Elstar Loop Rd., Simpsonville, SC 29681 (US). OWENSBY, Joseph; 335 Seven Oaks Lane, Spartanburg, SC 29301 (US). CONNER, Howard, D.; 112 Old Bridges Road, Mauldin, SC 29662 (US). MAUER, David; 3117 50th Avenue, Kenosha, WI 53142 (US).
 - (74) Agent: MCDONALD, James; 84 Terrace Ave., Walnut Creek, CA 94597 (US).
 - (81) Designated States (unless otherwise indicated, for every kind of national protection available): AE, AG, AL, AM, AO, AT, AU, AZ, BA, BB, BG, BH, BN, BR, BW, BY, BZ, CA, CH, CL, CN, CO, CR, CU, CZ, DE, DK, DM, DO, DZ, EC, EE, EG, ES, FI, GB, GD, GE, GH, GM, GT, HN, HR, HU, ID, IL, IN, IR, IS, JP, KE, KG, KN, KP, KR, KZ, LA, LC, LK, LR, LS, LU, LY, MA, MD, ME, MG, MK, MN, MW, MX, MY, MZ, NA, NG, NI, NO, NZ, OM, PA, PE, PG, PH, PL, PT, QA, RO, RS, RU, RW, SA, SC, SD, SE, SG, SK, SL, SM, ST, SV, SY, TH, TJ, TM, TN, TR, TT, TZ, UA, UG, US, UZ, VC, VN, ZA, ZM, ZW.
 - (84) Designated States (unless otherwise indicated, for every kind of regional protection available): ARIPO (BW, GH, GM, KE, LR, LS, MW, MZ, NA, RW, SD, SL, ST, SZ, TZ, UG, ZM, ZW), Eurasian (AM, AZ, BY, KG, KZ, RU, TJ, TM), European (AL, AT, BE, BG, CH, CY, CZ, DE, DK, EE, ES, FI, FR, GB, GR, HR, HU, IE, IS, IT, LT, LU, LV, MC, MK, MT, NL, NO, PL, PT, RO, RS, SE, SI, SK, SM, TR), OAPI (BF, BJ, CF, CG, CI, CM, GA, GN, GQ, GW, KM, ML, MR, NE, SN, TD, TG).
- Declarations under Rule 4.17:**
- as to applicant's entitlement to apply for and be granted a patent (Rule 4.17(ii))
 - as to the applicant's entitlement to claim the priority of the earlier application (Rule 4.17(iii))
- Published:**
- with international search report (Art. 21(3))

(54) Title: COATED SUBSTRATES AND COMPOSITIONS FOR COATING SUBSTRATES

FIG. 1



(57) Abstract: A coated floor comprising (1) a flooring substrate, and (2) a solid SCC polymer coating which is adjacent to the substrate and which comprises a sidechain crystalline polymer (SCC polymer) which has an onset of melting temperature, (T_o) of at least 10°C and a peak melting temperature (T_p) of at most 120°C. The SCC polymer coating can be an exterior coating or can be covered by one or more exterior coatings, for example of a commercial flooring finish. When the coated floor is subjected to (i) heat which softens the SCC polymer coating and (ii) physical disturbance, the SCC polymer coating and/or exterior coating(s) can be removed. After that removal, one or more new coatings can be applied to the substrate.

WO 2017/040339 A1

TITLE.**Coated Substrates and Compositions for Coating Substrates.****CROSS-REFERENCE TO RELATED APPLICATIONS.**

5 This application claims priority from, and the benefit of, US Provisional Application No. 62/211,274 filed August 28, 2015. The entire content of that provisional application is incorporated herein by reference for all purposes. This application is also related to (1) the other US and PCT applications filed on the same day as this application and claiming priority from US Provisional

10 Application No. 62/211,274 filed August 28, 2015, (2) US Provisional Application No. 62/211,350, filed August 28, 2015, and entitled Apparatus for Treating Coated Substrates, (3) the US and PCT applications filed on the same day as this application and claiming priority from US Provisional Application No. 62/211,350, (4) US Provisional Application No. 62/211,324 filed August 28, 2015,

15 and entitled Temperature-Releasable Floor Coating System, and (5) the US and PCT applications filed on the same day as this application and claiming priority from US Provisional Application No. 62/611,324 filed August 28, 2015. The entire content of each of those related applications is incorporated herein by reference for all purposes.

20

BACKGROUND OF THE INVENTION.

Surface coating systems protect and enhance the appearance of substrates, such as floors, counter tops, and other areas subjected to traffic or other heavy use. Substrates are prone to wear and deterioration with traffic,

25 such as pedestrian and vehicular traffic.

Sealers can be applied to porous substrates and absorb into the substrate and solidify within the substrate in order to reduce the permeability of the substrate and thereby enhance the durability and appearance of the substrate.

Coatings are applied to porous and nonporous substrates to protect against

30 abrasion, scratching, staining, chemical damage, and other adverse effects.

Coatings can also be designed to significantly enhance the appearance of the

substrate by improving cleanliness, smoothness, reflection, and gloss. Polymer-based floor coatings, in the form of aqueous emulsion or solvent solution, are typically applied to floors with mops or other applicators, and allowed to dry to a hard protective film.

- 5 Polymer-based floor coatings are generally maintained with the use of cleaners and tools, which can include various buffing and burnishing machines. Although floor maintenance programs can be effective, they are expensive. Moreover, as the surface becomes worn or otherwise acquires an unsatisfactory appearance over time, it becomes necessary to entirely remove the coating.
- 10 Stripping can be carried out with chemical strippers and/or mechanical abrasion. Stripping is time-consuming, labor-intensive, potentially hazardous, and can damage the substrate itself, particularly after multiple stripping cycles. Abrasion leaves the floor scoured, reducing the longevity of the flooring substrate.

- Traditional floor finishes, including coatings such as acrylic polymer and/or polyurethane, have been applied to floors. Recent trends in protective floor coatings are to move away from traditional finishes and move toward durable coatings (also referred to as “architectural coatings” because of their permanence and their difficulty of removal) including highly cross-linked coatings, such as those including uv-cured polymers such as uv-cured polyurethane, uv-cured acrylic polymer, crosslinked polyurethane, crosslinked polyurea, crosslinked acrylic polymer, crosslinked epoxy polymer, and polysiloxane.
- 20 Although these coatings can provide enhanced durability relative to traditional floor finishes, they too eventually have to be removed from the floor due to scratching, scuffs, stains, etc. The highly cross-linked structure of these coatings makes them difficult, if not impossible, to remove by any means other than physical abrasion.
- 25

- The establishment and maintenance of floor coatings in commercial buildings subject to public traffic presents challenges. It is undesirable to close part or all of the building during normal operating hours for the stripping of a floor coating, and/or for floor coating installation and maintenance. Moreover, the
- 30

installation of a floor coating system overnight, i.e., during closed hours, must be done in a manner such that when the building opens up for public traffic the next day, the freshly installed floor coating system is safe and durable.

For some time there has been an ongoing search for a floor coating that
5 can be removed without the use of chemical strippers and without the generation of a large amount of dust from abrasion. While it is known that architectural paints and maintenance coatings can be softened and removed with heat to enable mechanical removal, such methods require high energy and high temperatures, and risk damage to the flooring substrate.

10 In addition to the situations specifically described above, there are other situations in which it is desirable to remove an exterior coating from a substrate. Thus, the substrate can be any surface which carries an exterior coating, often referred to as a surface finish. The surface finish can be one which was
15 deliberately applied, as a temporary or permanent cover over the substrate, but which now needs to be removed. Alternatively, the surface finish can be one which was applied by accident, or one which has always been undesired, e.g. graffiti.

As described above, a particular example of such a substrate is a floor. It is important that floors (particularly in commercial establishments, e.g. offices,
20 markets, hospitals and correctional facilities, but also in domestic dwellings) should be safe and sanitary, and have a clean appearance; a shiny appearance is often also desired. The exterior surfaces of many floors are, therefore, conventionally covered with a floor finish, which, in order to maintain the floor in a satisfactory condition, needs to be replaced at regular intervals.

25 Many of the known commercial floor finishes are based on acrylate polymers which are cross-linked using metal ions. These floor finishes have the disadvantage that, in order to remove them, liquid alkaline strippers are conventionally used. Such strippers conventionally have a very high pH and contain sources of alkalinity like sodium or potassium hydroxide or organic
30 amines. As a result, they must carry "Corrosive" label warnings, cannot be discharged as wastewater, and may produce hazardous waste. In addition, such

5 strippers often include 30-90% of solvents such as benzyl alcohol, phenoxyethanol or other glycol ethers, and ethanolamines. Such solvents are strong irritants, are commonly toxic to fish and wildlife, and are frequently not biodegradable. Strippers containing them are, therefore, perceived as ecological hazards because they contain high levels of toxic chemicals. In addition, alkaline strippers can damage the flooring substrate (for example, linoleum may turn brown under high pH conditions.

10 There are other floor finishes which have better chemical resistance than acrylate polymers, but they have the disadvantage that they need to be removed mechanically, e.g. by sanding, which creates dust and which can damage the flooring substrate. There is, therefore, great interest in other techniques that can keep floors clean and remove existing floor finishes, preferably using few or no chemicals. Some so-called "Green" floor strippers have been used or proposed for use. However, such floor strippers often do not work as well as the alkaline strippers, and/or are more costly, and/or require additional labor and training to produce satisfactory results.

15 Many floor maintenance machines use flat, rotating pads to clean and polish floors, and to strip floor finishes; others make use of cylindrical and counter-rotating brushes which are more effective than flat rotating pads for cleaning soil from the pores, grout and defects in the floor. These machines are not effective in removing floor finishes without the assistance of a chemical stripper.

20 Other substrates having an exterior coating which may need to be removed include a wall, a fabric, paper, a polymeric sheet, a woven material such as canvas, a nonwoven material, furniture, a sculpture or a painting. The surface finish can be a finish which was originally useful but which needs to be replaced or removed, e.g. signage, murals, labels, decals, wallpaper or paint, or which is an undesired finish, e.g. graffiti.

25 It is well known to protect and enhance the appearance of substrates, e.g. floors and countertops, by the application of a surface coating. In many cases, the coating is formed by applying to the substrate a polymeric emulsion or solution which dries to a hard protective film.

The surface coating on the floors of commercial establishments needs to be replaced at regular intervals. Many commercial floor finishes are based on acrylate polymers which are cross-linked using metal ions. The replacement of such floor coatings requires the use of alkaline strippers with consequences
5 which are well known to be highly undesirable. Other floor coatings have better wear resistance than acrylate polymers, but must be removed mechanically, e.g. by sanding, which creates dust and which can damage the flooring substrate.

Other surface coatings which may need to be removed are (i) coatings which were originally useful but which now need to be replaced and/or removed,
10 e.g. labels, decals, wallpaper or paint, and (ii) coatings which were never desired, e.g. graffiti.

SUMMARY OF THE INVENTION.

This invention is concerned with coatings which can be removed by
15 without using alkaline strippers. The invention makes use of compositions which (i) comprise a side chain crystalline polymer (abbreviated herein to "SCC polymer"), (ii) can be applied as a liquid to a substrate, for example a flooring substrate, and (iii) after application to the substrate, can be converted into a coating which is (a) solid, (b) is not tacky in the temperature range 15-25°C, and
20 (c) can be triggered by heat. This composition is referred to herein as a "Releasable SCC Polymer Composition", whether it is (i) a liquid which is ready to be applied, or has been applied, to a substrate, or (ii) a solid coating, or (iii) a solid coating which has been triggered by heat.

The term "is not tacky" is used herein to mean that the solid coating
25 exhibits a tack value less than 25 g.cm/sec of force, measured in accordance with ASTM D2979 (see for example US 5,387,450).

The term "triggered by heat" is used herein to mean heating of a solid coating of a Releasable SCC Polymer Composition which converts the SCC polymer from a predominantly crystalline state to a partially or fully amorphous
30 state. In some cases, when the Releasable SCC Polymer Composition is triggered by heat, the SCC polymer becomes a viscous liquid or a flowing gel; in other cases, the SCC polymer softens but has little or no flow.

The term "sidechain crystalline polymer", often abbreviated to SCC polymer or SCCP, is used to denote a polymer which contains a backbone and long side chains which (i) are attached to and extend from the backbone, and (ii) at temperatures below the melting point of the SCC polymer, can crystallize together to render the polymer predominantly crystalline.

The Releasable SCC Polymer Composition can comprise a single SCC polymer or two or more different SCC polymers. In many cases, the Releasable SCC Polymer Composition includes a matrix polymer in which the SCC polymer is dispersed.

The Releasable SCC Polymer Composition can be (i) an "exterior coating", the term "exterior coating" being used to denote a coating which is exposed to the ambient atmosphere, or (ii) an "interior" coating, the term "interior coating" being used to denote a coating which is covered by one or more exterior coatings. The exterior coating or coatings can be composed of a conventional floor finish. The Releasable SCC Polymer Composition can be in direct contact with the substrate or can be separated from the substrate by one or more intermediate ("tie") coatings.

When the solid Releasable SCC Polymer Composition is triggered by heat, the SCC polymer is converted from a predominantly crystalline state to a partially or fully amorphous state, thus reducing the adhesion between the Releasable SCC Polymer Composition and any adjacent surface. This in turn makes it possible for physical disturbance of the exterior coating to convert at least part of the exterior coating into discrete parts which can be removed.

It is preferred that the Releasable SCC Polymer Composition should be heated to a temperature which is greater than the onset of melting point of the SCC polymer (hereinafter abbreviated to T_o) and in many cases to a temperature at least as high as the peak melting temperature of the SCC polymer (hereinafter abbreviated to T_p). Particularly if the difference between the T_o and the T_p of the SCC polymer is large, it is preferable to heat the SCC polymer to a temperature substantially above T_o .

The conversion of the Releasable SCC Polymer Composition into discrete parts can be accomplished in any way. The discrete parts can be removed in any

way. Physical disturbance can be effected by frictional forces which are applied to the exterior coating by a solid and/or by a fluid, for example a heated liquid or steam, and which convert part or all of the exterior coating and optionally part or all of an interior coating into discrete parts which can be removed. When the frictional forces are applied, at least in part, by a solid, the frictional forces can be accompanied by, and/or followed by, the application of a fluid, for example steam and/or air, to the outer surface of the exterior coating and/or to the discrete parts. When the fluid is a liquid, it is preferably a liquid which is environmentally acceptable. The coating or coatings are converted into discrete parts which can for example be small flakes, sheets or strips, and which can be dry or suspended in a liquid. When the parts are dry they can for example be removed by means of a brush and/or a vacuum and/or an air jet, without using any liquid. When a liquid is used, the mixture of liquid and the discrete parts can for example be removed using a wet vacuum and/or squeegee and/or pump.

This invention is chiefly concerned with the use of Releasable SCC Polymer Compositions which can be triggered by heat, which can also be referred to as Heat Releasable SCC Polymer Compositions. However, it is also possible *mutatis mutandis* to coat a substrate with a Cool-Releasable SCC Polymer Composition containing a different type of SCC polymer which can be converted by cooling into a state in which The Cool-Releasable SCC Polymer Composition can be converted by physical disturbance into discrete parts which can be removed from the substrate. The SCC polymer in a Cool-Releasable SCC Polymer Composition can have a freezing point of less than 45°F, or less than 40°F, or less than 35°F, or less than 30°F, or less than 20°F; or from 0° to 45°F, or from 5°F to 40°F, or from 10°F to 35°F, or from 20°F to 35°F, or from 25°F to 35°F, or from 30°F to 35°F. The cooling reduces the SCC polymer to a temperature which is close to or below its freezing point. The SCC polymer preferably has a freezing temperature of less than 15°C and a peak melt temperature T_p greater than 25°C.

Particular aspects of the present invention are summarized below.

First Aspect of the Invention.

In a first aspect this invention provides a coated floor comprising

(1) a flooring substrate, and

5 (2) a Releasable SCC Polymer Composition which (i) is in the form of a solid coating which is adjacent to (but not necessarily in direct contact with) the substrate, (ii) is not tacky in the temperature range 15-25°C, (iii) can be triggered by heat, and (iv) comprises a sidechain crystalline polymer (SCC polymer) which has an onset of melting temperature, T_0 ,
10 which is higher than any temperature to which the substrate will be exposed during normal use and a peak melting temperature, T_p , which is less than any temperature which will damage the substrate, preferably a T_p of at most 120°C.

15 Second Aspect of the Invention.

In a second aspect, this invention provides a method of treating a coated floor according to the first aspect of the invention, the method comprising comprises subjecting the solid coating of the Releasable SCC Polymer
20 Composition to heat and physical disturbance which removes at least part of the coating of the Releasable SCC Polymer Composition and/or at least part of an exterior coating on top of the Releasable SCC polymer coating, and which optionally also removes at least part of an interior coating between the substrate and the coating of the Releasable SCC Polymer Composition.

25 Third Aspect of the Invention.

In a third aspect, this invention provides a liquid Releasable SCC Polymer Composition comprising (1) an SCC polymer which has an onset of melting
30 temperature, T_0 , of at least 27°C. and a peak melting temperature (T_p) of at most 120°C. and (2) a matrix polymer.

Fourth Aspect of the Invention.

A fourth aspect of the invention provides a method for preparing a coated

floor according to the first aspect of the invention, the method comprising

(1) applying a liquid Releasable SCC Polymer Composition to a flooring substrate, and

(2) after step (1), solidifying the liquid Releasable SCC Polymer Composition in contact with the flooring substrate.

5

Fifth Aspect of the Invention.

A fifth aspect of the invention provides a method for preparing a coated floor according to the first aspect of the invention, the method comprising

10

(1) providing a substrate which has an exterior solid coating of a Releasable SCC Polymer Composition, and

(2) applying a polymeric composition which is not a Releasable SCC Polymer Composition, for example a composition which does not comprise an SCC polymer, e.g. a floor finish, to the exterior coating.

15

Sixth Aspect of the Invention.

A sixth aspect of the invention provides apparatus for heating and physically disturbing a coating on a coated floor according to the first aspect of the invention. The apparatus preferably comprises (a) means for heating the coating to trigger the coating of the Releasable SCC Polymer Composition and (b) a solid contact agitator for disintegrating at least some of the coating. The apparatus can also comprise (c) means for delivering steam and/or water or another fluid to assist in the disintegration and/or to wash away the products of the disintegration.

20

BRIEF DESCRIPTION OF THE DRAWINGS.

25

The invention is illustrated in the accompanying illustrative drawings which are diagrammatic and not to scale and in which

Figure 1 is a cross-section through a part of a floor substrate 12 which covered by a coating of a Releasable SCC Polymer Composition 14,

30

Figure 2 is the same as Figure 1, except that there is a coating 18 of an acrylic floor finish over the coating 14, and

Figure 3 is the same as Figure 2 except that there is a tie layer 20 between the substrate and the coating 14.

FIG. 4 illustrates a perspective view of a first manually-controlled, electrically-powered coating removal machine for removing a heat-releasable floor coating.

FIG. 5 illustrates a schematic of a bottom view of the brush assembly illustrated in FIG. 4.

FIG. 6 illustrates a perspective view of a first alternative manually-controlled, electrically-powered coating removal machine for removing a heat-releasable floor coating.

FIG. 7 illustrates a perspective view of a frictional heating member for use in the alternative manually-controlled, electrically-powered coating removal machine for removing a heat-releasable floor coating.

FIG. 8 illustrates a perspective view of a second alternative manually-controlled, electrically-powered coating removal machine for removing a heat-releasable floor coating.

FIG. 9 illustrates a perspective view of an electrically-powered, steam-heating, walk-behind coating removal machine for removing a heat-releasable floor coating.

DETAILED DESCRIPTION OF THE INVENTION.

In the Summary of the Invention above and in the Detailed Description of the Invention, the Examples, and the Claims below, and in the attached drawings, reference is made to particular features (including method steps) of the invention. It is to be understood that the disclosure of the invention in this specification includes all appropriate combinations of such particular features. For example, where a particular feature is disclosed in the context of a particular aspect or embodiment of the invention, or a particular claim, that feature can also be used, to the extent appropriate, in combination with and/or in the context of

other particular aspects and embodiments of the invention, and in the invention generally.

The term "comprises" and grammatical equivalents thereof are used herein to mean that other elements (i.e. components, ingredients, steps etc.) are optionally present. For example, a structure "comprising" (or "which comprises") components A, B and C can contain only components A, B and C, or can contain not only components A, B and C but also one or more other components.

The term "consisting essentially of" and grammatical equivalents thereof is used herein to mean that other elements may be present which do not materially alter the disclosed invention.

Where reference is made herein to a method comprising two or more defined steps, the defined steps can be carried out in any order or simultaneously (except where the context excludes that possibility), and the method can include one or more other steps which are carried out before any of the defined steps, between two of the defined steps, or after all the defined steps (except where the context excludes that possibility).

The term "at least" followed by a number is used herein to denote the start of a range beginning with that number (which may be a range having an upper limit or no upper limit, depending on the variable being defined). For example, "at least 1" means 1 or more than 1, and "at least 80%" means 80% or more than 80%.

The term "at most" followed by a number is used herein to denote the end of a range ending with that number (which may be a range having 1 or 0 as its lower limit, or a range having no lower limit, depending upon the variable being defined). For example, "at most 4" means 4 or less than 4, and "at most 40%" means 40% or less than 40%.

When, in this specification, a range is given as "(a first number) to (a second number)" or "(a first number) - (a second number)", this means a range whose lower limit is the first number and whose upper limit is the second number. For example, "from 2 to 16" or "2-16" means a range whose lower limit is 2 and whose upper limit is 16.

The numbers given herein should be construed with the latitude appropriate to their context and expression.

The terms "a", "an" and "the" before an item are used herein to mean that there can be a single such item or two or more such items, unless the context makes this impossible.

The term "plurality" is used herein to mean two or more.

In describing and claiming the invention below, the following abbreviations, definitions, and methods of measurement (in addition to those already given) are used.

Parts and percentages are by weight, unless otherwise noted.

Temperatures are in degrees centigrade, unless otherwise noted.

Particle sizes given herein are median particle sizes measured by a Horiba LA-910 laser light scattering analyzer.

The viscosities given herein were measured at 20°C using a Brookfield LVF viscometer with spindle #3 at 60 RPM. The abbreviation T_o is used to denote the onset of melting and the abbreviation T_p is used to denote the peak crystalline melting point, both measured by means of a differential scanning calorimeter (DSC) at a rate of 10°C/minute and on the first heating cycle. T_o and T_p are measured in the conventional way well known to those skilled in the art. Thus T_p is the temperature at the peak of the DSC curve, and T_o is the temperature at the intersection of the baseline of the DSC peak and the onset line, the onset line being defined as the tangent to the steepest part of the DSC curve below T_p .

The molecular weights given herein were measured by gel permeation chromatography using a Perkin-Elmer Series 200 Autosampler and Binary LC pump with 3 Phenomenex GPC columns in two Series 200 Peltier Column Ovens followed by a Series 200a refractive index detector and ASTRA software.

The term "VCT tile" (a commercial acronym for vinyl composition tile) is used herein to denote a floor tile which is composed primarily of ground limestone, vinyl resin (typically a polymer of 95% vinyl chloride and 5% vinyl acetate) and plasticizer (typically one or more phthalate esters); ASTM F1066-04

sets out certain requirements for VCT tiles such as dimensional stability and impact and heat resistance.

The SCC Polymers Used in This Invention.

5 The SCC polymers used in this invention have an onset of melting temperature, T_0 , which is higher than any temperature to which the substrate will be exposed during normal use and a peak melting temperature (T_p) which is less than any temperature which will damage the substrate, preferably a T_p of at most 120°C.

10 The SCC polymer may be an acrylic polymer (including those derived from one or more monomers such as substituted and unsubstituted acrylates, methacrylates, fluoroacrylates, acrylamides, methacrylamides), vinyl polymer, polyester (including polymers formed from vinyl esters), polyimide (including maleimides), polyolefin (including α -olefins), polystyrene (including p-alkyl
15 styrenes), polyether (including alkylvinyl ethers), polyalkylene oxide (including alkylethylene oxides), polyphosphazene (including alkyl phosphazenes), amino acid polymer, polyisocyanate, polyurethane, polysilane, polysiloxane, and polyether. These polymers have long chain crystallizable groups.

 The SCC polymer can be replaced in whole or part by a different
20 crystalline polymer having desired properties, for example polymers in which the crystallinity results exclusively or predominantly from the polymer backbone, e.g. polymers of alpha-olefins containing 2-12, preferably 2-8, carbon atoms, and other polymers such as polyesters, polyamides, and polyethylene oxides, e.g. poly tetrahydrofuran.

25 In various embodiments of the invention, the SCC polymer has one or any possible combination of one or more of the following characteristics: –

(a) the SCC polymer has a T_0 of at least 10°C, or at least 15°C, or at least 27°C, or at least 35°C, or at least 40°C,

(b) the SCC polymer has a T_p of at most 80°C, preferably at most
30 60°C, particularly at most 50°C.,

- (c) the SCC polymer has a T_p and a T_0 , measured in degrees centigrade, such that the value of $(T_p - T_0)$ is less than $T_p^{0.7}$, preferably less than 25°C, preferably less than 20°C, particularly less than 15°C,
- (d) the SCC polymer has a weight average molecular weight of at most 100,000 Da, preferably at most 50,000 Da, particularly at most 20,000 Da, and in some applications less than 10,000 Da,
- (e) the SCC polymer has been prepared by an emulsion polymerization process which produces particles having a size of 0.07 to 0.5 μm , particularly 0.1 to 0.25 μm ,
- (f) the SCC polymer comprises units derived from one or more n-alkyl acrylates or methacrylates in proportions by weight such that the average length of the n-alkyl groups is 16-20, for example 16-18, carbon atoms, the n-alkyl groups for example containing 8-22 carbon atoms, and the polymer for example containing 90 to 98%, e.g. 94 to 97%, by weight of the units derived from one or more n-alkyl acrylates.
- (g) the SCC polymer comprises 90-98%, e.g. 94-97%, by weight of units derived from octadecyl acrylate and hexadecyl acrylate, the ratio of octadecyl acrylate to hexadecyl acrylate units being for example 16 to 2.
- (h) the SCC polymer contains, for example in amount greater than 1%, for example 1-4%, e.g. 2-4%, or 1-3%, or 1-2%, units derived from (i) a comonomer containing a carboxylic group, e.g. methacrylic acid, and/or (ii) a comonomer containing a hydroxyl group, e.g. hydroxyethyl acrylate, hydroxyethyl methacrylate hydroxypropyl acrylate or hydroxypropyl methacrylate.
- (i) the SCC polymer has a heat of fusion of at least 20 Joules/g

The SCC polymer preferably contains repeating units derived from one or more acrylate or methacrylate esters of straight chain fatty alcohols containing 8 to 22 carbon atoms and optionally repeating units derived from other co-polymerizable acrylate monomers. Preferred comonomers are monomers containing carboxylic groups (e.g. methacrylic acid) and monomers containing hydroxyl groups (e.g. hydroxyethyl acrylate, hydroxyethyl methacrylate,

hydroxypropyl acrylate and hydroxypropyl methacrylate). The presence of units derived from these preferred comonomers, typically in amount 2-4%, contributes to improved film formation. In some embodiments, the SCC polymer contains units derived from methacrylic acid in amount up to 1% by weight of the polymer.

5 In other embodiments, the SCC polymer contains units derived from methacrylic acid in amount greater than 1%, for example 1-4%, or 1-3%, or 1-2%.

The SCC polymer often also contains the residue of a chain transfer agent, e.g. n-dodecyl mercaptan or butyl mercaptopropionate or methyl benzyl alcohol, which was used during the polymerization in order to control the

10 molecular weight of the polymer.

The monomers can be reacted together by random, stepwise or block copolymerization.

The SCC polymer preferably contains little or substantially no low molecular weight oligomers or unreacted monomers. For example, the polymer

15 preferably contains less than 2000 ppm of unreacted monomers.

Other SCC polymers can be produced using monomers which are not acrylate or methacrylates, e.g. polymers derived from vinyl esters of fatty acids, copolymers of ethylene and/or 1-alkenes, and polymers derived from other long chain alkyl monomers, for example as described in the US patents incorporated

20 by reference herein.

In an embodiment, the SCC polymer is present in combination with a second polymeric ingredient which becomes covalently linked, e.g. crosslinked, to provide one or more desired properties. The second polymer may be for example an amorphous polymer or a crystalline polymer having a melting point

25 higher or lower than T_p .

In an embodiment, the SCC polymer comprises a thermoplastic elastomer, for example one in which an active chemical moiety is attached to the hard block, and the soft blocks have a toughening effect on the final product. For example, the thermoplastic elastomer can include SCC hard blocks and

30 amorphous soft blocks. The SCC hard blocks can for example be derived from SCC polymers as described above. The amorphous soft blocks can for example have a T_g of -60 to 150°C, or from -60 to 120°C. Suitable soft blocks can for

example be derived from one or more of butyl acrylate, ethyl hexylacrylate, and butadiene.

The phrases "cool releasable coating," "cool-releasable coating," both refer to a coating having a cool-releasable component having a freezing point temperature (T_f) at or below 20°C. The T_f of the cool-releasable component may correspond with the T_o of the cool-releasable component. In an embodiment, the cool-releasable component is polymeric. In an embodiment, the cool-releasable component is a side-chain crystalline polymer. Upon cooling the at least one cool-releasable coating to a temperature $\leq T_f$, coating removal can be carried out by subjecting the coating to agitation while cooled.

In some embodiments the SCC polymers used in this invention are produced by emulsion polymerization. The polymers prepared by emulsion polymerization preferably have a particle size of 0.07 to 0.5 μ , particularly 0.1 to 0.25 μ , particularly 0.1-0.15 μ m. However, higher particle sizes, e.g. up to 1 μ , can be used if the polymer is present in a formulation containing appropriate amounts of other ingredients to ensure film formation. The larger size SCC polymer particles may alternatively be created by mechanical emulsification of melted SCC polymers prepared by bulk or solution polymerization processes. When the SCC polymer is applied to the substrate as a solution in a solvent or is melt-applied, the particle size of the SCC polymer is less relevant.

SCC polymers are in themselves known. Publications describing SCC polymers include U.S. Patent Nos. 4,830,855, 5,120,349, 5,156,911, 5,254,354, 5,387,450, 5,412,035, 5,469,867, 5,665,822, 5,752,926, 5,783,302, 5,807,291, 5,826,584, 6,199,318, 6,255,367, 6,376,032, 6,492,462, 6,540,984, 6,544,453, 6,831,116, 6,989,417, 7,101,928, 7,169,451, 7,175,632, 7,449,511, 7,182,951, 7,291,389 and 8,114,883; J. Poly. Sci. 60, 19 (1962), J. Poly. Sci. (Polymer Chemistry) 7, 3053 (1969), 9, 1835, 3349, 3351, 3367, 10, 1657, 3347, 18, 2197, 19, 1871, J. Poly. Sci. Poly-Physics Ed 18 2197 (1980), J. Poly. Sci. Macromol. Rev, 8, 117 (1974), Macromolecules 12, 94 (1979), 13, 12, 15, 18, 2141, 19, 611, JACS 75, 3326 (1953), 76; 6280, Polymer J 17, 991 (1985); and Poly. Sci USSR 21, 241 (1979). The entire disclosure of each of those United States Patents and publications is incorporated in this specification by reference.

Preparation of the SCC Polymers.

Those skilled in the art of the SCC polymers are conversant with the known methods for preparing SCC polymers. Reference may be made, for example, to the patents and publications incorporated by reference, for example US 6,540,984 and US 7,175,832 describing emulsion polymerization methods. Those skilled in the art, having regard to their own knowledge and the disclosure in this specification, will have no difficulty in preparing SCC polymers which are useful in this invention.

Releasable SCC polymer coatings Containing Additional Ingredients.

When the SCC polymer has been produced by emulsion polymerization, it is difficult to make the SCC polymer particles coalesce when the SCC polymer is dried at temperatures less than T_0 , to form a continuous and crack-free coating.

To avoid or limit the need to dry the SCC polymer emulsion at an elevated temperature, the liquid SCC Polymer Composition applied to the substrate preferably contains additional ingredients which make it easier to form a thin, continuous and crack-free coating containing the SCC polymer. The additional ingredients may include, but are not limited to, non-crystalline polymers, water, solvents, diluents, wetting agents, thickeners, plasticizers and/or other additives that aid in the application, spreading and film formation of the coating.

The choice of additional ingredients preferably takes into account the physical and chemical properties of the surface of the substrate on which the Releasable SCC Polymer Composition is to be formed and the physical and chemical properties of any other coating later applied to the solid Releasable SCC Polymer Composition.

Preferably one of the additional ingredients which remains in the final coating is a "matrix polymer". The term "matrix polymer" is used in this specification to denote an amorphous polymer which, preferably without, but optionally including, plasticizers or coalescing solvents, is a film-forming polymer. The matrix polymer may comprise one or more film-forming polymers selected from the group consisting of polyurethanes, polyacrylates, polysiloxanes,

polysilazanes, polyesters, polyamides, polyureas, epoxy polymers, vinyl polymers, polyethers, polyaldehydes, polyketones and polycarbonates. The matrix polymer may comprise at least one member selected from the group consisting of polyurethane made from polyester diol, styrene/acrylic copolymer, polyurethane/acrylic hybrid polymer, polysiloxane made from multi-functional alkoxy silane.

In some embodiments, the matrix polymer is an acrylic polymer, for example a styrene-acrylic polymer, the polymer containing 0-25%, e.g. 1-25% or 0-20%, e.g. 1-20%, or 0-15%, e.g. 1-15%, or 0-5%, e.g. 1-5% of units derived from one or more monomers containing carboxylic groups, for example methacrylic acid.

In some embodiments, the matrix polymer is a styrene-acrylic polymer, or another acrylic polymer, the polymer being present, in the liquid Releasable SCC Polymer Composition in the form of an emulsion. The styrene-acrylic polymer or other acrylic polymer can be a core shell styrene-acrylic polymer or another core shell acrylic polymer.

The matrix polymer can for example be (i) a polymer which is not cross-linked and which has a molecular weight up to 1 million or (ii) a cross-linked polymer which has a molecular weight of greater than 1 million, including a gel with an infinite molecular weight.

The matrix polymer can for example have (i) an average particle size of 0.05-0.2 μm , e.g. 0.05-0.10 μm and/or (ii) an acid monomer content of 0-20 %, or 0.5%, e.g. 1-5% and/or (iii) a pH of 2-10, or 5-9, or 2-6..

In some embodiments, the matrix polymer has an MFFT below 20°C. Examples of such matrix polymers include Raykote 1610 (50% NV, 7°C MFFT), Raytech 22053 (40.9 % NV, 2 °C MFFT) and Rayflex 610 (58% NV, 0°C MFFT). In other embodiments, the matrix polymer has a higher MFFT. The MFFT of a polymer can be measured by ASTM D2354.

In some embodiments, the matrix polymer is a commercial floor finish or a modified commercial floor finish, for example modified to increase the carboxylic acid content thereof.

In some embodiments, the solid coating of the Releasable SCC Polymer Composition contains (a) 30-80%, for example 40-70% or 50-60%, of the SCC polymer and (b) 20-70%, for example 30-60% or 40-50%, of a matrix polymer. However, the invention includes the possibility that the Releasable SCC Polymer
5 Composition contains 1-99% of the SCC polymer.

In other embodiments, the solid coating of the Releasable SCC Polymer Composition contains (a) 10-60 %, for example 15-50 % or 20-40 %, of the SCC polymer and (b) 40-90 %, for example 50-85 % or 60-80 %, of a matrix polymer.

Other additional ingredients which are optionally present in the liquid

10 Releasable SCC Polymer Composition include (i) water and/or other ingredients, e.g. solvents, which evaporate after the Releasable SCC Polymer Composition has been applied to, and dried on, the substrate, and which are not, therefore, present in the final coating, and (ii) one or more other ingredients which remain in the final coating. The additional ingredients can include (i) thickeners, to
15 decrease the tendency of a low solids coating to crawl and retract from the edges of the substrate due to poor wetting, for example in amount 0.1-0.2% solids on the total formulation, e.g. Acrysol TT-935, Acrysol TT-615 and the other hydrophobically-modified alkali swellable emulsions, (ii) surface tension reducers, for example in amount 0.1-0.4% solids on the total formulation, e.g. Fluorad FC-
20 4432, Fluorad FC-129, Capstone FS-65 and Zonyl FSO, (iii) wetting and anti-foaming agents, for example in amount 0.05-0.25% solids on the total formulation, e.g. Surfynol 104A, Surfynol 104PA and Surfynol 485W, and (iv) water-soluble solvents to improve film spreading, substrate wetting and interfacial
25 adhesion, for example in amount 1-5% of the composition as it is applied to the substrate, e.g. glycol ethers and alcohols

Thus, the Releasable SCC Polymer Composition, at the time it is applied to the substrate as a liquid, preferably contains other ingredients including, but not limited to, one or more matrix polymers, water, one or more surfactants, and one or more cosolvents. The Releasable SCC Polymer Composition can also
30 contain additional ingredients which remain in the solid coating of the Releasable SCC Polymer Composition, and which improve the compatibility between the

coating and the substrate to which it is applied and/or an exterior coating which is applied on top of the solid coating of the Releasable SCC Polymer Composition.

In particular embodiments of the invention, the Releasable SCC Polymer Composition comprises a matrix polymer having one or any possible combination of two or more of the following optional characteristics: –.

(a) the matrix polymer has a minimum film forming temperature (MFFT) which is at most 20°C,

(b) the matrix polymer has a minimum film forming temperature (MFFT) which is at least 20°C

(c) the matrix polymer is miscible with water,

(d) the matrix polymer is an acrylic or styrene-acrylic polymer prepared by emulsion polymerization, for example a cross-linked styrene-ethylhexylacrylate-methacrylic acid polymer, a styrene-butylacrylate--methacrylic acid polymer, a styrene-butylacrylate-methylmethacrylate-methacrylic acid polymer, or an isobutyl methacrylate-methylmethacrylate-hydroxyethyl acrylate,

(e) the matrix polymer is composed of particles which are smaller than the particles of the SCC polymer, and

(f) the matrix polymer forms a continuous phase in which the SCC polymer is dispersed in the form of particles.

Additional Details of the Releasable SCC Polymer Composition and Other Coatings.

In some embodiments of the invention, the solid coating of the Releasable SCC Polymer Composition has a thickness of less than 10 µm, preferably less than 2 µm, e.g. less than 1 µm. In some embodiments of the invention, the solid coating of the Releasable SCC Polymer Composition has a thickness of at least 0.001 inch, or at least 0.0015 inch, or at least 0.002 inch, or at least 0.003 inch. In some embodiments of the invention, the solid coating of the releasable SCC polymer composition has a thickness of 0.05-05 mil, or 0.1-2 mil, or 0.1-1 mil, or 0.1-0.5 mil, or 0.1-0.3 mil.

There can be two or more solid coatings of the Releasable SCC Polymer Composition. When there are two or more Releasable SCC polymer coatings, they have preferably been applied separately and optionally can be separated by one or more polymeric coatings which are not composed of a Releasable SCC Polymer Composition, and optionally do not contain an SCC polymer.

In some embodiments of the invention, the solid coating of the Releasable SCC Polymer Composition directly contacts the flooring substrate, and in other embodiments, the solid coating is separated from the flooring substrate by an intermediate ("tie") layer, for example a tie layer comprising a polymeric composition which is not composed of a releasable SCC polymer composition and optionally does not include an SCC polymer. The tie layer can make it easier to form the Releasable SCC polymer coating on the substrate and/or to subsequently remove part or all of the Releasable SCC polymer coating.

Particularly if the surface of the substrate has a porous, matte or otherwise non-uniform and non-glossy surface, there is preferably a tie layer which is between the substrate and the solid coating of the Releasable SCC Polymer Composition. This can make it easier to form a uniform coating of the Releasable SCC Polymer Composition, and/or can reduce the number of outer coats which need to be applied over the solid coating of the Releasable SCC Polymer Composition in order to achieve a satisfactory appearance. Preferably the tie layer has sufficient abrasion resistance to ensure that it remains in place after the Releasable SCC polymer coating has been removed. Polyurethane compositions have been found to be particularly useful as base coats.

Exemplary tie layers include traditional floor finishes, including crosslinked and non-crosslinked coatings such as acrylic polymer (including uv-cured acrylic polymer), polyurethane (including uv-cured polyurethane and polyurethane that is not uv-cured), polyurea, epoxy polymer (including uv-cured epoxy polymer), polysiloxane, vinyl polymer, styrene-butadiene polymer, as well as factory-applied coatings, concrete treatments, penetrating sealers, densifiers and other suitable coatings and treatments known to those skilled in the art. A tie layer may have a dry weight coating thickness of about 0.01 mil to about 100 mil.

In many embodiments of the invention, there is an exterior coating on top of the solid coating of the Releasable SCC polymer coating, for example an exterior coating which comprises one or more coatings of a commercially available flooring finish. The exterior coating (which can also be termed a wear coating) can have a thickness of 0.05-15 mils, or 0.1-10 mils, or 0.2-8 mils, or 0.3-7 mils, or 0.4-6 mils, or 0.5-5 mils, or 0.5-3 mils, or 0.5-2 mils or 0.5-1 mils. The wear coating can exhibit an average Konig hardness value of at least 60 seconds, or at least 70 seconds, or 100-200 seconds. The wear coating can be a coating formed from a coating composition as disclosed in US 5,977,228, International Publication WO 1999/000459 or International Publication WO 2012/162641. The entire content of each of those publications is incorporated herein by reference for all purposes.

In some cases, the solid coating of the Releasable SCC Polymer Composition has a transparency of at least 10%, or at least 20%, or at least 30%, measured in accordance with ASTM D1746-97, and a percent haze of less than 20%, or less than 15%, or less than 10%, or less than 7%, or less than 5%, measured in accordance with ASTM D 1003-00. The solid coating can be substantially free of dyes, pigments and other colorants. The solid coating can be clear, for example with a Gardner color no greater than 1. In other cases, the solid coating can be water white. In other cases, the coating can be opaque.

When there is more than one coating on the substrate, preferably each coating is allowed to solidify before a further coating is applied. The coatings may have the same or different compositions.

Possible multilayer coating systems are set out below, which use the following abbreviations.

FS is a flooring substrate.

BL is a base layer directly adhered to the flooring substrate.

PL is a primer layer directly adhered to the flooring substrate

TRL is a Releasable SCC polymer composition.

TRL₁ is a first Releasable SCC polymer composition.

TRL₂ is a second Releasable SCC polymer composition.

TRL₃ is a second Releasable SCC polymer composition.

WL is a wear layer.

WL₁ is a first wear layer.

WL₂ is a second wear layer.

WL₃ is a second wear layer.

5

Possible multilayer coating systems are

FS-TRL-WL.”

FS-BL-TRL-WL.

FS-PL-TRL-WL.

10

FS-PL-BL-TRL-WL.

FS-TRL₁-WL₁-TRL₂-WL₂.

FS-BL-TRL₁-WL₁-TRL₂-WL₂;

FS-PL-TRL₁-WL₁-TRL₂-WL₂;

FS-PL-BL-TRL₁-WL₁-TRL₂-WL₂;

15

FS-TRL₁-WL₁-TRL₂-WL₂-TRL₃-WL₃;

FS-BL-TRL₁-WL₁-TRL₂-WL₂-TRL₃-WL₃;

FS-PL-TRL₁-WL₁-TRL₂-WL₂-TRL₃-WL₃; and

FS-PL-BL-TRL₁-WL₁-TRL₂-WL₂-TRL₃-WL₃.

Additional “TRL_x-WL_x” layer “cycles” can be added on to any degree desired. In coatings having multiple wear layers, a TRL is provided between each of the wear layers. Optionally, a TRL can also be provided between the substrate and the wear layer closest to the substrate.

Having multiple cycles of TRLs and WLs can (a) enable stripping one cycle at a time to reveal a fresh wear layer without having to re-coat, and/or (b) be provided as relatively thin layers, allowing the wear layer to be more easily broken up and removed in the stripping process, with either all layers stripped at once, or the stripping of only a single cycle at a time, and/or (c) be provided with at least one TRL to allow different methods for removing one TRL at a time, without removing more than one TRL.

30 A multi-cycle system can possess different TRLs.

When there are multiple coatings on the substrate, the combined thickness of the coatings can be, for example, 3-10 mils, or 3.1-9 mils, or 3.2-8 mils, or 3.42 7 mils, or 3.52 6 mils.

The finished coating on the substrate can have (i) a high gloss appearance, i.e. a 60° gloss of at least 60%, measured in accordance with ASTM D1792, or (ii) a satin gloss appearance, i.e. a 60° gloss of 40-60%, measured in accordance with ASTM D1792, or (iii) a matte appearance, i.e. a 60° gloss of less than 40%, measured in accordance with ASTM D1792, or (iv) a transparency of at least 10%, or at least 20%, or at least 30%, measured in accordance with ASTM D 1746-97 and a percent haze of less than 20%, or less than 15%, or less than 10%, or less than 7%, or less than 5%, measured in accordance with ASTM D1003-00, or (v) opaque, or (vi) clear with a Gardner color no greater than 1, e.g. water-white.

The finished coating on the substrate can have a coefficient of friction greater than or equal to 0.5, measured in accordance with ASTM D2047-11 "Standard Test Method for Static Coefficient of Friction of Polish-Coated Flooring Surfaces As Measured by the James Machine".

The Substrates Used in This Invention.

The substrate which carries the Releasable SCC polymer coating can be of any kind, but the invention is particularly useful when the substrate is a fixed floor surface or a substrate, for example a VCT tile or linoleum, which can be secured to a fixed substrate to provide a fixed floor surface. Other substrates include food preparation surfaces, kitchen surfaces, bathroom surfaces, desks, tables etc., as well as vertical surfaces such as walls, Windows and the like, as well as irregular surfaces such as food preparation equipment, vessels, tanks, parts etc. the substrate can be made of a large variety of materials, including but not limited to plastic, linoleum, vinyl tile (particularly vinyl composition tile) find out asbestos, stone (particularly marble, granite, terrazzo, travertine, slate as well as engineered stone) concrete, ceramic, glass, wood (including engineered wood, metal and rubber.

In one embodiment of the invention, the substrate is a vinyl composition tile (VCT). Such tiles are well known and are composed primarily of ground limestone, vinyl resin (typically a polymer of 95% vinyl chloride and 5% vinyl acetate) and plasticizer (typically one or more phthalate esters); ASTM F1066-04 sets out certain requirements for VCTs such as dimensional stability and impact and heat resistance.

VCTs are frequently supplied with an upper surface coating of a thin (about 0.2 mil thick) acrylic lacquer sealer. Often, after the tiles have been secured to the rigid substrate, they are given three or four coatings of a conventional acrylic VCT finish, in order to produce a desirable glossy and wear-resistant surface.

The Releasable SCC Polymer Composition can be formed directly on a VCT, whether or not the VCT has a surface coating of an acrylic lacquer sealer. After the solid coating of the Releasable SCC polymer composition has been formed, one or more coats, e.g. 2-4 coats, of a conventional floor finish can optionally be applied so that the finished floor has desired durability and appearance.

Formation of the Solid Coating of the Releasable SCC Polymer

Composition.

The Releasable SCC polymer coating is preferably a solid coating which was formed by (A) depositing on the substrate a coating of a liquid Releasable SCC Polymer Composition which contains (i) an SCC polymer (ii) a matrix polymer, and (iii) water and optionally another solvent which can be removed by drying, and (B) after step (A), drying the coating deposited on the substrate.

Alternatively, the solid coating of the Releasable SCC Polymer Composition can be formed by (1) depositing on the substrate a liquid composition comprising the SCC polymer dissolved in a solvent, followed by removal of the solvent, or (2) depositing on the substrate a coating of a Releasable SCC Polymer Composition which is at a temperature above the T_p of the SCC polymer, followed by cooling, or (3) depositing on the substrate a coating of a liquid Releasable SCC Polymer Composition and otherwise

converting the liquid composition to a solid form, for example using ultraviolet light or other electromagnetic radiation, electron beam radiation or chemically-induced hardening.

5 **Heat Treatment And Physical Disturbance of the Releasable SCC Polymer Composition.**

In order to remove part or all of the solid coating of the Releasable SCC Polymer Composition and/or part or all of an exterior coating on top of the solid coating of the Releasable SCC Polymer Composition, the coated substrate is
10 subject to heat which triggers the Releasable SCC Polymer Composition and to physical disturbance.

Any method of heating can be used. For example, the heating can be dry heating, supplied for example by a hot metal surface and/or hot air, and/or heating which is delivered by and/or accompanied by steam and/or liquid water,
15 and/or infrared heating, and/or microwave heating, and/or ultraviolet heating, and/or ultrasonic heating and/or frictional heating. The Releasable SCC Polymer Composition can include a component which enhances the response of the coating to a particular type of radiation.

The physical disturbance of the coating or coatings results in (A) when the
20 Releasable SCC Polymer Composition is the exterior coating, discrete parts of the Releasable SCC Polymer Composition, or (B) when there is an exterior coating of a different polymer composition, (i) discrete parts which comprise part or all of the exterior coating but little or none of the Releasable SCC Polymer Composition, or (ii) discrete parts which comprise part or all of the exterior
25 coating and part of the Releasable SCC Polymer Composition, or (iii) substantially all of the exterior coating and substantially all of the Releasable SCC polymer composition.

In some embodiments, at least part of the physical disturbance of the coating(s) is provided by a stream of water. The water can be emitted from a
30 nozzle under high pressure, for example at a pressure of 500-30,000 psi, or 1000-20,000 psi, or 1200-15,000 psi, or 1500-10,000 psi, 1500-8000 psi, or 2000-6000 psi. The water can be emitted from the nozzle at a rate of 2-45,

3.7-37, 5-30, or 7-25, or 8-20, or 9-18, or 10-15, liters per minute The water can travel 0.5-75 cm, or 2-25 cm, or 3-20 cm, or 4-15 cm, before contacting the coating. The water can be at a temperature of 27-120°C or 30-105°C, or 40-100°C, or 45-95°C, or 50-90°C, or 55-85°C, or 60-80°C.

5 In some embodiments, at least part of the physical disturbance can be provided by (i) a floor finishing or cleaning machine which has flat, rotating pads and/or cylindrical and counter-rotating brushes and which can also deliver sufficient heat to trigger the Releasable SCC polymer coating, or (ii) a floor finishing machine which has flat rotating pads and/or cylindrical and counter-rotating brushes and which is used in conjunction with a separate machine which can deliver sufficient heat to trigger the Releasable SCC polymer coating, or (iii) a steam cleaning machine, or any combination of such machines. Abrasion of the coating(s) can make use of grits of 50-3000, 100-2500, 220-2500, 500-2000, 600-1500, or 800-1200.

15 In some embodiments, at least part of the physical disturbance of the coating(s) is provided by a device comprising a plurality of elastomeric members which protrude from a head and which contact the exterior coating. The head can be powered for circular motion, and/or linear motion, or random motion. The speed at the tips of the elastomeric members can for example be 20-1000, or 40-700, or 50-500, or 60-400, or 70-300 m/minute. The elastomeric members can have a ratio of length to average cross-sectional area of 0.5:1-20:1, or 1:1- 15:1, or 2:1- 12:1, or 3:1- 10:1, or 4:1- 10:1, or 5:1- 10:1. The elastomeric members can for example have a Shore A hardness of 20-100, or 35-90, or 50-19, or 60-90, or 70-90, or 80-90. The elastomeric members can for example extend radially from the rotatable head for a distance of 2-300, or 2-250, or 4-200, or 5-175, or 10-150, or 15-100, or 4-50, or 6-40, or 8-30, or 10-20, or 2-25, or 4-22, or 6-20, 8-18, or 10-16, millimeter. The shape of the elastomeric members can for example be selected from cylinder, truncated cylinder, right cone, oblique cone, truncated cube, truncated pyramid, truncated wedge, truncated parallelepiped, truncated prism, truncated antiprism, truncated cupola and truncated frustum, the term "truncated" refers to a geometric solid of the named type having an apex, vertex or end cut off by a plane.

The frictional contact between the exterior coating and the elastomeric members can supply part or all of the heating of the Releasable SCC polymer coating.

5 In some embodiments, at least part of the physical disturbance of the coating(s) is provided by one or more of an abrasive pad, a brush, or an impactor (the term "impactor" being used to denote a device which will impart impact to the coating(s) and help to break the coating(s) into multiple pieces that can be separated from the substrate. Preferably the impactor imparts both impact and shear to the coating(s). The impactor can also deliver heat to the coating(s).

10 In some embodiments, at least the exterior coating is scored before the heating takes place, and/or simultaneously with the heating, and/or after the heating. The scoring can be carried out using any scoring device, having pointed, blunt or rounded members which contact the coating(s), for example one or more of abrasive scrubbing pads, screens, brushes, discs, metallic combs, hard plastic
15 combs, pins, needles and scrapers. The scoring preferably does not damage the substrate

When at least some of the heating takes place before physical disturbance of the coating(s), the physical disturbance preferably takes place immediately after the heating.

20 The discrete parts resulting from the physical disturbance can be collected in any way, for example by means of a vacuum device which is optionally part of a device which provides the physical disturbance of the coating(s). The vacuum device can optionally also remove water.

In some embodiments of the process of removing the heat-releasable
25 coating, the coating is heated by contact with a hot metal surface which is at a temperature above the release temperature of the coating. In some embodiments of the process, the coating is heated by contacting the coating with steam which is at a temperature above the release temperature of the coating. In some embodiments of the process, the coating is heated by
30 coating with hot water which is at a temperature above the release temperature of the coating. In some embodiments of the process, the coating is heated by

contacting the coating with hot air which is at a temperature above the release temperature of the coating.

In some embodiments, the temperature-releasable coating is a cool-release coating comprising (i) a cool-release polymer having freezing
5 temperature T_f of less than 15°C and a peak melt temperature T_p of greater than 25°C , and (ii) a film-forming polymer comprising at least one member selected from the group consisting of polyurethane, acrylic polymer, polysiloxane, polysilazane, polyester, polyamide, polyurea, epoxy polymer, vinyl polymer, polyether, polyaldehyde, polyketone, and polycarbonate.

10 In some embodiments, the temperature-releasable coating is a multilayer coating comprising (i) a cool-release layer comprising a cool-release polymer having a freezing temperature T_f of less than 15°C and a peak melt temperature T_p of greater than 25°C , and (ii) the wear layer comprising a film-forming polymer comprising at least one member selected from the group consisting of
15 polyurethane, acrylic polymer, polysiloxane, polysilazane, polyester, polyamide, polyurea, epoxy polymer, vinyl polymer, polyether, polyaldehyde, polyketone, and polycarbonate. The cool-release layer is between the flooring substrate and the wear layer.

In some embodiments, the temperature-releasable coating comprises a
20 cool-releasable wear layer over the flooring substrate. The cool-releasable wear layer comprises both (i) a cool-release polymer having a freezing temperature T_f of less than 15°C and a peak melt temperature T_p of greater than 25°C , and (ii) a film-forming polymer comprising at least one member selected from the group consisting of polyurethane, acrylic polymer, polysiloxane, polysilazane, polyester,
25 polyamide, polyurea, epoxy polymer, vinyl polymer, polyether, polyaldehyde, polyketone, and polycarbonate.

In some embodiments, the temperature-releasable coating comprises a cool-releasable coating over the flooring substrate. The coating comprises (i) a polymeric adhesion composition which is substantially non-tacky at or below
30 about 7.2°C and which is tacky at 18°C , wherein the adhesive composition

comprises a cool-release polymer having a heat of fusion of at least 20 Joules/g and an onset of melt temperature T_0 of from about 2°C to 18°C, and (ii) a film-forming polymer comprising at least one member selected from the group consisting of polyurethane, acrylic polymer, polysiloxane, polysilazane, polyester, polyamide, polyurea, epoxy polymer, vinyl polymer, polyether, polyaldehyde, polyketone, and polycarbonate.

In some embodiments, the coating is a cool-release coating and the coating removal process comprises contacting the coating with a cool metal surface which is at a temperature below the release temperature of the coating.

10 In some embodiments, the coating is a cool-release coating and the coating removal process comprises contacting the coating with cool water which is at a temperature below the release temperature of the coating. In some

embodiments, the coating is a cool-release coating and the coating removal process comprises contacting the coating with cool air which is at a temperature

15 below the release temperature of the coating.

In some embodiments of the process, the disintegration and loosening of the temperature-releasable coating is carried out by impacting the coating with a stream of water emitted from a nozzle while the water is under relatively high pressure, i.e., with the water is emitted from the nozzle at a pressure of from 500

20 to 30,000 psi, such as from a pressure washer. In some embodiments, the water is emitted from the nozzle at a pressure of from 1000 psi to 20,000 psi, or from 1200 psi to 15,000 psi, or from 1500 psi to 10,000 psi, or from 1500 psi to 8000 psi, or from 2000 psi to 6000 psi. The application of a stream of high pressure water to disintegrate and loosen the temperature-releasable coating can be

25 carried out on a scored coating, or on an unscored coating.

In some embodiments of the process, the stream of water emitted from the nozzle travels from 0.5 cm to 75 cm before impacting the coating. In other embodiments, the stream of water emitted from the nozzle travels from 1 cm to 50 cm before impacting the coating, or from 2 cm to 25 cm, or from 3 cm to 20

30 cm, or from 4 cm to 15 cm.

In some embodiments of the process in which the stream of water is applied to a heat-release coating, the water is provided to the nozzle at a temperature of from 27 to 120°C. In other embodiments, water is provided to the nozzle at a temperature of from 30°C to 105°C, or of from 40°C to 100°C, or of
5 from 45°C to 95°C, or of from 50°C to 90°C, or of from 55°C to 85°C, or of from 60°C to 80°C.

In some embodiments of the process in which the stream of water is applied to a cool-release coating, the water is provided to the nozzle at a temperature of from -25°C to 15°C, or from -20°C to 15°C, or of from -10°C to
10 10°C, or of from -5°C to 10°C, or of from 0°C to 10°C. Water can be supplied below 0°C by the addition of a solute, such as sodium chloride, thereby depressing the freezing point of the water.

In some embodiments of the process, water is emitted from the nozzle at a rate of from 2 liters/min to 45 liters/min. In other embodiments, water is emitted
15 from the nozzle at a rate of from 3.7 liters/min to 37 liters/min, or from 5 liters/min to 30 liters/min, or from 7 liters/min to 25 liters/min, or from 8 liters/min to 20 liters/min, or from 9 liters/min to 18 liters/min, or from 10 liters/min to 15 liters/min.

In some embodiments of the process, the disintegration and loosening of
20 the temperature-releasable coating is carried out by contacting the coating with a plurality of elastomeric protrusions.

In some embodiments of the process, a heat-releasable coating is first heated to its release temperature by means other than contact with a plurality of elastomeric protrusions, i.e., by one or more of the other means disclosed herein,
25 with the heated coating thereafter being disintegrated and loosened by contact with (i.e., impact and/or rubbing) the plurality of elastomeric protrusions. In other embodiments of the process, contacting the coating with a plurality of elastomeric protrusions can both (i) heat a heat-releasable coating to its release temperature as well as (ii) disintegrate and loosen the heat-releasable coating.

In some embodiments of the process, the plurality of elastomeric protrusions extend radially from a rotatable member, and are rotated into contact with the coating.

5 In some embodiments, the elastomeric protrusions contact the coating while at a tip speed of from 20 to 1000 meters per minute. In some embodiments, the tip speed can be from 40 to 700 m/min, or from 50 to 500 m/min, or from 60 to 400 m/min, or from 70 to 300 m/min.

10 In some embodiments, the disintegrating and loosening of the coating is carried out by applying to the coating at least one member selected from the group consisting of abrasive pad, brush, and impactor. As used herein, the term “impactor” refers to a device capable of imparting impact to the coating so as to cause one or more coating layers to (i) disintegrate (i.e., break into multiple pieces) and (ii) separate from the substrate. The most effective impactors impart both impact and shear in order to cause the coating to disintegrate and loosen
15 from the substrate. The impactor may be designed to generate heat to heat the coating to its release temperature, if it is a heat-release coating.

In the removal of a heat-releasable coating, it has been discovered that the abrasive step is preferably close to the heat source so as to allow the film to be abraded off the surface before the floor has a chance to cool below the trigger
20 temperature. In some embodiments, the heating of the coating can be followed immediately by an abrasive pad or brush to thoroughly remove the finish from the floor.

In some embodiments, the temperature change in combination with the disintegrating and loosening of the coating is followed up with separating the disintegrated, loose coating particles from the substrate. In some embodiments,
25 the process further comprises collecting the disintegrated, loosened, separated coating particles after they have been separated from the substrate. A head or nozzle, or other suitable means connected to a source of vacuum, may be provided to collect the disintegrated, loosened coating particles and/or fluids

(e.g., water). The vacuum source can be used to deposit the separated coating particles in a collection space or into a collection stream.

In any of the aspects of the coating removal process described above, the process can be carried out with or without scoring the coating. Scoring of the coating can assist in removal of the coating. Scoring of the coating disrupts the continuity of the coating, i.e., can be utilized to assist in disintegration and loosening of the coating. The mechanism for scoring the topcoats of the finish are numerous, and include abrasive scrubbing pads, screens, brushes, and discs, as well as metallic or hard plastic combs, pins, needles, scrapers, and the like. In an embodiment, the scoring is carried out so that the scoring device(s) score the coating without causing damage to the flooring substrate.

In embodiments of the process in which scoring is use, the scoring can be carried out before the coating is at the release temperature, while heating or cooling is being carried out but before the coating reaches the release temperature, and/or while or after heating or cooling have been carried out and the coating is at the release temperature. Scoring can be carried out by applying to the temperature-releasable coating at least one member selected from the group consisting of abrasive pad, screen, brush, abrasive disc, comb, pin, needle, scraper, etc. The scoring devices can be provided with pointed, blunt, or rounded edges to avoid flooring damage. They can also be made of a wide variety of materials.

The scoring of the temperature-releasable coating can be carried out without scoring the substrate. In lab floor testing of processes for removal of a heat-releasable coating, the action of scoring the topcoats immediately after heating, followed by the application of an abrasive stripping pad to the scored coating, resulted in improved finish removal versus carrying out the removal process in the same manner, except without scoring the coating.

In a floor stripping machine according to the sixth aspect, the means for heating or cooling the temperature-releasable floor coating can be a means for heating comprising at least one member selected from the group consisting of

convective circulatory heater, frictional heater, radiative heater, and conductive heater. If the means for heating is a convective circulatory heater, it may comprise at least one member selected from the group consisting of water heater, steam heater, and air heater, among other convective circulatory heaters
5 known to those of skill in the art.

In an embodiment of the floor stripping machine, the means for heating comprises a radiative heater comprising at least one member selected from the group consisting of infrared heater and microwave heater. Radiative heat can be provided from infrared lamps, hot plates, hot pads, hot rollers, hot air, etc.
10 Induction, ultraviolet, microwave, and ultrasonic heating are also possible options. The temperature-release coating can be provided with additives known to be receptors for various types of radiative heating.

In an embodiment of the floor stripping machine, the means for heating comprises a conductive heater comprising at least one member selected from
15 the group consisting of hot pad and hot plate.

In the floor stripping machine, if the means for heating is a frictional heater, it may comprise a rotatable impact member comprising a plurality of elastomeric impact protrusions extending from a rotatable core. In an embodiment, the elastomeric protrusions may have a ratio of length to average
20 cross-sectional area of from 0.5: 1 to 20:1. In an embodiment, the elastomeric protrusions may have a ratio of length to average cross-sectional area of from 1:1 to 15:1, or from 2:1 to 12:1, or from 3:1 to 10:1, or from 4:1 to 10:1, or from 5:1 to 10:1.

In an embodiment of the floor stripping machine, the elastomeric
25 protrusions extending from the core have a Shore A hardness of from 20 to 100. In an embodiment, the elastomeric protrusions extending from the core have a Shore A hardness of from 35 to 90, or a Shore A hardness of from 50 to 90, or a Shore A hardness of from 60 to 90, or a Shore A hardness of from 70 to 90, or a Shore A hardness of from 80 to 90.

In an embodiment of the floor stripping machine, the elastomeric protrusions may extend radially from the core for a distance of from 2 mm to 300 mm. In an embodiment, the elastomeric protrusions may extend radially from the core for a distance of from 2 mm to 250 mm, or from 4 mm to 200 mm, or from 5 mm to 175 mm, or from 10 mm to 150 mm, or from 15 mm to 100 mm. In an embodiment, the elastomeric protrusions may extend radially from the core for a distance of from 4 mm to 50 mm, or from 6 mm to 40 mm, or from 8 mm to 30 mm, or from 10 mm to 20 mm. In an embodiment, the elastomeric protrusions may extend radially from the core for a distance of from 2 mm to 25 mm, 4 mm to 22 mm, or from 6 mm to 20 mm, or from 8 mm to 18 mm, or from 10 mm to 16 mm. In an embodiment, the elastomeric protrusions may extend radially from the core for a distance of from 2 mm to 250 mm, or from 4 mm to 200 mm, or from 5 mm to 250 mm, or from 75 mm to 250 mm, or from 100 mm to 200 mm.

In an embodiment of the floor stripping machine, the elastomeric protrusions extend from the core with a shape comprising at least one member selected from cylinder, cone (including right cone and/or oblique cone), cube, pyramid, wedge, parallelepiped, prism, antiprism, cupola, and frustrum.

In an embodiment of the floor stripping machine, the elastomeric protrusions extend from the core with a shape comprising at least one member selected from truncated cylinder, truncated cone (right and/or oblique), truncated cube, truncated pyramid, truncated wedge, truncated parallelepiped, truncated prism, truncated antiprism, truncated cupola, and truncated frustrum. As used herein, the term "truncated" refers to a geometric solid of the named type having an apex, vertex, or end cut off by a plane.

In an embodiment of the floor stripping machine, the rotatable impact member comprising the plurality of elastomeric impact protrusions may serve as both the heating means as well as the solid contact agitator for disintegrating the floor coating and loosening the temperature-releasable floor coating while the floor coating is at the release temperature.

In an embodiment of the floor stripping machine, the elastomeric protrusions are of a cylindrical or substantially cylindrical shape, with at least one of the elastomeric protrusions having a plurality of transverse ribs extending therefrom. In an embodiment, the protrusions have a length of from 10 cm to 15 cm and a diameter of from 1 cm to 3 cm.

In an embodiment, the solid contact agitator of the floor stripping machine comprises at least one member selected from the group consisting of brush, abrasive article, screen, comb, pin, scraper, and core having a plurality of elastomeric protrusions extending therefrom. In an embodiment, the solid contact agitator comprises an abrasive article comprising an abrasive pad, which can be present on a head attached to a driver.

In an embodiment for use when a cool-releasable SCC polymer composition is used, the floor stripping machine comprises a means for cooling comprising at least one member selected from the group consisting of a convective circulatory cooler and a conductive cooler. In an embodiment, the convective circulatory cooler comprises at least one member selected from liquid water at temperature of from -25°C to 15°C , and gaseous air at a temperature of from -50°C to 15°C . In an embodiment, the liquid water has a temperature of from -20°C to 15°C , or from -15°C to 12°C , or from -10°C to 10°C , or from -5°C to 10°C , or from 0°C to 10°C , or from 1°C to 10°C , or from 2°C to 10°C , or from 2°C to 8°C , or from -2°C to 5°C . In an embodiment, the gaseous air has a temperature of from -40°C to 14°C , or from -30°C to 13°C , or from -20°C to 12°C , or from -10°C to 10°C , or from -5°C to 10°C , or from -5°C to 5°C . In an embodiment, the conductive cooler comprises at least one member selected from ice and solid carbon dioxide. In an embodiment, the conductive cooler further comprises at least one member selected from a conductive plate and a conductive pad.

In an embodiment, the floor stripping machine further comprises a means for scoring the temperature-releasable floor coating. In an embodiment, the scoring means scores the temperature-releasable floor coating before the

coating is at the release temperature. In an embodiment, the scoring means scores the temperature-releasable floor coating while the coating is at the release temperature. In an embodiment, the scoring means scores the temperature-releasable floor coating while the heating or cooling is being carried out, but before the coating reaches the release temperature.

In an embodiment, the means for scoring comprises at least one member selected from the group consisting of an abrasive pad, a screen, a brush, an abrasive disc, a comb, a pin, a needle, and a scraper. In an embodiment, the scoring means comprises at least one abrasive pad mounted on a head, which head is powered by a driver. The head can be powered for linear motion, circular motion, combination of linear and circular motion, random motion, etc.

In an embodiment of the floor stripping machine, the machine comprises a steam generator, or the machine is supplied with steam from a separate steam source. In an embodiment, the machine comprises a steam manifold. In an embodiment, the steam manifold has scoring means affixed thereto or integral therewith.

In an embodiment, the means for scoring is a means for scoring the temperature-releasable floor coating without scoring the substrate.

In an embodiment, the solid contact agitator comprises a rotatable scrubbing head comprising rotatable brush or pad, and at least one rotatable heating or cooling manifold either surrounding the rotatable scrubbing head, or surrounded by the rotatable scrubbing head, with the manifold having scoring elements affixed thereto for scoring the temperature-releasable floor coating during rotation of the manifold over the flooring substrate. In an embodiment, the at least one manifold is a steam manifold and the machine further comprises means for generating steam in the at least one steam manifold or supplying steam to the at least one steam manifold. In an embodiment, the steam manifold comprises one or more steam outlets for distributing steam in close proximity to the rotatable brush or pad.

The steam inlet can also be directly in the center of a standard single-disc swing machine. This method relies upon the abrasiveness of the pad on the machine to score, abrade, and remove the film. Alternatively, the steam manifolds can be placed directly in front of the pad drivers of an autoscubber, as illustrated in FIG 6, described below. An insulating shroud can be provided to maintain the floor at an elevated temperature sufficient to bring a heat-release coating to its release temperature.

In an embodiment, the floor stripping machine further comprises means for collecting disintegrated coating particles that are loose on the surface of the flooring substrate. In an embodiment, the means for collecting the loose, disintegrated coating particles comprises a vacuum device. In an embodiment, the vacuum device is also suitable for vacuum removal of water from the flooring substrate.

Examples.

The invention is illustrated by the following Examples.

Example 1.

This example shows the preparation of SCC polymers suitable for use in this invention. Table 1 below sets out the monomers which were used to prepare Polymers 390-18, 390-28, 390-38, 390-44, 390-58, 390-78 and 390-100. Table 2 below sets out the properties of the prepared polymers.

Table 1.

Monomer Mixture A	Polym er 390- 18	Polym er 390- 28	Polym er 390- 38	Polym er 390- 44	Polym er 390- 58	Polym er 390- 78	Polyme r 390- 100
octadecyl acrylate	324	482	500	492	379	478	399

hexadecyl acrylate	216	58	34	34	162	68	171
methacrylic acid	16.9	17.0	17.0	14.2		14.1	
n-dodecyl Mercaptan		5.7	11.4	22.8	22.8	2.3	
butyl mercaptopropionate	5.7						1.0
Totals, gr	562.6	562.7	562.4	563.0	563.8	562.4	571.0

The polymers shown in Table 1 were prepared by delayed feed free-radical initiated redox polymerization of monomer emulsions to produce variations in molecular weight, acid functionality and melt transition temperature. The monomers were melted and blended at 45-50°C with a mercaptan chain transfer agent. The resulting mixture was then emulsified into an aqueous surfactant mixture B containing:

- 285.2 g deionized water
- 63.0 g n-propanol
- 10 12.0 g ethoxylated C10-C12 alcohol sulfosuccinate disodium salt, 31%
- 5.7 g ethoxylated C16-C18 alcohol
- 4.1 g ethoxylated C12-C14 secondary alcohol
- 0.2 g t-butyl hydroperoxide, 70% in water

The resulting monomer emulsion, kept warm at 38-42°C in a jacketed glass feeding tank, was pumped to a stirred reactor at 63-65°C containing:

- 320.1 g deionized water
- 0.03 g hydroxyethyl EDTA, ferric complex
- 63.1 g n-propanol
- 13.5 g ethoxylated C10-C12 alcohol sulfosuccinate disodium salt, 31%
- 20 4.5 g sodium alpha C12-14 olefin sulfonate, 35%
- 0.6 g ethoxylated C12-C14 secondary alcohol
- 30.0 g styrene-acrylic seed polymer, 0.05-0.06 □

simultaneously with a delayed feed of activator solution:

- 0.45 g hydroxymethane sulfinic acid, sodium salt
- 25 24.7 g deionized water

4.8 g n-propanol

while maintaining reactor contents at 63-65°C for two hours until all feeds were completed.

The following initiator and activator solutions were pumped into the reactor over

5 80 minutes at 62-63°C in order to reduce un-reacted monomer levels:

Initiator:

0.38 g t-butyl hydroperoxide

1.08 g ethoxylated C12-C14 secondary alcohol

1.25 g water

10

Activator:

0.60 g hydroxymethane sulfinic acid, sodium salt

19.5 g water

After feeds were completed and contents cooled to 38°C, pH was adjusted to 7.3

15 with 25% aqueous ammonia. After cooling to room temperature, the product was filtered through 200 mesh screen yielding about 1.3 kg of emulsion.

Table 2

Finished Properties	Polym er 390- 18	Polym er 390- 28	Polym er 390- 38	Polym er 390- 44	Polym er 390- 58	Polym er 390- 78	Polyme r 390- 100
Net yield, gr	1280	1323	1343	1356	1364	1385	1348
Viscosity, cP	35	510	72	184	80	36	74
NV solids, %	45.6	42.9	43.4	43.6	43.4	43.2	44.3
pH	6.5	7.0	7.1	7.3	6.3	7.2	7.0
Median particle size, nm	950	126	110	122	105	129	158
Tp @10°C/min	39.72	45.62	45.76	45.29	42.75	45.88	44.55
To @10°C/min	34.74	42.24	42.88	42.23	39.85	42.49	42.16
Tp - To	5.02	3.38	2.88	3.06	2.90	3.30	2.39

Mw, daltons	22,547	30,96 5	19,78 9	7,738	7,049	87,34 6	179,25 1
Mn, daltons	4,067	6,866	2,998	3,783	3,598	12,43 7	3,890
Polydispersity	5.5	4.5	6.6	2.0	2.0	7.0	46.1

Example 2.

This example shows the conversion of SCC polymers 390-38 and 390-44 into SCC polymer compositions suitable for coating on a substrate, using a stepwise blending procedure to incorporate the less compatible ingredients with the polymer emulsions. In the first step, a polymer mixture was prepared from the ingredients shown in Table 3 below. In the second step, the resulting polymer mixture was blended with the diluent mixture shown in Table 4, to produce an SCC polymer composition having the physical properties show in Table 4.

10 Table 3.

Polymer mixture (in grams)	390-63A	390-63B	390-65A	390-65C	390-75A
SCC polymer 390-44 (43.6% NV)	3.70		3.94	3.70	3.28
SCC polymer 390-38 (43.4% NV)		3.71			
Deionized water	20.00	20.01	20.21	20.41	22.53
Matrix polymer:					
Raykote 1610 (50.0% NV, 7°C MFFT)	2.20	2.20			
Raytech 22053 (40.9% NV, 2°C)			2.39		

MFFT)					
Rayflex 610 (58.0% NV, 0°C MFFT)				1.90	1.87
Thickener:					
Acrysol TT-935	0.70	0.53		0.41	0.33
Acrysol TT-615			0.54		
Sub-totals	26.60	26.45	26.56	26.42	28.01

Table 4.

Diluent mixture (in grams)	390-63A	390-63B	390-65A	390-65C	390-75A
Fluroad FC-4432	0.20	0.20	0.21	0.16	0.17
Ethanol	2.00	2.00	2.01	2.00	
Glycol Ether DE	3.00	2.00	2.00	2.00	3.74
KP-140		0.18		0.14	0.14
Deionized Water	37.52	37.04	38.67	37.45	34.92
Tegofoamex 1488	0.01	0.01	0.03	0.01	0.01
Color, Neutralize:					
Deionized Water	29.74	31.37	29.19	31.02	27.79
Colorant RU	0.27	0.35	0.30	0.15	
0.4% Methylene Blue					4.79
14% Ammonia	0.71	0.55	0.61	0.45	0.43
subtotal	73.45	73.70	73.02	73.38	71.99
Totals	100.05	100.15	99.58	99.80	100.00
Physical Properties:					

Theoretical %Solids	3.31	3.42	3.28	3.25	2.98
SCC polymer/Carrier Ratio	59.4/40 .6	59.4/40 .6	59.4/40 .6	59.4/40 .6	56.9/43 .1
Viscosity, cP	17.5	14	15	14.5	11
pH	9.7	9.7	8.9	9.6	9.2

Example 3.

This example describes the preparation of test panels having a coating of a Releasable SCC Polymer Composition and three coats of Vectra floor finish, and, for comparison purposes, a similar test panel which did not have a coating of a Releasable SCC Polymer Composition.

The test panels were 6"x12" x 0.1" polished stainless steel panels. The panels were first sanded with 220 grit sandpaper, washed, rinsed and air dried before coating. Old Masters Gloss Polyurethane (31.9% NV solids) was tinted white with KXX universal paint colorant. This urethane base coat was applied to the steel panels using a #30 Mayer rod applicator in one coat and air dried for 48 hrs before application of the SCC polymer composition. The SCC polymer composition was hand wiped over the dried urethane base using a 2"x2" folded cheesecloth "gauze sponge" saturated with 4 grams of the SCC polymer composition of which about 1 gram actually transfers to the panel. After drying the coated panels for about 2 hours under ambient conditions to obtain a non-tacky surface, a coat of Vectra floor finish (a commercial styrene-acrylic coating from Diversey containing about 19% solids) was quickly spread over the panel with a new gauze sponge. After one hour drying for each coat, two additional single coats were wiped on the panel for a total of three coats. Two or three 1/2" x 4" strips of polyester sheer Organza fabric were laid in parallel on the third Vectra coat while it was still damp. 10-15 drops of additional liquid Vectra finish were applied to the top of each fabric strip in order to embed the fabric for peel tests. The test panels were allowed to dry for a minimum of 48 hours before peel testing.

For comparison purposes, another test panel was prepared in the same way, except that there was no coating of an SCC polymer-containing composition Example 4.

This example describes testing of the coated substrates prepared in Example 3.

In the first part of this example, the stainless steel panels were secured to the movable platen of an IMass Slip-Peel tester (Model 101-B or 102-C), being fitted with circulating heat transfer fluid to maintain a surface temperature of 22°C in some experiments and 50°C in other experiments. After at least 10 minutes for the panel surface to reach the desired surface temperature, a razor blade was used to lightly score the coating around the four edges of each fabric strip to isolate it from the rest of the panel. The 1 kg load cell of the tester, after a static 500 gr calibration adjustment, was returned to a horizontal test position over the platen. The instrument was set to record at ½ scale (500 gram setting) and operated at a speed of 12"/min where each peel test was averaged over 10 seconds. To initiate a test, one end of the strip was manually peeled back about ¼", taped to the end of the test arm and the initial slack taken up at the beginning of travel before averaging started. For each sample, three strips each were tested at 22°C and 50°C. After accounting for the ½" strip width and half scale averaging, the peel strength was recorded in grams per inch of width. Generally, in the panels having an Releasable SCC polymer coating, the coating failure occurred mostly at the release coating interface, with small spots of Vectra residue remaining at the 22°C test temperature but little or no Vectra residue on the surface when tested at 50°C. Table 5 below identifies the SCC polymer compositions used and provides details of the results of the testing.

Table 5.

Coating top coating removable strength (grab/inch in peel)

Stainless Test Panel	SCC Coating	22°C			50°C			50°C Avg	% Peel Reduced
		22°C #1	22°C #2	22°C #3	50°C #1	50°C #2	50°C #3		

Urethane base coat (32% solids, white)										
387-104-1	None	26 7	31 0	29 8	292	34 7	31 8	30 1	322	(0.1%)
387-112-2	390-65A	22 5	34 4	33 9	303	54	44	60	53	82.6%
387-112-3	390-63B	44 3	26 7	53 1	414	77	70	65	71	82.9%
387-112-4	390-63A	26 7	13 4	17 0	190	58	58	54	57	70.2%

Note.

Panel 387-104-1, which did not have an SCC coating, had a higher peel strength at 50°C than at 22°C.

Example 5.

5 This example describes the preparation of test panels in which the substrates were 12"x12"x1/8" vinyl floor tiles (VCT) which been scrubbed clean of mill finish with Diversey ProStrip at 4:1 dilution, followed by rinsing and drying. The tiles were cut in half, and the resulting 6"x12" tiles were coated with a base coat. For panels 387-113-2 and 387-113-3, the base coat was Old Masters Gloss
 10 Polyurethane applied in 2 coats by gauze sponge at 25% NV solids. For panels 387-112-1 and 387-113-1, the base coat was Old Masters Polyurethane tinted with 5% KXX universal paint color and applied in two coats by gauze sponge at 23.4% solids. For panel 387-114-1, the base coat was an 80/20 (solids basis) blend of Vectra with Sancure 825, a polyurethane dispersion supplied by Lubrizol
 15 Corporation and applied in 2 coats at 22% solids. For panels 387-113-4, 387-114-2 and 387-114-3, the base coat consisted of two coats of Vectra floor finish applied in 2 coats at 19 % solids. After drying for 48 hours, the Releasable SCC polymer coating was wiped on and dried for one hour to a non-tacky surface. This was followed by application of three coats of Vectra finish as described above for the
 20 stainless steel panels. In some, but not all, of the test samples, strips of polyester sheer organza fabric were applied to the upper coating of Vectra finish, as described for the stainless steel panels, to enable testing adhesive strength of the coatings by the 180° peel test described in Example 4.

Table 6.

Coating Top Coating Removal Strength (grams/inch in peel)

VCT Test Panel	SCC Coating	22°C #1	22°C #2	22°C #3	Avg @22°C	50°C #1	50°C #2	50°C #3	Avg @50°C	% Reduced 50°C v 22°C
No Base Coat										
390-146-2	390-65C	114	220	158	164	33	46	42	40	75.4%
390-146-3	390-63B	363	244	489	365	109	95	101	10 2	72.1%
Urethane Base Coat (25% solids, clear)										
390-146-1	none	867	1291	1267	1142	1324	833	593	91 7	19.7%
387-112-1	390-63A	435	564	196	398	93	78	90	87	78.2%
387-113-1	390-63A	343	197	314	285	28	38	40	35	87.6%
Urethane Base Coat (23% solids, white)										
387-113-2	390-65C	295	279	249	274	44	64	39	49	82.1%
387-113-3	390-63B	233	211	226	223	79	123	63	88	60.4%
Acrylic/Urethane Base coat (22% solids, clear)										
387-114-1	390-65C	251	309	274	278	30	43	36	36	86.9%
Styrene-Acrylic Base Coat (19% solids, clear)										
387-113-4	390-65C	217	176	180	191	40	40	34	38	80.1%
387-114-2	390-63B	216	387	222	275	90	91	93	91	66.8%
387-114-3	390-63A	178	185	170	178	112	95	85	97	45.2%

Note:

Panel 390-146-1, without an SCC coating, was unchanged from 22°C to 50°C.

5

Example 6.

This Example describes the response of coated VCT panels to coating removal with abrasive pads. The panels were manually rubbed with a piece of Taski Twister™ 800 grit Diamond floor scrubbing pad, first at 22°C and then at 50°C,. The test was conducted on test panels which had no fabric strip, and in “dry” mode with no fluids being used to aid in coating removal. Only the hand rubbing of the scrubbing pad was responsible for removal of the coating in the

10

form of small flakes or powder. Table 7 below shows the results of the manual abrasion testing of the VCT test panels, all of which were finished with 3 coats of Vectra.

Table 7

5

Test Panel	SCC Coating	Ease of Removal @ 22°C	Ease of Removal @ 50°C
No Base Coat			
390-128-1	None	4	4
390-146-2	390-65C	4	2
390-146-3	390-63B	4	2
Urethane Base Coat (32% solids, white)			
387-112-2	390-65A	3	1
387-112-3	390-63B	3	1-2
387-112-4	390-63A	4	1
Urethane Base Coat (25% solids, clear)			
387-112-1	390-63A	4	1-2
Urethane Base Coat (23% solids, white)			
390-146-1	None	4	4
387-113-1	390-63A	4	2
387-113-2	390-65C	4	1
387-113-3	390-63B	4	1
Styrene-Acrylic Base Coat (19% solids, clear)			
387-113-4	390-65C	3	1
387-114-1	390-65C	4	2
387-114-2	390-63B	4	2
387-114-3	390-63A	4	1

On a scale of 1 to 4:

1 indicates very little pressure was needed to remove the Vectra coatings,

2 indicates moderate pressure was needed to remove the Vectra coatings,
3 indicates high pressure was needed to remove the Vectra coatings,
4 indicates the Vectra coatings were not removed with high pressure.
When the ease of removal was 1, 1-2, or 2, the Vectra coating was
5 completely removed but only part of the SCC polymer coating was
removed. If the residue of the Releasable SCC polymer coating was given
a further coating of Vectra, the ease of removal of that further coating at
50°C was substantially the same.

10 **Figures 4-9.**

FIG. 4 illustrates a manually controlled, electrically-powered coating
removal machine 10 for removing a heat-releasable floor coating when supplied
with steam from an external source not illustrated. Coating removal machine 10
has annular rotary brush assembly 12 which rotates via power supplied from
15 electric motor 14. Coating removal machine 10 is provided with a pair of wheels
16 for ease of manual transport to a desired location for use. When brush 12 is
in contact with the floor, wheels 16 can be designed to be fully off the ground,
with the full weight of machine 10 bearing down on brush assembly 12. A
proximal end of manual control shaft 20 is connected to housing 18 via hinge 22,
20 with the distal end of control shaft 20 connected to manual control handle 24.
Manual control handle 24 contains hand placement members, and may optionally
contain a power switch, rotation direction switch, speed control, etc. Supply line
26 can include a power line for supplying electricity to motor 14 from an external
source. Additionally or alternatively, supply line 26 can provide steam to one or
25 more steam manifolds (see Fig 5) in brush assembly 12. Machine 10 can be
designed so that electric motor 14 is powered by batteries contained within
housing 18, which of course could be redesigned to hold adequate battery power
for machine 10.

FIG. 5 illustrates a bottom view of brush assembly 12, which includes
30 rotatable head (not illustrated) on which is mounted support plate 29 from which
stiff bristles 28 extend downwardly, a plurality of steam manifolds 30, steam

nozzles 32, and scoring clips 34. Optionally, but as illustrated, scoring clips 34 have the dual function of scoring the coating while also securing steam manifolds 30 in place relative to rotatable support plate 29. Although not revealed by the bottom view of FIG. 5, scoring clips are sized, shaped, and positioned to score the heat-releasable floor coating as brush assembly rotates via rotational power supplied through shaft 36 which is driven by motor 14 via belt, gears, chain, direct drive, etc. As the head rotates, the manifolds distribute steam over a wide area, scores the topcoat on the heated floor, and scrubs the remaining finish off the floor.

FIG. 6 illustrates an alternative manually-controlled, electrically-powered coating removal machine 40 for removing a heat-releasable floor coating. Coating removal machine 40 has lower housing 42 beneath which is a rotatable friction heater, not illustrated in FIG. 6. Lower housing 42 is hingedly connected to upper housing 43 which terminates in manual control handle 45. Although not illustrated in FIG. 6, an exemplary friction heater is illustrated in FIG 7, described below. Coating removal machine 40 operates by frictional contact with a heat-releasable floor coating, and accordingly may, but need not be, supplied with steam and/or any other source of heat. Coating removal machine 40 may optionally be provided with one or more scoring members, not illustrated. Such scoring members can advantageously be located on the rotatable friction heater, or can be located elsewhere on coating removal machine 40. Coating removal machine 40 is provided with a pair of wheels 44 for ease of manual transport to a desired location for use. Coating removal machine 40 can be battery powered or optionally may receive electrical power from an external source via electrical cord 46. Housing 42 can surround an electric motor for providing power to the rotatable friction heater.

FIG. 7 illustrates a perspective view of rotatable frictional heater element 50 having hollow tubular base 52 having a plurality of elastomeric protrusions 54 integral therewith (or mounted thereon) and extending radially outward therefrom. In FIG. 7, elastomeric protrusions in the form of truncated pyramids. Hollow tubular base 52 has internal surface 56 providing passageway 58 through

frictional heater element 50, with frictional heater element 50 being mountable on a rotatable support member (not illustrated) passing through passageway 58 and contacting internal surface 56. Use of rotatable frictional heater element 50 on a heat-releasable floor coating results in heating the coating via friction from impact with the plurality of protrusions, breaking up (i.e., disintegrating) the coating via impact of the plurality of protrusions on the heated coating, and loosening and separating the disintegrated, loosened pieces of the heated coating from the floor substrate via shear force provided by the directional, frictional engagement of the plurality of protrusions against the disintegrated, loosened pieces of the heated floor coating. Scoring is optional, but may enhance the efficiency of coating removal.

FIG. 8 is a perspective view of a second alternative manually-held, manually-controlled, electrically-powered coating removal machine 60 for removing a heat-releasable floor coating. Coating removal machine 60 comprises electric drill housing 62 surrounding an electric motor (not shown) with motor shaft engaging and providing rotational power to chuck 64 in which is mounted a rotatable impact member comprising shaft 66 extending through rotatable core 68 from which extend a plurality of elongated, flexible, ribbed, elastomeric, friction generating, cylindrical impact members 70 commonly referred to as “chicken pluckers” because they are used in automatic chicken plucking machines. Use of coating removal machine 60 on a heat-releasable floor coating results in heating the coating via friction from impact with the chicken pluckers, breaking up (i.e., disintegrating) the coating via impact of the chicken pluckers on the heated coating, and loosening and separating the disintegrated, loosened pieces of the heated coating from the floor substrate via shear force provided by the directional, frictional engagement of the chicken pluckers against the disintegrated, loosened pieces of the heated floor coating. Scoring is optional, but may enhance the efficiency of coating removal.

FIG. 9 illustrates a perspective view of an electrically-powered, walk-behind coating removal machine 80 for removing a heat-releasable floor coating. Walk-behind coating removal machine 80 has a plurality of wheels 82 which

optionally can be powered and/or steerable for ease of transport, movement and control over a floor surface. Housing 84 surrounds a motor (not illustrated) for providing rotational power to one or more rotational scrubbing pad assemblies and/or brush assemblies or comb assemblies or abrasive member assemblies covered by shroud 86. The brush, comb, and/or pad assemblies may optionally further comprise one or more scoring elements and/or one or more heating elements such as the steam manifolds and nozzles as illustrated and described above. Walk-behind coating removal machine 80 may be electrically powered by one or more batteries, or may utilize supply cord 88 for electricity and/or steam or other hot gas or fluid. Coating removal machine 80 may be provided with steam from a source not illustrated or may use electrical power to generate steam with a boiler inside housing 84. Optionally, steam or other hot gas or fluid can be provided to hot pad 90 via conduit 92, in order to heat the coating to its release temperature, or assist in heating the coating to its release temperature, immediately before agitating the coating with the brush, comb, and/or abrasive pad assemblies which may optionally further include additional heating means and/or one or more scoring elements.

Some aspects of the invention are disclosed in the Statements below.

These Statements are not claims.

Statement 1: A process for removing a temperature-releasable coating from a substrate to which the coating is adhering, comprising:

A) heating or cooling the coating on the substrate until the temperature-releasable coating is at a release temperature;

B) disintegrating and loosening the coating while the coating is at the release temperature, to produce disintegrated coating particles that are loose on the substrate.

Statement 2: The process according to Statement 1, wherein the substrate comprises a flooring substrate.

Statement 3: The process according to any of Statements 1-2, further

comprising scoring the temperature-releasable coating to form a scored coating.

Statement 4: The process according to Statement 3, wherein the scoring is carried out before the coating is at the release temperature.

Statement 5: The process according to Statement 3, wherein the scoring is initiated while the heating or cooling is being carried out, but before the coating reaches the release temperature.

5 Statement 6: The process according to Statement 3, wherein the scoring is carried out while the coating is at the release temperature.

Statement 7: The process according to any of Statements 3-6, wherein the scoring is carried out by applying, to the temperature-releasable coating, at least one member selected from the group consisting of an abrasive pad, a screen, a brush, an abrasive disc, a comb, a pin, a needle, and a scraper.

10 Statement 8: The process according to any of Statements 3-7, wherein the scoring of the coating is carried out without scoring the substrate.

Statement 9: The process according to any of Statements 3-8, wherein the disintegration and loosening of the scored coating is carried out by impacting the scored coating with a stream of water emitted from the nozzle at a pressure of
15 from 500 to 30,000 psi.

Statement 10: The process according to Statement 9, wherein the stream of water emitted from the nozzle travels from 0.5 cm to 75 cm before impacting the scored coating.

20 Statement 11: The process according to any of Statements 9-10, wherein the coating is a heat-release coating and the water is provided to the nozzle is at a temperature of from 27°C to 120°C.

Statement 12: The process according to any of Statements 9-11, wherein the coating is a cool-release coating and the water is provided to the nozzle is at a temperature of from -25°C to 15°C.

25 Statement 13: The process according to any of Statements 9-12, wherein the stream of water is emitted from the nozzle at a rate of from 2 liter per minute to 45 liters per minute.

30 Statement 14: The process according to any of Statements 2-13, wherein the disintegration and loosening of the scored coating is carried out by contacting the scored coating with a plurality of elastomeric protrusions.

Statement 15: The process according to Statement 14, wherein the plurality of elastomeric protrusions extend radially from a rotatable member, and are rotated into contact with the scored coating.

5 Statement 16: The process according to any of Statements 14-15, wherein each of the elastomeric protrusions contact the scored coating while having a tip speed of from 20 to 1000 meters per minute.

Statement 17: The process according to any of Statements 12-14, wherein the coating is a heat-release coating and the impact of the elastomeric protrusions with the scored coating also heats the scored coating to the release temperature.

10 Statement 18: The process according to any of Statements 1-2, wherein the process is carried out without scoring the substrate.

Statement 19: The process according to Statement 18, wherein the disintegration and loosening of the coating is carried out by impacting the coating with a stream of water emitted from a nozzle at a pressure of from 500 psi to
15 30,000 psi.

Statement 20: The process according to Statement 19, wherein the stream of water emitted from the nozzle travels from 0.5 cm to 75 cm before impacting the coating.

20 Statement 21: The process according to any of Statements 19-20, wherein the coating is a heat-release coating and the water passes into the nozzle at a temperature of from 27°C to 120°C.

Statement 22: The process according to any of Statements 19-20, wherein the coating is a cool-release coating and the water passes into the nozzle at a temperature of from -25°C to 15°C.

25 Statement 23: The process according to any of Statements 19-22, wherein the stream of water is emitted from the nozzle at a rate of from 2 liters per minute to 45 liters per minute.

Statement 24: The process according to Statement 18, wherein the disintegration and loosening of the coating are carried out by contacting the
30 coating with a plurality of elastomeric protrusions.

Statement 25: The process according to Statement 24, wherein the plurality of elastomeric protrusions extend radially from a rotatable member, and are rotated into contact with the coating.

5 Statement 26: The process according to any of Statements 24-25, wherein each of the elastomeric protrusions contact the coating while having a tip speed of from 20 to 1000 meters per minute.

Statement 27: The process according to any of Statements 24-26, wherein the coating is a heat-release coating and the impact of the elastomeric protrusions with the coating also heats the coating to the release temperature.

10 Statement 28: The process according to any of Statements 1-11, 13-21, and 23-27, wherein the coating is a heat-release coating and the heating of the coating comprises contacting the coating with a hot metal surface, the hot metal surface being at a temperature above the release temperature of the coating.

15 Statement 29: The process according to any of Statements 1-10, 12-16, 18-20, and 22-26, wherein the coating is a cool-release coating and the cooling of the coating comprises contacting the coating with a cool metal surface, the cool metal surface being at a temperature below the release temperature of the coating.

20 Statement 30: The process according to any of Statements 1-11, 13-21, and 23-28, wherein the coating is a heat-release coating and the heating of the coating comprises contacting the coating with hot water, the hot water being at a temperature above the release temperature of the coating.

25 Statement 31: The process according to any of Statements 1-10, 12-16, 18-20, 22-26, and 29, wherein the coating is a cool-release coating and the cooling of the coating comprises contacting the coating with cold water, the cold water being at a temperature below the release temperature of the coating.

30 Statement 32: The process according to any of Statements 1-11, 13-21, 23-28, and 30, wherein the coating is a heat-release coating and the heating of the coating comprises exposing the coating to hot air, the hot air being at a temperature above the release temperature of the coating.

Statement 33: The process according to any of Statements 1-10, 11-16, 18-20, 22-26, 29, and 31, wherein the coating is a cool-release coating and the cooling

of the coating comprises exposing the coating to cool air, the cool air being at a temperature below the release temperature of the coating.

Statement 34: The process according to any of Statements 1-11, 13-21, 23-28, 30, and 32 wherein the coating is a heat-release coating and the heating of the coating comprises exposing the coating to steam, the steam being at a
5 temperature above the release temperature of the coating.

Statement 35: The process according to any of Statements 1-34, wherein the disintegrating and loosening of the coating is carried out by applying to the coating at least one member selected from the group consisting of abrasive pad,
10 brush, and impactor.

Statement 36: The process according to any of Statements 1-35, further comprising separating the disintegrated, loose coating particles from the substrate.

Statement 37: The process according to Statement 36, further comprising
15 collecting the coating particles that have been separated from the substrate.

Statement 38: The process according to Statement 37, wherein the collecting is carried out using vacuum to separate the coating particles from the substrate and to deposit the separated coating particles in a collection space.

Statement 39: The process according to any of Statements 1-11, 13-21, 23-28,
20 30, 32, and 35-38, wherein the temperature-releasable coating is a heat-releasable multilayer coating comprising:

(A) a heat-releasable layer comprising a heat-release polymer exhibiting an onset of melting temperature, T_0 , of at least 27°C; and

(B) a wear layer comprising a film-forming polymer comprising at least one
25 member selected from the group consisting of polyurethane, acrylic polymer, polysiloxane, polysilazane, polyester, polyamide, polyurea, epoxy polymer, vinyl polymer, polyether, polyaldehyde, polyketone, and polycarbonate; and

wherein the heat-releasable layer is between the flooring substrate and the wear
30 layer.

Statement 40: The process according to any of Statements 1-11, 13-21, 23-28, 30, 32, and 35-38, wherein the temperature-releasable coating comprises a heat-

releasable wear layer over the flooring substrate, the heat-releasable wear layer comprising:

(A) a heat-release polymer having an onset of melting temperature, T_0 , of at least 27°C; and

5 (B) a film-forming polymer comprising at least one member selected from the group consisting of polyurethane, acrylic polymer, polysiloxane, polysilazane, polyester, polyamide, polyurea, epoxy polymer, vinyl polymer, polyether, polyaldehyde, polyketone, and polycarbonate.

Statement 41: The process according to any of Statements 1-10, 12-16, 18-20, 10 22-26, 29, 31, 33, and 35-38, wherein the temperature-releasable coating has a cool-releasable coating thereon, the cool-releasable coating comprising:

(A) a cool-release polymer having freezing temperature T_f of less than 15°C and a peak melt temperature T_p of greater than 25°C; and

15 (B) a film-forming polymer comprising at least one member selected from the group consisting of polyurethane, acrylic polymer, polysiloxane, polysilazane, polyester, polyamide, polyurea, epoxy polymer, vinyl polymer, polyether, polyaldehyde, polyketone, and polycarbonate.

Statement 42: The process according to any of Statements 1-10, 12-16, 18-20, 20 22-26, 29, 31, 33, and 35-38, wherein the temperature-releasable coating is a cool-releasable multilayer coating thereon, the cool-releasable multilayer coating comprising:

(A) a cool-release layer comprising a cool-release polymer having a freezing temperature T_f of less than 15°C and a peak melt temperature T_p of greater than 25°C; and

25 (B) a wear layer comprising a film-forming polymer comprising at least one member selected from the group consisting of polyurethane, acrylic polymer, polysiloxane, polysilazane, polyester, polyamide, polyurea, epoxy polymer, vinyl polymer, polyether, polyaldehyde, polyketone, and polycarbonate; and

30 wherein the cool-releasable layer is between the flooring substrate and the wear layer.

Statement 43: The process according to any of Statements 1-10, 12-16, 18-20, 22-26, 29, 31, 33, and 35-38, wherein the temperature-releasable coating comprises a cool-releasable wear layer over the flooring substrate, the cool-releasable wear layer comprising:

- 5 (A) a cool-release polymer having a freezing temperature T_f of less than 15°C and a peak melt temperature T_p of greater than 25°C; and
- (B) a film-forming polymer comprising at least one member selected from the group consisting of polyurethane, acrylic polymer, polysiloxane, polysilazane, polyester, polyamide, polyurea, epoxy polymer, vinyl
- 10 polymer, polyether, polyaldehyde, polyketone, and polycarbonate.

Statement 44: The process according to any of Statements 1-10, 12-16, 18-20, 22-26, 29, 31, 33, and 35-38, wherein the temperature-releasable coating comprises a cool-releasable coating over the flooring substrate, the coating comprising:

- 15 (A) a polymeric adhesion composition which is substantially non-tacky at or below about 7.2°C and which is tacky at 18°C, wherein the adhesive composition comprises a cool-release polymer having a heat of fusion of at least 20 Joules/g and an onset of melt temperature T_o of from about 2°C to 18°C, and
- 20 (B) a film-forming polymer comprising at least one member selected from the group consisting of polyurethane, acrylic polymer, polysiloxane, polysilazane, polyester, polyamide, polyurea, epoxy polymer, vinyl polymer, polyether, polyaldehyde, polyketone, and polycarbonate.

Statement 45: A process for applying and removing a floor coating, comprising:

- 25 (A) applying a heat-release coating composition to a flooring substrate, the heat-release coating composition comprising a heat-release polymer having onset of melting temperature, T_o , of at least 27°C;
- (B) drying the heat-release coating composition to form a heat-releasable layer over the flooring substrate;
- 30 (C) applying a wear layer coating composition over the heat-releasable layer, the wear layer coating composition comprising a film-forming polymer comprising at least one member selected from the group

consisting of polyurethane, acrylic polymer, polysiloxane, polysilazane, polyester, polyamide, polyurea, epoxy polymer, vinyl polymer, polyether, polyaldehyde, polyketone, and polycarbonate;

5 (D) drying the wear layer coating composition to form a wear layer over the heat-releasable layer to produce a heat-releasable multilayer floor coating over the flooring substrate;

(E) trafficking the floor in a manner causing the floor to undergo a degradation of appearance;

10 (F) heating the heat-releasable multilayer coating over the substrate until the heat-releasable multilayer coating is at a release temperature; and

15 (G) disintegrating and loosening the heat-releasable multilayer coating while the heat-releasable multilayer coating is at the release temperature, to produce disintegrated coating particles that are loose on the substrate.

Statement 46: The process according to Statement 45, further comprising scoring the heat-releasable coating to form a scored coating.

20 Statement 47: The process according to any of Statements 45-46, wherein the disintegration and loosening of the heat-releasable multilayer coating is carried out by impacting the coating with a stream of water emitted from a nozzle at a pressure of from 500 psi to 30,000 psi.

25 Statement 48: The process according to any of Statements 45-47, wherein the disintegration and loosening of the heat-releasable multilayer coating is carried out by contacting the heat-releasable multilayer coating with a plurality of elastomeric protrusions.

Statement 49: The process according to any of Statements 45, 47, and 48, wherein the process is carried out without scoring the heat-releasable multilayer coating.

30 Statement 50: The process according to any of Statements 45-49, wherein the heating of the heat-releasable multilayer coating comprises contacting the coating with a hot metal surface, the hot metal surface being at a temperature above the release temperature of the heat-releasable multilayer coating.

Statement 51: The process according to any of Statements 45-50, wherein the heating of the heat-releasable multilayer coating comprises contacting the coating with hot water and/or steam, the hot water and/or steam being at a temperature above the release temperature of the heat-releasable multilayer coating.

Statement 52: A process for applying and removing a floor coating, comprising:

(A) applying a heat-release wear layer coating composition to a flooring substrate, the coating composition containing:

(i) a heat-release polymer having an onset of melting temperature, T_0 , of at least 27°C; and

(ii) a film-forming polymer comprising at least one member selected from the group consisting of polyurethane, acrylic polymer, polysiloxane, polysilazane, polyester, polyamide, polyurea, epoxy polymer, vinyl polymer, polyether, polyaldehyde, polyketone, and polycarbonate;

(B) drying the heat-release wear layer composition to form a heat-releasable wear layer over the flooring substrate;

(C) trafficking the floor in a manner causing the floor to undergo a degradation of appearance;

(D) heating the heat-releasable wear layer until the heat-releasable wear layer is at a release temperature; and

(E) disintegrating and loosening the heat-releasable wear layer while the heat-releasable wear layer is at the release temperature, to produce disintegrated coating particles that are loose on the substrate.

Statement 53: The process according to Statement 52, further comprising scoring the heat-releasable wear layer to form a scored coating.

Statement 54: The process according to any of Statements 52-53, wherein the disintegration and loosening of the coating is carried out by impacting the coating with a stream of water emitted from a nozzle at a pressure of from 500 psi to 30,000 psi.

Statement 55: The process according to any of Statements 52-54, wherein the disintegration and loosening of the coating is carried out by contacting the coating with a plurality of elastomeric protrusions.

Statement 56: The process according to any of Statements 52, 54, and 55,

5 wherein the process is carried out without scoring the heat-releasable wear layer.

Statement 57: The process according to any of Statements 52-56, wherein the heating of the heat-releasable wear layer comprises contacting the heat-releasable wear layer with a hot metal surface, the hot metal surface being at a temperature above the release temperature of the heat-releasable wear layer.

10 Statement 58: The process according to any of Statements 52-57, wherein the heating of the heat-releasable wear layer comprises heating the heat-releasable wear layer with hot water and/or steam, the hot water and/or steam being at a temperature above the release temperature of the heat-releasable wear layer.

Statement 59: A process for applying and removing a floor coating, comprising:

- 15 (A) applying a cool-release coating composition to a flooring substrate, the cool-release coating composition comprising a cool-release polymer having a freezing temperature T_f of less than 15°C and a peak melt temperature T_p of greater than 25°C; and;
- 20 (B) drying the cool-release coating composition to form a cool-releasable layer over the flooring substrate;
- (C) applying a wear layer coating composition over the cool-releasable layer, the wear layer coating composition comprising a film-forming polymer comprising at least one member selected
- 25 from the group consisting of polyurethane, acrylic polymer, polysiloxane, polysilazane, polyester, polyamide, polyurea, epoxy polymer, vinyl polymer, polyether, polyaldehyde, polyketone, and polycarbonate;
- (D) drying the wear layer coating composition to form a wear layer
- 30 over the cool-releasable layer and provide a cool-releasable multilayer floor coating over the flooring substrate;

(E) trafficking the floor in a manner causing the floor to undergo a degradation of appearance;

(F) cooling the coating until the temperature-releasable coating is at a release temperature; and

5 (G) disintegrating and loosening the coating while the coating is at the release temperature, to produce disintegrated coating particles that are loose on the substrate.

Statement 60: The process according to Statement 59, further comprising scoring the cool-releasable coating to form a scored coating.

10 Statement 61: The process according to any of Statements 59-60, wherein the disintegration and loosening of the coating comprises impacting the coating with a stream of water emitted from a nozzle at a pressure of from 500 psi to 30,000 psi, the water having a temperature of from -25°C to 15°C.

15 Statement 62: The process according to any of Statements 59-61, wherein the disintegration and loosening of the coating comprises contacting the scored coating with a plurality of elastomeric protrusions.

Statement 63: The process according to any of Statements 59-62, wherein the process is carried out without scoring the coating.

20 Statement 64: The process according to any of Statements 59-63, wherein the cooling of the coating comprises contacting the coating with a cool metal surface, the cool metal surface being at a temperature below the release temperature of the coating.

Statement 65: A process for applying and removing a floor coating, comprising:

25 (A) applying a cool-release wear layer composition to a flooring substrate, the cool-release wear layer composition comprising a cool-release polymer having a freezing temperature T_f of less than 15°C and a peak melt temperature T_p of greater than 25°C, and a film-forming polymer comprising at least one member selected from the group consisting of polyurethane, acrylic polymer, polysiloxane, polysilazane, polyester, polyamide, polyurea, epoxy polymer, vinyl
30 polymer, polyether, polyaldehyde, polyketone, and polycarbonate;

(B) drying the cool-release wear layer composition to form a cool-releasable wear layer over the flooring substrate;

(C) trafficking the floor in a manner causing the floor to undergo a degradation of appearance;

5 (D) cooling the cool-release wear layer until the temperature-releasable cool-release wear layer is at a release temperature; and

(E) disintegrating and loosening the cool-release wear layer while the cool-release wear layer is at the release temperature, to produce disintegrated coating particles that are loose on the substrate.

10 Statement 66: The process according to Statement 65, further comprising scoring the cool-release wear layer to form a scored coating.

Statement 67: The process according to any of Statements 65-66 wherein the disintegration and loosening of the cool-release wear layer comprises impacting the cool-release wear layer with a stream of water emitted from a nozzle at a
15 pressure of from 500 psi to 30,000 psi, the water having a temperature of from -25°C to 15°C.

Statement 68: The process according to any of Statements 65-67, wherein the disintegration and loosening of the cool-release wear layer comprises contacting the scored cool-release wear layer with a plurality of elastomeric protrusions.

20 Statement 69: The process according to any of Statements 65, 67, and 68, wherein the process is carried out without scoring the coating.

Statement 70: The process according to any of Statements 65-69, wherein the cooling of the cool-release wear layer comprises contacting the cool-release wear layer with a cool metal surface, the cool metal surface being at a

25 temperature below the release temperature of the cool-release wear layer.

Statement 71: A floor stripping machine for stripping a temperature-releasable floor coating from a flooring substrate, comprising:

(A) means for heating or cooling the temperature-releasable floor coating to a release temperature;

30 (B) a solid contact agitator for disintegrating the floor coating and loosening the temperature-releasable floor coating while the floor coating is at the release temperature.

Statement 72: The floor stripping machine according to Statement 71, wherein the means for heating or cooling the temperature-releasable floor coating is a means for heating comprising at least one member selected from the group consisting of convective circulatory heater, frictional heater, radiative heater, and
5 conductive heater.

Statement 73: The floor stripping machine according to Statement 72, wherein the means for heating is a convective circulatory heater comprises at least one member selected from the group consisting of water heater, steam heater, and air heater.

10 Statement 74: The floor stripping machine according to Statement 72, wherein the means for heating is a frictional heater comprising a rotatable impact member comprising a plurality of elastomeric impact protrusions extending from a rotatable core.

Statement 75: The floor stripping machine according to Statement 74, wherein
15 the elastomeric protrusions extending from the core have a ratio of length to average cross-sectional area of from 0.5: 1 to 20:1.

Statement 76: The floor stripping machine according to any of Statements 74-75, wherein the elastomeric protrusions extending from the core have a Shore A hardness of from 20 to 100.

20 Statement 77: The floor stripping machine according to any of Statements 74-76, wherein the elastomeric protrusions extend radially from the core for a distance of from 2 mm to 25 mm.

Statement 78: The floor stripping machine according to any of Statements 74-77, wherein the elastomeric protrusions extend from the core with a shape
25 comprising at least one member selected from cylinder, cone (right and/or oblique), cube, pyramid, wedge, parallelepiped, prism, antiprism, cupola, and frustrum.

Statement 79: The floor stripping machine according to any of Statements 74-77, wherein the elastomeric protrusions extend from the core with a shape
30 comprising at least one member selected from truncated cylinder, truncated cone (right and/or oblique), truncated cube, truncated pyramid, truncated wedge,

truncated parallelepiped, truncated prism, truncated antiprism, truncated cupola, and truncated frustrum.

Statement 80: The floor stripping machine according to any of Statements 74-79 wherein the means for heating comprising the rotatable impact member
5 comprising the plurality of elastomeric impact protrusions is also serves as the solid contact agitator for disintegrating the floor coating and loosening the temperature-releasable floor coating while the floor coating is at the release temperature.

Statement 81: The floor stripping machine according to any of Statements 74-
10 80, wherein the elastomeric protrusions are of a cylindrical or substantially cylindrical shape, and wherein at least one of the elastomeric protrusions has a plurality of transverse ribs extending therefrom.

Statement 82: The floor stripping machine according to Statement 71, wherein the means for heating comprises the radiative heater, and the radiative heater
15 comprises at least one member selected from the group consisting of infrared heater and microwave heater.

Statement 83: The floor stripping machine according to Statement 71, wherein the means for heating or cooling comprises a means for heating, and the means for heating comprises the conductive heater, and the conductive heater
20 comprises at least one member selected from the group consisting of hot pad and hot plate.

Statement 84: The floor stripping machine according to any of Statements 71-83, wherein the solid contact agitator comprises at least one member selected from the group consisting of brush, abrasive article, screen, comb, pin, scraper,
25 and core having elastomeric impact protrusions.

Statement 85: The floor stripping machine according to Statement 84, wherein the solid contact agitator comprises an abrasive pad.

Statement 86: The floor stripping machine according to Statement 71, wherein the means for heating or cooling the temperature-releasable floor coating is a
30 means for cooling comprising at least one member selected from the group consisting of a convective circulatory cooler and a conductive cooler.

Statement 87: The floor stripping machine according to Statement 86, wherein the convective circulatory cooler comprises at least one member selected from liquid water at temperature of from -25°C to 15°C to, and gaseous air at a temperature of from -50°C to 15°C.

5 Statement 88: The floor stripping machine according to Statement 86, wherein the conductive cooler comprises at least one member selected from ice and solid carbon dioxide.

Statement 89: The floor stripping machine according to any of Statements 86-88, wherein the conductive cooler further comprises at least one member
10 selected from a conductive plate and a conductive pad.

Statement 90: The floor stripping machine according to any of Statements 86-89, wherein the solid contact agitator comprises at least one member selected from the group consisting of brush, abrasive article, screen, comb, pin, scraper, and roller or shaft having elastomeric impact protrusions.

15 Statement 91: The floor stripping machine according to Statement 90, wherein the solid contact agitator comprises an abrasive pad.

Statement 92: The floor stripping machine according to any of Statements 71-91, further comprising a means for scoring the temperature-releasable floor coating.

20 Statement 93: The floor stripping machine according to Statement 92, wherein the means for scoring is a means for scoring the temperature-releasable floor coating before the coating is at the release temperature.

Statement 94: The floor stripping machine according to Statement 92, wherein the means for scoring is a means for scoring the temperature-releasable floor
25 coating while the coating is at the release temperature.

Statement 95: The floor stripping machine according to Statement 92, wherein the means for scoring is a means for scoring the temperature-releasable floor coating while the heating or cooling is being carried out, but before the coating reaches the release temperature.

30 Statement 96: The floor stripping machine according to any of Statements 92-95, wherein the means for scoring comprises at least one member selected from

the group consisting of an abrasive pad, a screen, a brush, an abrasive disc, a comb, a pin, a needle, and a scraper.

Statement 97: The floor stripping machine according to Statement 93, wherein the means for heating comprises a steam manifold.

5 Statement 98: The floor stripping machine according to any of Statements 92-97, wherein the means for scoring is a means for scoring the temperature-releasable floor coating without scoring the substrate.

Statement 99: The floor stripping machine according to any of Statements 71-98, further comprising a rotatable scrubbing head comprising rotatable brush or
10 pad, and at least one rotatable heating or cooling manifold either surrounding the rotatable scrubbing head or surrounded by the rotatable scrubbing head, with the manifold having scoring elements affixed thereto for scoring the temperature-releasable floor coating during rotation of the manifold over the flooring substrate.

Statement 100: The floor stripping machine according to Statement 99, wherein
15 the at least one manifold is a steam manifold and the machine comprises means for generating steam in the at least one steam manifold or supplying steam to the at least one steam manifold.

Statement 101: The floor stripping machine according to Statement 99, wherein
20 the steam manifold comprises one or more steam outlets for distributing steam in close proximity to the rotatable brush or pad.

Statement 102: The floor stripping machine according to any one of Statements 71-101, further comprising means for vacuuming water and disintegrated coating particles that are loose on the surface of the flooring substrate.

Claim 1: A coated floor comprising:

(A) a flooring substrate;

(B) a heat-releasable multilayer coating system on the flooring

5

substrate, the heat-releasable multilayer coating comprising:

(i) a heat-releasable layer comprising a side-chain crystalline

polymer having a polymer backbone and crystalline side chains

attached to the polymer backbone, wherein the side-chain

crystalline polymer exhibits an onset of melting temperature,

10

T_0 , of at least 10°C; and

(ii) a wear layer comprising a film-forming polymer comprising at

least one member selected from the group consisting of

polyurethane, acrylic polymer, polysiloxane, polysilazane,

polyester, polyamide, polyurea, epoxy polymer, vinyl polymer,

15

polyether, polyaldehyde, polyketone, and polycarbonate; and

wherein the heat-releasable layer is between the flooring substrate

and the wear layer.

Claim 2: The coated floor according to claim 1, wherein the crystalline side chains make up at least 50 percent of the volume of the side-chain crystalline polymer.

20

Claim 3: The coated floor according to claim 1 or 2, wherein the crystalline side chains have a length greater than five times of a distance between the side chains.

Claim 4: The coated floor according to any of claims 1-3, wherein the side-chain crystalline polymer has a crystallinity resulting exclusively or predominantly from the crystalline side chains attached to the polymer backbone.

25

Claim 5: The coated floor according to any of claims 1-4, wherein the side-chain crystalline polymer comprises repeating units of the formula

30



where Y is an organic radical forming part of a polymer backbone and C_y comprises a crystallizable moiety present in an amount that the side-chain crystallizable polymer has a heat of fusion of at least 20 Joules/gram.

5 Claim 6: The coated floor according to any of claims 1-5, wherein the side-chain crystalline polymer exhibits an onset of melting temperature, T_o, of from 27°C to 100°C.

Claim 7: The coated floor according to any of claims 1-5, wherein the side-chain crystalline polymer exhibits a peak melting temperature, T_p, of from 30°C to 110°C.

10 Claim 8: The coated floor according to any of claims 1-7, wherein the side-chain crystalline polymer has a heat of fusion, as measured by a differential scanning calorimeter, of at least 20 Joules/gram and the side-chain crystalline polymer has an onset of melting temperature T_o of at least 27°C and a peak melting temperature T_p such that T_p – T_o is less than T_p^{0.7}.

15 Claim 9: The coated floor according to any of claims 1-8, wherein the side-chain crystalline polymer has a heat of fusion, as measured by a differential scanning calorimeter, of at least 20 Joules/gram and the side-chain crystalline polymer has an onset of melting temperature T_o of at least 27°C and a peak melting temperature T_p such that T_p – T_o is less than 25°C.

20 Claim 10: The coated floor according to any of claims 1-9, wherein the side-chain crystalline polymer comprises at least one member selected from the group consisting of acrylic polymer, vinyl polymer, polyester, polyimide, polyolefin, polystyrene, polyether, polyalkylene oxide, polyalkyl phosphazene, poly amino acid, polyisocyanate, polyurethane, polysilane, and polysiloxane.

25 Claim 11: The coated floor according to any of claims 1-10, further comprising a base layer between the flooring substrate and the heat-releasable layer.

Claim 12: The coated floor according to claim 11, wherein the base layer comprises at least one member selected from the group consisting of acrylic polymer, polyurethane, polyurea, epoxy polymer, polysiloxane, vinyl polymer,
30 and styrene-butadiene polymer.

Claim 13: The coated floor according to any of claims 1-12, wherein the heat-releasable multilayer coating comprises a plurality of heat-releasable layers and

a plurality of wear layers, with one of the heat-releasable layers being between each of the wear layers.

Claim 14: The coated floor according to any of claims 1-13, wherein the film-forming polymer does not comprise crystallizable side-chains.

- 5 Claim 15: The coated floor according to any of claims 1-14, wherein the heat-releasable layer comprises the side-chain crystalline polymer in an amount of at least 10 weight percent, based on layer weight.

Claim 16: The coated floor according to any of claims 1-15, wherein the film-forming polymer does not comprise crystalline side chains.

- 10 Claim 17: A multilayer floor coating system, comprising:

(A) a heat-release layer composition comprising a side-chain crystallizable polymer, wherein the side-chain crystallizable polymer has a polymer backbone and crystallizable side chains attached to the polymer backbone, and the side-chain crystallizable polymer exhibits an onset of melting temperature, T_0 , of at least 27°C; and

15

(B) an wear layer composition comprising a film-forming polymer, wherein the film-forming polymer comprises at least one member selected from the group consisting of polyurethane, acrylic polymer, polysiloxane, polysilazane, polyester, polyamide, polyurea, epoxy polymer, vinyl polymer, polyether, polyaldehyde, polyketone, and polycarbonate.

20

Claim 18: The multilayer floor coating system according to claim 17, wherein the crystallizable side chains make up at least 50 percent of the volume of the side-chain crystallizable polymer.

- 25 Claim 19: The multilayer floor coating system according to claim 17 or 18, wherein the crystallizable side chains have a length greater than five times of a distance between the side chains.

Claim 20: The multilayer floor coating system according to any of claims 17-19, wherein the side-chain crystallizable polymer has a crystallinity resulting

- 30 exclusively or predominantly from the crystallizable side chains attached to the polymer backbone.

Claim 21: The multilayer floor coating system according to any of claims 17-20, wherein the side-chain crystallizable polymer comprises repeating units of the formula



where Y is an organic radical forming part of a polymer backbone and C_y comprises a crystallizable moiety present in an amount that the side-chain crystallizable polymer has a heat of fusion of at least 20 Joules/gram.

Claim 22: The multilayer floor coating system according to any of claims 17-21, wherein the side-chain crystallizable polymer exhibits an onset of melting temperature, T_o , of from 27°C to 100°C.

Claim 23: The multilayer floor coating system according to any of claims 17-22, wherein the side-chain crystallizable polymer exhibits a peak melting temperature, T_p , of from 30°C to 110°C.

Claim 24: The multilayer floor coating system according to any of claims 17-23, wherein the side-chain crystallizable polymer has a heat of fusion, as measured by a differential scanning calorimeter, of at least 20 Joules/gram and the side-chain crystalline polymer has an onset of melting temperature T_o of at least 27°C and a peak melting temperature T_p such that $T_p - T_o$ is less than $T_p^{0.7}$.

Claim 25: The multilayer floor coating system according to any of claims 17-24, wherein the side-chain crystallizable polymer has a heat of fusion, as measured by a differential scanning calorimeter, of at least 20 Joules/gram and the side-chain crystallizable polymer has an onset of melting temperature T_o of at least 27°C and a peak melting temperature T_p such that $T_p - T_o$ is less than 25°C.

Claim 26: The multilayer floor coating system according to any of claims 17-25, wherein the side-chain crystallizable polymer comprises at least one member selected from the group consisting of acrylic polymer, vinyl polymer, polyester, polyimide, polyolefin, polystyrene, polyether, polyalkylene oxide, polyalkyl phosphazene, poly amino acid, polyisocyanate, polyurethane, polysilane, and polysiloxane.

Claim 27: The multilayer floor coating system according to any of claims 17-26, wherein the film-forming polymer does not comprise crystallizable side chains.

Claim 28: The floor coating system according to any of claims 17-27, wherein the film-forming polymer is not a pressure-sensitive adhesive.

5 Claim 29: The multilayer floor coating system according to any of claims 17-28, wherein the heat-release layer composition further comprises a first volatile carrier, and the wear layer composition further comprises a second volatile carrier.

10 Claim 30: The multilayer floor coating system according to claim 29, wherein the first volatile carrier comprises at least one member selected from the group consisting of water and organic solvent, and the second volatile carrier comprises at least one member selected from the group consisting of water and organic solvent.

15 Claim 31: The multilayer floor coating system according to claim 29 or 30, wherein the heat-release layer composition comprises the side-chain crystallizable polymer in an amount of at least 10 weight percent, based on composition weight.

Claim 32: The multilayer floor coating system according to any of claims 17-31, wherein the wear layer polymer does not comprise crystallizable side chains.

20 Claim 33: The multilayer floor coating system according to any of claims 29-32, wherein: (i) the side-chain crystallizable polymer is present as a first discontinuous phase in a first emulsion comprising the first volatile carrier, and (ii) the polymeric film forming agent is present as a second discontinuous phase in a second emulsion comprising the second volatile carrier.

25 Claim 34: The floor coating system according to claim 33, wherein the first emulsion is an aqueous emulsion and the second emulsion is an aqueous emulsion.

30 Claim 35: The multilayer floor coating system according to any of claims 17-34, further comprising a base layer composition comprising (i) at least one member selected from the group consisting of acrylic polymer, polyurethane, polyurea, epoxy polymer, polysiloxane, vinyl polymer, and styrene-butadiene polymer, and (ii) a third volatile carrier.

Claim 36: A coated floor comprising:

(A) a flooring substrate;

(B) a heat-releasable wear layer over the flooring substrate, the heat-releasable wear layer comprising:

5 (i) a side-chain crystalline polymer having a polymer backbone and crystalline side chains attached to the polymer backbone, wherein the crystalline polymer exhibits an onset of melting temperature, T_0 , of at least 27°C; and

10 (ii) a film-forming polymer comprising at least one member selected from the group consisting of polyurethane, acrylic polymer, polysiloxane, polysilazane, polyester, polyamide, polyurea, epoxy polymer, vinyl polymer, polyether, polyaldehyde, polyketone, and polycarbonate.

15 Claim 37: The coated floor according to claim 36, wherein the crystalline side chains make up at least 50 percent of the volume of the side-chain crystalline polymer.

Claim 38: The coated floor according to claim 36 or 37, wherein the crystalline side chains have a length greater than five times of a distance between the side chains.

20 Claim 39: The coated floor according to any of claims 36-38, wherein the side-chain crystalline polymer has a crystallinity resulting exclusively or predominantly from the crystalline side chains attached to the polymer backbone.

Claim 40: The coated floor according to any of claims 36-39, wherein the side-chain crystalline polymer comprises repeating units of the formula



30 where Y is an organic radical forming part of a polymer backbone and C_y comprises a crystallizable moiety present in an amount that the side-chain crystallizable polymer has a heat of fusion of at least 20 Joules/gram.

Claim 41: The coated floor according to any of claims 36-40, wherein the side-chain crystalline polymer exhibits an onset of melting temperature, T_o , of from 27°C to 100°C.

5 Claim 42: The coated floor according to any of claims 36-41 wherein the side-chain crystalline polymer exhibits a peak melting temperature, T_p , of from 30°C to 110°C.

10 Claim 43: The coated floor according to any of claims 36-42, wherein the side-chain crystalline polymer has a heat of fusion, as measured by a differential scanning calorimeter, of at least 20 Joules/gram and the side-chain crystalline polymer has an onset of melting temperature T_o of at least 10°C and a peak melting temperature T_p such that $T_p - T_o$ is less than $T_p^{0.7}$.

15 Claim 44: The coated floor according to any of claims 36-43, wherein the side-chain crystalline polymer has a heat of fusion, as measured by a differential scanning calorimeter, of at least 20 Joules/gram and the side-chain crystalline polymer has an onset of melting temperature T_o of at least 27°C and a peak melting temperature T_p such that $T_p - T_o$ is less than 25°C.

20 Claim 45: The coated floor according to any of claims 36-44, wherein the side-chain crystalline polymer comprises at least one member selected from the group consisting of acrylic polymer, vinyl polymer, polyester, polyimide, polyolefin, polystyrene, polyether, polyalkylene oxide, polyalkyl phosphazene, poly amino acid, polyisocyanate, polyurethane, polysilane, and polysiloxane.

Claim 46: The coated floor according to any of claims 36-45, further comprising a base layer between the flooring substrate and the heat-releasable wear layer.

25 Claim 47: The coated floor according to claim 46, wherein the base layer comprises at least one member selected from the group consisting of acrylic polymer, polyurethane, polyurea, epoxy polymer, polysiloxane, vinyl polymer, and styrene-butadiene polymer.

30 Claim 48: The coated floor according to any of claims 36-47, wherein the heat-releasable wear layer comprises the side-chain crystalline polymer in an amount of at least 10 weight percent, based on layer weight.

Claim 49: The coated floor according to any of claims 36-48, wherein the side-chain crystalline polymer is present as a plurality of blocks of a block copolymer,

and the film-forming polymer is also present as a plurality of blocks of the block copolymer.

Claim 50: The coated floor according to any of claims 36-49, wherein the film-forming polymer does not comprise crystalline side chains.

5 Claim 51: A floor coating system comprising a heat-release wear layer composition comprising:

(A) a side-chain crystallizable polymer having a polymer backbone and crystallizable side chains attached to the polymer backbone, wherein the side-chain crystallizable polymer exhibits an onset of
10 melting temperature, T_0 , of at least 27°C; and

(B) a film-forming polymer comprising at least one member selected from the group consisting of polyurethane, acrylic polymer, polysiloxane, polysilazane, polyester, polyamide, polyurea, epoxy polymer, vinyl polymer, polyether, polyaldehyde, polyketone, and
15 polycarbonate.

Claim 52: The floor coating system according to claim 51, wherein the heat-release wear layer composition further comprises a volatile carrier comprising at least one member selected from the group consisting of water and organic solvent.

20 Claim 53: The floor coating system according to claim 51 or 52, wherein the heat-release wear layer composition is an emulsion with the volatile carrier present as a continuous phase.

Claim 54: The floor coating system according to any of claims 51-53, wherein the side-chain crystallizable polymer is present in a first discontinuous phase and the
25 film-forming polymer is present in a second discontinuous phase.

Claim 55: The floor coating system according to any of claims 51-53, wherein the side-chain crystallizable polymer and the film-forming polymer are present in a single discontinuous phase.

Claim 56: The floor coating system according to any of claims 51-55, wherein
30 the heat-release wear layer composition is a first composition and the floor coating system further comprises a base layer composition comprising at least one member selected from the group consisting of acrylic polymer, polyurethane,

polyurea, epoxy polymer, polysiloxane, vinyl polymer, and styrene-butadiene polymer.

Claim 57: The floor coating system according to any of claims 51-56, wherein the heat-release wear layer composition contains a first volatile carrier

5 comprising at least one member selected from the group consisting of water and organic solvent, and a second volatile carrier comprising at least one member selected from the group consisting of water and organic solvent.

Claim 58: The floor coating system according to any of claims 51-57, wherein the crystallizable side chains make up at least 50 percent of the volume of the
10 side-chain crystallizable polymer.

Claim 59: The floor coating system according to any of claims 51-58 wherein the crystallizable side chains have a length greater than five times of a distance between the side chains.

Claim 60: The floor coating system according to any of claims 51-59, wherein
15 the side-chain crystallizable polymer has a crystallinity resulting exclusively or predominantly from the crystallizable side chains attached to the polymer backbone.

Claim 61: The floor coating system according to any of claims 51-60, wherein the side-chain crystallizable polymer comprises repeating units of the formula



where Y is an organic radical forming part of a polymer backbone and C_y

25 comprises a crystallizable moiety present in an amount that the side-chain crystallizable polymer has a heat of fusion of at least 20 Joules/gram.

Claim 62: The floor coating system according to any of claims 51-61, wherein the side-chain crystallizable polymer exhibits an onset of melting temperature, T₀, of from 27°C to 100°C.

30 Claim 63: The floor coating system according to any of claims 51-62, wherein the side-chain crystallizable polymer has a heat of fusion, as measured by a differential scanning calorimeter, of at least 20 Joules/gram and the side-chain

crystallizable polymer has an onset of melting temperature T_o of at least 27°C and a peak melting temperature T_p such that $T_p - T_o$ is less than $T_p^{0.7}$.

Claim 64: The floor coating system according to any of claims 51-62, wherein the side-chain crystallizable polymer has a heat of fusion, as measured by a differential scanning calorimeter, of at least 20 Joules/gram and the side-chain crystallizable polymer has an onset of melting temperature T_o of at least 27°C and a peak melting temperature T_p such that $T_p - T_o$ is less than 25°C.

Claim 65: The floor coating system according to any of claims 51-64, wherein the side-chain crystallizable polymer exhibits a peak melting temperature, T_p , of from 30°C to 110°C.

Claim 66: The floor coating system according to any of claims 51-65, wherein the side-chain crystallizable polymer comprises at least one member selected from the group consisting of acrylic polymer, vinyl polymer, polyester, polyimide, polyolefin, polystyrene, polyether, polyalkylene oxide, polyalkyl phosphazene, poly amino acid, polyisocyanate, polyurethane, polysilane, and polysiloxane.

Claim 67: The floor coating system according to any of claims 60-75, wherein the heat-release wear layer composition comprises the side-chain crystallizable polymer in an amount of at least 10 weight percent, based on a total weight of solids in the composition.

Claim 68: The floor coating system according to any of claims 51-67, wherein the film-forming polymer does not comprise crystallizable side chains.

Claim 69: The floor coating system according to any of claims 51-68, wherein the film-forming polymer is not a pressure-sensitive adhesive.

Claim 70: A coated floor comprising a flooring substrate and a cool-releasable coating thereon, wherein the cool-releasable coating comprises:

(A) a side-chain crystalline polymer having a polymer backbone and crystalline side chains attached to the polymer backbone, wherein the side-chain crystalline polymer has a freezing temperature T_f of less than 15°C and a peak melt temperature T_p of greater than 25°C; and

(B) a film-forming polymer comprising at least one member selected from the group consisting of polyurethane, acrylic polymer,

polysiloxane, polysilazane, polyester, polyamide, polyurea, epoxy polymer, vinyl polymer, polyether, polyaldehyde, polyketone, and polycarbonate.

- 5 Claim 71: The coated floor according to claim 70, wherein the freezing temperature T_f of the side-chain crystalline polymer is less than 13°C.
- Claim 72: The coated floor according to claim 71, wherein the freezing temperature T_f of the side-chain crystalline polymer is less than 10°C.
- Claim 73: The coated floor according to claim 70, wherein the freezing temperature T_f of the side-chain crystalline polymer is less than 7°C.
- 10 Claim 74: The coated floor according to any of claims 70-73, wherein the peak melt temperature T_p of the side-chain crystalline polymer is at least 30°C.
- Claim 75: The coated floor according to any of claims 70-73, wherein the peak melt temperature T_p of the side-chain crystalline polymer is at least 33°C.
- Claim 76: The coated floor according to any of claims 70-73, wherein the peak
15 melt temperature T_p of the side-chain crystalline polymer is at least 36°C.
- Claim 77: The coated floor according to any of claims 70-73, wherein the peak melt temperature T_p of the side-chain crystalline polymer is at least 39°C.
- Claim 78: The coated floor according to any of claims 70-77, wherein the side-chain crystalline polymer contains repeating units derived from at least one
20 member selected from the group consisting of acrylic acid, hydroxyethylacrylate, acrylamide, methacrylamide, methacrylic acid, linear or branched alkyl acrylates and methacrylates in which the alkyl group is crystalline, styrene, substituted styrene, and polyoxyalkylene.
- Claim 79: The coated floor according to claim 78, wherein the repeating units
25 comprise units derived from at least one n-alkyl acrylate or methacrylate in which the alkyl group contains from 14 to 22 carbon atoms.
- Claim 80: The coated floor according to claim 78 or 79, wherein the side-chain crystalline polymer contains from 1 wt % to 10 wt % of units derived from acrylic acid.
- 30 Claim 81: The coated floor according to any of claims 78-80, wherein the side-chain crystalline polymer comprises units derived from at least one polar

monomer selected from polyoxyalkylene, acrylate, acrylamide, and methacrylamide.

5 Claim 82: The coated floor according to any of claims 70-81, wherein the side-chain crystalline polymer contains units derived from at least two different monomers.

Claim 83: The coated floor according to any of claims 70-82, wherein the crystalline side chains make up at least 50 percent of the volume of the side-chain crystalline polymer.

10 Claim 84: The coated floor according to any of claims 70-83, wherein the crystalline side chains have a length greater than five times of a distance between the side chains.

Claim 85: The coated floor according to any of claims 70-84, wherein the side-chain crystalline polymer has a crystallinity resulting exclusively or predominantly from the crystalline side chains attached to the polymer backbone.

15 Claim 86: The coated floor according to any of claims 70-85, wherein the side-chain crystalline polymer comprises repeating units of the formula



20 where Y is an organic radical forming part of a polymer backbone and C_y comprises a crystallizable moiety present in an amount that the side-chain crystalline polymer has a heat of fusion of at least 20 Joules/gram.

Claim 87: The coated floor according to any of claims 70-85, wherein the film-forming polymer does not comprise crystalline side chains.

25 Claim 88: The coated floor according to any of claims 70-84, wherein the coating comprises a cool-releasable wear layer comprising both the side-chain crystalline polymer and the film-forming polymer.

Claim 89: The coated floor according to claim 88, further comprising a base layer between the flooring substrate and the cool-releasable wear layer.

30 Claim 90: The coated floor according to claim 89 wherein the base layer comprises at least one member selected from the group consisting of acrylic

polymer, polyurethane, polyurea, epoxy polymer, polysiloxane, vinyl polymer, and styrene-butadiene polymer.

5 Claim 91: The coated floor according to any of claims 70-87, wherein the side-chain crystalline polymer is present in a cool-releasable layer, and the film-forming polymer is present in a wear layer, and the cool-releasable layer is between the flooring substrate and the wear layer.

Claim 92: The coated floor according to claim 91, wherein the cool-releasable layer comprises the side-chain crystalline polymer in an amount of at least 10 weight percent, based on layer weight.

10 Claim 93: The coated floor according to claim 91 or 92, wherein the cool-releasable layer has a thickness of at least 0.001 inch.

Claim 94: The coated floor according to any of claims 91-93, further comprising a base layer between the flooring substrate and the cool-releasable layer.

15 Claim 95: The coated floor according to claim 94, wherein the base layer comprises at least one member selected from the group consisting of acrylic polymer, polyurethane, polyurea, epoxy polymer, polysiloxane, vinyl polymer, and styrene-butadiene polymer.

Claim 96: The coated floor according to any of claims 91-95, wherein the wear layer is free of side-chain crystalline polymer.

20 Claim 97: The coated floor according to any of claims 91-96, wherein the cool-releasable coating comprises a plurality of cool-releasable layers and a plurality of wear layers, with one of the cool-releasable layers being between each of the wear layers.

25 Claim 98: The coated floor according to any of claims 70-97, wherein the flooring substrate comprises vinyl composition tile, stone, concrete, plastic, linoleum, vinyl, vinyl composition tile, vinyl asbestos tile, marble, granite, terrazzo, travertine, slate, ceramic, glass, wood, metal, and rubber.

Claim 99: A floor coating system including a cool-release coating composition comprising:

30 (A) a side-chain crystallizable polymer, wherein the side-chain crystallizable polymer has a polymer backbone and crystallizable side chains attached to the polymer backbone, wherein the side-

chain crystallizable polymer has a freezing temperature T_f of less than 15°C and a peak melt temperature T_p of greater than 25°C; and

(B) a film-forming polymer, wherein the film-forming polymer comprises at least one member selected from the group consisting of polyurethane, acrylic polymer, polysiloxane, polysilazane, polyester, polyamide, polyurea, epoxy polymer, vinyl polymer, polyether, polyaldehyde, polyketone, and polycarbonate.

5

10

Claim 100: The floor coating system according to claim 99, wherein the freezing temperature T_f of the side-chain crystallizable polymer is less than 13°C.

Claim 101: The floor coating system according to claim 99, wherein the freezing temperature T_f of the side-chain crystallizable polymer is less than 10°C.

Claim 102: The floor coating system according to claim 99, wherein the freezing temperature T_f of the side-chain crystallizable polymer is less than 7°C.

15

Claim 103: The floor coating system according to any of claims 99-102, wherein the peak melt temperature T_p of the side-chain crystallizable polymer is at least 30°C.

20

Claim 104: The floor coating system according to any of claims 99-102, wherein the peak melt temperature T_p of the side-chain crystallizable polymer is at least 33°C.

Claim 105: The floor coating system according to any of claims 99-102, wherein the peak melt temperature T_p of the side-chain crystallizable polymer is at least 36°C.

25

Claim 106: The floor coating system according to any of claims 99-102, wherein the peak melt temperature T_p of the side-chain crystallizable polymer is at least 39°C.

30

Claim 107: The floor coating system according to any of claims 99-106, wherein the side-chain crystallizable polymer comprises repeating units derived from at least one member selected from the group consisting of acrylic acid, hydroxyethylacrylate, acrylamide, methacrylamide, methacrylic acid, linear or branched alkyl acrylates and methacrylates in which the alkyl group is not crystallizable, styrene, substituted styrene, and polyoxyalkylene.

Claim 108: The floor coating system according to any of claims 99-107, wherein the side-chain crystallizable polymer comprises at least one member selected from the group consisting of acrylic polymer, vinyl polymer, polyester, polyimide, polyolefin, polystyrene, polyether, polyalkylene oxide, polyalkyl phosphazene, poly amino acid, polyisocyanate, polyurethane, polysilane, and polysiloxane.

Claim 109: The floor coating system according to claim 108, wherein the side-chain crystallizable polymer comprises repeating units derived from at least two different monomers.

Claim 110: The floor coating system according to any of claims 99-109, wherein the side-chain crystallizable polymer comprises repeating units derived from at least one n-alkyl acrylate or methacrylate in which the alkyl group contains from 14 to 22 carbon atoms.

Claim 111: The floor coating system according to any of claims 99-110, wherein the side-chain crystallizable polymer contains from 1 wt % to 10 wt % of units derived from acrylic acid.

Claim 112: The floor coating system according to any of claims 99-111, wherein the side-chain crystallizable polymer comprises units derived from at least one polar monomer selected from polyoxyalkylene, acrylate, acrylamide, and methacrylamide.

Claim 113: The floor coating system according to any of claims 99-112, wherein the crystallizable side chains make up at least 50 percent of the volume of the side-chain crystallizable polymer.

Claim 114: The floor coating system according to any of claims 99-113, wherein the crystallizable side chains have a length greater than five times of a distance between the side chains.

Claim 115: The floor coating system according to any of claims 99-114, wherein the side-chain crystallizable polymer comprises repeating units of the formula

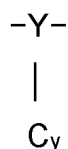

where Y is an organic radical forming part of a polymer backbone and C_y comprises a crystallizable moiety present in an amount that the side-chain crystallizable polymer has a heat of fusion of at least 20 Joules/gram.

5 Claim 116: The floor coating system according to any of claims 99-115, wherein the film-forming polymer does not comprise crystallizable side chains.

Claim 117: The floor coating system according to any of claims 99-116 wherein the side-chain crystallizable polymer is present in a cool-release layer composition and the film-forming polymer is present in a wear layer composition.

10 Claim 118: The floor coating system according to claim 117, wherein the cool-release layer composition further comprises a first volatile carrier comprising at least one member selected from the group consisting of water and organic solvent, and the wear layer composition further comprises a second volatile carrier comprising at least one member selected from the group consisting of water and organic solvent.

15 Claim 119: The floor coating system according to claim 117 or 118, wherein: (i) the side-chain crystallizable polymer is present as a first discontinuous phase in a first emulsion comprising a first volatile carrier, and (ii) the polymeric film forming agent is present as a second discontinuous phase in a second emulsion comprising a second volatile carrier.

20 Claim 120: The floor coating system according to claim 119, wherein the first emulsion is an aqueous emulsion and the second emulsion is an aqueous emulsion.

Claim 121: The floor coating system according to any of claims 117-120, wherein the cool-release layer composition comprises the side-chain crystalline polymer in an amount of at least 10 weight percent, based on layer weight.

25 Claim 122: The floor coating system according to any of claims 117-121, further comprising a base layer composition.

Claim 123: The floor coating system according to claim 122, wherein the base layer composition comprises at least one member selected from the group consisting of acrylic polymer, polyurethane, polyurea, epoxy polymer, polysiloxane, vinyl polymer, and styrene-butadiene polymer and a third volatile carrier.

30

Claim 124: The floor coating system according to any of claims 99-116, wherein the coating comprises a cool-release wear layer composition comprising both the side-chain crystallizable polymer and the film-forming polymer.

5 Claim 125: The floor coating system according to claim 124, further comprising a base layer composition.

Claim 126: The floor coating system according to claim 125, wherein the base layer composition comprises at least one member selected from the group consisting of acrylic polymer, polyurethane, polyurea, epoxy polymer, polysiloxane, vinyl polymer, and styrene-butadiene polymer.

10 Claim 127: The floor coating system according to any of claims 99-126, wherein the film-forming polymer is not a pressure-sensitive adhesive.

Claim 128: A coated floor comprising a flooring substrate and a temperature-releasable coating thereon, the coating comprising:

- 15 (A) a heat releasable component comprising a side chain crystalline polymer having an onset of melting temperature, T_0 , of at least 27°C (80°F); and
- (B) a film-forming polymer comprising at least one member selected from the group consisting of polyurethane, acrylic polymer, polysiloxane, polysilazane, polyester, polyamide, polyurea, epoxy
- 20 polymer, vinyl polymer, polyether, polyaldehyde, polyketone, and polycarbonate, wherein the film-forming polymer does not comprise crystalline side chains.

Claim 129: The coated floor according to Claim 128, wherein the side chain crystalline polymer has an onset of melting temperature, T_0 , of at least 29°C

25 (85°F).

Claim 130: A coated floor comprising:

- (A) a flooring substrate, and
- (B) a cool-releasable coating over the flooring substrate, the coating comprising:
- 30 (i) a polymeric adhesion composition which is substantially nontacky at or below about 7.2°C and which is tacky at 18°C, wherein the adhesive composition comprises a side-

chain crystallizable polymer having a heat of fusion of at least 20 Joules/g and an onset of melt temperature T_0 of from about 2°C to 18°C, and wherein the side-chain crystallizable polymer contains at least 50% by weight of repeating units of the formula

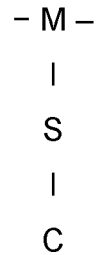

wherein M is an atom forming part of the backbone of the polymer and –S–C is a side chain in which S is a spacer unit and C is a crystallizable group, and wherein the length of the side chain is greater than five times the distance between adjacent side-chains in the polymer, and

(ii) a film-forming polymer comprising at least one member selected from the group consisting of polyurethane, acrylic polymer, polysiloxane, polysilazane, polyester, polyamide, polyurea, epoxy polymer, vinyl polymer, polyether, polyaldehyde, polyketone, and polycarbonate.

Claim 131: The coated floor according to claim 130, wherein the polymeric adhesion composition is substantially nontacky at or below 10°C.

Claim 132: The coated floor according to claim 130, wherein the polymeric adhesion composition is substantially nontacky at or below 12.8°C.

Claim 133: The coated floor according to claim 130, wherein the polymeric adhesion composition is substantially nontacky at or below 15.6°C.

Claim 134. A fluid coating composition that, when applied to a substrate, especially a flooring material, produces a selective temperature-responsive release (or trigger) layer over which can be applied one or more floor finish coatings such that, when it becomes desirable to remove the finish coating, the release layer reduces or eliminates the need for chemical stripping products by selectively interrupting the adhesion of the finish coats from the floor when

sufficient heat is applied to the floor surface to reach a characteristic, targeted stripping temperature that is significantly higher than the expected service temperature of the floor; wherein the temperature-triggered component of the release layer comprises one or more crystalline polymers, especially a side-chain crystalline polymer, also known as SCCP, that may be combined with chemical additives to augment or modify the crystalline behavior of the SCCP in order to improve its temperature response, modify its transition temperature, or modify the viscosity, flow or other physical characteristics of the polymer, particularly when it is above its transition temperature, in order to assist or control the release properties of the release layer.

Claim 135. A composition as in claim 134 where the SCCP (i) has a peak melting point, T_p , measured as defined below, of at most 80°C, preferably at most 60°C, particularly at most 55°C, and (ii) has a weight average molecular weight of at most 100,000 DA, preferably at most 50,000 Da and particularly at most 20,000 DA.

Claim 136. A composition as in claim 135 that is a dispersion in water where the active components are particles or droplets suspended or emulsified in water, or a mixture of water and volatile organic compounds, that is formulated for application to a substrate in order to create a solid temperature-triggered release layer after evaporation of the water and volatile compounds. Because an unmodified SCCP is unlikely to form a continuous, defect-free film under the expected conditions of application, wherein the room temperature is near 20°C, the composition may include both SCCP and one or more non-crystalline film-forming polymers, FFP, to assure that, after evaporation of water, the resulting release layer is continuous without cracking or other deformities, alternatively, the SCCP may be modified with FFP composition during formation of the polymer particles such that the combined dual composition functions both as a film-former and separately as a temperature-triggered release polymer.

Claim 137. A composition as in claim 136 wherein the FFP is an emulsion or water-reducible polymer and the composition optionally contains one or more volatile organic compounds or solvents that will dry on air evaporation of water to provide a cohesive and defect-free film with good adhesion to the substrate, the

FFP may be selected from one of the polymers commonly used for finishing floors or other substrates or it may simply be a commercially available coating product to which the SCCP dispersion may be added, or it may be a film-forming polymer that is selected because it is more suited for use in the trigger layer, said
5 polymers may be acrylic or modified acrylic, styrene-acrylic, polyurethane, polyether, vinyl, epoxy or other polymer commonly used to formulate surface coatings, wherein the SCCP-containing composition is not expected to perform as a durable surface finish, the selection of FFP may be chosen from polymers with a Minimum Film Formation Temperature, MFFT, at or preferably below 20°F
10 room temperature so that the use of solvents, coalescents or other volatile organic compounds are not required for film formation.

Claim 138. A maintenance system that comprises a substrate, e.g. a floor substrate or a vertical substrate, with a "wear layer" onto which is applied an SCCP-containing "trigger layer" followed by a "finish layer" wherein the three
15 layers are designed to work together more efficiently to facilitate maintenance according to the methods of claim.

Claim 139. A floor substrate or other surface requiring periodic maintenance and cleaning that is prepared, treated or coated with a more durable surface layer that has increased resistance to repeated cleanings under conditions of coating
20 removal compared to an ordinary substrate, such as a VCT tile which has a coating thereon of a polyurethane wear layer, wherein the wear layer may be part of the original manufacture or fabrication of the substrate, e.g. a polyurethane coated VCT sometimes referred to as a VET (vinyl enhanced tile), or it may be applied as a separate liquid base or sealer coating to the floor surface, e.g. a
25 conventional VCT, as the first part of the floor maintenance system.

Claim 140. A "wear layer" or base/sealer coating on the surface of the substrate that contains or is otherwise modified with an SCCP composition to enable the "wear layer" to also function as a "trigger layer" for the removal, preferably the
30 periodic release and removal, of finish layers, but which does not require replacement because it resists and may not be, wherein the 3-layer floor maintenance system described in claim 138 may be reduced to 2 layers instead, and the SCCP may not comply with the molecular weight limitations described in

claim 135 because it is desirable to retain the SCCP part of the “wear layer” intact for repeated maintenance cycles.

5 Claim 141. A substrate which (i) is a floor or (ii) can be secured to a substrate to provide a floor surface, for example a VCT tile, the substrate carrying a solid layer of a composition which comprises an SCC polymer and which can be triggered by heat.

Claim 142. A composition which comprises:

10 (1) an SCC polymer, preferably an SCC polymer which has a peak melting point, T_p , measured as defined above, of at most 80°C, preferably at most 60°C, particularly at most 50°C; and

(2) an ingredient which is useful as a floor finish, for example one of the materials commercially available for finishing vinyl composition floor tiles.

15 Claim 143. A substrate which (i) is a floor or (ii) can be secured to a substrate to provide a floor surface, for example a VCT tile, the substrate carrying a solid layer of a composition which comprises an SCC polymer and which can be triggered by heat.

20 Claim 144. A substrate according claim 143 wherein the SCC polymer has a peak melting point, T_p , measured as defined above, of at most 80°C, preferably at most 60°C, particularly at most 50°C.

Claim 145. A substrate according to claim 143 or 144 wherein the layer was formed by depositing on the substrate a composition containing an SCC polymer and water and optionally another solvent that can be removed by drying, followed by drying.

25 Claim 146. A substrate according to claim 143 or 144 wherein the layer was formed by (1) depositing a solvent-based composition, followed by removal of the solvent, or (2) melt deposition, or (3) depositing a liquid composition and converting the liquid composition to a solid form, for example using ultraviolet light or other electromagnetic radiation, electron beam radiation or chemically-
30 induced hardening.

Claim 147. A substrate according to any of claims 142-146 wherein the layer is a continuous non-tacky layer having a thickness of less than 10 microns.

Claim 148. A substrate according to any of claims 142-147 wherein the layer comprising the composition comprising the SCC polymer is the sole layer on the substrate.

5 Claim 149. A substrate according to any of claims 142-147 is wherein the layer comprising the composition comprising the SCC polymer is one of two or more layers on the substrate, for example, there can be a base layer between the substrate and the layer comprising the composition comprising the SCC polymer, and/or there can be one or more layers between the layer comprising the SCC polymer and the ambient atmosphere, and/or there can be one, two or more
10 layers of a conventional floor finish, one being an upper layer exposed to the ambient atmosphere, and/or there can be a tie layer which is between the layer comprising the composition comprising the SCC polymer and an exterior layer of a floor finish.

Claim 150. A coated floor comprising
15 (1) a flooring substrate, and
(2) a solid non-tacky coating of a Releasable SCC Polymer Composition which (i) is adjacent to the substrate, (ii) can be triggered by heat, and (iii) comprises a sidechain crystalline polymer (SCC polymer) which has an onset of melting temperature, T_0 , which is higher than any
20 temperature to which the substrate will be exposed during normal use, and a peak melting temperature (T_p) which is less than any temperature which will damage the substrate, preferably a T_p of at most 120°C.

Claim 151. A coated floor according to claim 150 wherein the SCC polymer has one or more of the following characteristics
25 (a) the SCC polymer has a T_0 of at least 10°C, or at least 15°C, or at least 27°C, or at least 35°C, or at least 40°C,
(b) the SCC polymer has a T_p of at most 80°C, preferably at most 60°C, particularly at most 50°C.,
(c) the SCC polymer has a T_p and a T_0 , measured in degrees
30 centigrade, such that the value of $(T_p - T_0)$ is less than $T_p^{0.7}$, preferably less than 25°C, preferably less than 20°C, particularly less than 15°C,

(d) the SCC polymer has a weight average molecular weight of at most 100,000 Da, preferably at most 50,000 Da, particularly at most 20,000 Da, and in some applications less than 10,000 Da,

(e) the SCC polymer has been prepared by an emulsion

5 polymerization process which produces particles having a size of 0.07 to 0.5 μm , particularly 0.1 to 0.25 μm ,

(f) the SCC polymer comprises units derived from one or more n-alkyl acrylates or methacrylates in proportions by weight such that the average length of the n-alkyl groups is 16-20, for example 16-18, carbon atoms, the n-alkyl groups for example containing 8-22 carbon atoms, and the
10 polymer for example containing 90 to 98%, e.g. 94 to 97%, by weight of the units derived from one or more n-alkyl acrylates.

(g) the SCC polymer comprises 90-98%, e.g. 94-97%, by weight of units derived from octadecyl acrylate and hexadecyl acrylate, the ratio of
15 octadecyl acrylate to hexadecyl acrylate units being for example 16 to 2.

(h) the SCC polymer contains, for example in amount greater 1%, for example 1-4%, e.g. 2-4%, or 1-3%, or 1-2%, units derived from (i) a comonomer containing a carboxylic group, e.g. methacrylic acid, and/or (ii) a comonomer containing a hydroxyl group, e.g. hydroxyethyl acrylate,
20 hydroxyethyl methacrylate hydroxypropyl acrylate or hydroxypropyl methacrylate.

(i) the SCC polymer has a heat of fusion of at least 20 Joules/g

Claim 152. A coated floor according to claim 150 or 151 wherein the Releasable SCC polymer coating comprises a matrix polymer.

25 Claim 153. A coated floor according to claim 152 wherein the matrix polymer has one or more of the following characteristics.

(a) the matrix polymer has a minimum film forming temperature (MFFT) which is at most 20°C,

(b) the matrix polymer has a minimum film forming temperature
30 (MFFT) which is at least 20°C

(c) the matrix polymer is miscible with water,

(d) the matrix polymer is an acrylic or styrene-acrylic polymer prepared by emulsion polymerization, for example a cross-linked styrene-ethylhexylacrylate-methacrylic acid polymer, a styrene-butylacrylate--methacrylic acid polymer, a styrene-butylacrylate-methylmethacrylate-methacrylic acid polymer, or an isobutyl methacrylate-methylmethacrylate-hydroxyethyl acrylate,

(e) the matrix polymer is composed of particles which are smaller than the particles of the SCC polymer, and

(f) the matrix polymer forms a continuous phase in which the SCC polymer is dispersed in the form of particles.

Claim 154. A coated floor according to claim 152 or 153 wherein the Releasable SCC Polymer Composition comprises 30-80%, e.g. 40-70% or 50-60%, of the SCC polymer and 20-70%, for example 30-60% or 40-50%, of the matrix polymer.

Claim 155. A coated floor according to any of the preceding claims wherein the solid coating of the Releasable SCC Polymer Composition has a thickness of less than 10 μm , preferably less than 2 μm , e.g. less than 1 μm .

Claim 156. A coated floor according to any of claims 150-155 wherein the solid coating of the Releasable SCC Polymer Composition directly contacts the flooring substrate, or is separated from the flooring substrate by an intermediate layer comprising a polymeric composition which does not include an SCC polymer.

Claim 157. A coated floor according to any of claims 150-156 wherein the flooring substrate is a vinyl composition tile.

Claim 158. A coated floor according to any of claims 150-157 which comprises an exterior coating on top of the Releasable SCC polymer coating, for example an exterior coating which comprises one or more coatings of a commercially available flooring finish.

Claim 159. A liquid composition comprising (1) an SCC polymer which has an onset of melting temperature, T_0 , of at least 27°C. and a peak melting temperature (T_p) of at most 120°C. and (2) a matrix polymer.

Claim 160. A liquid composition according to claim 159 wherein the SCC polymer has one or more of the following characteristics

- (a) the SCC polymer has a T_0 of at least 10°C, or at least 15°C, or at least 27°C, or at least 35°C, or at least 40°C,
- 5 (b) the SCC polymer has a T_p of at most 80°C, preferably at most 60°C, particularly at most 50°C.,
- (c) the SCC polymer has a T_p and a T_0 , measured in degrees centigrade, such that the value of $(T_p - T_0)$ is less than $T_p^{0.7}$, preferably less than 25°C, preferably less than 20°C, particularly less than 15°C,
- 10 (d) the SCC polymer has a weight average molecular weight of at most 100,000 Da, preferably at most 50,000 Da, particularly at most 20,000 Da, and in some applications less than 10,000 Da,
- (e) the SCC polymer has been prepared by an emulsion polymerization process which produces particles having a size of 0.07 to
- 15 0.5 μm , particularly 0.1 to 0.25 μm ,
- (f) the SCC polymer comprises units derived from one or more n-alkyl acrylates or methacrylates in proportions by weight such that the average length of the n-alkyl groups is 16-20, for example 16-18, carbon atoms, the n-alkyl groups for example containing 8-22 carbon atoms, and the
- 20 polymer for example containing 90 to 98%, e.g. 94 to 97%, by weight of the units derived from one or more n-alkyl acrylates.
- (g) the SCC polymer comprises 90-98%, e.g. 94-97%, by weight of units derived from octadecyl acrylate and hexadecyl acrylate, the ratio of octadecyl acrylate to hexadecyl acrylate units being for example 16 to 2.
- 25 (h) the SCC polymer contains, for example in amount greater than 1%, for example 1-4%, e.g. 2-4%, or 1-3%, or 1-2%, units derived from (i) a comonomer containing a carboxylic group, e.g. methacrylic acid, and/or (ii) a comonomer containing a hydroxyl group, e.g. hydroxyethyl acrylate, hydroxyethyl methacrylate hydroxypropyl acrylate or hydroxypropyl
- 30 methacrylate.
- (i) the SCC polymer has a heat of fusion of at least 20 Joules/g

161. A liquid composition according to claim 159 or 160 wherein the matrix polymer has one or more of the following characteristics.

- (a) the matrix polymer has a minimum film forming temperature (MFFT) which is at most 20°C,
- 5 (b) the matrix polymer has a minimum film forming temperature (MFFT) which is at least 20°C
- (c) the matrix polymer is miscible with water,
- (d) the matrix polymer is an acrylic or styrene-acrylic polymer prepared by emulsion polymerization, for example a cross-linked styrene-
10 ethylhexylacrylate-methacrylic acid polymer, a styrene-butylacrylate--
methacrylic acid polymer, a styrene-butylacrylate-methylmethacrylate-
methacrylic acid polymer, or an isobutyl methacrylate-methylmethacrylate-
hydroxyethyl acrylate,
- (e) the matrix polymer is composed of particles which are smaller than
15 the particles of the SCC polymer, and
- (f) the matrix polymer forms a continuous phase in which the SCC polymer is dispersed in the form of particles.

FIG. 1

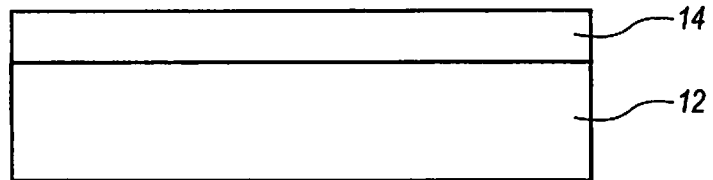

FIG. 2

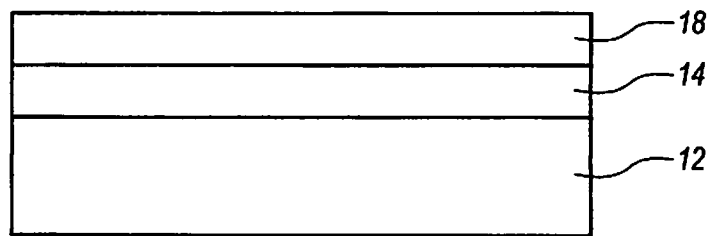

FIG. 3

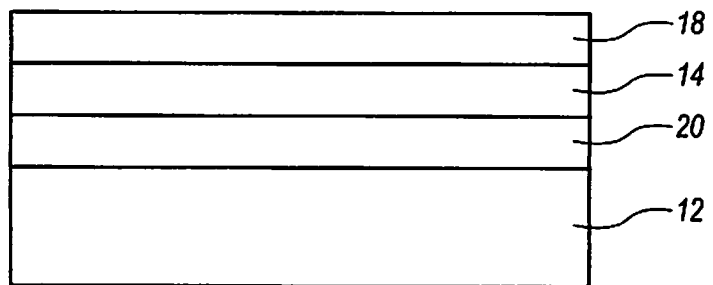

Fig 4

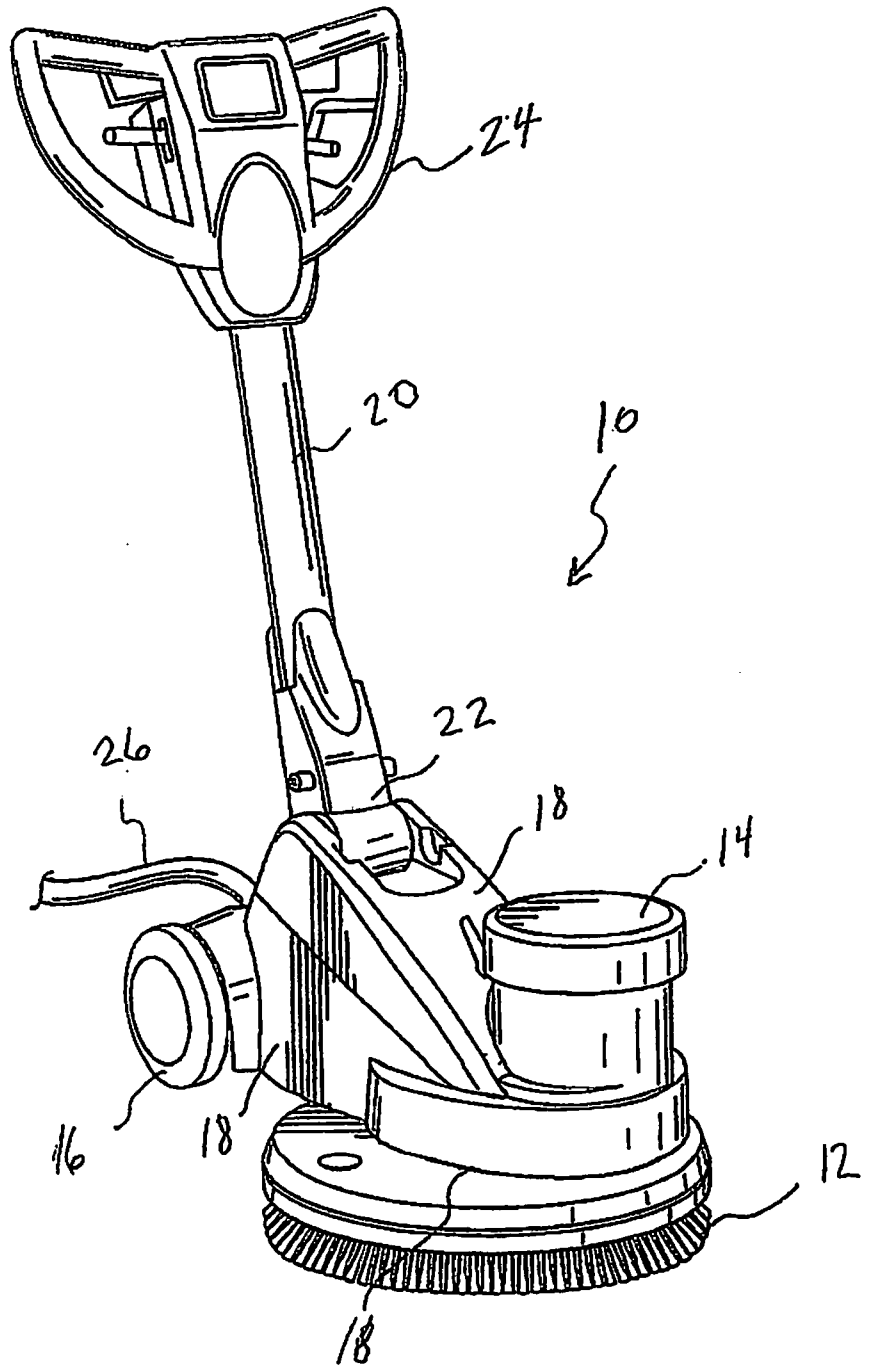

Fig 5

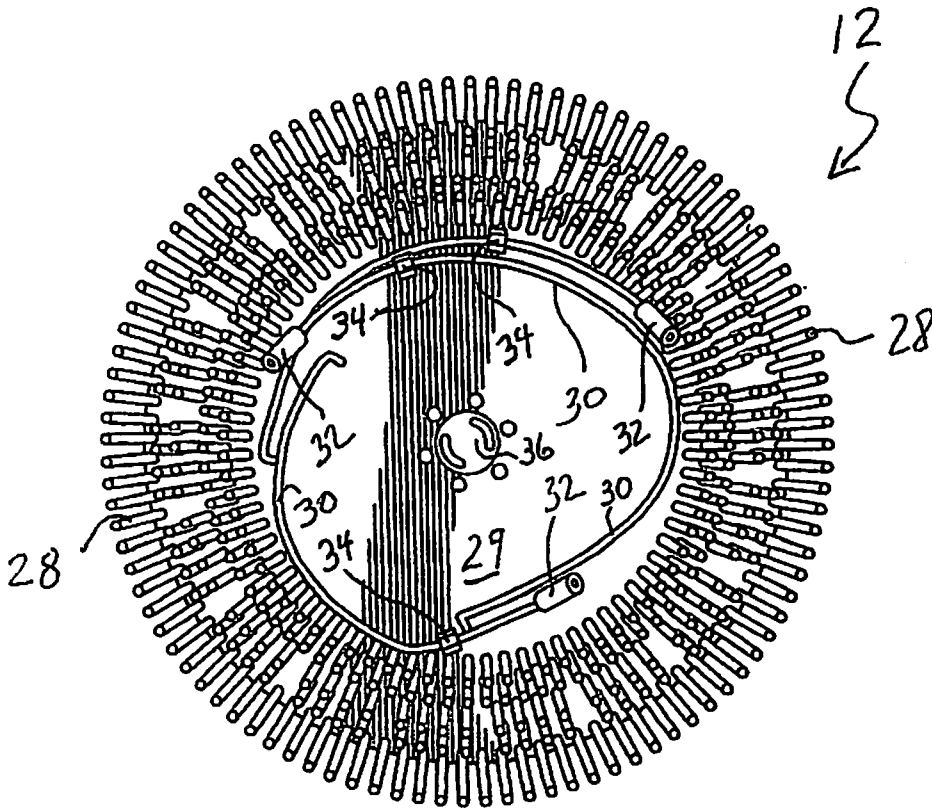

Fig 6

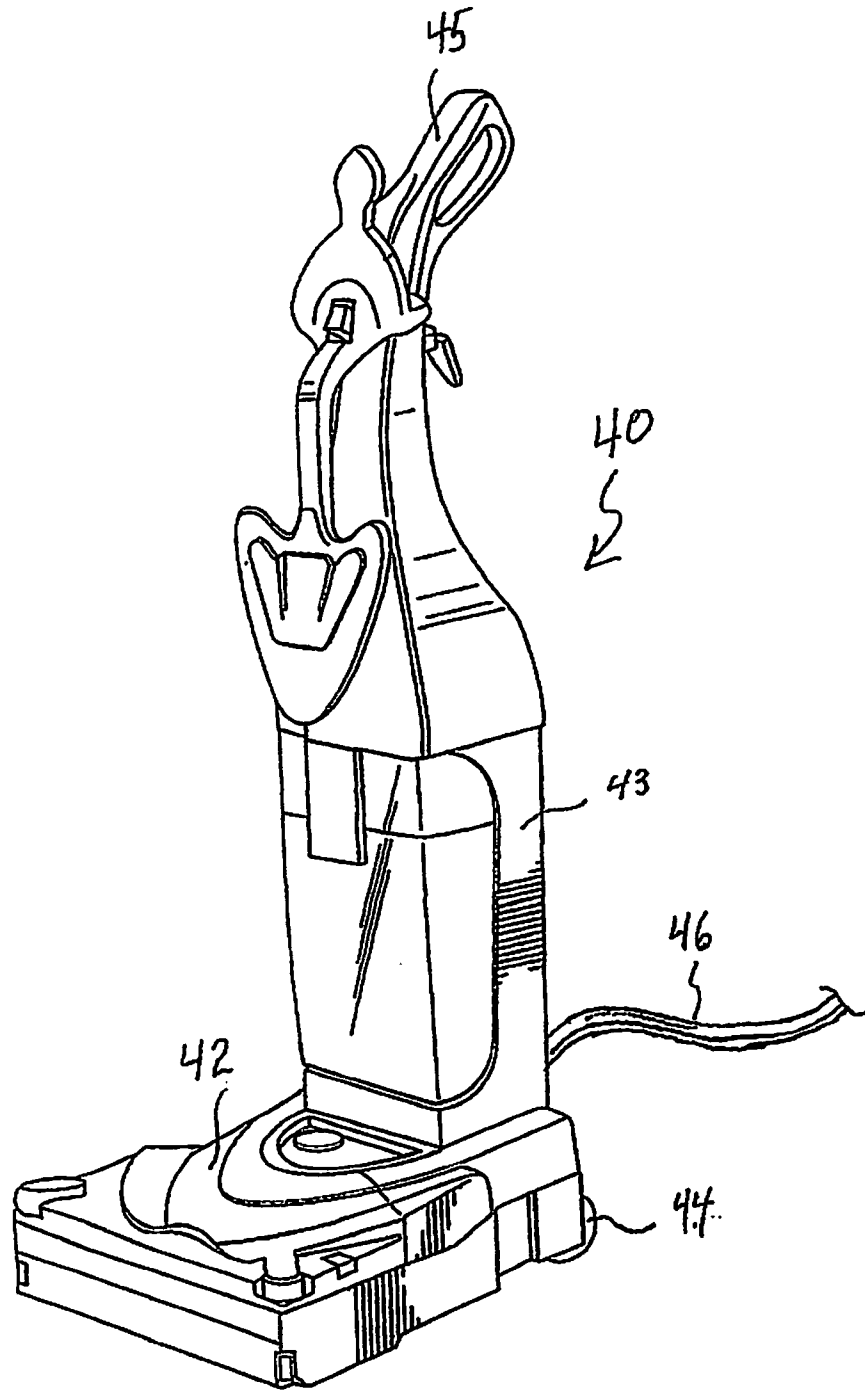

Fig 7

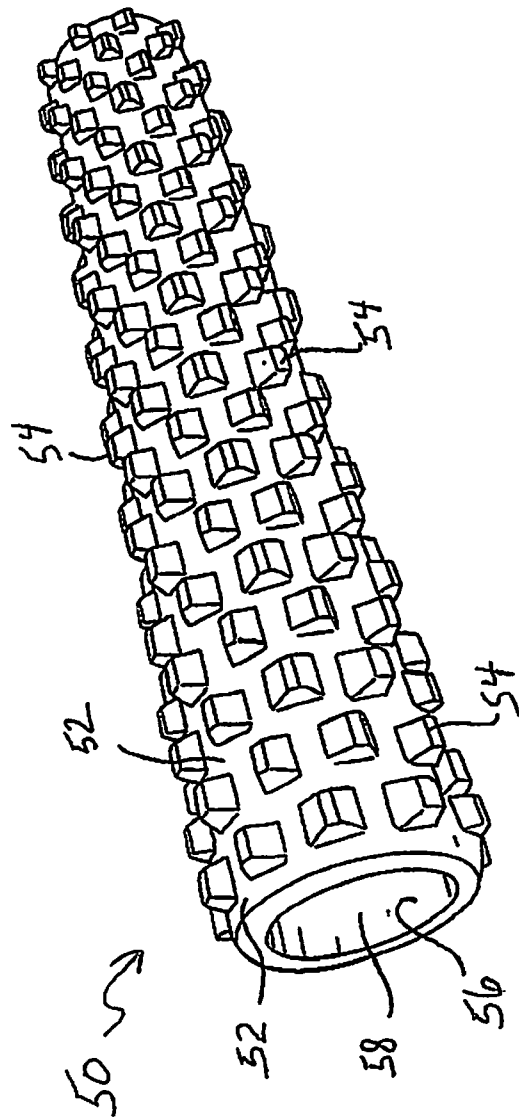

Fig 8

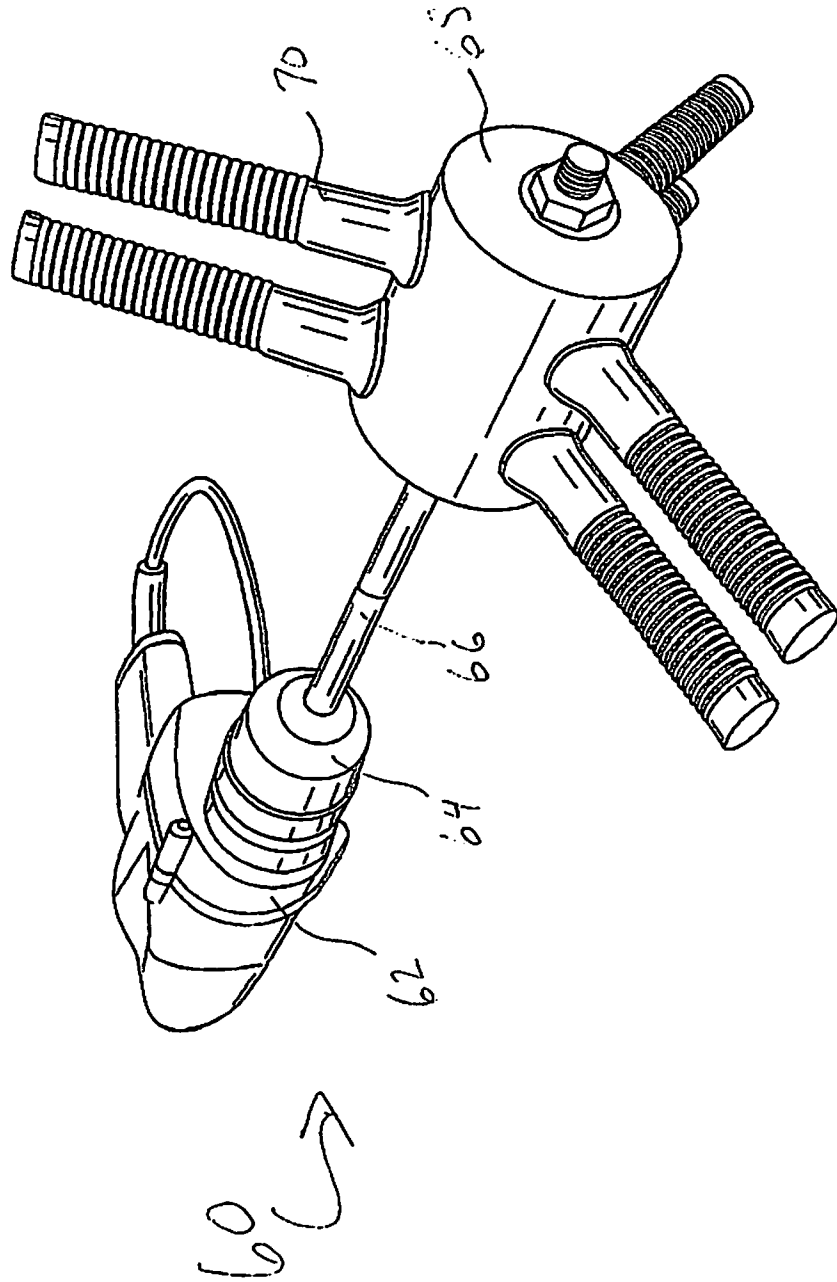
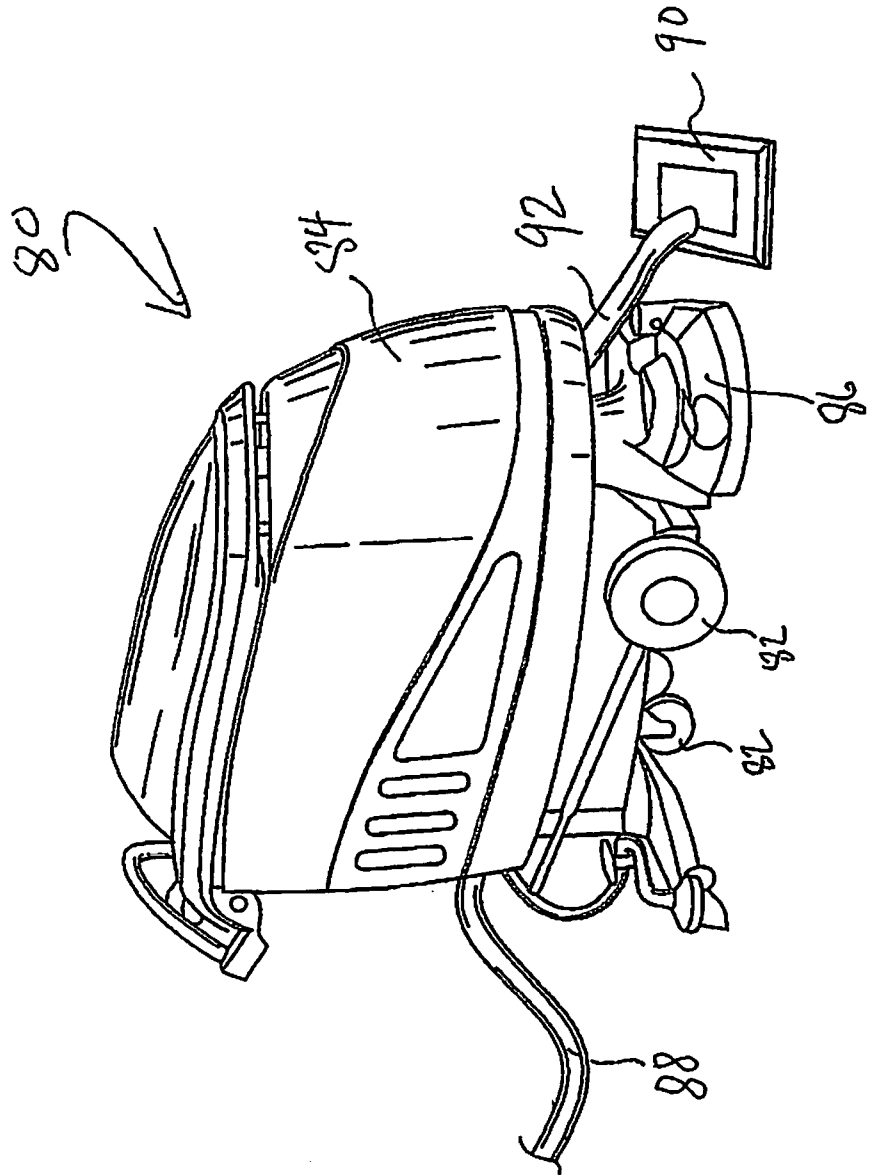

Fig 9



INTERNATIONAL SEARCH REPORT

International application No PCT/US2016/049117

A. CLASSIFICATION OF SUBJECT MATTER
 INV. C09D133/04
 ADD.

According to International Patent Classification (IPC) or to both national classification and IPC

B. FIELDS SEARCHED

Minimum documentation searched (classification system followed by classification symbols)
 C09D

Documentation searched other than minimum documentation to the extent that such documents are included in the fields searched

Electronic data base consulted during the international search (name of data base and, where practicable, search terms used)
 EPO-Internal, WPI Data

C. DOCUMENTS CONSIDERED TO BE RELEVANT

Category*	Citation of document, with indication, where appropriate, of the relevant passages	Relevant to claim No.
X	WO 2010/068279 A1 (LANDEC CORP [US]; PARKER ROBERT [US]; SCHAFER JULIAN E [US]; BITLER ST) 17 June 2010 (2010-06-17) page 16 - page 17; claims 1-12 -----	99-128, 134-137, 142, 159-161
X	WO 98/25710 A1 (LANDEC CORP) 18 June 1998 (1998-06-18) page 33 - page 38; claims 1-15 page 18 - page 23; examples 1-16 -----	99-128, 134-137, 142, 159-161
X	EP 0 471 767 A1 (LANDEC LAB INC [US]) 26 February 1992 (1992-02-26) page 13 - page 14; claims 1-23 -----	99-128, 134-137, 142, 159-161
	-/--	

Further documents are listed in the continuation of Box C. See patent family annex.

* Special categories of cited documents :

<p>"A" document defining the general state of the art which is not considered to be of particular relevance</p> <p>"E" earlier application or patent but published on or after the international filing date</p> <p>"L" document which may throw doubts on priority claim(s) or which is cited to establish the publication date of another citation or other special reason (as specified)</p> <p>"O" document referring to an oral disclosure, use, exhibition or other means</p> <p>"P" document published prior to the international filing date but later than the priority date claimed</p>	<p>"T" later document published after the international filing date or priority date and not in conflict with the application but cited to understand the principle or theory underlying the invention</p> <p>"X" document of particular relevance; the claimed invention cannot be considered novel or cannot be considered to involve an inventive step when the document is taken alone</p> <p>"Y" document of particular relevance; the claimed invention cannot be considered to involve an inventive step when the document is combined with one or more other such documents, such combination being obvious to a person skilled in the art</p> <p>"&" document member of the same patent family</p>
---	---

Date of the actual completion of the international search 10 November 2016	Date of mailing of the international search report 23/11/2016
---	--

Name and mailing address of the ISA/ European Patent Office, P.B. 5818 Patentlaan 2 NL - 2280 HV Rijswijk Tel. (+31-70) 340-2040, Fax: (+31-70) 340-3016	Authorized officer Jung, Andreas
--	---

INTERNATIONAL SEARCH REPORT

International application No
PCT/US2016/049117

C(Continuation). DOCUMENTS CONSIDERED TO BE RELEVANT		
Category*	Citation of document, with indication, where appropriate, of the relevant passages	Relevant to claim No.
X	<p>US 5 156 911 A (STEWART RAY F [US]) 20 October 1992 (1992-10-20) cited in the application</p> <p>column 12 - column 16; claims 1-20 -----</p>	<p>99-128, 134-137, 142, 159-161</p>
A	<p>GB 1 125 451 A (JOHNSON & SON INC S C) 28 August 1968 (1968-08-28) the whole document -----</p>	<p>1-161</p>

INTERNATIONAL SEARCH REPORT

Information on patent family members

International application No

PCT/US2016/049117

Patent document cited in search report	Publication date	Patent family member(s)	Publication date	
WO 2010068279	A1	17-06-2010	US 2010247900 A1	30-09-2010
			US 2015219505 A1	06-08-2015
			WO 2010068279 A1	17-06-2010

WO 9825710	A1	18-06-1998	AU 5697298 A	03-07-1998
			CA 2274643 A1	18-06-1998
			DE 69716125 D1	07-11-2002
			DE 69716125 T2	05-06-2003
			DE 69732671 D1	07-04-2005
			DE 69732671 T2	06-04-2006
			DK 0949975 T3	10-02-2003
			EP 0949975 A1	20-10-1999
			EP 1238714 A1	11-09-2002
			JP 4326026 B2	02-09-2009
			JP 2001507726 A	12-06-2001
			US 6199318 B1	13-03-2001
			WO 9825710 A1	18-06-1998

EP 0471767	A1	26-02-1992	AT 142557 T	15-09-1996
			AU 5549590 A	29-11-1990
			CA 2015753 A1	11-11-1990
			DE 69028528 D1	17-10-1996
			DE 69028528 T2	24-04-1997
			EP 0471767 A1	26-02-1992
			HK 1007989 A1	30-04-1999
			JP 3204455 B2	04-09-2001
			JP 3333140 B2	07-10-2002
			JP 3410692 B2	26-05-2003
			JP 3541194 B2	07-07-2004
			JP H04507425 A	24-12-1992
			JP H11246395 A	14-09-1999
			JP 2000144086 A	26-05-2000
			JP 2002322448 A	08-11-2002
			NZ 233532 A	26-11-1991
			US 5387450 A	07-02-1995
			WO 9013420 A1	15-11-1990

US 5156911	A	20-10-1992	US 5156911 A	20-10-1992
			ZA 9003620 B	27-02-1991

GB 1125451	A	28-08-1968	NONE	
