

(12) INTERNATIONAL APPLICATION PUBLISHED UNDER THE PATENT COOPERATION TREATY (PCT)

(19) World Intellectual Property Organization  
International Bureau



(43) International Publication Date  
13 February 2003 (13.02.2003)

PCT

(10) International Publication Number  
WO 03/012239 A1

(51) International Patent Classification<sup>7</sup>: E06B 5/16,  
B66B 13/30

(21) International Application Number: PCT/IT01/00418

(22) International Filing Date: 30 July 2001 (30.07.2001)

(25) Filing Language: English

(26) Publication Language: English

(71) Applicant (for all designated States except US): WITTUR  
S.P.A. [IT/IT]; Via Macedonio Melloni, 7, I-43052 Colomo  
(IT).

(72) Inventor; and

(75) Inventor/Applicant (for US only): GIORGIONI, Paolo  
[IT/IT]; Via Monte Cagno, 13/A, I-42039 Ligonchio (IT).

(74) Agent: GOTRA, Stefano; Bugnion S.P.A., Via Garibaldi,  
22, I-43100 Parma (IT).

(81) Designated State (national): HU.

(84) Designated States (regional): European patent (AT, BE,  
CH, CY, DE, DK, ES, FI, FR, GB, GR, IE, IT, LU, MC,  
NL, PT, SE, TR).

Declarations under Rule 4.17:

- as to applicant's entitlement to apply for and be granted a patent (Rule 4.17(ii)) for the following designations AE, AG, AL, AM, AT, AU, AZ, BA, BB, BG, BR, BY, BZ, CA, CH, CN, CO, CR, CU, CZ, DE, DK, DM, DZ, EC, EE, ES, FI, GB, GD, GE, GH, GM, HR, HU, ID, IL, IN, IS, JP, KE, KG, KP, KR, KZ, LC, LK, LR, LS, LT, LU, LV, MA, MD, MG, MK, MN, MW, MX, MZ, NO, NZ, PL, PT, RO, RU, SD, SE, SG, SI, SK, SL, TJ, TM, TR, TT, TZ, UA, UG, UZ, VN, YU, ZA, ZW, ARIPO patent (GH, GM, KE, LS, MW, MZ, SD, SL, SZ, TZ, UG, ZW), Eurasian patent (AM, AZ, BY, KG, KZ, MD, RU, TJ, TM), European patent (AT, BE, CH, CY, DE, DK, ES, FI, FR, GB, GR, IE, IT, LU, MC, NL, PT, SE, TR), OAPI patent (BF, BJ, CF, CG, CI, CM, GA, GN, GQ, GW, ML, MR, NE, SN, TD, TG)
- of inventorship (Rule 4.17(iv)) for US only

Published:

- with international search report

For two-letter codes and other abbreviations, refer to the "Guidance Notes on Codes and Abbreviations" appearing at the beginning of each regular issue of the PCT Gazette.

(54) Title: FIRE BARRIER DOOR IN PARTICULAR FOR ACCESSING SHAFTS OF LIFTS OR THE LIKE

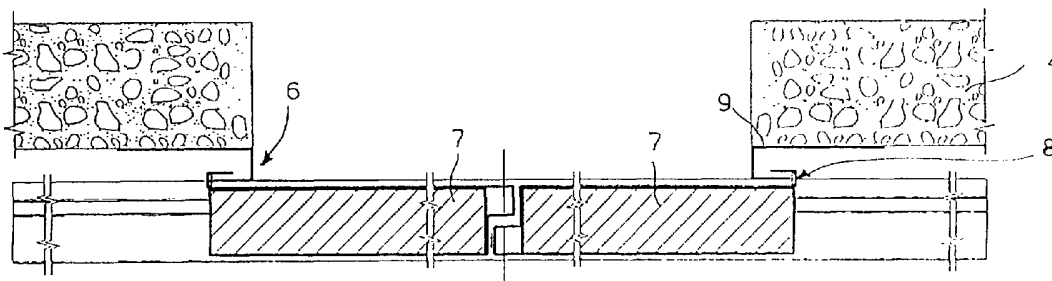

(57) Abstract: A fire barrier door (1) in particular for accessing shafts (2) of lifts or the like comprises a frame (6) mounted on the sides delimiting an opening (5) for accessing said shaft (2) and at least a panel (7) mounted in sliding fashion relative to said frame (6) and movable between an open position and a closed position. Further provided is at least a labyrinth structure (8) generated, in the closed position of the door (1), by the interaction of a first portion (8a) integral with the frame (6) and of a second portion (8b) integral with the outer profile of the door. The frame (6) is obtained by means of supporting section bars (9) mounted directly on the sides delimiting said opening (5) and complementing the first portion (8a) defining the labyrinth structure (8).



WO 03/012239 A1

FIRE BARRIER DOOR IN PARTICULAR FOR ACCESSING SHAFTS OF LIFTS OR  
THE LIKE

TECHNICAL FIELD AND BACKGROUND ART.

5 The present invention relates to a fire barrier door, in particular for accessing shafts of lifts or the like.

As is well known, lifts are constructed by means of a booth translating vertically inside a shaft that mutually connects multiple floors. The booth is provided with a door, generally constructed with multiple sliding panels, whilst each floor is provided with a  
10 door that prevents access to the shaft in the absence of the booth at the floor.

The shaft housing the booth constitutes a connecting tunnel between the floors, particularly dangerous in case of fire because it is transformed into a sort of chimney and allows the flames to spread between contiguous floors.

To prevent flames from spreading, so-called fire barrier doors are known, provided with  
15 sealing labyrinths that do not allow the shaft to interface directly with the floor.

For this purpose, known fire barrier doors comprise a frame mounted on the side that delimit the opening providing access to the lift shaft. This frame is provided in particular with lateral jambs and with an upper cross member in which the door, generally constructed with sliding panels, is mounted.

20 When the door is closed, the profile of the outer perimeter of the panels interacts with the profile of the jambs and of the cross member and generates seal means constituted by a labyrinth structure that prevents flames from spreading.

Known fire barrier doors have some drawbacks. The supporting frame constructed with jambs and cross members requires masonry works to modify the profile of the opening  
25 providing access to the compartment and create a housing in which the frame itself can

be stably fastened.

#### DISCLOSURE OF INVENTION.

The purpose of the present invention is to eliminate the aforesaid drawbacks, making available a fire barrier door that does not need masonry works to position lateral jambs  
5 or horizontal cross elements, simplifying its installation especially in case of renovation works.

Said aims are fully achieved by the fire barrier door of the present invention, that is characterised by the content of the claims set out below and in particular in that it comprises a frame obtained by means of support sections mounted directly on the sides  
10 delimiting said opening and integrating a first portion defining the labyrinth structure.

#### BRIEF DESCRIPTION OF DRAWINGS.

This and other characteristics shall become more readily apparent from the description that follows of a preferred embodiment illustrated, purely by way of non limiting example, in the accompanying drawing tables, in which:

- 15 - Figure 1 shows a perspective view of a fire barrier door according to the present invention;
- Figure 2 shows a view of the door of Figure 1, sectioned according to a horizontal plane;
- Figure 3 shows a view of the door of Figure 1, section according to a vertical plane;
- 20 - Figures 4 and 5 show a possible embodiment variation of the door shown in Figure 2;
- Figure 6 shows an enlarged detail of Figure 1.

#### BEST MODE FOR CARRYING OUT THE INVENTION.

With reference to the figures, the reference number 1 globally indicates a fire barrier door.  
25 In the example illustrated in the figure, the aforesaid door is interposed between a shaft

2 of a lift and one of the floors 3 connected by the lift itself. The shaft and the floor are delimited by a wall 4.

As shown in the figure, the connection between the shaft 2 and the floor 3 is achieved by means of an opening 5 obtained in the wall 4 and of substantially rectangular shape delimited by vertical sides and horizontal sides. The door 1 is therefore housed between  
5 the shaft 2 and the floor 3 in proximity to the opening 5.

Along the sides of the opening 5, a frame 6 is fastened whereon two panels 7, able to slid along opposite directions, are mounted.

The direction of translation of the two panels is horizontal and the two panels are movable  
10 between an open position, in which it is possible to access the compartment 2 and in particular the booth of the lift present at the floor, and a closed position illustrated in Figure 1), in which access to the shaft 2 is prevented.

When the door is closed as shown in Figure 1), the outer profile of the two panels interacts with the profile of the frame and generates a labyrinth structure 8 that prevents  
15 flames from spreading.

In particular, the labyrinth structure is obtained by means of a first portion 8a associated to the frame 6 and a second portion 8b associated to the outer profile of the door.

For this purpose the frame 6 is originally constructed by means of support section bars 9 mounted directly on the vertical sides and on the upper horizontal side that delimit the  
20 opening providing access to the shaft. The installation of the support section bars 9 is accomplished without masonry works, by means of simple fastening with threaded elements 10.

Moreover, the aforesaid supporting section bars 9 originally complement the first portion 8a defining the labyrinth structure 8.

25 In regard to the vertical sides of the opening, the supporting section bars 9 comprise a first

folded plate on each side, provided with the first portion 8a having substantially "C" shaped section.

The "C" shaped section is so positioned as to exhibit a first and a second segment, respectively substantially perpendicular and parallel to the direction of sliding of the corresponding panel. The first and the second segment make up the first portion 8a of the labyrinth structure and interact with the outer profile of the corresponding panel. This outer profile complements the second portion 8b of the labyrinth structure because it has, in turn, a substantially "C" shaped section whose segment parallel to the direction of sliding of the panel is superposed to the second segment of the respective lateral profile, when the door is in the closed position.

In addition to the vertical sides of the opening, the supporting section bars comprise a second folded sheet place positioned horizontally on the upper side of the opening. This horizontal section bar also comprises a portion having substantially "C" shaped section that constitutes the first portion 8a of the labyrinth structure.

In particular in the case of the support section bars positioned on the vertical sides of the opening, a sustaining bracket 11 can be provided, having a first end mounted directly on the sides delimiting the opening for accessing the shaft and a second end connected to the first portion of the labyrinth structure.

Figures 4 and 5 show two possible embodiments of the fire barrier door of the present invention. In Figure 4, the supporting section bars are mounted in such a way as to project internally to the opening providing access to the compartment. In Figure 5, the supporting section bars are mounted externally to the perimeter of the opening providing access to the shaft.

## CLAIMS

1. Fire barrier door (1) in particular for accessing shafts (2) of lifts or the like, of the type comprising:
  - a frame (6) mounted on the sides delimiting an opening (5) for accessing said compartment (2);
  - at least a panel (7) mounted in sliding fashion relative to said frame (6) and movable between an open position and a closed position;
  - at least a labyrinth structure (8) generated, in the closed position of said door (1), by the interaction of a first portion (8a) integral with the frame (6) and of a second portion (8b) integral with the outer profile of the door, to generate an obstacle against the spreading of fires;
  - characterised in that said frame (6) is obtained by means of supporting section bars (9) mounted directly on the sides delimiting said opening (5) and complementing said first portion (8a) defining the labyrinth structure (8).
2. A door as claimed in claim 1, characterised in that said supporting profiles (9) comprise at least a first folded plate positioned on at least a vertical side of said opening (5).
3. A door as claimed in claim 1, characterised in that said folded plate comprises a portion of substantially "C" shaped section, having a first segment substantially perpendicular to the direction of sliding of the panel and a second segment substantially parallel to the direction of sliding of the panel, said first and second segment constituting said first portion of the labyrinth structure.
4. A door as claimed in claim 1, characterised in that said supporting section bars (9) comprise a second folded plate positioned on the upper side of said opening (5).
5. A door as claimed in claim 4, characterised in that said second folded plate

comprises a portion having substantially "C" shaped section that constitutes said first portion of the labyrinth structure.

6. A door as claimed in any of the previous claims, characterised in that said supporting section bars (9) comprise a support bracket (11) having a first end mounted  
5 directly on the sides delimiting said opening (5) and a second end connected to said first portion (8) of the labyrinth structure (8a).

7. A door as claimed in any of the previous claims, characterised in that said supporting profiles (9) project internally to the opening (5) providing access to the shaft  
(2).

10 8. A door as claimed in any of the claims from 1 to 6, characterised in that said supporting profiles (9) are mounted externally to the perimeter of the opening (5) providing access to the shaft (2).

9. A lift of the type comprising a floor door and a booth door, characterised in that the floor door is a fire barrier door (1) according to any of the previous claims.

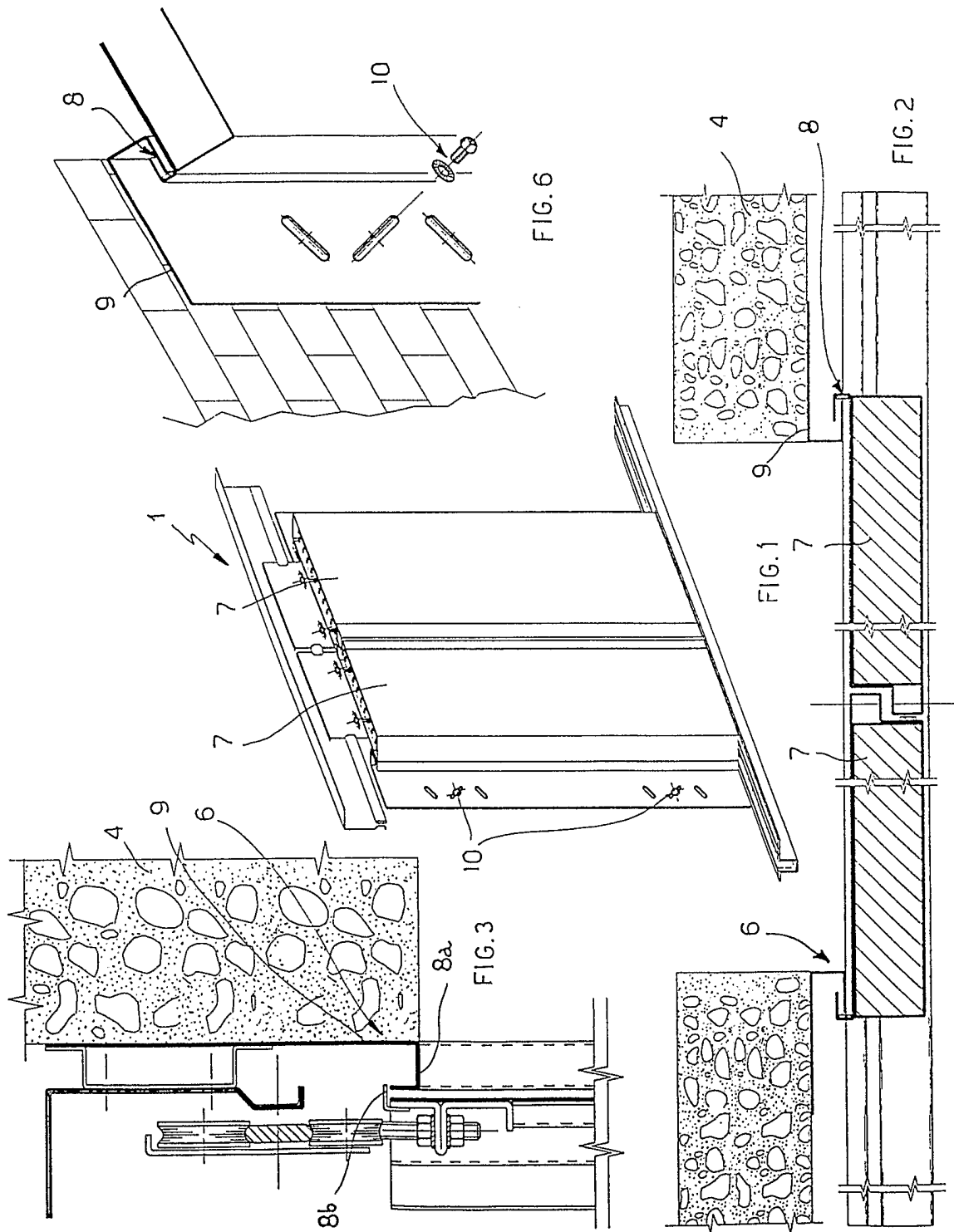

2/3

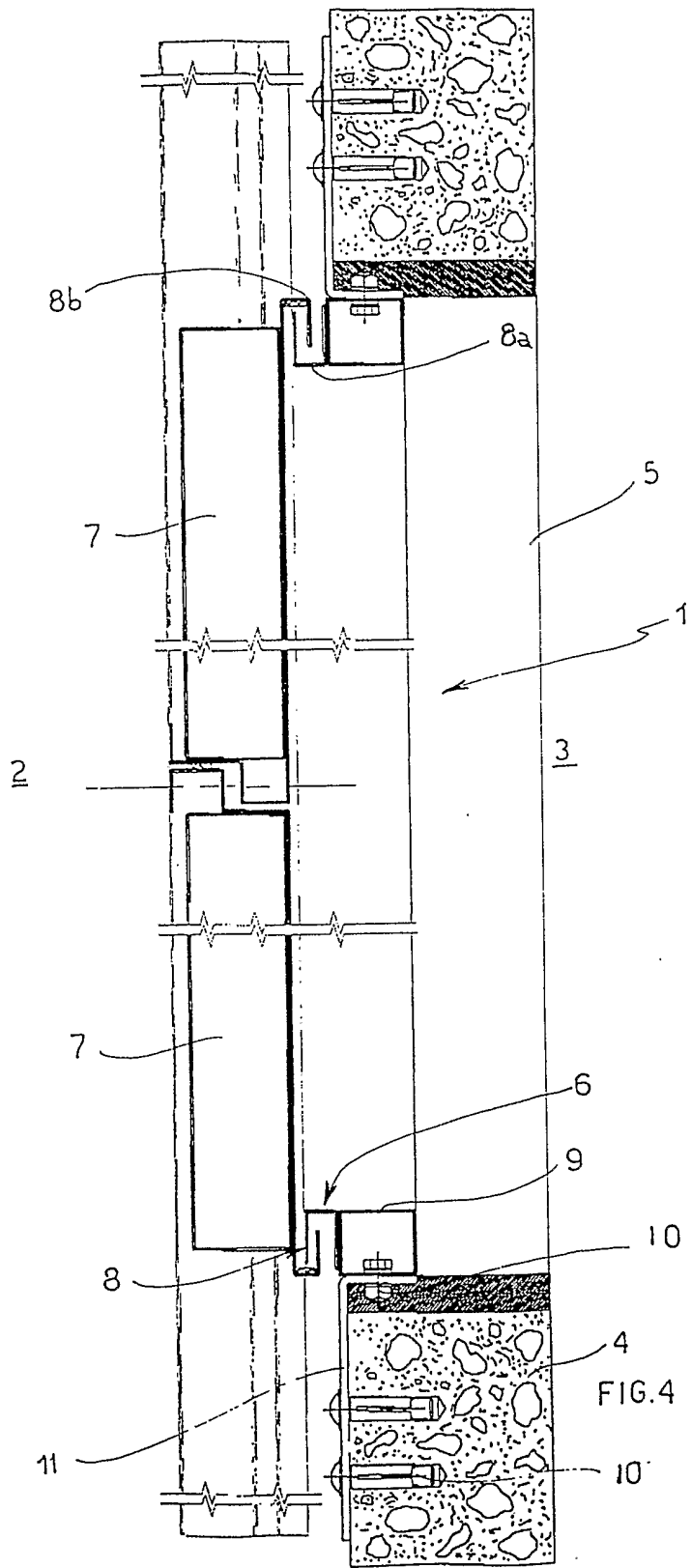

3 | 3

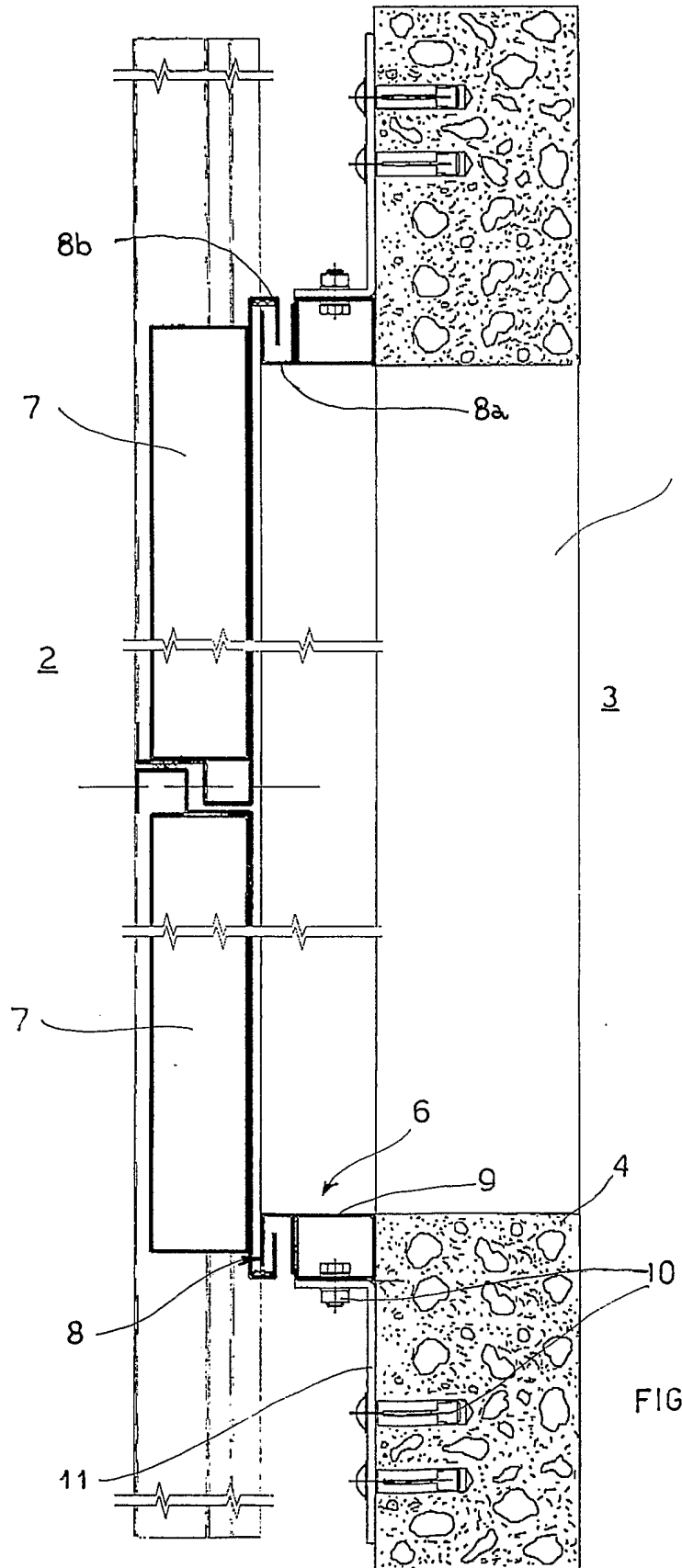

FIG

INTERNATIONAL SEARCH REPORT

International Application No  
PCT/IT 01/00418

**A. CLASSIFICATION OF SUBJECT MATTER**  
IPC 7 E06B5/16 B66B13/30

According to International Patent Classification (IPC) or to both national classification and IPC

**B. FIELDS SEARCHED**  
Minimum documentation searched (classification system followed by classification symbols)  
IPC 7 E06B B66B

Documentation searched other than minimum documentation to the extent that such documents are included in the fields searched

Electronic data base consulted during the international search (name of data base and, where practical, search terms used)  
EPO-Internal

**C. DOCUMENTS CONSIDERED TO BE RELEVANT**

Category	Citation of document, with indication, where appropriate, of the relevant passages	Relevant to claim No.
X	GB 2 352 754 A (SEMATIC ITALIA SPA) 7 February 2001 (2001-02-07) page 4, line 12 -page 5, line 8; figures 1-3	1-7,9
X	DE 38 03 317 A (OTIS ELEVATOR CO) 18 August 1988 (1988-08-18) the whole document	1-7,9
X	US 5 293 962 A (PELVILAIN JEAN-CLAUDE) 15 March 1994 (1994-03-15) the whole document	1-7,9
X	FR 2 364 321 A (METALLTUREN WERKE AUG DEUTSCHE) 7 April 1978 (1978-04-07) the whole document	1-6,8

Further documents are listed in the continuation of box C.  Patent family members are listed in annex.

Special categories of cited documents:

- \*A\* document defining the general state of the art which is not considered to be of particular relevance
- \*E\* earlier document but published on or after the international filing date
- \*I\* document which may throw doubts on priority claim(s) or which is cited to establish the publication date of another citation or other special reason (as specified)
- \*O\* document referring to an oral disclosure, use, exhibition or other means
- \*P\* document published prior to the international filing date but later than the priority date claimed
- \*T\* later document published after the international filing date or priority date and not in conflict with the application but cited to understand the principle or theory underlying the invention
- \*X\* document of particular relevance; the claimed invention cannot be considered novel or cannot be considered to involve an inventive step when the document is taken alone
- \*Y\* document of particular relevance; the claimed invention cannot be considered to involve an inventive step when the document is combined with one or more other such documents, such combination being obvious to a person skilled in the art.
- \* & \* document member of the same patent family

Date of the actual completion of the international search <b>27 March 2002</b>	Date of mailing of the international search report <b>05/04/2002</b>
---	---

Name and mailing address of the ISA European Patent Office, P.B. 5818 Patentlaan 2 NL - 2280 HV Rijswijk Tel. (+31-70) 340-2040, Tx. 31 651 epo nl, Fax: (+31-70) 340-3016	Authorized officer <b>Depoorter, F</b>
--	---

## INTERNATIONAL SEARCH REPORT

Information on patent family members

International Application No

PCT/TI 01/00418

Patent document cited in search report		Publication date	Patent family member(s)	Publication date
GB 2352754	A	07-02-2001	IT MI990503 U1 DE 20003267 U1	06-02-2001 03-08-2000
DE 3803317	A	18-08-1988	FR 2610311 A1 DE 3803317 A1	05-08-1988 18-08-1988
US 5293962	A	15-03-1994	AT 143340 T AU 658707 B2 AU 3039392 A BR 9205132 A CA 2084122 A1 CN 1076169 A ,B DE 59207250 D1 DK 548486 T3 EP 0548486 A1 ES 2094867 T3 FI 925632 A ,B, HK 1006447 A1 HU 212220 B JP 5253313 A MX 9207091 A1 NO 302132 B1 ZA 9209507 A	15-10-1996 27-04-1995 01-07-1993 29-06-1993 25-06-1993 15-09-1993 31-10-1996 20-01-1997 30-06-1993 01-02-1997 25-06-1993 26-02-1999 29-04-1996 05-10-1993 01-08-1993 26-01-1998 15-06-1993
FR 2364321	A	07-04-1978	DE 7628234 U1 AT 364956 B AT 645077 A BE 858580 A1 FR 2364321 A1 NL 7709835 A	23-12-1976 25-11-1981 15-04-1981 02-01-1978 07-04-1978 13-03-1978