

**(12) PATENT**  
**(19) AUSTRALIAN PATENT OFFICE**

**(11) Application No. AU 199873981 B2**  
**(10) Patent No. 722738**

(54) Title  
Flexible pipe with internal gasproof undulating metal tube

(51)<sup>6</sup> International Patent Classification(s)  
F 16L 009/06 F 16L 011/15  
F 16L 009/147

(21) Application No: 199873981 (22) Application Date: 1997.12.03

(87) WIPO No: WO98/25063

(30) Priority Data

(31) Number	(32) Date	(33) Country
96/14892	1996.12.04	FR

(43) Publication Date : 1998.06.29  
(43) Publication Journal Date : 1998.08.20  
(44) Accepted Journal Date : 2000.08.10

(71) Applicant(s)  
COFLEXIP

(72) Inventor(s)  
Patrice Joel Louis Jung; Anh Tuan Do

(74) Agent/Attorney  
DAVIES COLLISON CAVE, 1 Little Collins Street, MELBOURNE VIC 3000

(56) Related Art  
FR 1477478  
FR 1333402  
FR 2126616

OPI DATE 29/06/98 APPLN. ID 73981/98  
 AOJP DATE 20/08/98 PCT NUMBER PCT/FR97/02192



AU9873981

DEMA

PCT)

<p>(51) Classification internationale des brevets <sup>6</sup> :  <b>F16L 9/06, 9/147, 11/15</b></p>	<p><b>A1</b></p>	<p>(11) Numéro de publication internationale: <b>WO 98/25063</b>          (43) Date de publication internationale: 11 juin 1998 (11.06.98)</p>
<p>(21) Numéro de la demande internationale: PCT/FR97/02192          (22) Date de dépôt international: 3 décembre 1997 (03.12.97)          (30) Données relatives à la priorité:          96/14892 4 décembre 1996 (04.12.96) FR          (71) Déposant (pour tous les Etats désignés sauf US): COFLEXIP [FR/FR]; 23, avenue de Neuilly, F-75116 Paris (FR).          (72) Inventeurs; et          (75) Inventeurs/Déposants (US seulement): JUNG, Patrice, Joël, Louis [FR/FR]; Hameau de Gaveaumont, F-76940 La Mailleraye sur Seine (FR). DO, Anh, Tuan [FR/FR]; 26, rue de Chatou, F-95240 Corneilles en Parisis (FR).          (74) Mandataire: LEVY, David; S.A. Fédit-Loriot &amp; Autres, Conseils en Propriété Industrielle, 38, avenue Hoche, F-75008 Paris (FR).</p>	<p>(81) Etats désignés: AU, BR, CA, JP, NO, US, brevet européen (AT, BE, CH, DE, DK, ES, FI, FR, GB, GR, IE, IT, LU, MC, NL, PT, SE), brevet OAPI (BF, BJ, CF, CG, CI, CM, GA, GN, ML, MR, NE, SN, TD, TG).          Publiée  <i>Avec rapport de recherche internationale.</i></p>	

(54) Title: FLEXIBLE PIPE WITH INTERNAL GASPROOF UNDULATING METAL TUBE

(54) Titre: CONDUITE FLEXIBLE A TUBE INTERNE METALLIQUE ONDULE ETANCHE AUX GAZ

(57) Abstract

The invention concerns a flexible conduit comprising an internal gasproof undulating metal tube (1), the wall of which has helical undulations (8), the external surface of said internal tube having at least concave (10) and convex (11) rounded parts corresponding to the internal and external parts of the undulations respectively, and at least an arch (2) arranged around said internal metal tube and made up of at least a form wire (9) coiled in spires. The invention is characterised in that the arch (2) has an internal surface with helical undulation, comprising at least concave (16) and convex (15) rounded parts and the external surface of the internal metal tube is supported in its concave rounded part (10) by a convex part (15) of the arch (2) internal surface and in its convex rounded part (11) by a concave part (16) of the arch internal surface, said internal arch surface and said internal tube external surface matching in form, and the interstices (i) between the adjacent spires are small. The invention is particularly applicable to flexible conduits used in oil mining.

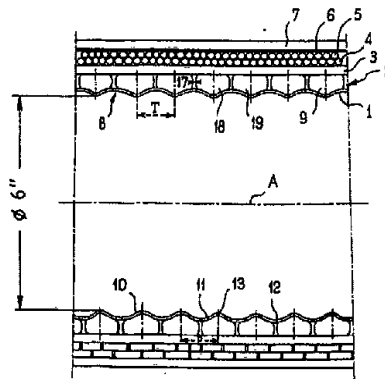

## ABSTRACT

Flexible pipe with internal Gasproof undulating metal tube.

10

The invention concerns a flexible conduit comprising an internal gasproof undulating metal tube (1), the wall of which has helical undulations (8), the external surface of said internal tube having at least  
15 concave (10) and convex (11) rounded parts corresponding to the internal and external parts of the undulations respectively, and at least an arch (2) arranged around said internal metal tube and made up of at least a form wire (9) coiled in spires. The invention is  
20 characterized in that the arch (2) has an internal surface with helical undulation, comprising at least concave (16) and convex (15) rounded parts and the external surface of the internal metal tube is supported in its concave rounded part (10) by a convex part (15) of the arch (2)  
25 internal surface and in its convex rounded part (11) by a concave part (16) of the arch internal surface, said internal arch surface and said internal tube external surface matching in form and the interstices (i) between the adjacent spires are small. The invention is  
30 particularly applicable to flexible conduits used in oil mining.

Figure 2.



**Flexible pipe with internal Gasproof undulating metal tube.**

5 The present invention relates to a long flexible pipe having an impermeable internal metal tube and more particularly to a flexible pipe including an internal corrugated metal tube which is, in particular, gas-impermeable.

10 The present invention also relates to a flexible pipe for transporting fluids at high pressure such as, for example, that used during operations for extracting crude oil from a subsea deposit. Such a pipe must, in particular, withstand the various forces to which it is subjected such as, for example, the internal and/or  
15 external pressures developed in and on the said flexible pipe, and must have a degree of flexibility along its longitudinal axis so that it can bend without risk of rupturing.

20 Under extreme service conditions such as, for example, in Arctic regions where very difficult climatic conditions prevail or else for transporting liquefied natural gas, it has been proposed to use either rigid steel pipes or flexible pipes which include an internal corrugated metal tube, as described in FR-A-2,458,022.

25 Other structures are also described in WO 96/17198 or GB-A-1,486,445.

The flexible pipe described in FR-A-2,458,022 comprises, from the inside to the outside:

- an internal corrugated metal tube;
- 30 - a metal casing wound around the internal corrugated tube and consisting of profiled wires, the winding pitch of which is in the opposite direction to the pitch of the corrugations of the said internal corrugated tube, this metal casing providing the bursting strength and called a pressure vault;



- two crossed armouring plies which provide the resistance to tensile loads and to the end cap effect due to the internal pressure of the pipe; and
- an external sleeve for protection and sealing.

5 In a variant, it is proposed to use as pressure vault a winding of a round wire which is housed in the troughs of the corrugations of the internal corrugated tube.

10 However, such a pipe has many drawbacks both with regard to the structure and from the behaviour standpoint.

15 In order to reinforce the internal corrugated tube, it is internally lined with an overlapping flat and welded spiralled metal tape or with a smooth tape, the space between the corrugations of the internal tube and the tape being optionally filled with a filling material. Consequently, this is a substantially more rigid structure which must be wound onto a large-diameter drum and which is fragile during the unwinding and winding  
20 operations in manufacture. When the corrugated tube is not reinforced with the aforementioned tape, then any momentary elongation of the pipe, as occurs when it is under tension, may generate a permanent elongation of the internal tube sometimes leading to rupture. Finally,  
25 whatever the recommended pressure vault, there is a risk of ovalizing the internal tube.

30 Whatever the circumstances, the flexible pipe of the prior art is unable to withstand the very high external pressures which develop at great depths, of the order of several thousands of metres, and/or the very high internal pressures developed in the pipe during exploitation operations.

The object of the present invention is to remedy the aforementioned drawbacks and to provide a flexible pipe which not only is capable of withstanding pressures



of several hundred bar exerted on the outside and/or on the inside of the pipe, but also of being able to be used at high temperatures and in an acid medium, i.e. capable of high performance in a corrosive medium, and of being suited for what those skilled in the art call "SOUR SERVICE".

5           According to the present invention there is provided flexible pipe of the type comprising an impermeable internal metal tube, the wall of which has helical corrugations, the outer surface of the said internal tube having at least concave rounded parts and convex rounded parts corresponding, respectively, to the internal part and external part of the corrugations, as well as at least one pressure vault placed around the said internal metal  
10 tube and consisting of at least one shaped metal wire wound in the form of turns, the pressure vault having a helical corrugated inner surface comprising at least concave rounded parts and convex rounded parts, the outer surface of the internal metal tube bearing in its concave rounded part on a convex part of the inner surface of the pressure vault and in its convex round part on a concave part of the inner surface of the pressure  
15 vault, the said inner surface of the vault and the said outer surface of the internal tube being in shape correspondence, characterized in that the ratio of the height of a corrugation to the pitch of the said corrugation is less than 1 and greater than 0.035, the gap between two consecutive turns being small but not zero.

          According to another characteristic, the flexible pipe is characterized in that the  
20 pressure vault is made from a wire wound around the said internal tube, each turn having a width approximately equal to the period of the corrugation of the internal tube.

          According to another characteristic, the flexible pipe is characterized in that the gap between two consecutive turns lies more or less vertically in line with a crest of the corrugation of the internal tube.



According to another characteristic, the flexible pipe is characterized in that the gap between two consecutive turns lies more or less vertically in line with a trough of the corrugation of the internal tube.

5           According to another characteristic, the flexible pipe is characterized in that the pressure vault is made from several wires wound around the internal tube.

          According to another characteristic, the flexible pipe is characterized in that the internal corrugated tube  
10 has corrugations, the radius of curvature (R) of a crest of which is greater than or equal to the radius of curvature (r) of a trough.

          According to another characteristic, the flexible pipe is characterized in that the internal corrugated tube  
15 is made of a metallic material having a low modulus of elasticity and being resistant to a corrosive medium.

          Other advantages and characteristics will become more apparent on reading the description of several embodiments according to the invention, as well as on  
20 examining the appended drawings in which:

- Figure 1 is a partial view in perspective of a flexible pipe according to the invention, certain parts of which are not complete;

- Figure 2 is a partial diagrammatic representation of a longitudinal section of the flexible pipe of  
25 Figure 1;

- Figure 3 is a partial enlarged view of part of Figure 2, the pipe being in flexure;

- Figure 4 is a partial view in cross-section of  
30 the internal corrugated tube illustrated in Figures 1 to 3;

- Figure 5 is a partial diagrammatic cross-sectional view of a vault/internal corrugated tube assembly according to a first embodiment of the invention;



- Figure 6 is a partial diagrammatic cross-sectional view of a vault/internal corrugated tube assembly according to another embodiment of the invention;

5 - Figure 7 is a partial diagrammatic cross-sectional view of a vault/internal corrugated tube assembly according to another embodiment of the invention;

10 - Figures 8 and 9 are, respectively, partial diagrammatic cross-sectional views of the vault/internal corrugated tube assemblies according to other embodiments of the invention.

The flexible pipe according to the invention, as illustrated in Figure 1, comprises, from the inside to the  
15 outside, an internal corrugated metal tube 1, a pressure vault 2, a sleeve 3, generally made of a thermoplastic having a high melting point, intended to prevent flattening under the high external pressures exerted on the said pipe and called by those skilled in the art an  
20 anticollapse sleeve, two crossed armouring plies 4 and 5, the armouring wires of one ply making an angle of less than 55° with respect to the longitudinal axis A of the pipe, an intermediate tape 6 and finally an external sealing sleeve 7. Apart from the internal tube 1 and the  
25 pressure vault 2, which form the subject of the present invention, all the other constituent components of the pipe are well known to those skilled in the art and will therefore not be described in detail, even if some of them, such as the tape 6, have formed the subject of  
30 recent improvements, in particular by the Applicant.

The internal corrugated metal tube 1, called hereafter a liner and illustrated in Figures 1 to 7, is a metal tube having corrugations 8 uniformly spaced over the entire length, the periodicity of the crests of the corrugations or of the troughs being defined, for the sake



of convenience, by a period T even though it may also be denoted by the term "pitch" which is used for the windings.

5 The period T or pitch of the corrugation (Figure 2) is identified, by convention, by the projection of the corrugation on the longitudinal axis A of the pipe, which is because the angle of the helix formed by the corrugation is close to  $90^\circ$  with respect to the longitudinal axis A of the pipe.

10 In a preferred embodiment of the invention, the liner 1 consists of an impermeable metal tube having a minimum thickness of 0.15 millimetres and a slight helical corrugation, i.e. one having a relatively small height h. The shape of the corrugation is defined so as to  
15 allow elongation under pressure without the risk of rupture, to allow winding for a defined diameter and to increase the flexibility. Tests carried out have shown that the radius of curvature R of a crest must be at least equal to the radius of curvature r of a trough (Figure 4).  
20 Preferably, the radius R must be between 1.5 and 10 times the radius r and better still between 3 and 5 times the radius of curvature r.

The pressure vault 2 consists, in a first embodiment illustrated in Figures 2 and 3, of a helical  
25 winding of a shaped wire 9 around the liner 1.

The corrugation 8 of the liner 1, seen from the outside, comprises concave parts 10 and convex parts 11, the period T being equal to the distance separating two successive crests 12 or two successive troughs 13 of the  
30 said corrugation 8.

The shaped wire 9 forming the pressure vault 2 comprises, on its inner surface 14, convex rounded parts 15 and concave parts 16. The concave parts 10 of the liner 1 bear on the convex parts 15 of the shaped wire  
and more generally the concave parts of the liner 1 bear



on the convex parts of the inner surface of the pressure vault 2, taken in its entirety and, when the flexible pipe is straight, as illustrated in Figure 2.

The shaped wire 9 is wound helically, forming  
5 turns which are spaced apart, it being possible for the clearance 17 between two consecutive turns 18, 19 to be zero when the pipe is put into flexure. In the case of Figure 3, in which the shaped wire 9 is rounded on the lateral edges 50, the clearance 17 does not correspond to  
10 the gap  $i$ , whereas in Figures 5 to 7 the clearance is equal to the gap  $i$  since the lateral edges of the wire are straight and perpendicular to the longitudinal axis A. Gap  $i$  could be understood to mean the space separating two consecutive turns which is taken on the inner surface of  
15 the pressure vault 2.

The correspondence between the outer surface of the liner 1 with the inner surface of the pressure vault results in bearing parts being defined which have more or less identical geometrical characteristics. Thus, the  
20 convex parts 15 of the inner surface of the pressure vault have a radius of curvature which is equal to the radius of curvature  $r$  of the concave parts 10 of the outer surface of the liner 1.

In the case of Figures 2 and 3, the winding pitch  
25  $P$  of the shaped wire 9 is equal to the period  $T$  of the corrugation 8 of the liner 1, and the clearance 17 between two consecutive turns 18, 19 lies opposite the crest or top 12 of the corrugation 8.

As may be seen in Figure 3, the turns 18, 19 are  
30 not completely touching on the outer fibre (upper part of the figure), whereas they are touching on the inner fibre (lower part of the figure) because of the fact that the flexible pipe is in flexure.

The shape correspondence between the outer surface of the liner 1 and the inner surface of the



pressure vault 2, and because they bear on each other over a large proportion of the surface and because of the small clearance between turns, means that, when the pipe is put into flexure, the neutral fibre, which is normally  
5 in coincidence with the longitudinal axis A, can move slightly towards the inner-fibre surface of the liner. Thus, the risk of localized buckling in the concave and/or convex inner-fibre parts of the liner 1 is avoided or greatly reduced. Consequently, the clearance 17 between  
10 the consecutive turns which existed in the inner fibre disappears and the said turns are touching whereas, in the outer fibre, the clearance 17 increases and the liner 1 is therefore put into tension, the winding pitch and the period of the corrugation increasing in turn. The convex  
15 parts 11 of the liner 1 partially separate from the inner surface of the pressure vault and work in the manner of a membrane when a pressurized fluid flows in the flexible pipe.

In a preferred embodiment of the invention, the  
20 ratio of the height  $h$  of the corrugation 8 to the thickness  $e$  of the liner 1 is between 1 and 30 and preferably between 1.5 and 20 (Figure 4). In addition, the ratio  $h/T$  is less than 1 and greater than 0.05 and preferably lies between 0.15 and 0.35. The clearance 17 between  
25 consecutive turns is small and less than  $0.15 l$ ,  $l$  being the width of a turn.

In order to prevent the liner 1 from deforming due to the effect of the internal pressure of the fluid flowing in the flexible pipe and to ensure contact between  
30 the liner 1 and the pressure vault 2 over the entire circumference of the liner 1, it is preferable to use materials having a low modulus of elasticity such as certain steels, titanium, aluminium or aluminium alloys. The choice of material must take account of the resistance to the corrosive medium.



Since the liner 1 is gas-impermeable and resistant to a corrosive medium, it is no longer necessary to take the criterion of resistance to a corrosive medium into account when choosing the material constituting, in particular, the pressure vault 2. For the latter, it is sufficient to choose a material having high mechanical properties and able to be easily formable. Among the possible materials, mention may be made of a steel of the XC 35 type according to the usual standards. This is also true for the tension armouring; consequently, the weight and cost of the flexible pipe may be considerably reduced.

Finally, because the metal liner 1 is gas-impermeable, the anticollapse sleeve 3 may be made of a lower-performance material than that normally used in flexible pipes, the sole criterion to be taken into consideration being the temperature withstand capability.

Figure 5 illustrates another embodiment in which the liner 1 is identical to that illustrated in Figures 2 to 4, but its pressure vault 2 is made with a shaped wire 20, each turn of which has two concave parts 21a and 21b lying on each side of a convex part 22. Consequently, the concave parts 21a and 21b of two consecutive turns match the convex part 11 of the liner 1, the clearance 17 existing between the two consecutive turns being equal to the gap  $i$  and lying opposite the crest or top 12 of the convex part 11, this being because the lateral edges 23 of the shaped wire 20 are straight and perpendicular to the longitudinal axis A. In addition, the width  $l$  of each turn is approximately equal to the period  $T$  of the corrugation.

Figure 6 illustrates an embodiment which is similar to that in Figure 5, except that each turn comprises a concave part 24 which matches the shape of the corresponding convex part 11 of the liner 1, the said concave part 24 being surrounded by two convex parts



25a and 25b. In this case, the gap  $i$  lies opposite the trough of the corrugation.

In another embodiment illustrated in Figure 7, the pressure vault 2 consists of two alternate windings of shaped wires 26 and 27 which are in such a way that two consecutive turns 26' and 27' are symmetrical with respect to the junction planes 28 and 28'. The junction plane 28' passes through the bottom of a trough of the corrugation 8 while the junction plane 28 passes through the top of the crest of the said corrugation, the objective being that two consecutive turns 26', 27' of the two alternate windings form something akin to the single turn in the Figures 5 or 6.

Figure 8 illustrates another embodiment in which the liner 1 is identical to the previous embodiments, while the pressure vault 2 consists of a winding of two differently shaped wires. The first shaped wire 29 has a part 30, of concave shape, which matches the convex part of the liner 1 and extends between two consecutive inflection points 31, 32 of a corrugation. The second shaped wire 33 has a part 34, of convex shape, which matches the concave part of the liner 1 and extends between two consecutive inflection points; the combination of the shaped wires 29 and 23 may be likened to a single turn which would have a width equal to the period  $T$  of the corrugation, apart from the gaps. In this case, the gaps lie opposite the mid-part 35 of the corrugation, lying between the convex and concave parts of the liner 1.

Figure 9 illustrates another embodiment in which the pressure vault consists of a winding of two different wires 36, 37.

The shaped wire 36 is a round wire, the radius of which is approximately equal to the radius  $r$ , and is housed in the troughs of the corrugation 8.



The shaped wire 37 is more complex and is adapted, in its central part 38, so as to match the shape of the convex part of the corrugation 8, the junction zone between the two shaped wires 36 and 37 lying more or less vertically in line with the trough of the corrugation. Of course, the lateral parts 39 of the shaped wire 37 must correspond to the round wire 36 in order to achieve a certain uniformity.

In all the embodiments, the consecutive or adjacent turns may have, on their external surfaces, recesses 40 with which connection devices, such as clips 41, engage in order to connect two consecutive or adjacent turns together, thus limiting excessive elongation of the pressure vault (Figure 5).

In order to make it easier to extrude the anticollapse sleeve 3 onto the pressure vault 2, the latter has a cylindrical outer surface 42 when the pipe is straight, as illustrated in the figures.

The cylindrical outer surface 42 forms a good bearing surface for the anticollapse sleeve 3.

Moreover, it should be noted that, according to the invention, each armouring 4, 5 surrounding the anticollapse sleeve 3 consists of the helical winding of at least one ply of wire wound at a setting angle of less than  $55^\circ$ . Preferably, the flexible pipe comprises two plies of wound wires 4, 5 with the same setting angle but in opposite directions, the said plies themselves being surrounded by a sleeve 7 for protection and sealing, with or without a tape 6 being interposed.

The pressure vault 2 may be wound using a pair of identical wires or using two pairs of shaped wires, each of the latter pairs comprising a shaped wire of a given cross-section and another shaped wire of a cross-section which corresponds to the given cross-section.



A preferred process for forming the pressure vault 2/liner 1 assembly consists:

- in unreeling, from a feed roll, a long thin tape;
- in passing the said tape through forming means in order gradually to give it the shape of a hollow cylinder;
- 5       - in continuously producing, along a generatrix or in a helix, a weld between the free edges in order to form a cylindrical impermeable hollow tube;
- in passing the impermeable hollow tube through corrugating means consisting, for example, of press rollers and, optionally, of a rotating core having a helical corrugated surface; and
- 10       - in winding one or more shaped wires around the corrugated internal tube.

Such an assembly may be wound with a long length onto a storage reel, awaiting the completion of the flexible pipe.

Of course, other manufacturing processes may be used. Among these, mention may be made of that consisting in butt-joining short lengths of hollow cylinders and then in  
15 forming the necessary corrugations on the said hollow tube thus obtained before winding the shaped wire or wires constituting the pressure vault.

The reference to any prior art in this specification is not, and should not be taken as, an acknowledgment or any form of suggestion that prior art forms part of the common general knowledge in Australia.

20 Throughout this specification and the claims which follow, unless the context requires otherwise, the word "comprise", and variations such as "comprises" and "comprising", will be understood to imply the inclusion of a stated integer or step or group of integers or steps but not the exclusion of any other integer or step or group of integers or steps.

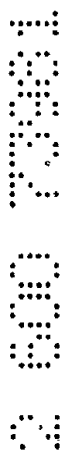

THE CLAIMS DEFINING THE INVENTION ARE AS FOLLOWS:

1. Flexible pipe of the type comprising an impermeable internal metal tube, the wall of which has helical corrugations, the outer surface of the said internal tube having at least  
5 concave rounded parts and convex rounded parts corresponding, respectively, to the internal part and external part of the corrugations, as well as at least one pressure vault placed around the said internal metal tube and consisting of at least one shaped metal wire wound in the form of turns, the pressure vault having a helical corrugated inner surface comprising at least concave rounded parts and convex rounded parts, the outer surface of  
10 the internal metal tube bearing in its concave rounded part on a convex part of the inner surface of the pressure vault and in its convex round part on a concave part of the inner surface of the pressure vault, the said inner surface of the vault and the said outer surface of the internal tube being in shape correspondence, characterized in that the ratio of the height of a corrugation to the pitch of the said corrugation is less than 1 and greater than  
15 0.035, the gap between two consecutive turns being small but not zero.

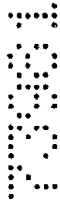

2. Pipe according claim 1, characterized in that the height of the corrugation is relatively small, the ratio of the said height to the thickness of the metal internal tube is between 1 and 30 and preferably between 1.5 and 20.

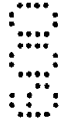

3. Pipe according to Claim 1 or 2, characterized in that the convex parts of the internal tube have a radius of curvature which is at least equal to the radius of curvature of the concave parts of the said internal tube, the ratio of the radii of curvature being between 1 and 10 and preferably between 1.5 and 5.



4. Pipe according to claim 1 or 2, characterized in that the pressure vault consists of a winding of several shaped wires, one of the said shaped wires comprising only concave parts and another shaped wire comprising only convex parts.

5. Pipe according to any one of claims 1 to 4, characterized in that the gaps between consecutive turns lie opposite the crest of the corrugation of the internal metal tube.



6. Pipe according to any one of claims 1 to 4, characterized in that the gaps between consecutive turns lie more or less in the middle of the trough of the corrugation of the internal metal tube.

5 7. Pipe according to any one of claims 1 to 4, characterized in that the gaps between consecutive turns lie opposite the mid-part of the corrugation, lying between the convex part and concave part, respectively, of the said internal tube.

8. Pipe according to claim 1, 2, 5, 6 or 7, characterized in that the cross-section of the  
10 said at least one shaped wire in a longitudinal plane has a maximum width parallel to the axis of the flexible pipe which is equal to or slightly less than the period of the corrugation of the said internal tube, the difference between the said width and the period of the corrugation corresponding to the clearance between two consecutive turns of the said shaped wire.

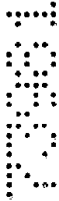

15 9. Pipe according to any one of claims 1 to 7, characterized in that the cross-section of the said at least one shaped wire in a longitudinal plane has a maximum width parallel to the axis of the flexible pipe which is equal to or slightly less than the half-period of the  
20 corrugation of the said internal tube, the difference between the said width and the half-period of the corrugation corresponding to the clearance between two consecutive turns of the said at least one shaped wire.



10. Pipe according to any one of claims 1 to 9, characterized in that the cross-section of  
25 the said at least one shaped wire has two lateral edges which are straight and perpendicular to the axis of the flexible pipe.



11. Pipe according to any one of claims 1 to 9, characterized in that the cross-section of the said at least one shaped wire has two slightly convex lateral edges.

30 12. Pipe according to any one of claims 1 to 11, characterized in that the metal internal tube is gas-impermeable.



13. Pipe according to any one of claims 1 to 12, characterized in that the metal internal tube has a small thickness at least equal to 0.15 mm.
14. Pipe according to any one of claims 1 to 13, characterized in that the internal metal tube is resistant to a corrosive medium.
15. Pipe according to any one of claims 1 to 14, characterized in that the pressure vault is made of steel having a high mechanical strength.
16. Pipe according to any one of claims 1 to 15, characterized in that the corrugations of the internal metal tube are generated when winding the shaped wire forming the pressure vault.
17. Pipe according to claim 1, characterized in that it furthermore includes a plastic sleeve placed around the pressure vault and in that the outer surface of the pressure vault has an approximately cylindrical general shape when the pipe is straight so as to form a bearing surface for the said plastic sleeve.
18. Pipe according to claim 1 or 2, characterized in that it furthermore includes, on the outside of the plastic sleeve surrounding the said pressure vault, and armoring resistant to tensile loads, consisting of the helical winding of at least one ply of wire wound at a setting angle of less than 55°.
19. Pipe according to claim 18, characterized in that the armoring resistant to tensile loads comprises two plies of wires wound at the same setting angle but in opposite directions and in that the flexible pipe furthermore includes a protective sleeve on the outside of the said armoring plies.
20. Pipe according to one of claims 18 and 19, characterized in that the tension armoring is made of a material having a high modulus of elasticity and a high mechanical strength.



21. Pipe according to one of the preceding claims, characterized in that the shaped wires forming the turns of the pressure vault each have a recess and in that it furthermore comprises connecting devices capable of connecting two consecutive turns together.

5 22. Flexible pipe substantially as hereinbefore described with reference to the accompanying drawings.

DATED this 31<sup>st</sup> day of May, 2000

10 **Coflexip**

By its Patent Attorneys

**DAVIES COLLISON CAVE**

7  
8  
9

8  
9

04



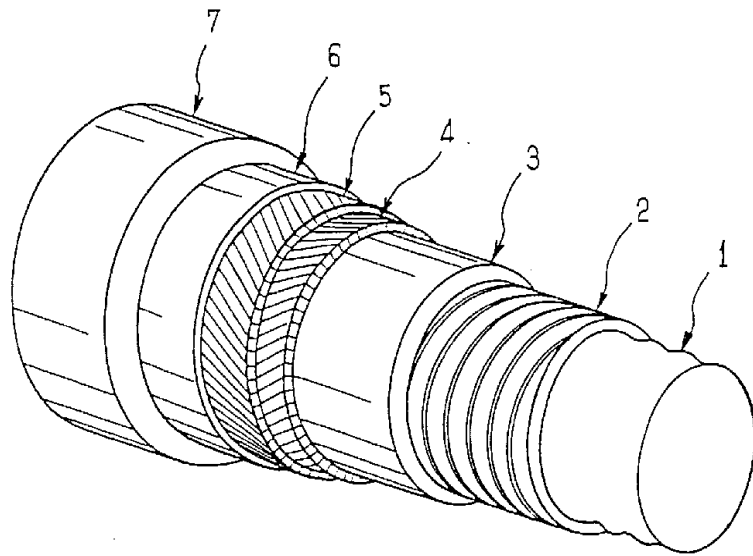

FIG.1

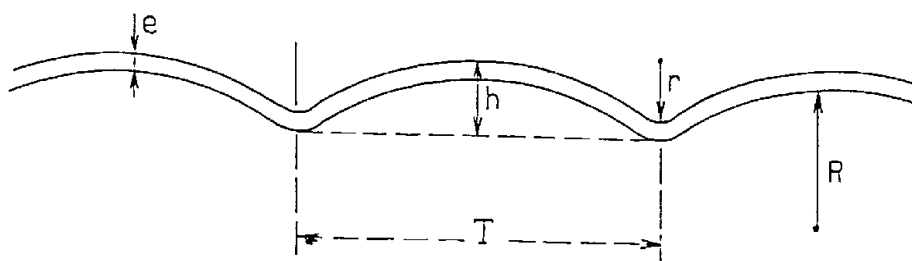

FIG. 4

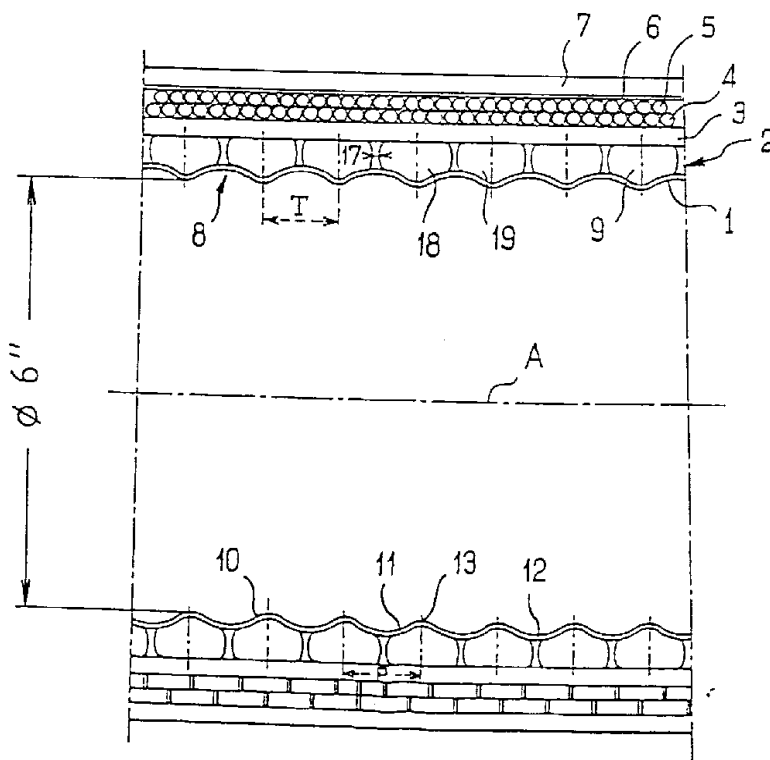

FIG. 2

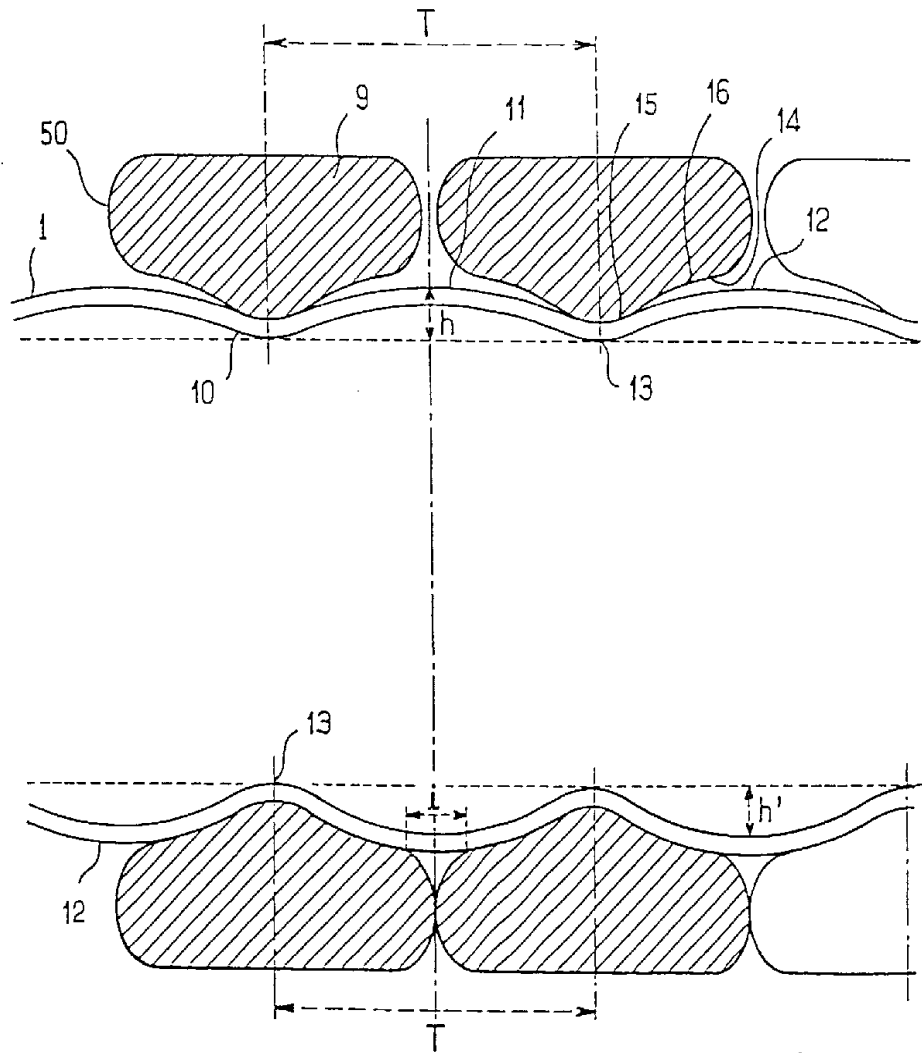

FIG. 3

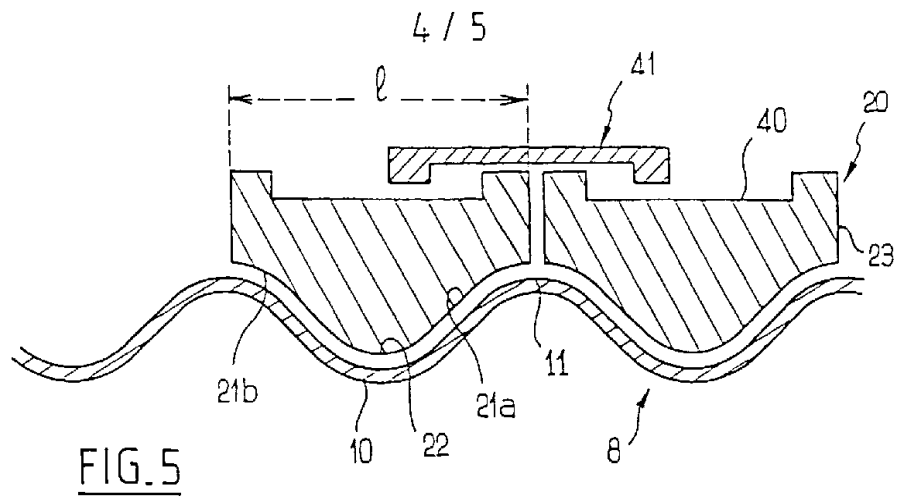

FIG. 5

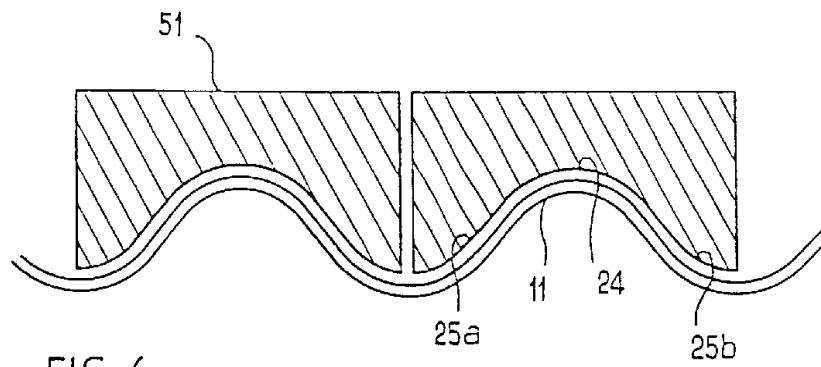

FIG. 6

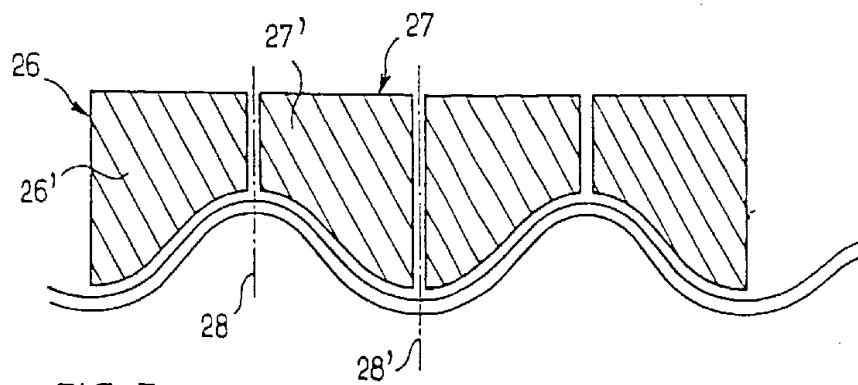

FIG. 7

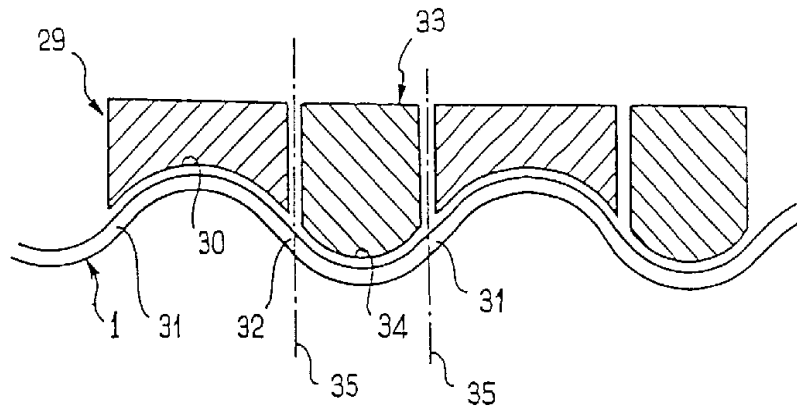

FIG. 8

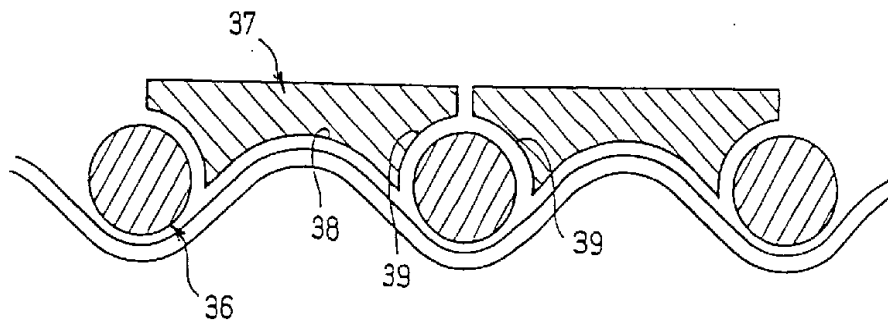

FIG. 9