

CORRECTED VERSION

(19) World Intellectual Property Organization
International Bureau



(10) International Publication Number
WO 2017/165169 A9

(43) International Publication Date
28 September 2017 (28.09.2017)

- (51) International Patent Classification:
H01B 11/18 (2006.01) H01B 11/22 (2006.01)
- (21) International Application Number:
PCT/US2017/022507
- (22) International Filing Date:
15 March 2017 (15.03.2017)
- (25) Filing Language: English
- (26) Publication Language: English
- (30) Priority Data:
62/312,315 23 March 2016 (23.03.2016) US
- (71) Applicant: COMMSCOPE TECHNOLOGIES LLC
[US/US]; 1100 CommScope Place SE, Hickory, North Carolina 28602 (US).
- (72) Inventor: ISLAM, Nahid; 318 Cromwell Court, Westmont, Illinois 60559 (US).
- (74) Agent: MYERS BIGEL, P.A.; P.O.Box 37428, Raleigh, North Carolina 27627 (US).
- (81) Designated States (unless otherwise indicated, for every kind of national protection available): AE, AG, AL, AM, AO, AT, AU, AZ, BA, BB, BG, BH, BN, BR, BW, BY, BZ,

CA, CH, CL, CN, CO, CR, CU, CZ, DE, DJ, DK, DM, DO, DZ, EC, EE, EG, ES, FI, GB, GD, GE, GH, GM, GT, HN, HR, HU, ID, IL, IN, IR, IS, JP, KE, KG, KH, KN, KP, KR, KW, KZ, LA, LC, LK, LR, LS, LU, LY, MA, MD, ME, MG, MK, MN, MW, MX, MY, MZ, NA, NG, NI, NO, NZ, OM, PA, PE, PG, PH, PL, PT, QA, RO, RS, RU, RW, SA, SC, SD, SE, SG, SK, SL, SM, ST, SV, SY, TH, TJ, TM, TN, TR, TT, TZ, UA, UG, US, UZ, VC, VN, ZA, ZM, ZW.

(84) Designated States (unless otherwise indicated, for every kind of regional protection available): ARIPO (BW, GH, GM, KE, LR, LS, MW, MZ, NA, RW, SD, SL, ST, SZ, TZ, UG, ZM, ZW), Eurasian (AM, AZ, BY, KG, KZ, RU, TJ, TM), European (AL, AT, BE, BG, CH, CY, CZ, DE, DK, EE, ES, FI, FR, GB, GR, HR, HU, IE, IS, IT, LT, LU, LV, MC, MK, MT, NL, NO, PL, PT, RO, RS, SE, SI, SK, SM, TR), OAPI (BF, BJ, CF, CG, CI, CM, GA, GN, GQ, GW, KM, ML, MR, NE, SN, TD, TG).

Published:
— with international search report (Art. 21(3))
— with information concerning authorization of rectification of an obvious mistake under Rule 91.3 (b) (Rule 48.2(i))

(48) Date of publication of this corrected version:
02 August 2018 (02.08.2018)

(54) Title: ASSEMBLY FOR DISTRIBUTING TRUNK CABLE TO FURCATED CABLE

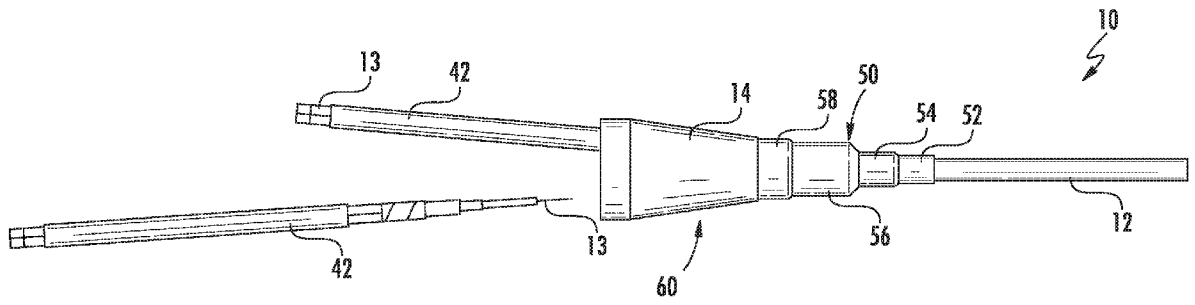

FIG. 1

(57) Abstract: A cable distribution assembly includes: a housing having a first side and a second side, wherein a plurality of bores extend through the housing from the first side to the second side; a plurality of furcation tubes inserted into the bores at the second side of the housing; a trunk cable comprising a jacket and a plurality of optical fibers, wherein one or more of the optical fibers are threaded through the bores and into the furcation tubes; a spacer adjacent the first side of the housing and the cable jacket, the spacer creating space in which the optical fibers are routed from the trunk cable to the bores at the first side of the housing; and a cover that covers the spacer and at least partially covers the trunk cable and the first side of the housing.



WO 2017/165169 A9

(15) Information about Correction:

see Notice of 02 August 2018 (02.08.2018)

ASSEMBLY FOR DISTRIBUTING TRUNK CABLE TO FURCATED CABLE**Related Application**

[0001] The present application claims priority from and the benefit of U.S. Provisional Patent Application No. 62/312, 315, filed March 23, 2016, the disclosure of which is hereby incorporated herein in its entirety.

Field of the Invention

[0002] The present invention relates generally to power and signal distribution, and more particularly to distribution from trunk cables to furcated cables.

Background

[0003] Latest developments in technology for delivering power and data in wireless infrastructure use hybrid cables, wherein the term "hybrid cable" refers to a cable that includes both power conductors and one or more fiber optic cords or cables. An exemplary hybrid cable is the HFF cable, available from CommScope, Inc. (Joliet, Illinois). Unlike RF-based systems, a single hybrid trunk cable can be used to power multiple sectors, thereby eliminating multiple runs of RF cable. However, in order to use a single hybrid trunk cable, at some point the trunk cable must transition to jumper cables. Typically, these are distributed inside an enclosure that transitions the trunk conductor gauge to the jumper conductor gauge and connects the optical

fibers in the trunk to the optical fibers in the jumper cables. Currently, transitions are achieved by making connections inside the enclosure, requiring it to be opened, cables to be fed/mated to the enclosure, and power and fiber connections to be made, all in the field (e.g., on the top of cell sites near a remote radio unit (RRU)). This practice can create many issues for installers, including time, safety, connection errors (such as loose power connections and/or poor fiber cleaning), and more opportunity for connector damage.

Summary

[0004] As a first aspect, embodiments of the invention are directed to a cable distribution assembly, comprising: a housing having a first side and a second side, wherein a plurality of bores extend through the housing from the first side to the second side; a plurality of furcation tubes inserted into the bores at the second side of the housing; a trunk cable comprising a jacket and a plurality of optical fibers, wherein one or more of the optical fibers are threaded through the bores and into the furcation tubes; a spacer adjacent the first side of the housing and the cable jacket, the spacer creating space in which the optical fibers are routed from the trunk cable to the bores at the first side of the housing; and a cover that covers the spacer and at least partially covers the trunk cable and the first side of the housing.

[0005] As a second aspect, embodiments of the invention are directed to a cable distribution assembly, comprising: a housing having a first side and a second side, wherein a plurality of bores extend through the housing from the first side to the second side; a plurality of armored furcation tubes inserted into the bores at the second side of the housing; a trunk cable comprising a jacket and a plurality of optical fibers, wherein one or more of the optical fibers are threaded through the bores and into the furcation tubes; a spacer adjacent the first side of the housing and the cable jacket, the spacer creating space in which the optical fibers are routed from the trunk cable to the bores at the first side of the housing; and a cover that covers the spacer and at least partially covers the trunk cable and the first side of the housing, wherein in the cover comprises a ferrule and a heat-shrink tube overlying the ferrule.

[0006] As a third aspect, embodiments of the invention are directed to a method of forming a cable distribution, comprising the steps of:

- (a) inserting a plurality of optical fibers of a trunk cable through a spacer;
- (b) inserting the plurality of optical fibers into bores in a first side of a housing;

- (b) inserting the plurality of optical fibers into a plurality of furcation tubes;
- (c) inserting the plurality of furcation tubes into the bores in a second side of the housing;
- (e) positioning the spacer adjacent the first side of the housing; and
- (f) applying a cover that at least partially covers the cable and the housing and covers the spacer.

Brief Description of the Figures

[0007] FIG. 1 is a side view of an assembly for distributing trunk cable to furcated cable according to embodiments of the invention, with a fiber optic trunk cable entering one end of the assembly and two furcated cables (one of which is exploded in the illustrated view) exiting the other end of the assembly.

[0008] FIG. 2 is a perspective view of the housing of the assembly of FIG. 1.

[0009] FIG. 3 is a side section view of the housing of FIG. 2.

[0010] FIG. 4 is an enlarged partial perspective view of the neck end of the housing of FIG. 2.

[0011] FIG. 5 is an end perspective view of the wide end of the housing of FIG. 2.

[0012] FIG. 6 is a perspective view of the spacer of the assembly of FIG. 1.

[0013] FIG. 7 is a perspective view of the crimp ferrule of the assembly of FIG. 1.

[0014] FIG. 8 is a perspective view of the heat shrink tube of the assembly of FIG. 1.

[0015] FIG. 9 is a side view of the housing of FIG. 2 and the spacer of FIG. 6 during assembly of the assembly of FIG. 1 with a fiber optic trunk cable.

[0016] FIG. 10 is a side section view of the housing and spacer of FIG. 9.

[0017] FIG. 11 is a side view of the housing of FIG. 2 and the crimp ferrule of FIG. 7 during assembly of the assembly of FIG. 1.

Detailed Description

[0018] The present invention is described with reference to the accompanying drawings, in which certain embodiments of the invention are shown. This invention may, however, be embodied in many different forms and should not be construed as limited to the embodiments that are pictured and described herein; rather, these embodiments are provided so that this disclosure will be thorough and complete, and will fully convey the scope of the invention to

those skilled in the art. It will also be appreciated that the embodiments disclosed herein can be combined in any way and/or combination to provide many additional embodiments.

[0019] Unless otherwise defined, all technical and scientific terms that are used in this disclosure have the same meaning as commonly understood by one of ordinary skill in the art to which this invention belongs. The terminology used in the below description is for the purpose of describing particular embodiments only and is not intended to be limiting of the invention. As used in this disclosure, the singular forms "a", "an" and "the" are intended to include the plural forms as well, unless the context clearly indicates otherwise. It will also be understood that when an element (e.g., an assembly, circuit, cable, housing, etc.) is referred to as being "connected" or "coupled" to another element, it can be directly connected or coupled to the other element or intervening elements may be present. In contrast, when an element is referred to as being "directly connected" or "directly coupled" to another element, there are no intervening elements present.

[0020] Referring now to the drawings, a transition assembly, designated broadly at 10, is shown in FIG. 1. The transition assembly 10 includes a trunk cable 12, typically a fiber optic cable, that enters one end of a conical transition housing 14, and optical fibers 13 housed within furcation tubes 42 that exit the opposite end of the housing 14. These components are described in greater detail below.

[0021] Referring now to FIGS. 2-5, the housing 14 is generally conical in shape. At its narrow end the housing 14 includes a threaded or ribbed neck 16 with a plurality of bores 18. Each of the bores 18 extends through the length of the housing 14 (see FIGS. 3-5). The housing 14 also includes a shoulder 20 adjacent the neck 16 that is slightly larger than the neck 16. The housing 14 is typically formed of a polymeric material, such as polycarbonate or PBT (filled or unfilled), or a metallic material such as aluminum, and may be fashioned via molding or machining.

[0022] Referring now to FIG. 6, a spacer 22 is positioned adjacent the free end of the neck 16. The spacer 22 has a circular base 24, a circular through boss 26 that extends from one side of the base 24, and four legs 28 that extend from the opposite side of the base 24 that form gaps 30. The spacer 22 is typically formed of a polymeric material, such as polycarbonate or PBT (filled or unfilled), or a metallic material such as aluminum.

[0023] Referring now to FIG. 7, a crimp ferrule 32 includes a narrow ring 34 and a wide ring 36. A heat shrink tube 50 (see FIG. 8) is generally cylindrical, but has a gradually stepped profile,

such that it has a narrow end 52, two intermediate sections 54, 56, and a wide end 58. The heat shrink tube 50 is typically formed of a heat-shrinkable material, such as a polyolefin (optionally with an adhesive).

[0024] During construction of the assembly 10, the crimp ferrule 32 and heat shrink tube 58 are slipped onto the trunk cable 12. The optical fibers 13 of the cable 12 are routed through the boss 26 and gaps 30 of the spacer 22 and into the bores 18 of the housing 14. One or more optical fibers 13 from the trunk cable 12 are then threaded into each furcation tube 42. The furcation tubes 42 are then inserted into the ends of the bores 18 adjacent the wider end of the housing 14 such that the optical fibers 13 "pass through" the housing 14 as they are routed from the cable 12 to the furcation tubes 42 (see FIG. 10). The housing 14 is positioned adjacent the spacer 22 such that the ends of the legs 28 of the spacer 22 abut the free end of the neck 16 of the housing 14 (see FIG. 9). The legs 28 of the spacer 22 are of sufficient length that the optical fibers 13 can be routed into the bores 18 of the housing 14 without undue bending. In some embodiments, the legs 28 provide an axial gap of at least 15-20 mm to protect the optical fibers, although this may vary; ideally the optical fibers undergo a bend of less than about 30 degrees.

[0025] As shown in FIG. 11, the crimp ferrule 32 is then slipped over the spacer 22, with the narrow ring 34 surrounding the end of the jacket of the cable 12 and the wide ring 36 fitting over the spacer 22 and the neck 16 of the housing 14. The crimp ferrule 32 can then be secured in place via crimping of the narrow ring 34 and the wide ring 36 to their respective underlying components. The crimp ferrule 32 can provide strain relief for the optical fibers 13.

[0026] Referring now to FIG. 1, the heat shrink tube 50 can then be slipped over the crimp ferrule 32 and the shoulder 20 of the housing 12, with the narrow end 52 overlying a portion of the jacket of the cable 12, the intermediate sections 54, 56 overlying the narrow and wide rings 34, 36 of the crimp ferrule 32, and the wide end 58 overlying the shoulder 20 of the housing 14. Once in place, the heat shrink tube 50 is heated; the heating process shrinks the heat shrink tube 50 over these underlying structures. Thus, together the heat shrink tube 50 and the crimp ferrule 32 provide a protective cover 60 for the assembly 10.

[0027] Those of skill in this art will appreciate that the assembly 10 may take alternative forms. For example, the housing 14 may be shaped differently (e.g., it may be cylindrical or rectangular), and/or may have different numbers of bores. The housing 14 may be formed by molding as described above, or may be overmolded as a monolithic structure over the cable 12

and furcation tubes 42. The bores 18 may be routed between to and/or from different sides of the housing 14 rather than to and from the ends. The crimp ferrule 32 and/or the heat shrink tube 58 may be configured differently or omitted from the cover 60. The furcation tubes 42 may be armored. In some embodiments, the cable 12 may be a hybrid power/fiber cable rather than a fiber optic cable. Other variations may also be suitable.

[0028] The foregoing is illustrative of the present invention and is not to be construed as limiting thereof. Although exemplary embodiments of this invention have been described, those skilled in the art will readily appreciate that many modifications are possible in the exemplary embodiments without materially departing from the novel teachings and advantages of this invention. Accordingly, all such modifications are intended to be included within the scope of this invention as defined in the claims. The invention is defined by the following claims, with equivalents of the claims to be included therein.

That Which is Claimed is:

1. A cable distribution assembly, comprising:
 - a housing having a first side and a second side, wherein a plurality of bores extend through the housing from the first side to the second side;
 - a plurality of furcation tubes inserted into the bores at the second side of the housing;
 - a trunk cable comprising a jacket and a plurality of optical fibers, wherein one or more of the optical fibers are threaded through the bores and into the furcation tubes;
 - a spacer adjacent the first side of the housing and the cable jacket, the spacer creating space in which the optical fibers are routed from the trunk cable to the bores at the first side of the housing; and
 - a cover that covers the spacer and at least partially covers the trunk cable and the first side of the housing.
2. The assembly defined in Claim 1, wherein the cover comprises a ferrule and a heat-shrink sheath that overlies the ferrule.
3. The assembly defined in Claim 2, wherein the ferrule is a crimp ferrule.
4. The assembly defined in Claim 1, wherein the housing is generally conical, with a narrower first side and a wider second side.
5. The assembly defined in Claim 3, wherein the first side of the housing includes a neck, and wherein the cover overlies the neck.
6. The assembly defined in Claim 1, wherein the housing comprises a monolithic structure with the bores formed therein.
7. The assembly defined in Claim 1, wherein the furcation tubes are armored furcation tubes.

8. The assembly defined in Claim 1, wherein the trunk cable is a fiber optic cable.
9. The assembly defined in Claim 1, wherein the spacer includes a plurality of legs that contact the first side of the housing and a boss that receives optical fibers from the trunk cable as the optical fibers are routed into the housing.
10. The assembly defined in Claim 9, wherein the spacer creates an axial gap of at least 15 mm for optical fiber routing.
11. A cable distribution assembly, comprising:
 - a housing having a first side and a second side, wherein a plurality of bores extend through the housing from the first side to the second side;
 - a plurality of armored furcation tubes inserted into the bores at the second side of the housing;
 - a trunk cable comprising a jacket and a plurality of optical fibers, wherein one or more of the optical fibers are threaded through the bores and into the furcation tubes;
 - a spacer adjacent the first side of the housing and the cable jacket, the spacer creating space in which the optical fibers are routed from the trunk cable to the bores at the first side of the housing; and
 - a cover that covers the spacer and at least partially covers the trunk cable and the first side of the housing, wherein the cover comprises a ferrule and a heat-shrink tube overlying the ferrule.
12. The assembly defined in Claim 11, wherein the ferrule is a crimp ferrule.
13. The assembly defined in Claim 11, wherein the housing is generally conical, with a narrower first side and a wider second side.
14. The assembly defined in Claim 13, wherein the first side of the housing includes a neck, and wherein the cover overlies the neck.

15. The assembly defined in Claim 11, wherein the housing comprises a monolithic structure with the bores formed therein.
16. The assembly defined in Claim 11, wherein the trunk cable is a fiber optic cable.
17. The assembly defined in Claim 11, wherein the spacer includes a plurality of legs that contact the first side of the housing and a boss that receives optical fibers from the trunk cable as the optical fibers are routed into the housing.
18. The assembly defined in Claim 17, wherein the spacer creates an axial gap of at least 15 mm for optical fiber routing.
19. A method of forming a cable distribution, comprising the steps of:
 - (a) inserting a plurality of optical fibers of a trunk cable through a spacer;
 - (b) inserting the plurality of optical fibers into bores in a first side of a housing;
 - (b) inserting the plurality of optical fibers into a plurality of furcation tubes;
 - (c) inserting the plurality of furcation tubes into the bores in a second side of the housing;
 - (e) positioning the spacer adjacent the first side of the housing; and
 - (f) applying a cover that at least partially covers the cable and the housing and covers the spacer.
20. The method defined in Claim 19, wherein the cover comprises a crimp ferrule and a heat-shrink tube.

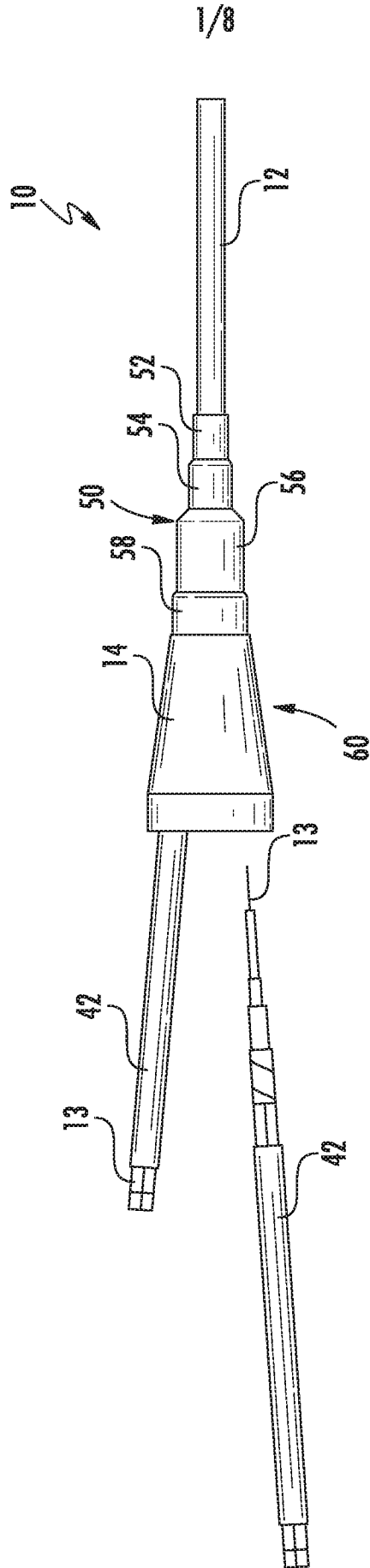

FIG. 1

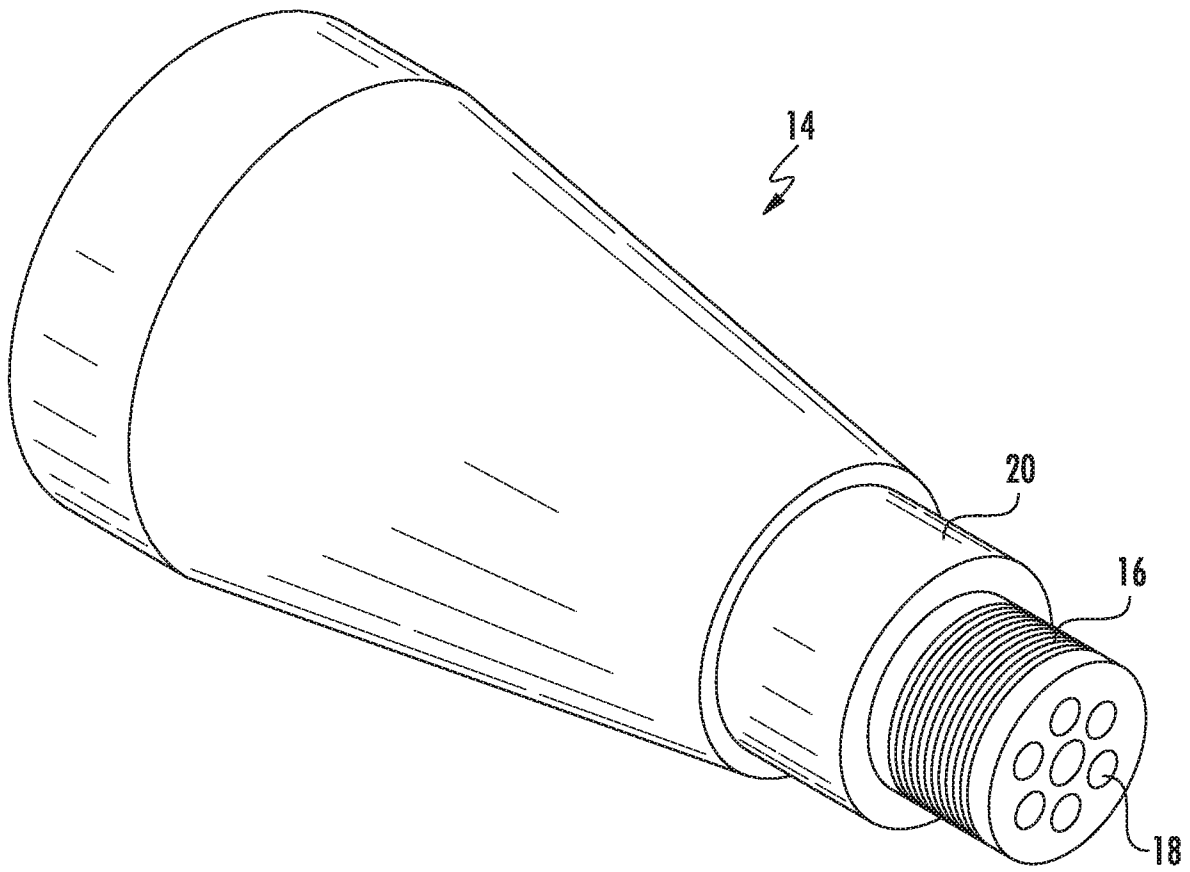

FIG. 2

3/8

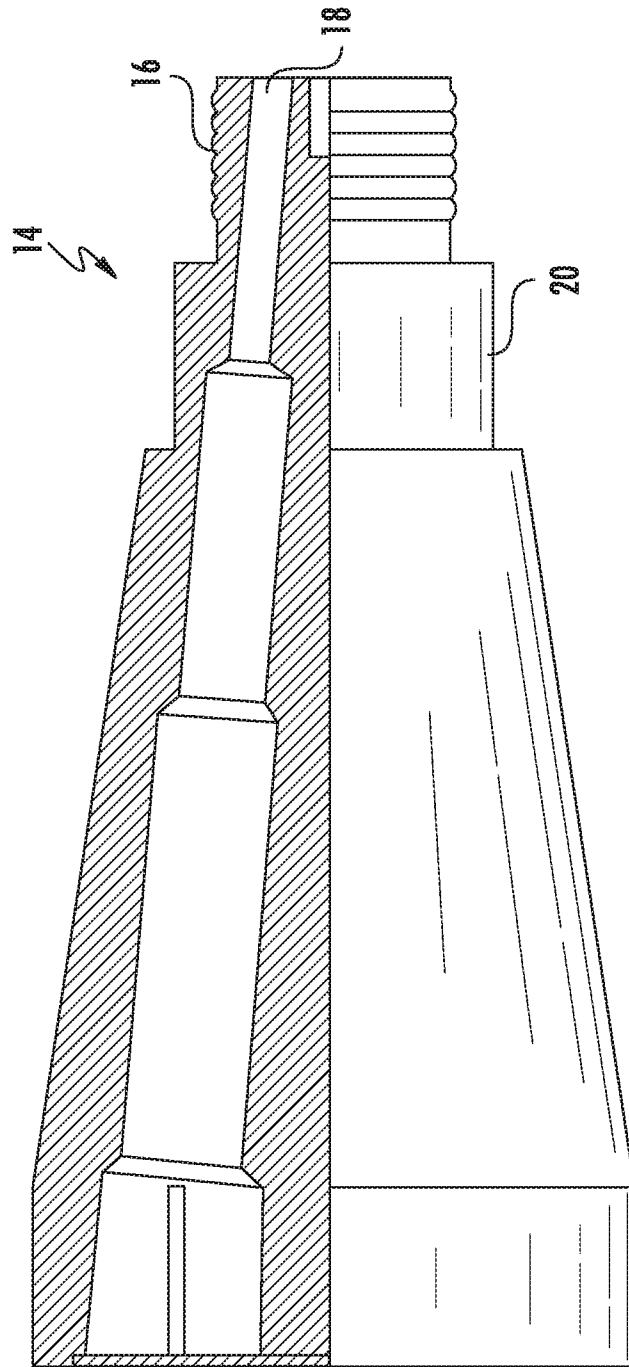

FIG. 3

4/8

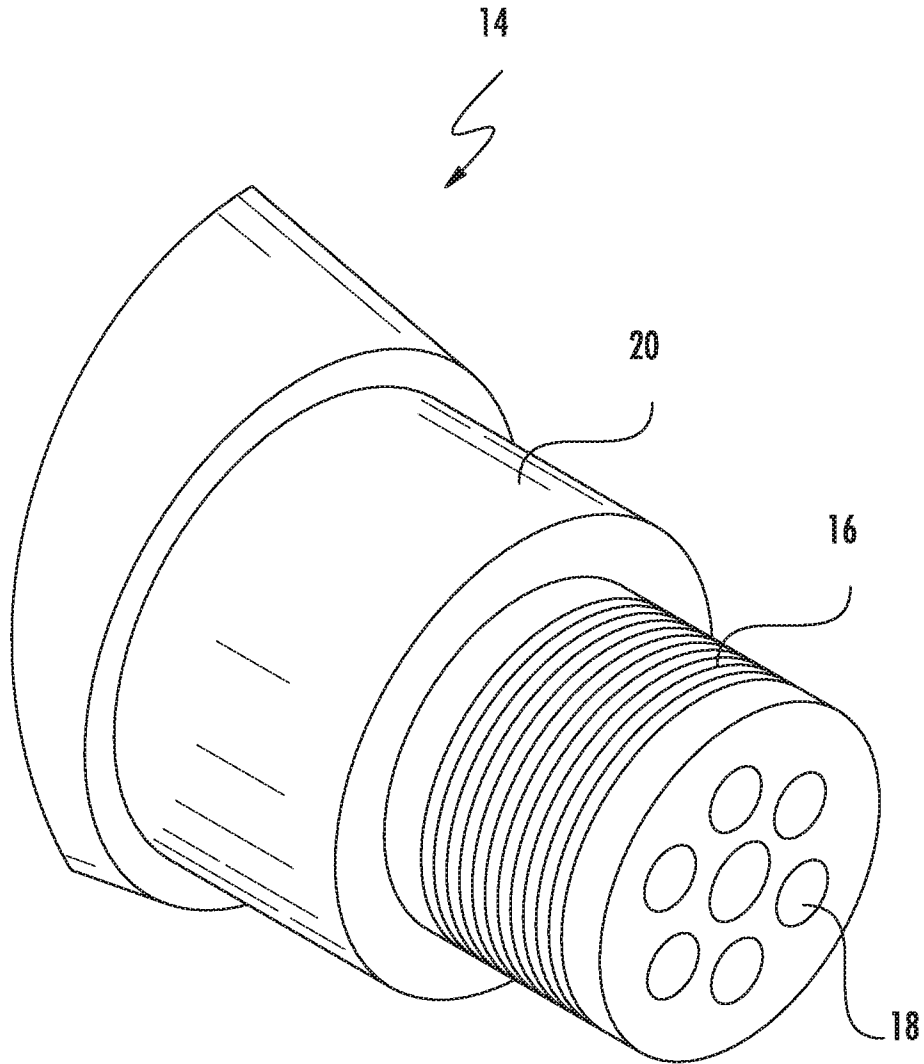

FIG. 4

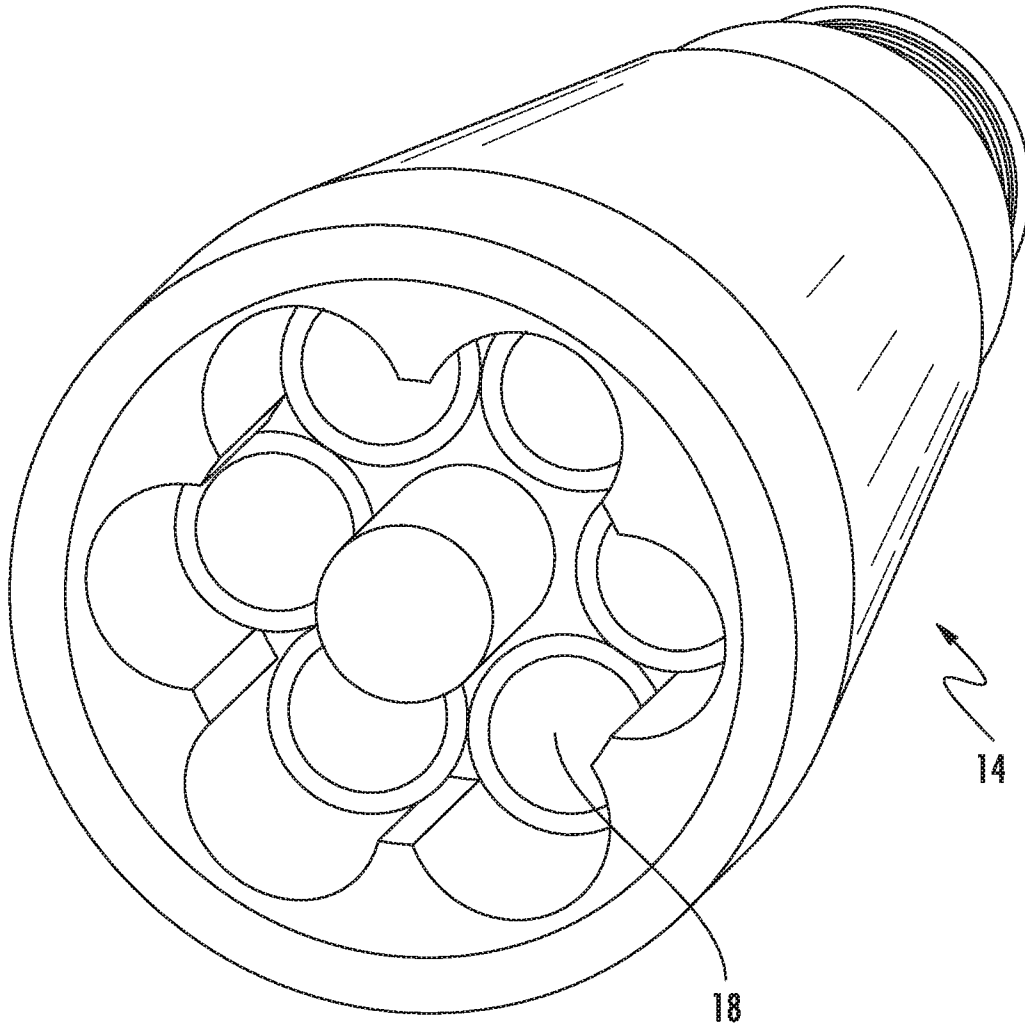

FIG. 5

6/8

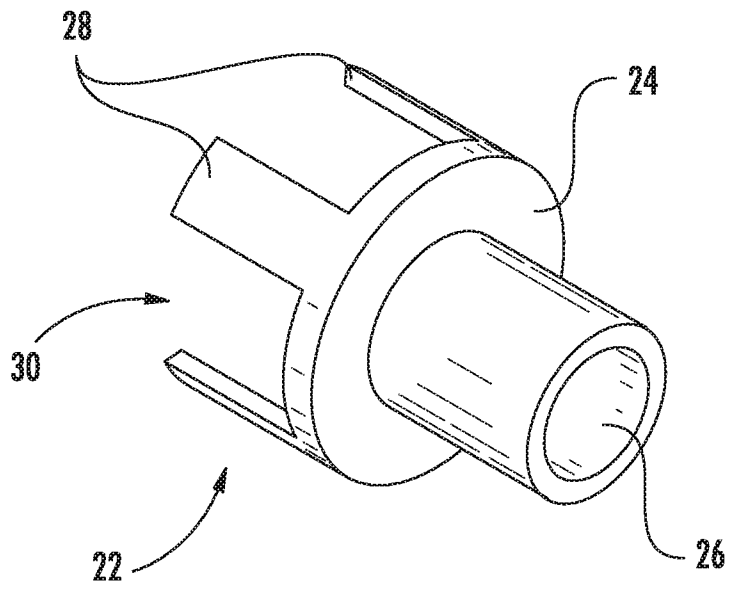

FIG. 6

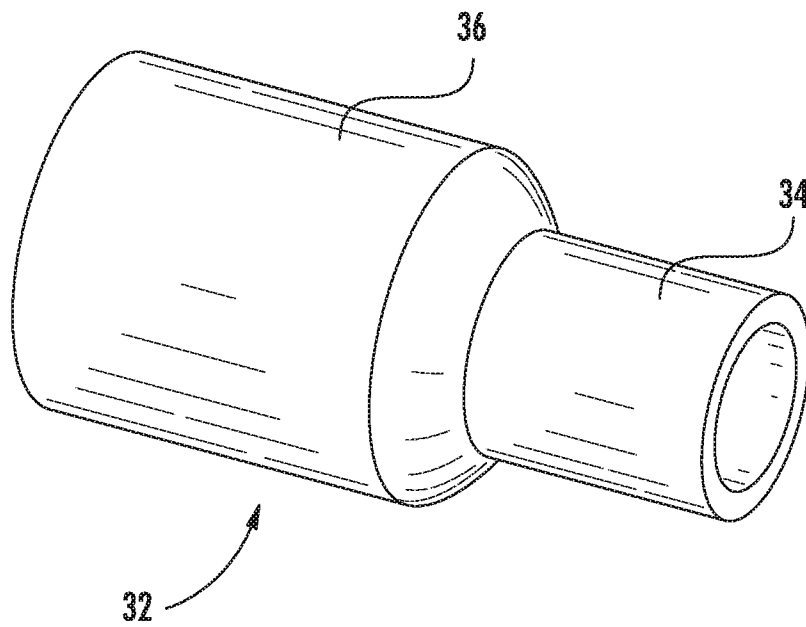

FIG. 7

7/8

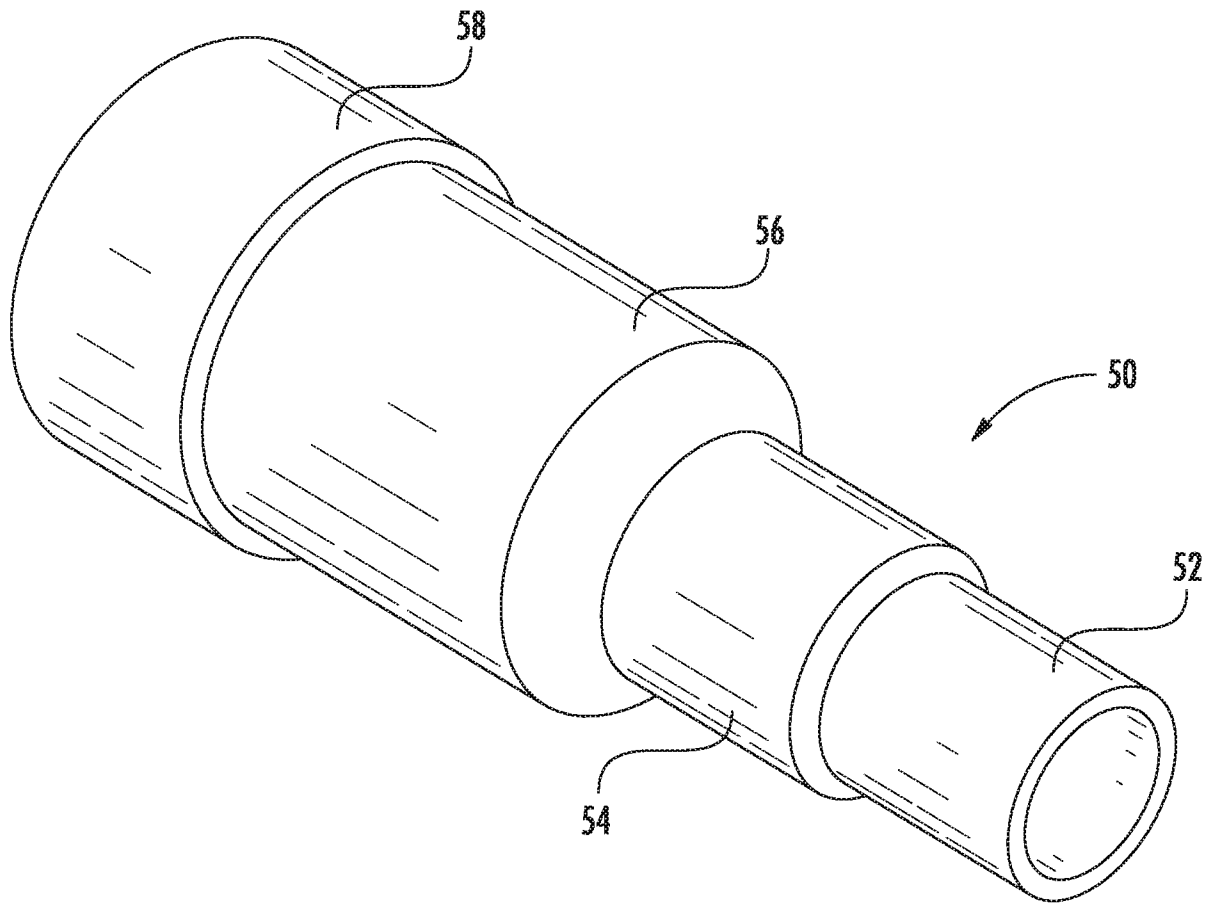
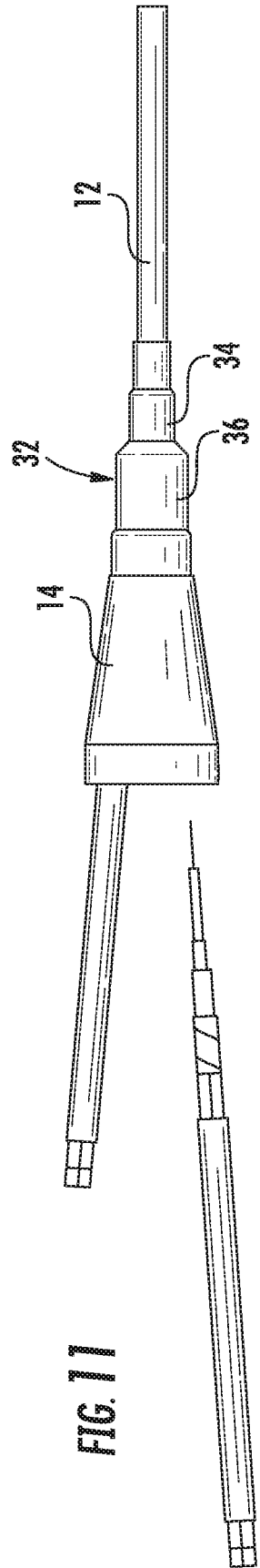
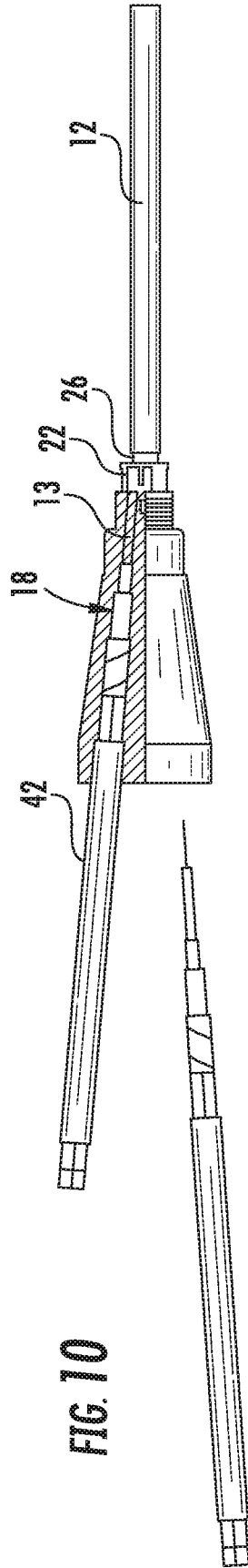
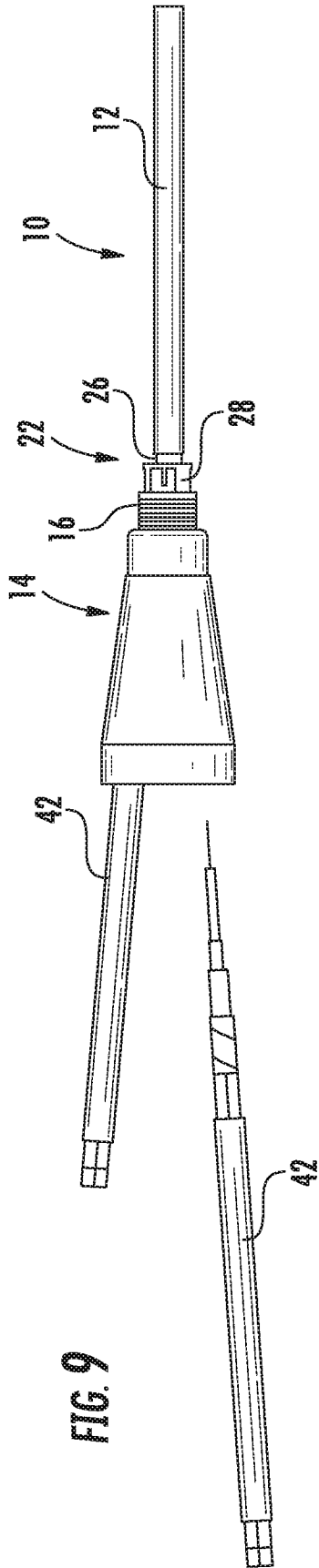

FIG. 8



INTERNATIONAL SEARCH REPORT

International application No.
PCT/US2017/022507**A. CLASSIFICATION OF SUBJECT MATTER**
H01B 11/18(2006.01)i, H01B 11/22(2006.01)i

According to International Patent Classification (IPC) or to both national classification and IPC

B. FIELDS SEARCHEDMinimum documentation searched (classification system followed by classification symbols)
H01B 11/18; H01R 4/10; H02G 15/02; G02B 6/00; G02B 6/36; G02E 6/44; H01B 11/22Documentation searched other than minimum documentation to the extent that such documents are included in the fields searched
Korean utility models and applications for utility models
Japanese utility models and applications for utility modelsElectronic data base consulted during the international search (name of data base and, where practicable, search terms used)
eKOMPASS(KIPO internal) & Keywords: cable, fiber, furcation, distribute, tube, hole**C. DOCUMENTS CONSIDERED TO BE RELEVANT**

Category*	Citation of document, with indication, where appropriate, of the relevant passages	Relevant to claim No.
X	US 2014-0140671 A1 (ANDREW LLC) 22 May 2014 See paragraphs [51]-[62], claim 10 and figures 1-21.	1,6-8,19
Y		2-5,11-16,20
A		9,10,17,18
Y	US 4707566 A (TITCOMBE et al.) 17 November 1987 See column 4, lines 1-31 and figures 1-3.	2,3,5,11-16,20
Y	US 2010-0104253 A1 (MOMOTSU et al.) 29 April 2010 See paragraphs [46]-[58], claim 1 and figures 1A-2.	4,13,14
A	US 2011-0091169 A1 (VAN DER MEULEN et al.) 21 April 2011 See paragraphs [54]-[65] and figure 1.	1-20
A	CN 202533632 U (HUIZHOU HUIJU ELECTRIC WIRE PRODUCT CO., LTD.) 14 November 2012 See claims 1-4 and figures 1,2.	1-20

 Further documents are listed in the continuation of Box C. See patent family annex.

* Special categories of cited documents:

"A" document defining the general state of the art which is not considered to be of particular relevance

"E" earlier application or patent but published on or after the international filing date

"L" document which may throw doubts on priority claim(s) or which is cited to establish the publication date of another citation or other special reason (as specified)

"O" document referring to an oral disclosure, use, exhibition or other means

"P" document published prior to the international filing date but later than the priority date claimed

"T" later document published after the international filing date or priority date and not in conflict with the application but cited to understand the principle or theory underlying the invention

"X" document of particular relevance; the claimed invention cannot be considered novel or cannot be considered to involve an inventive step when the document is taken alone

"Y" document of particular relevance; the claimed invention cannot be considered to involve an inventive step when the document is combined with one or more other such documents, such combination being obvious to a person skilled in the art

"&" document member of the same patent family

Date of the actual completion of the international search

31 May 2017 (31.05.2017)

Date of mailing of the international search report

31 May 2017 (31.05.2017)

Name and mailing address of the ISA/KR

International Application Division
Korean Intellectual Property Office
189 Cheongsa-ro, Seo-gu, Daejeon, 35208, Republic of Korea

Facsimile No. +82-42-481-8578

Authorized officer

KIM, Yeon Kyung

Telephone No. +82-42-481-3325



INTERNATIONAL SEARCH REPORT

Information on patent family members

International application No.

PCT/US2017/022507

Patent document cited in search report	Publication date	Patent family member(s)	Publication date
US 2014-0140671 A1	22/05/2014	CN 104350405 A	11/02/2015
		CN 104350405 B	25/05/2016
		CN 104797964 A	22/07/2015
		CN 104813211 A	29/07/2015
		CN 104871054 A	26/08/2015
		CN 104871054 B	26/10/2016
		CN 104919348 A	16/09/2015
		EP 2862015 A1	22/04/2015
		EP 2920625 A1	23/09/2015
		EP 2920627 A1	23/09/2015
		EP 2920627 A4	13/01/2016
		EP 2920631 A1	23/09/2015
		EP 2920632 A1	23/09/2015
		US 2013-0336622 A1	19/12/2013
		US 2014-0138151 A1	22/05/2014
		US 2014-0140664 A1	22/05/2014
		US 2014-0140669 A1	22/05/2014
		US 2015-0168657 A1	18/06/2015
		US 8948557 B2	03/02/2015
		US 9235021 B2	12/01/2016
		US 9530544 B2	27/12/2016
		US 9536640 B2	03/01/2017
		US 9618718 B2	11/04/2017
		WO 2013-188719 A1	19/12/2013
		WO 2014-077952 A1	22/05/2014
		WO 2014-077953 A1	22/05/2014
		WO 2014-077955 A1	22/05/2014
		WO 2014-077956 A1	22/05/2014
		WO 2016-126480 A1	11/08/2016
		US 4707566 A	17/11/1987
EP 0210062 A2	28/01/1987		
EP 0210062 B1	17/03/1993		
JP 62-022378 A	30/01/1987		
US 2010-0104253 A1	29/04/2010	JP 2010-102211 A	06/05/2010
		JP 4602447 B2	22/12/2010
		US 7894700 B2	22/02/2011
US 2011-0091169 A1	21/04/2011	CN 102057310 A	11/05/2011
		CN 102057310 B	19/11/2014
		EP 2294466 A1	16/03/2011
		JP 2011-523101 A	04/08/2011
		JP 5268124 B2	21/08/2013
		US 8571367 B2	29/10/2013
		WO 2009-150011 A1	17/12/2009
CN 202533632 U	14/11/2012	None	