

E. E. GAMON.
WATER METER.

APPLICATION FILED AUG. 12, 1909.

953,200.

Patented Mar. 29, 1910.

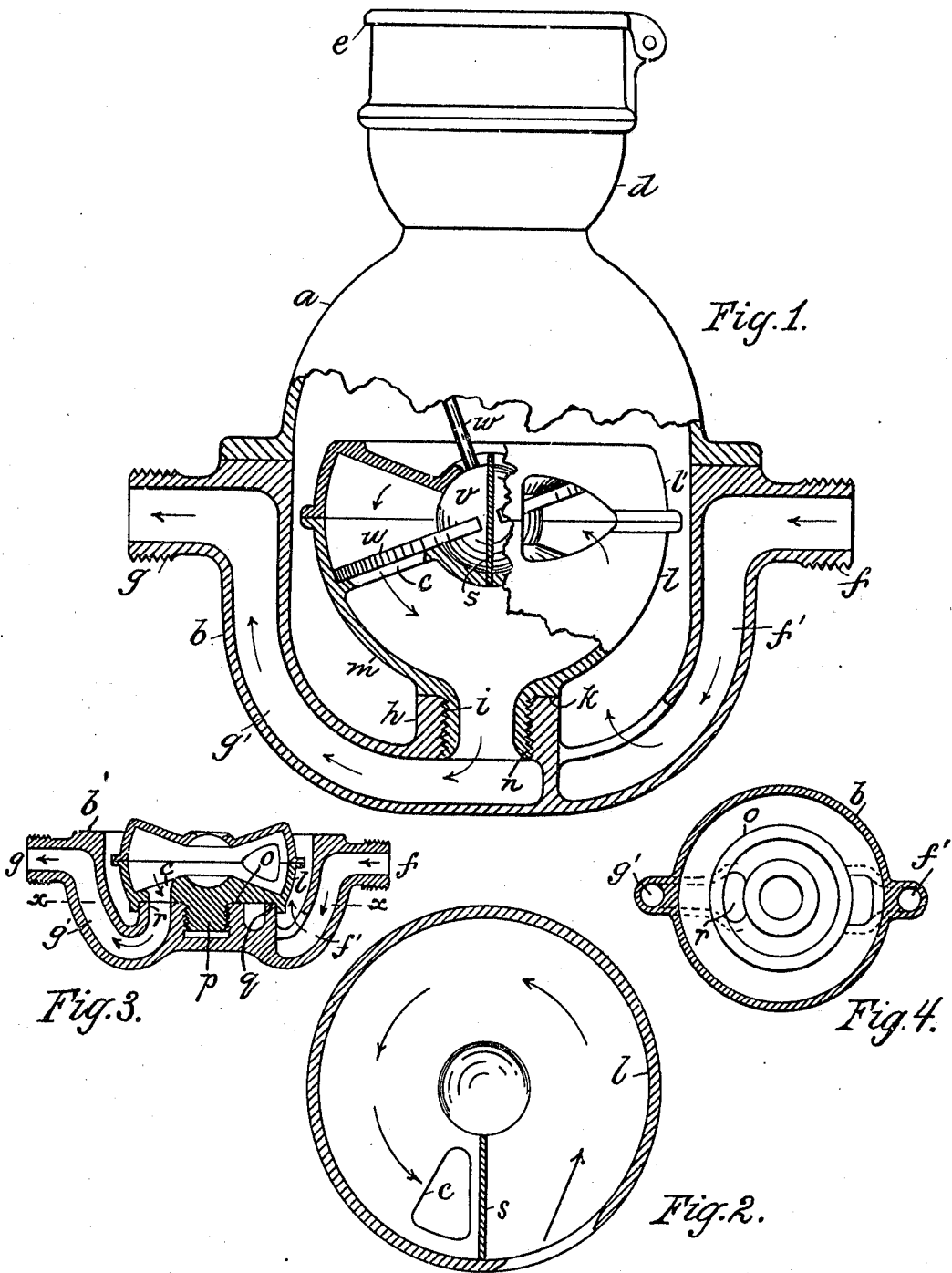

WITNESSES
C. A. Allison
A. R. Christie

INVENTOR
Ernest E. Gamon
BY
Frederick C. Fischer
ATTORNEY

UNITED STATES PATENT OFFICE.

ERNEST E. GAMON, OF NEWARK, NEW JERSEY.

WATER-METER.

953,200.

Specification of Letters Patent. Patented Mar. 29, 1910.

Application filed August 12, 1909. Serial No. 512,512.

To all whom it may concern:

Be it known that I, ERNEST E. GAMON, a citizen of the United States, residing in the city of Newark, county of Essex, and State of New Jersey, have invented certain new and useful Improvements in Water-Meters, of which the following is a full, clear, and exact description, such as will enable others skilled in the art to which it pertains to make and use the same.

My invention relates to water meters of the disk type, comprising an outer inclosing case, and an inner piston chamber in axial alinement with the inclosing case and circumferentially free therefrom, the disk chamber being provided with suitable inlet and outlet ports and containing the nutating piston or disk.

The principal feature of my present invention consists in providing an outlet port at the under side of the disk chamber to discharge downwardly and inside of the area of action of the disk, said outlet port registering with a corresponding port formed in the lower casing of the water meter communicating with the outlet spud.

In carrying out my invention, I make use of the accompanying drawings, in which—

Figure 1 shows a vertical elevation of my improved meter, the lower part being broken away and shown in section. Fig. 2 is a sectional plan view of the lower half of the disk chamber showing the location of the outlet. Fig. 3 is a modified form of my improved meter showing a vertical sectional elevation of the disk chamber mounted in the lower casting of the meter; and Fig. 4 shows a sectional plan view taken on lines $x-x$ of Fig. 3, of the lower inclosing case.

Similar letters of reference refer to like parts throughout the specification and drawings.

The inclosing case is composed of two shell-like castings a and b fastened together in any suitable manner. The upper casting a has the register inclosing compartment d cast or otherwise secured thereto and is provided with the usual cover e . The registering mechanism and gear train may be of the usual type in common use in meters, hence they are not here shown. The lower casting b is preferably hemispherical in shape and is provided with an inlet spud f and an outlet spud g integral therewith, the inlet spud f being continuous with the tubular channel f' extending downwardly as a rib

on the exterior of the inclosing case b , and opening into the interior of the inclosing case b near the bottom thereof as shown in Fig. 1. An annular boss h rises from the bottom of the casting b and is in direct communication with the outlet spud g through the tubular channel g' which extends rib-like along the exterior of the case b diametrically opposite to the inlet tube f' . The boss h is internally threaded at i and surfaced off to form the seat k upon which the disk chamber l and l' is secured by the depending stem m which is provided with the tubular threaded boss n , taking into the threads i of the boss h . The under face of the stem m is surfaced off to coact with the seat k to form a water tight joint.

In a water meter, the water is usually caused to flow through the chamber in a counter clock-wise direction, in which case the threads i may be made left-handed so that the frictional action of the flowing water in the disk chamber will tend to maintain a tight joint at k , although a right-handed thread will give satisfactory results.

It will be seen that the disk chamber l and l' is spaced away from the inclosing case, thereby forming a receiving chamber for the inflowing water from the spud f . The disk chamber is made up of two sections l and l' secured together in any suitable manner, and provided with inlet and outlet ports. The inlet port is similar to that in common use in meters of this type, and opens directly into the receiving chamber above mentioned, while the outlet port c is located in the underside of the disk chamber l and opens downwardly and inside of the area of action of the disk into the depending stem m , thereby permitting a freer egress of the water from the disk chamber to the outlet spud g through the tubular channel g' .

The disk chamber is provided with the usual nutating piston u having a ball bearing v and gear train actuating rod w , which being of usual construction, require no special description here.

In carrying out my invention, the disk chamber may be attached to the bottom of the inclosing case in various ways.

In Fig. 3 is shown a modification in which a larger annular boss o is employed to support the disk chamber which is provided with a depending screw-threaded lug p . The surfaces of the boss o and the under

side of the disk chamber are faced off to form the water tight seat at *g*. The annular boss *o* is internally threaded to receive the screw-threaded lug *p* depending from the under side of the disk chamber.

From an inspection of Figs. 3 and 4 of the drawings, it will be noticed that an outlet port *r* is provided for in the boss *o* of the inclosing case *b*, which registers with the outlet port *c* formed in the under side of the disk chamber *l*. It will also be noticed that this outlet port *c* is located in the conical surface of the disk chamber adjacent to the diaphragm *s* and so arranged to discharge downwardly and inside of the area of action of the disk through the outlet port *r* in the boss *o* of the inclosing case, as to permit of the freest egress of the water from the piston chamber to the outlet spud *g*.

The outlet port *c* of the disk chamber *l* communicates directly with the tubular channel which extends along the exterior of the case and communicates with the outlet spud. The inlet spud communicates with the receiving chamber formed between the disk chamber and the outer inclosing case as in the previously described construction.

The operation of my improved meter should be sufficiently clear from the description and an inspection of the drawings. The flow of the water may be traced by following the arrows from the inlet spud *f* through the tubular channel *f'* and up through the same to the receiving chamber, then about the disk chamber *l*, *l'*, then through the disk chamber and through the outlet port *c* down through the channel *g'* and out through the spud *g*.

In the foregoing specification, I have referred to a modification which may be adopted in practicing my invention, but I have not endeavored to specify all the modifications which might be employed, and I desire it to be distinctly understood that mention by me of this modification, is not in any way intended to exclude others not referred to, but which are within the spirit and scope of my invention.

I claim:

1. A water meter comprising an inclosing case, securing means in the bottom of said case provided with a discharge port, a disk chamber circumferentially free from said inclosing case, having inlet and discharge ports and provided with means coacting with said securing means for securing said chamber to said inclosing case, the discharge port arranged in said disk chamber to coact with the discharge port arranged in the securing means in said inclosing case.

2. A water meter comprising an inclosing case provided with inlet and outlet spuds, a boss integral with one of said spuds, a disk chamber provided with inlet and outlet ports located within said inclosing case and separated therefrom to form a receiving chamber, said outlet port registering with said boss and arranged to discharge downwardly and inside the area of action of the disk.

This specification signed and witnessed this 11th day of August, 1909.

ERNEST E. GAMON.

Witnesses:

FREDK. C. FISCHER,
C. A. ALLISTON.