

Feb. 14, 1933.

J. P. ANDERSON

1,897,831

CAR CONSTRUCTION

Filed Jan. 31, 1931

2 Sheets-Sheet 1

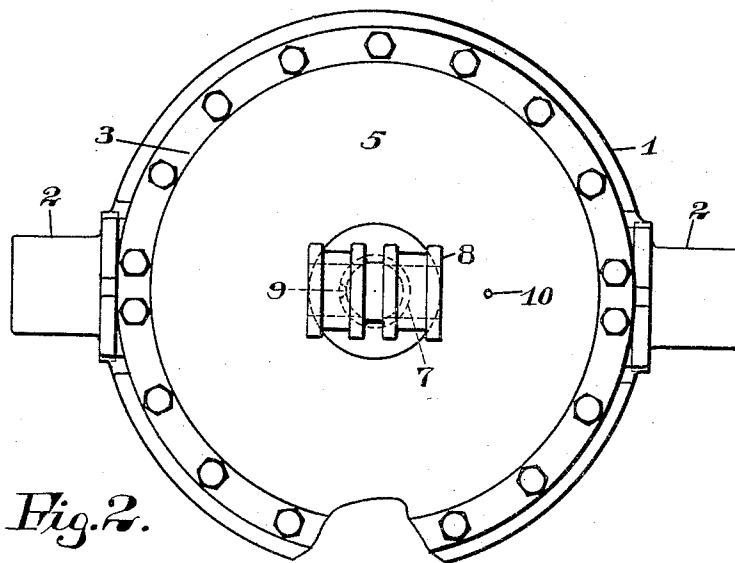

Fig. 2.

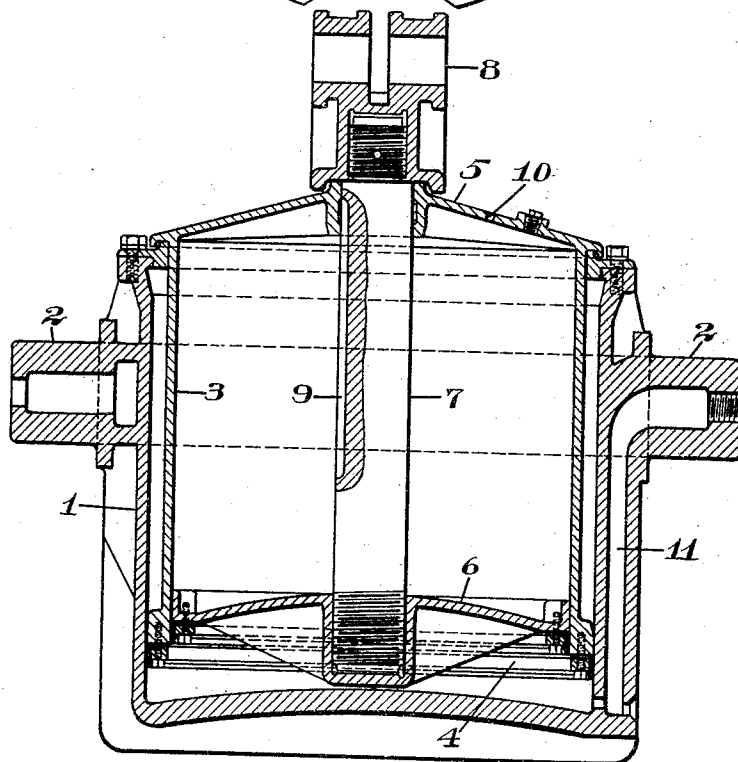

Fig. 1.

INVENTOR  
John P. Anderson  
BY *J. S. Tyler*  
his ATTORNEY

Feb. 14, 1933.

J. P. ANDERSON

1,897,831

CAR CONSTRUCTION

Filed Jan. 31, 1931

2 Sheets-Sheet 2

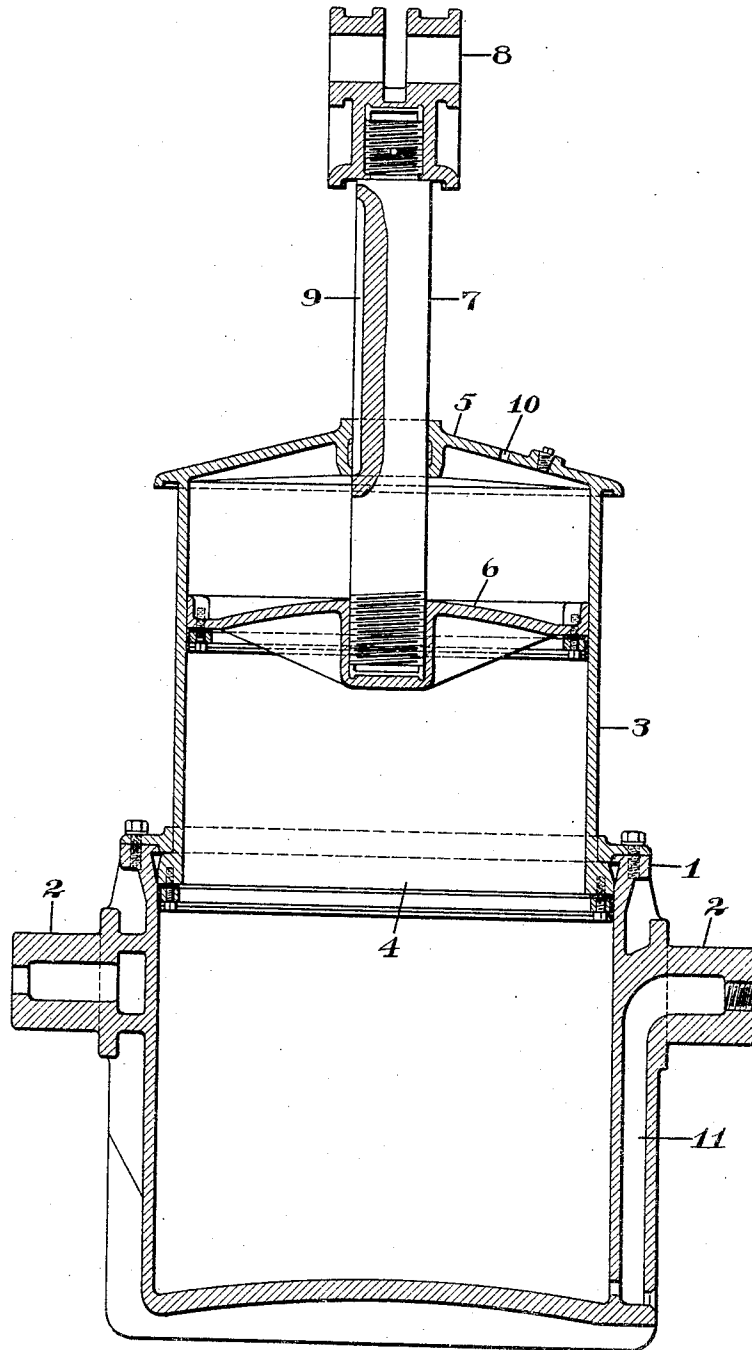

*Fig. 3.*

INVENTOR

*John P. Anderson*  
BY *J. H. Tyler*  
his ATTORNEY

# UNITED STATES PATENT OFFICE

JOHN P. ANDERSON, OF KOPPEL, PENNSYLVANIA, ASSIGNOR, BY MESNE ASSIGNMENTS,  
TO KOPPEL INDUSTRIAL CAR AND EQUIPMENT COMPANY, OF McKEES ROCKS, PENN-  
SYLVANIA, A CORPORATION OF PENNSYLVANIA

## CAR CONSTRUCTION

Application filed January 31, 1931. Serial No. 512,622.

An object of my invention is to provide a means for using the body tilting mechanism of a dump car for automatically absorbing the shocks of the final tilting movements of the body in discharging the lading.

Another object of my invention is to provide means for automatically varying the escape of the air trapped between the piston and the cylinder head as the body is being tilted.

In dump cars of large capacity as used at present, the body is supported on the underframe by pivotal means, either at the center or at each side of the underframe and a power actuated device is employed for tilting the body to discharge the lading. As the body is tilted, the accumulated weight of the lading and body in the center supported body and the shifting of the weight of lading in the side supported bodies causes the body to move abruptly to final tilted position with a resultant shock to the underframe and the body tilting mechanism. Various means have been provided to absorb these shocks which have in a measure protected the body and underframe from injury but have given little or no protection to the body tilting mechanism. By means of my invention I have provided the shock absorbing mechanism in the body tilting cylinders and utilized the air which is always present between the upper side of the piston and the top or head of the body tilting cylinder. In this manner I not only check the abrupt movement of the body to a final tilted position but also utilize the cushioning effect of this compressed trapped air to prevent injuries to the body tilting mechanism, without interfering with the operation of the body tilting mechanism.

Referring to the drawings, Fig. 1 is a transverse vertical section of the body tilting cylinder and contained piston; Fig. 2 is a plan view of Fig. 1; Fig. 3 is a view similar to Fig. 1 showing the piston advanced in the cylinder as the body nears the final tilted position. Since my invention may be utilized on either a center hinge or spaced trunnion supported body, I have not shown any of the details of the car or of

the body tilting mechanism, for any of the above types of cars which use fluid pressure means for actuating the body tilting cylinders. The cylinder shown in the drawings is of the type known as a telescoping cylinder and is preferably used with a trunnion supported body but it is to be understood that my invention can be used equally as well in an ordinary cylinder when the advantages of increased stroke are not required.

Referring now in detail to the drawings where like reference characters refer to like parts, reference character 1 indicates the outer cylinder which is adapted to be mounted on the car underframe by means of trunnion bearings 2 at the sides of the cylinder. Reference character 3 indicates the inner telescoping portion of the cylinder which is adapted for vertical movement within the outer cylinder 1 and has an open end 4 within the cylinder 1 and a closed head 5 at the opposite end. Mounted within the cylinder 3 is a piston 6 having a stem 7 projecting through the head 5 of the cylinder 3 and having a connection 8 for engagement with the body of the car. The stem 7 of the piston has a peripheral slot 9 which extends for a portion of the length of the stem and terminates short of the piston 6. The head 5 of the piston 3 has an opening 10 therein which has a cross sectional area less than the cross sectional area of the peripheral slot 9 of the stem 7.

The operation of the piston in tilting the body is as follows: Fluid pressure enters the lower end of the cylinder 1, preferably through openings 11 formed in the trunnions 2 and the resultant pressure on the underside of the piston 6 and inner cylinder 3 causes these members to rise, they in turn transmitting their motion to the car body which is moved from horizontal load-carrying position to tilted position for the discharging of the contained lading. By referring now to Fig. 3 of the drawings, it will be observed that as the piston moves upwardly within the cylinder 3, the upper end of the peripheral slot 9 in the stem of the piston projects outwardly beyond the upper end of the cylinder, connecting the

interior of the cylinder 3 with the outer atmosphere and permits the air which is trapped between the upper side of the piston and the head of the cylinder to exhaust quickly to the outer atmosphere until the upward movement of the piston stem carries the entire length of the slotted portion beyond the cylinder head. The air remaining between the piston and cylinder head is compressed by the advancing piston, thereby providing a pneumatic cushion for absorbing the shocks to the tilting mechanism and car body when the body moves more rapidly to fully tilted position as the amount of contained lading is reduced. However, as the fluid pressure continues to bear on the under side of the piston, the air trapped between the piston and cylinder head is permitted to escape around the opening in the cylinder head for the piston stem, so as to provide a slow exhaust of the air and permit the piston to move to a fully extended position.

It may be found that due to packing being used around the piston stem or from other causes, the connection between the cylinder head and piston stem is sufficiently tight to prevent the ready escape of the trapped air, and it may be found desirable to provide an additional opening in the head of the cylinder such as the opening 10 which is preferably of less cross sectional area than the cross sectional area of the peripheral slot 9 and which will permit the piston to move slowly to fully extended position.

From the above it will be observed that I have provided a means for a quick exhausting of the trapped air during the initial stages of the body tilting movement and thereafter provided a slower exhausting of the trapped air as the body moves to fully tilted position and thereby utilizes the trapped air as a cushion to absorb the shocks which would automatically be transmitted from the tilting body to the underframe and body tilting mechanism. The sizes of the peripheral slot 9 and opening 10 in the cylinder head may be varied to provide any rate of exhausting of the air which may be desirable and to obtain the desired cushioning effect.

Although I have shown only the preferred form of my invention, many modifications will be apparent to those skilled in the art which will come within the scope of my invention as providing a means for varying the escape of the trapped air within the cylinder to obtain the functions enumerated.

Having thus described the invention what I claim as new and desire to secure by Letters Patent is:

1. In a dump car a body tilting mechanism comprising a trunnioned outer cylinder, a movable inner cylinder, a piston mounted in said inner cylinder and having a stem projecting beyond the top of said inner

cylinder, a slot in the periphery of said stem for a portion of the length thereof and an additional opening in the head of said inner cylinder.

2. In a dump car having a fluid pressure actuated body tilting mechanism, in combination, a body tilting cylinder, a piston within said cylinder with the stem thereof projecting through an end wall of said cylinder, a peripheral slot in said stem for a portion of the length thereof and spaced from said piston.

3. In a dump car having a fluid pressure actuated body tilting mechanism in combination, a body tilting cylinder, a piston within said cylinder with the stem thereof projecting through an end wall of said cylinder, an opening in said end wall, said opening being of such size as to relieve the pressure between said end wall of the cylinder and the advancing piston but not sufficiently large to prevent compressing the air between the advancing piston and the head of the cylinder so that the compressed air acts as a shock-absorbing means between the end of the cylinder and the advancing piston.

4. In a dump car having a fluid pressure actuated body tilting mechanism in combination, a body tilting cylinder, a piston within said cylinder with the stem thereof projecting through an end wall of said cylinder, an opening in said end wall permitting a slow exhausting of the trapped air between the advancing piston and the end wall of said cylinder, said opening being of such size that the air between said end wall and advancing piston is compressed to provide a shock-absorbing means, means on said piston stem providing a quick exhausting of the trapped air for a portion of the length of the stroke of said piston.

JOHN P. ANDERSON.

110

115

120

125

130