

[54] **YARN CUTTER FOR CIRCULAR KNITTING MACHINES**

[76] Inventor: **Francesco Lonati**, via S. Polo 11, Brescia, Italy

[22] Filed: **Mar. 20, 1972**

[21] Appl. No.: **235,902**

[30] **Foreign Application Priority Data**

Apr. 8, 1971 Italy..... 22894/71

[52] **U.S. Cl.**..... 66/14, 66/134, 66/140 R, 66/145 R

[51] **Int. Cl.**..... **D04b 15/60**

[58] **Field of Search**..... 66/134, 145 R, 14, 140 R

[56] **References Cited**

UNITED STATES PATENTS

2,252,214	8/1941	St. Pierre.....	66/134
3,552,149	1/1971	Lonati.....	66/134 UX
778,164	12/1904	Barratt.....	66/140 R

2,245,205	6/1941	Lawson et al.....	66/134
2,304,916	12/1942	Hilker et al.....	66/134

Primary Examiner—Robert R. Mackey
Attorney, Agent, or Firm—Guido Modiano, Dr.; Albert Josif, Dr.

[57] **ABSTRACT**

A yarn cutter for circular knitting machines, particularly for yarn changers of double cylinder knitting machines, comprising at least one scissor member consisting of a striplike element mounted to slide backwards and forwards adjacent to a fixed blade. Pressed against the striplike element on the side opposite that adjacent the fixed blade, is a body of elastically yieldable material such as plastic material. This body occupies at least part of the width of the striplike element for the retention therebetween of the yarn or yarns after the cutting thereof. Means are also provided for adjusting the pressure of the elastic body on the striplike element.

1 Claim, 5 Drawing Figures

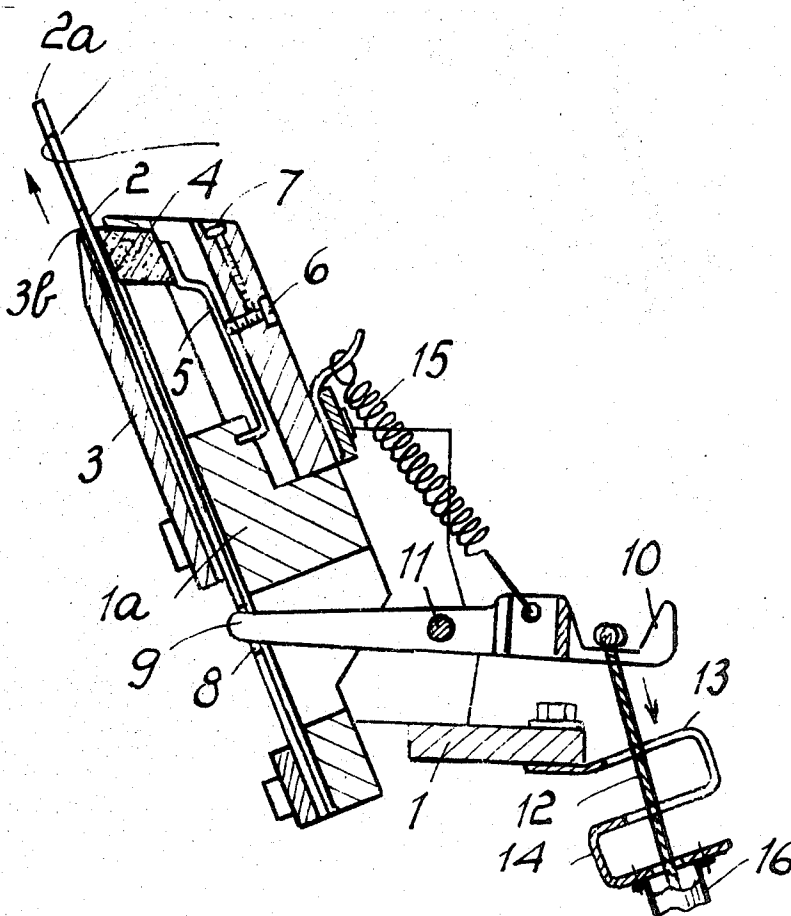

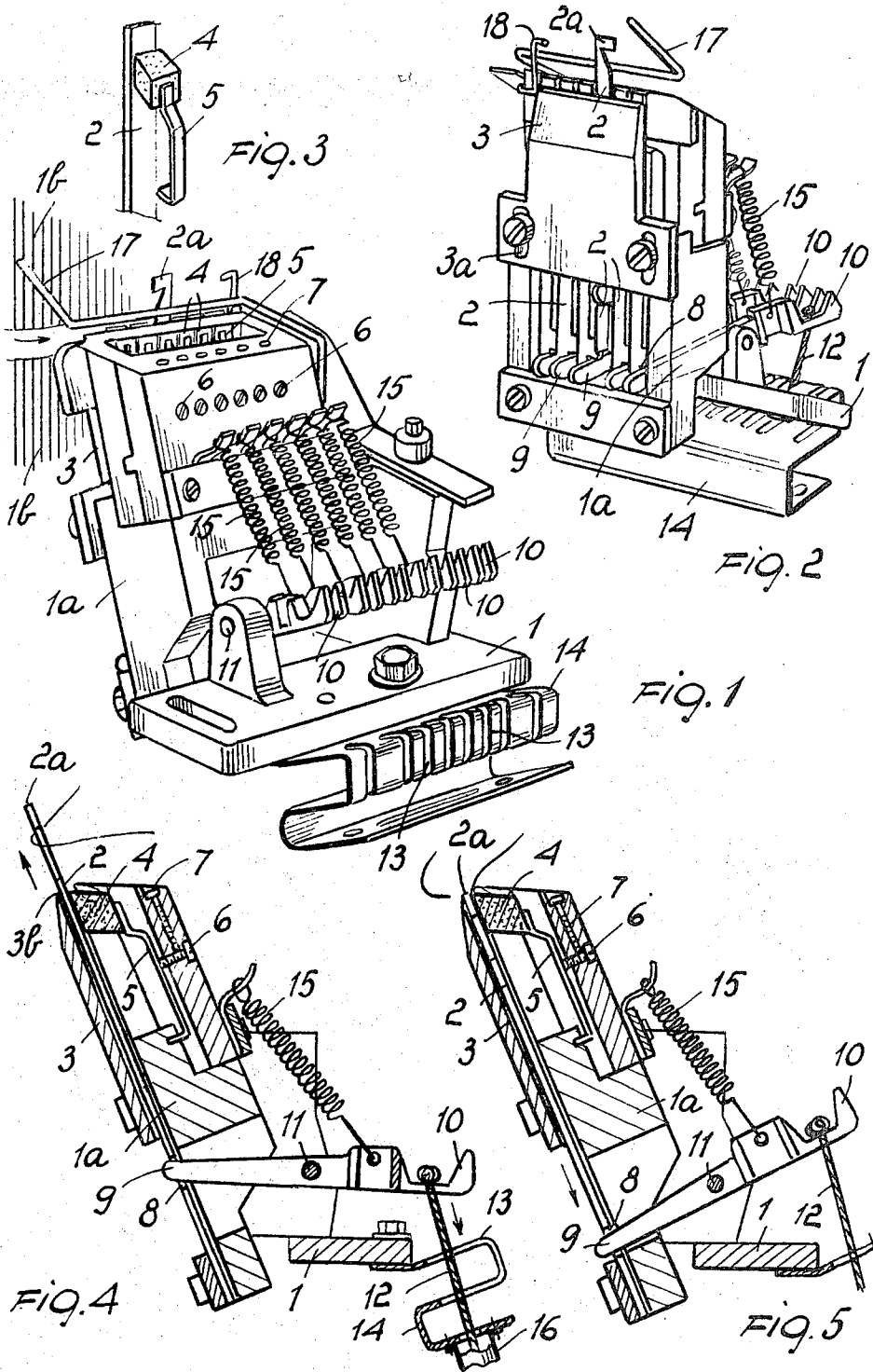

YARN CUTTER FOR CIRCULAR KNITTING MACHINES

BACKGROUND OF THE INVENTION

The present invention relates to a yarn cutter for circular knitting machines, particularly adapted for attachment to yarn changers of double cylinder knitting machines.

When a stocking is being knitted on a circular knitting machine of the double cylinder type, it may be required to replace the yarn used in the manufacture with another of a different type, different count or different color, and this is done by changing the yarn carrier by means of yarn changers which are fed with different yarns.

When a yarn carrier is disconnected from the manufacturing process, it is brought into the rest position and simultaneously the yarn stretched between the last needle which has taken said yarn and the corresponding yarn carrier is cut by a yarn cutter comprising a mobile driven metal blade which after cutting the yarn in co-operation with a metal counter blade, retains it.

In yarn cutters of known type certain disadvantages arise, among which is that of a not always effective retention of the various yarns, because of the fact that the retention adjustment is made for average values and is not satisfactory for retaining yarns of the smallest count.

The aforementioned disadvantage is accentuated in the case of knitting with two yarns of different type (or different count) used simultaneously, such as in the case of knitting so called plated knitwear.

In fact, the simultaneous retention of two yarns with a single scissor, such as happens in known yarn cutters, is very precarious because the yarn of smaller cross section tends to escape as the retention foil is raised by the larger yarn.

Consequently with yarn cutters of known type manufacturing defects frequently arise because of insufficient retention of the yarns during changes.

SUMMARY OF THE INVENTION

An object of the present invention is to largely obviate the aforementioned disadvantages relative to known devices, by providing a yarn cutter of rational conception, excellent operation and easy adjustment, by means of which the retention of yarns of different type or count, either single or combined, is assured. Another important object of the invention is to provide a yarn cutter in which the necessary periodical sharpening operations are simplified.

Another object of the invention is to provide a yarn cutter of easy construction and low cost.

These and further objects are attained by the yarn cutter for circular knitting machines, according to the invention, comprising at least one scissor member consisting of a striplike element mounted to slide backwards and forwards in the direction of its own length adjacent to a fixed blade and characterized in that a body of elastically yieldable material such as plastic material or the like is disposed pressed to said striplike element on the side opposite that adjacent to said fixed blade, and occupying at least part of the width of said striplike element, for the retention between this latter and said body of the yarn or yarns immediately after their cutting, means being provided for adjusting the pressure of said body on said striplike element.

BRIEF DESCRIPTION OF THE DRAWING

Further characteristics and advantages of the invention will be more evident from the detailed description of a preferred but not exclusive embodiment of a yarn cutter, according to the invention, illustrated by way of example in the accompanying drawing in which:

FIGS. 1 and 2 are perspective views of the yarn cutter according to the invention, seen from two opposite sides respectively;

FIG. 3 is a perspective view of a detail of the same device;

FIG. 4 is a vertical section through the device with a scissor member in the open position;

FIG. 5 is a vertical section through the device with all scissor members in the closed position.

DESCRIPTION OF THE PREFERRED EMBODIMENT

With reference to said figures, the yarn cutter according to the invention (by the term "yarn cutter" is meant a device which in addition to cutting also provides for retaining the yarns as the changes are made) comprises a support structure 1 which extends upwards in the form of a plate 1a which is fixed in an inclined position near the two cylinders 1b (FIG. 1) of the knitting machine and near a yarn changer (not shown) provided to the left of said yarn cutter, with reference to FIG. 1.

Various scissor members (six in the example shown) are associated with the plate body 1a, each of them comprising a striplike element 2 mounted to slide backwards and forwards in the direction of its own length and terminating upwards with a hook portion 2a.

The striplike elements 2 are mounted parallel one to the other in corresponding guide grooves and are adjacent to a stationary plate element defining a single blade 3 fixed to the internal side of the plate body 1a by means of screws which pass through slots 3a which allow the height of the blade to be adjusted. The cutting edge 3b of the blade is to the top, slightly below the extremities of the hook portions 2a of the striplike elements 2 when these are in the rest position. By this arrangement, the cutting edge 3b of the blade 3 cuts the yarns after they have been hooked by the hook portions 2a and pulled down by them.

At each striplike element 2 a yarn retaining block 4 of elastically yieldable material is provided, preferably of the material commonly known as "nylon" or a like material, said block being pressed towards the striplike element 2 by a corresponding flat metal spring 5 embedded at its lower end into the plate body 1a, its elastic force being adjustable by means of a screw 6 which, after adjustment, is locked by another screw 7 disposed perpendicularly to screw 6. In the example shown six blocks 4 are provided disposed one beside the other in a quadrangular space formed at the top of the plate body 1a.

For moving the striplike elements 2 backwards and forwards, each of them is provided with a recess 8 into which the projecting end 9 of a lever 10 pivoted at 11 to the fixed structure 1 engages. Each lever 10 is moved by a Bowden wire whose cable is fixed to the lever and passes through slots 13 in a shaped plate member 14 rigid with the fixed part 1, and its corresponding sheath 16 is fixed to said plate member 14. The levers 10 are moved against the reaction of corresponding springs 15

which tend to keep the extremities 9 of said levers 10 lowered so that normally the striplike elements 2 are disposed in the lowered position with their hook portions 2a close to the sharpened edge 3b of the blade 3.

At the top of the plate member 1a there is a wire-like member 17 of arched shape, disposed transversely and projecting for guiding the yarns during the stage immediately preceding their cutting. Close to said wire-like member 17 there is a further wire-like member 18 which stops the machine should the yarn not be cut. In fact, the yarn which has not been cut is taken by the hook portion of member 18 and resiliently displaces this member 18 which acts on a microswitch (not shown) which stops current supply to the machine.

The yarn cutter according to the invention operates in the following manner.

The device comes into operation when yarns are to be changed, i.e., when the yarn carriers (not shown) of the yarn changer move, by known mechanisms, from a rest position to a working position and vice versa, so as to feed certain yarns to the knitting machine and exclude others.

When a yarn carrier is moved into the rest position, i.e. when the corresponding yarn is withdrawn from the needle cylinders, said yarn must be cut and retained in such a manner as to be ready for re-entry into the machine. This is done by raising the desired striplike element 2 by pulling a cable 12 immediately before the movement of the yarn carrier, said element 2 again assuming for example the position shown in FIGS. 1, 2 and 4.

When the yarn is removed from the machine, it passes between the wire-like member 17 and the plate body 1, being thus guided against the portion 2a of the previously raised striplike element 2. Immediately afterwards the striplike element 2 is driven downwards by the action of the corresponding spring 15, after the cable 12 has been released. As the hook portion 2a is lowered, the yarn is cut by the cutting edge 3b of the blade 3, and the same yarn is retained by pressure between the portion 2a and the corresponding nylon block 4. The arrangement shown in FIG. 5 is thus attained, in which the yarn has been cut and is retained between the hook portion 2a and the block 4 until the yarn is reinserted into the machine.

A very efficient retention action is set up on the yarn by its location between a metal member (2) and a member of yieldable plastic material (4), as excellent adherence is obtained due to a partial deformation of the block 4.

The disposition according to the invention is particularly advantageous when two yarns of different type or different count have to be cut and retained simultaneously. In this case the partial deformability of the block 4 of plastic material assures the simultaneous retention of two or even more yarns, independently of their characteristics. Thus, for example, if two yarns of different count are used, the yarn of smaller diameter does not escape as frequently happens with traditional devices, because the elasticity of the material which

constitutes the blocks 4 assures excellent adaptability and adherence even in the case of very different yarn diameters.

A further advantage of the device according to the invention is the possibility of adjusting the pressure of each block 4 on its corresponding striplike element 2 independently of the other blocks, by adjusting the screws 6. In this manner different pressures can be set up according to the various characteristics of the yarn to be retained at one or another of the scissor members.

The screws 7 lock the screws 6 after their adjustment so as to prevent any loosening due to vibrations during use. The wire-like member 18 serves for automatically stopping the machine (by closing a contact which inserts a relay) should the yarn not be cut because the hook portions 2a do not rise, or for other reasons. The thread cutter according to the invention is easily sharpened by a single operation on the edge 3b of the blade 3, which can be carried out after disassembling it.

It can be seen that the yarn cutter according to the invention is of reliable operation, and eliminates the danger of the yarns escaping on changing, with consequent reduction in the quantity of manufactured articles which have to be rejected. As stated, the device according to the invention is particularly advantageous for the production of plated knitwear.

The device according to the invention is applicable to all circular knitting machines, of one or two cylinders and one or more feeds.

The invention so conceived is susceptible to numerous modifications all of which fall within the scope of the inventive idea.

I claim:

1. A yarn cutting and retaining device for circular knitting machines, particularly double cylinder knitting machines, comprising in combination a fixed support structure arranged adjacent the needle cylinders, a plurality of elongated strip-like elements arranged adjacent to each other and each having a hooked end for taking a yarn, said strip-like elements being slidable inside said support structure along their own length and defining a plurality of movable cutting blades, a stationary plate element arranged contacting all of said strip-like elements at one face thereof and having a sharpened edge extending transverse to said strip-like elements for defining therewith a plurality of independently operating cutting units, a plurality of yarn retaining blocks of yieldable plastic material each associated to one of said strip-like elements at the face thereof opposite to said stationary plate element, said retaining blocks having a width provided for simultaneously retaining more than one yarn, spring means each having one end engaging one of said yarn retaining blocks for pressing it against the corresponding strip-like element, adjusting screws arranged within said support structure and acting on said spring means for adjusting the elastic force thereof against said yarn retaining blocks and means for selectively actuating said strip-like elements for cutting, retaining and releasing said yarns.

* * * * *